

1Gbps至2.7Gbps SFF/SFP激光器驱动器， 带有消光比控制

概述

MAX3738为+3.3V激光驱动器，专为数据速率从1Gbps至2.7Gbps的多速率收发模块而设计。激光器直流耦合到MAX3738，减少了外部元件数量，易于多速率运行。

激光器消光比控制(ERC)包括自动功率控制(APC)、调制补偿和片内温度补偿等。APC环路保持平均光功率恒定；调制补偿根据偏置电流调节调制电流。这些控制环路具有温度补偿，在整个温度范围和有效使用期限内保持恒定的消光比。

MAX3738接受差分数据输入信号。5mA至60mA(交流耦合时高达85mA)的宽调制电流范围和高达100mA的偏置电流范围，使MAX3738尤其适合于驱动光模块中的FP/DFB激光器。外部电阻设置所需的激光器电流值。MAX3738提供发送禁止控制(TX_DISABLE)、单点故障容限、偏置电流监视及光电流监视。该器件还提供一个锁定的失效输出(TX_FAULT)，用于指示故障，例如APC回路无法保持期望的平均光功率时。MAX3738符合SFF-8472发送器诊断及SFP MSA的定时要求。

MAX3738提供24引脚、4mm x 4mm薄型QFN封装，工作在-40°C至+85°C的扩展级温度范围内。

应用

多速率OC-3至OC-48 FEC收发器

千兆位以太网SFF/SFP和GBIC收发器

1Gbps/2Gbps光纤通道SFF/SFP和GBIC收发器

特性

- ◆ +3.3V单电源供电
- ◆ 47mA电源电流
- ◆ 85mA调制电流
- ◆ 100mA偏置电流
- ◆ 自动功率控制(APC)
- ◆ 调制补偿
- ◆ 片内温度补偿
- ◆ 用于交流耦合的自偏置输入
- ◆ 以地为参考的电流监测
- ◆ 激光器关断和报警输出
- ◆ 使能控制和激光器安全特性

订购信息

PART	TEMP RANGE	PIN-PACKAGE	PKG CODE
MAX3738ETG	-40°C to 85°C	24 Thin QFN	T2444-1

典型应用电路参见数据资料的末尾部分。

引脚配置

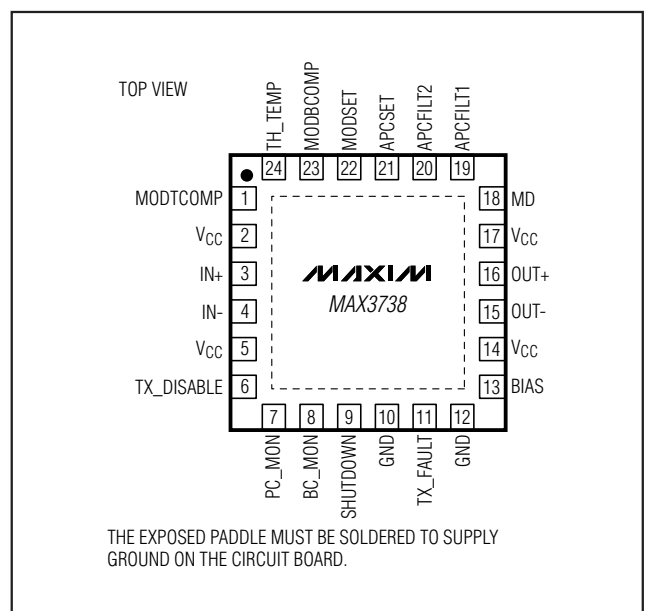

1Gbps至2.7Gbps SFF/SFP激光器驱动器， 带有消光比控制

ABSOLUTE MAXIMUM RATINGS

Supply Voltage V_{CC}-0.5V to +6.0V	OUT+, OUT-, BIAS Current.....-20mA to +150mA
IN+, IN-, TX_DISABLE, TX_FAULT, SHUTDOWN, BC_MON, PC_MON, APCFLT1, APCFLT2, MD, TH_TEMP, MODTCOMP, MODBCOMP, MODSET, and APCSET Voltage.....-0.5V to ($V_{CC} + 0.5V$)	Continuous Power Dissipation ($T_A = +85^\circ\text{C}$) 24-Pin TQFN (derate 20.8mW/ $^\circ\text{C}$ above +85 $^\circ\text{C}$)1805mW
	Operating Junction Temperature Range.....-55 $^\circ\text{C}$ to +150 $^\circ\text{C}$
	Storage Temperature Range.....-55 $^\circ\text{C}$ to +150 $^\circ\text{C}$

Stresses beyond those listed under "Absolute Maximum Ratings" may cause permanent damage to the device. These are stress ratings only, and functional operation of the device at these or any other conditions beyond those indicated in the operational sections of the specifications is not implied. Exposure to absolute maximum rating conditions for extended periods may affect device reliability.

ELECTRICAL CHARACTERISTICS

($V_{CC} = +2.97V$ to $+3.63V$, $T_A = -40^\circ\text{C}$ to $+85^\circ\text{C}$. Typical values are at $V_{CC} = +3.3V$, $I_{BIAS} = 60\text{mA}$, $I_{MOD} = 60\text{mA}$, $T_A = +25^\circ\text{C}$, unless otherwise noted.) (Notes 1, 2)

PARAMETER	SYMBOL	CONDITIONS		MIN	TYP	MAX	UNITS
POWER SUPPLY							
Supply Current	I_{CC}	(Note 3)			47	60	mA
Power-Supply Noise Rejection	PSNR	$f \leq 1\text{MHz}$, 100mAp-p (Note 4)			33		dB
I/O SPECIFICATIONS							
Differential Input Swing	V_{ID}	DC-coupled, Figure 1		0.2		2.4	Vp-p
Common-Mode Input	V_{CM}			1.7		$V_{CC} - V_{ID}/4$	V
LASER BIAS							
Bias-Current-Setting Range				1		100	mA
Bias Off Current		TX_DISABLE = high				0.1	mA
Bias-Current Monitor Ratio		I_{BIAS} / I_{BC_MON}		68	79	95	mA/mA
LASER MODULATION							
Modulation Current-Setting Range	I_{MOD}	(Note 5)		5		85	mA
Output Edge Speed		20% to 80% (Notes 6, 7)	$5\text{mA} \leq I_{MOD} \leq 85\text{mA}$		65	80	ps
Output Overshoot/Undershoot		With 1pF between OUT+ and OUT-			± 6		%
Random Jitter		(Notes 6, 7)			0.62	1.3	psRMS
Deterministic Jitter (Notes 6, 8)		2.7Gbps, $5\text{mA} \leq I_{MOD} \leq 85\text{mA}$			18	40	pSP-P
		1.25Gbps, $5\text{mA} \leq I_{MOD} \leq 85\text{mA}$			20	41	
Modulation-Current Temperature Stability		(Note 6)	$5\text{mA} \leq I_{MOD} \leq 10\text{mA}$		± 175	± 600	ppm/ $^\circ\text{C}$
			$10\text{mA} \leq I_{MOD} \leq 85\text{mA}$		± 125	± 480	
Modulation-Current-Setting Error		15 Ω load, $T_A = +25^\circ\text{C}$	$5\text{mA} \leq I_{MOD} \leq 10\text{mA}$			± 20	%
			$10\text{mA} < I_{MOD} \leq 85\text{mA}$			± 15	
Modulation Off Current		TX_DISABLE = high				0.1	mA
AUTOMATIC POWER AND EXTINCTION RATIO CONTROLS							
Monitor-Diode Input Current Range	I_{MD}	Average current into the MD pin		18		1500	μA
MD Pin Voltage						1.4	V
MD Current Monitor Ratio		I_{MD} / I_{PC_MON}		0.85	0.93	1.15	mA/mA

1Gbps至2.7Gbps SFF/SFP激光器驱动器， 带有消光比控制

MAX3738

ELECTRICAL CHARACTERISTICS (continued)

($V_{CC} = +2.97V$ to $+3.63V$, $T_A = -40^{\circ}C$ to $+85^{\circ}C$. Typical values are at $V_{CC} = +3.3V$, $I_{BIAS} = 60mA$, $I_{MOD} = 60mA$, $T_A = +25^{\circ}C$, unless otherwise noted.) (Notes 1, 2)

PARAMETER	SYMBOL	CONDITIONS	MIN	TYP	MAX	UNITS
APC Loop Time Constant		$C_{APC_FILT} = 0.01\mu F$, $\Delta I_{MD} / \Delta I_{BIAS} = 1/70$		3.3		μs
APC Setting Stability		(Note 6)		± 100	± 480	ppm/ $^{\circ}C$
APC Setting Accuracy		$T_A = +25^{\circ}C$			± 15	%
I_{MOD} Compensation-Setting Range by Bias	K	$K = \Delta I_{MOD} / \Delta I_{BIAS}$	0		1.5	mA/mA
I_{MOD} Compensation-Setting Range by Temperature	TC	$TC = \Delta I_{MOD} / \Delta T$ (Note 6)	0		1.0	mA/ $^{\circ}C$
Threshold-Setting Range for Temperature Compensation	T_{TH}	(Note 6)	+10		+60	$^{\circ}C$
LASER SAFETY AND CONTROL						
Bias and Modulation Turn-Off Delay		$C_{APC_FILT} = 0.01\mu F$, $\Delta I_{MD} / \Delta I_{BIAS} = 1/80$ (Note 6)			5	μs
Bias and Modulation Turn-On Delay		$C_{APC_FILT} = 0.01\mu F$, $\Delta I_{MD} / \Delta I_{BIAS} = 1/80$ (Note 6)			600	μs
Threshold Voltage at Monitor Pins	V_{REF}	Figure 5	1.14	1.3	1.39	V
INTERFACE SIGNALS						
TX_DISABLE Input High	V_{HI}		2.0			V
TX_DISABLE Input Low	V_{LO}	$R_{PULL} = 45k\Omega$ (typ)			0.8	V
TX_DISABLE Input Current		$V_{HI} = V_{CC}$			15	μA
		$V_{LO} = GND$		-70	-140	
TX_FAULT Output Low		Sinking 1mA, open collector			0.4	V
Shutdown Output High		Sourcing 100 μA	$V_{CC} - 0.4$			V
Shutdown Output Low		Sinking 100 μA			0.4	V

Note 1: AC characterization is performed using the circuit in Figure 2 using a PRBS $2^{23} - 1$ or equivalent pattern.

Note 2: Specifications at $-40^{\circ}C$ are guaranteed by design and characterization.

Note 3: Excluding I_{BIAS} and I_{MOD} . Input data is AC-coupled. TX_FAULT open, SHUTDOWN open.

Note 4: Power-supply noise rejection (PSNR) = $20\log_{10}(V_{noise} (on V_{CC}) / \Delta V_{OUT})$. V_{OUT} is the voltage across the 15 Ω load when I_{N+} is high.

Note 5: The minimum required voltage at the OUT+ and OUT- pins is +0.75V.

Note 6: Guaranteed by design and characterization.

Note 7: Tested with 00001111 pattern at 2.7Gbps.

Note 8: DJ includes pulse-width distortion (PWD).

1Gbps 至 2.7Gbps SFF/SFP 激光器驱动器， 带有消光比控制

典型工作特性

($V_{CC} = +3.3V$, $C_{APC} = 0.01\mu F$, $I_{BIAS} = 20mA$, $I_{MOD} = 30mA$, $T_A = +25^\circ C$, unless otherwise noted.)

**OPTICAL EYE DIAGRAM
(2.7Gbps, 2⁷ - 1 PRBS, 2.3GHz FILTER)**

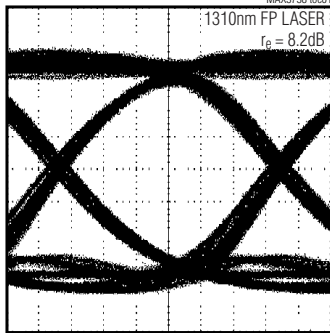

54ps/div

**OPTICAL EYE DIAGRAM
(1.25Gbps, 2⁷ - 1 PRBS, 940MHz FILTER)**

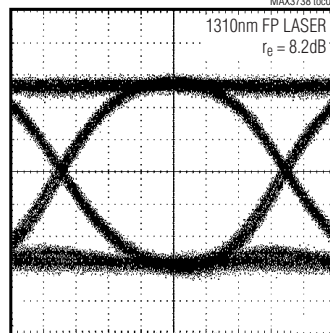

116ps/div

**ELECTRICAL EYE DIAGRAM
(I_{MOD} = 30mA, 2.7Gbps, 2⁷ - 1 PRBS)**

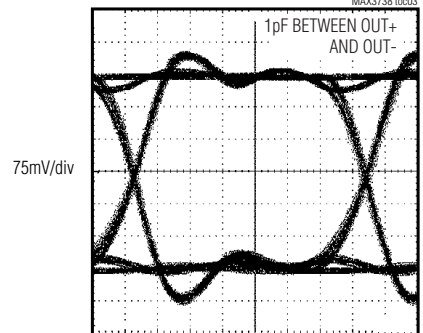

52ps/div

**SUPPLY CURRENT (I_{CC}) vs. TEMPERATURE
(EXCLUDES BIAS AND MODULATION CURRENTS)**

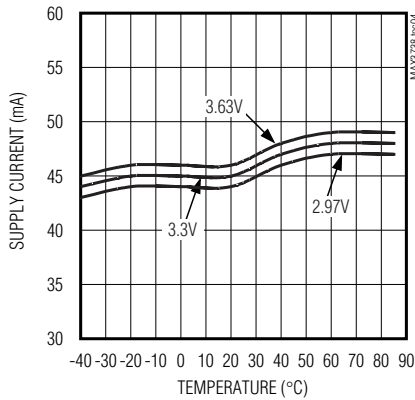

**BIAS-CURRENT MONITOR RATIO
vs. TEMPERATURE**

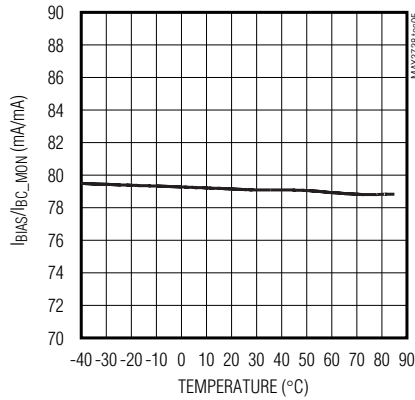

**PHOTOCURRENT MONITOR RATIO
vs. TEMPERATURE**

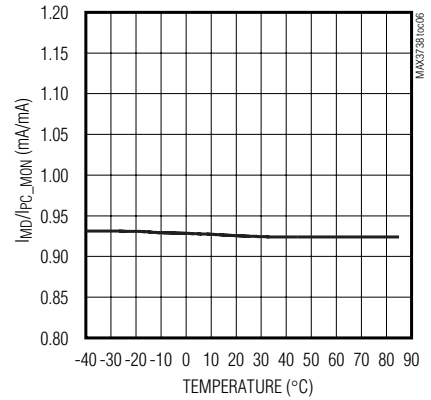

MODULATION CURRENT vs. R_{MODSET}

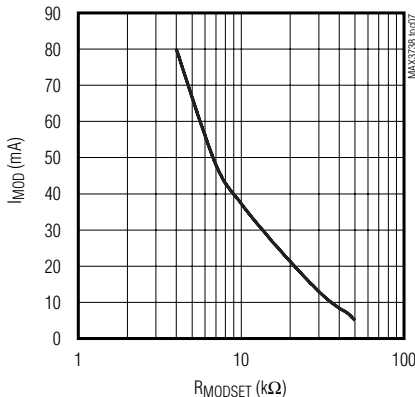

PHOTODIODE CURRENT vs. R_{APCSET}

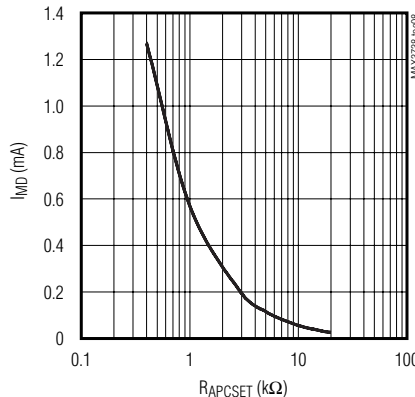

**DETERMINISTIC JITTER
vs. MODULATION CURRENT**

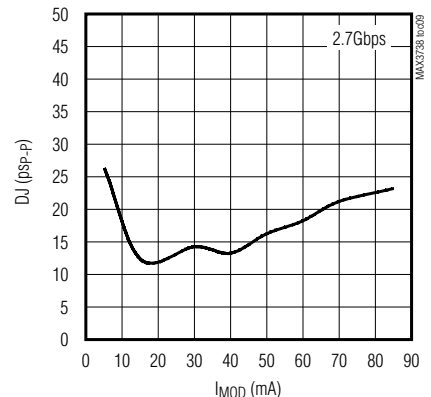

1Gbps至2.7Gbps SFF/SFP激光器驱动器， 带有消光比控制

典型工作特性 (续)

($V_{CC} = +3.3V$, $C_{APC} = 0.01\mu F$, $I_{BIAS} = 20mA$, $I_{MOD} = 30mA$, $T_A = +25^\circ C$, unless otherwise noted.)

MAX3738

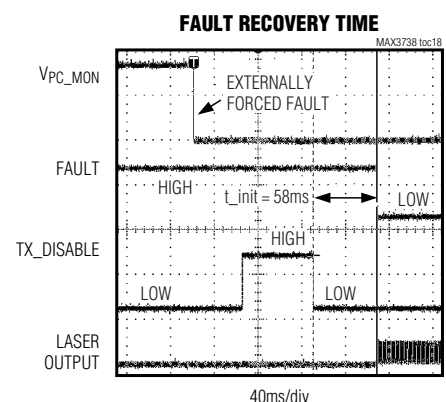
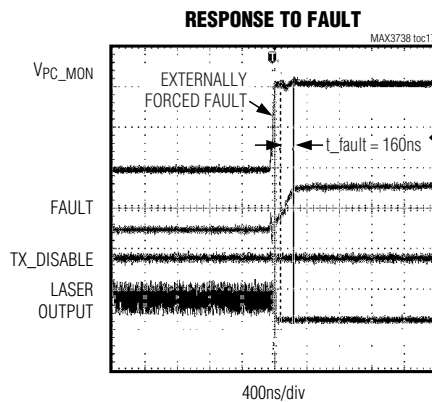
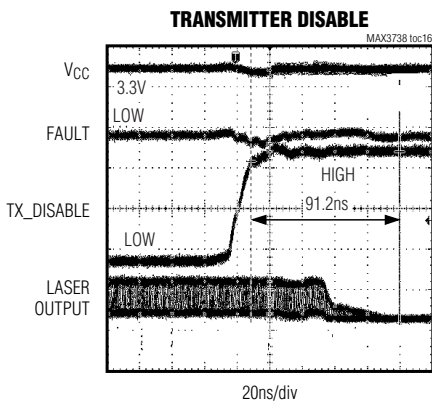
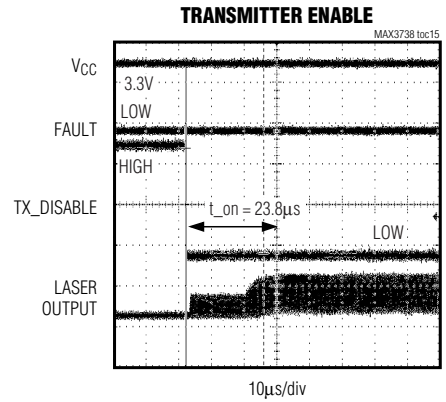
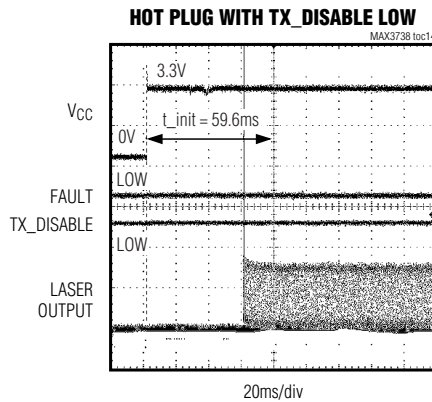
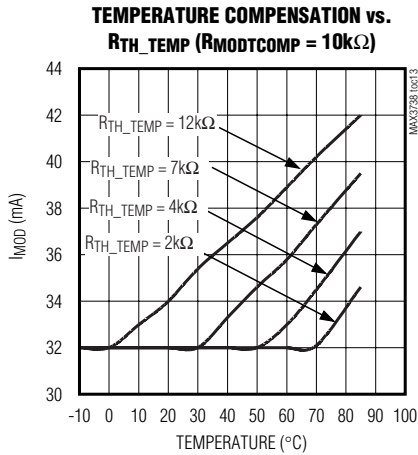
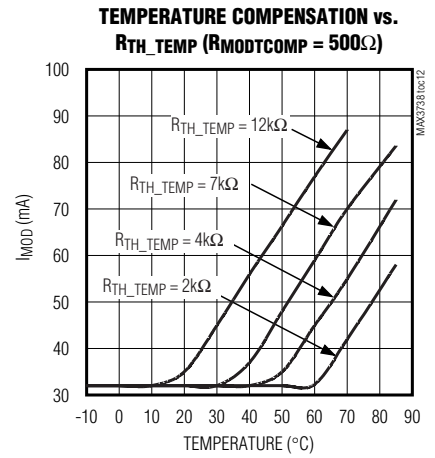
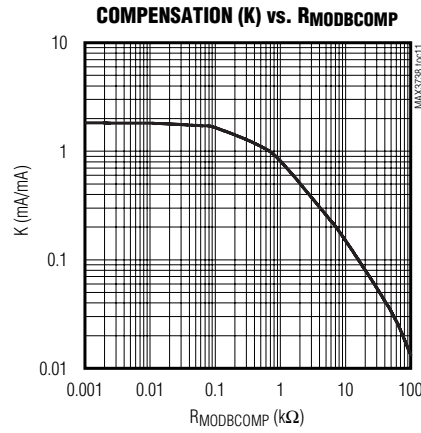
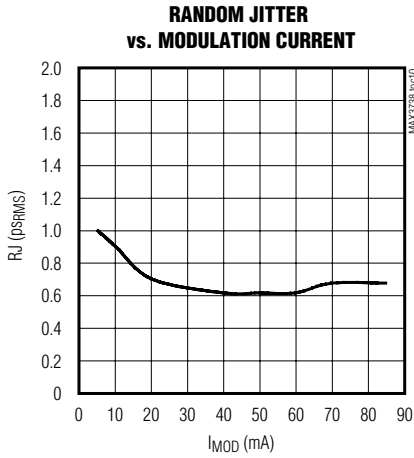

1Gbps至2.7Gbps SFF/SFP激光器驱动器， 带有消光比控制

引脚描述

引脚	名称	功能
1	MODTCOMP	调制电流温度补偿。该引脚的外部电阻设置在超出温度门限时的调制电流温度系数。无需温度补偿时，该引脚浮空。
2, 5, 14, 17	V _{CC}	+3.3V 电源。
3	IN+	同相数据输入。
4	IN-	反相数据输入。
6	TX_DISABLE	发送器禁止，TTL 电平。在TX_DISABLE为高电平或浮空时，激光器输出被禁止。该引脚为低电平时，允许激光器输出。
7	PC_MON	光电流监视器输出。该引脚输出电流通过一个外部电阻产生正比于监测二极管电流的、以地为参考的输出电压。
8	BC_MON	偏置电流监视器输出。该引脚输出电流通过一个外部电阻产生正比于偏置电流的、以地为参考的输出电压。
9	SHUTDOWN	关断驱动输出。电压输出控制外部晶体管，以选择关断某些电路。
10, 12	GND	地。
11	TX_FAULT	集电极开路输出的发送故障指示 (表1)。
13	BIAS	激光器偏置电流输出。
15	OUT-	调制电流反相输出。输入数据为低电平时，I _{MOD} 流入此引脚。
16	OUT+	调制电流同相输出。输入数据为高电平时，I _{MOD} 流入此引脚。
18	MD	监测光电二极管输入。该引脚接监测光电二极管的阳极。要求对地外接一只电容，以滤除高速交流监测光电流。
19	APCFILT1	在引脚19 (APCFILT1)和引脚20 (APCFILT2)之间连接一只电容，用于设置APC反馈回路的主极点。
20	APCFILT2	参见引脚19。
21	APCSET	在此引脚和接地之间连接一个电阻，用于设置所需的平均光功率。
22	MODSET	在此引脚和接地之间连接一个电阻，用于设置所需的恒定调制电流部分。
23	MODBCOMP	基于偏置的调制电流补偿。将偏置电流耦合至调制电流。I _{BIAS} 的镜像电流流过一个外部电阻。无需耦合时，该引脚浮空。
24	TH_TEMP	温度补偿门限。该引脚的外接电阻设置温度门限，超出该温度时将对调制电流进行补偿。
EP	Exposed Pad	地。将裸露焊盘焊接到电路板地，以达到指定的散热和电气特性。

1Gbps至2.7Gbps SFF/SFP激光器驱动器， 带有消光比控制



图1. 所需的输入信号和输出极性



图2. 特征参数的测试电路

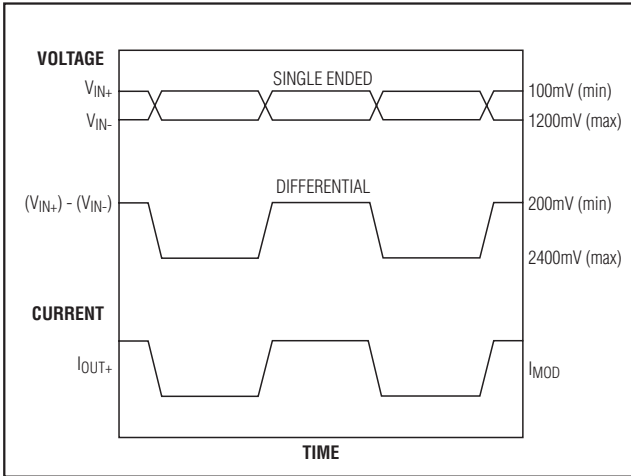

图3. 电源滤波器

详细说明

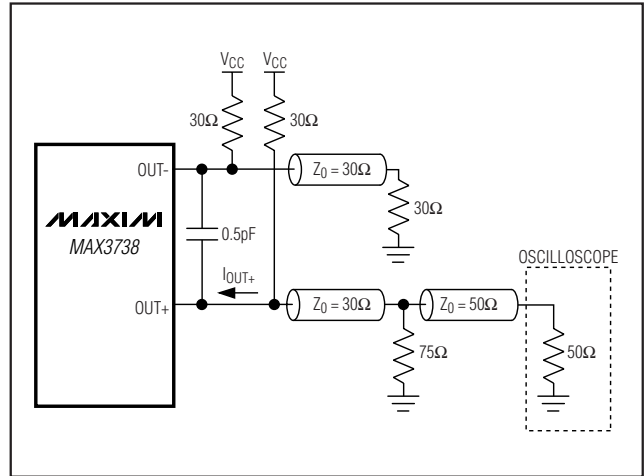
MAX3738 激光驱动器主要包括三个部分：高速调制驱动器、带ERC的偏置电流单元及保护电路。该电路设计优化用于高速、低压(+3.3V)工作方式(图4)。

高速调制驱动器

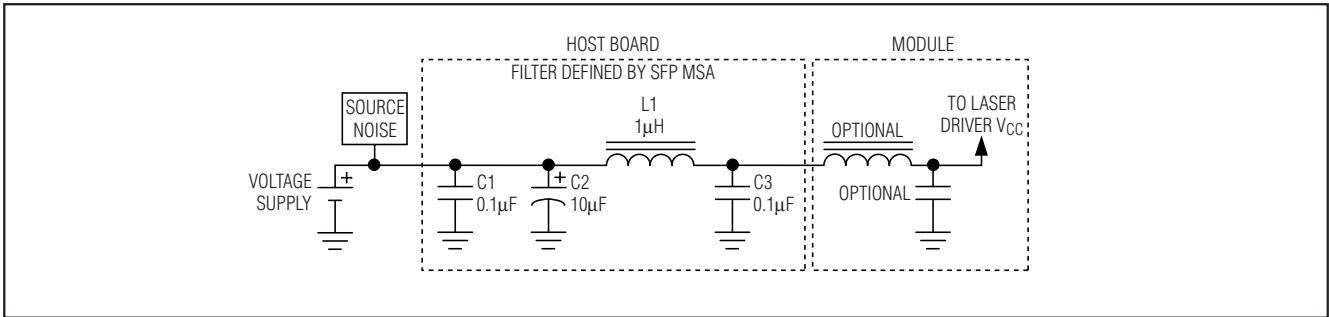
输出级由高速差分对和可编程调制电流源组成。MAX3738 针对驱动 15Ω 负载进行优化；要求调制电流达到 60mA 时，OUT+ 的最低瞬态电压为 0.7V；要求调制电流为 60mA 至 85mA 时，OUT+ 的最低瞬态电压为 0.75V。超过 60mA 运行时可采用交流耦合，保证激光器上具有足够的电压，以达到驱动器输出电压的要求。

为了与激光二极管连接，需采用一只阻尼电阻 (R_D) 进行阻抗匹配。串联阻尼电阻与激光二极管的等效串联电阻

总和应等于 15Ω。为减小由激光二极管寄生电感引起的过冲，可能需要一个 RC 并联网络。详细信息，请参考 Maxim 应用笔记 *HFAN 02.0: Interfacing Maxim's Laser Drivers to Laser Diodes*。

数据速率为 2.7Gbps 时，任何加载在激光二极管阴极的电容都会恶化光输出性能。由于 BIAS 输出直接与激光二极管阴极连接，可利用电感将 BIAS 引脚的寄生效应与激光器阴极隔离开，使该引脚的寄生电容最小。

消光比控制

消光比 (r_e) 为激光器导通状态的功率除以关断状态的功率。若峰值功率和平均功率保持不变，则消光比保持恒定：

$$r_e = (2P_{AVG} + P_{P-P}) / (2P_{AVG} - P_{P-P})$$

1Gbps至2.7Gbps SFF/SFP激光器驱动器， 带有消光比控制



图4. 功能图

通过APC调节平均功率，保持激光器耦合到光电二极管的电流恒定。激光器斜率效率(η)降低时，通过补偿调制电流能够在整个有效使用期限内和温度范围内保持峰值功率恒定：

$$P_{AVG} = I_{MOD} / P_{MON}$$

$$P_{P-P} = \eta \times I_{MOD}$$

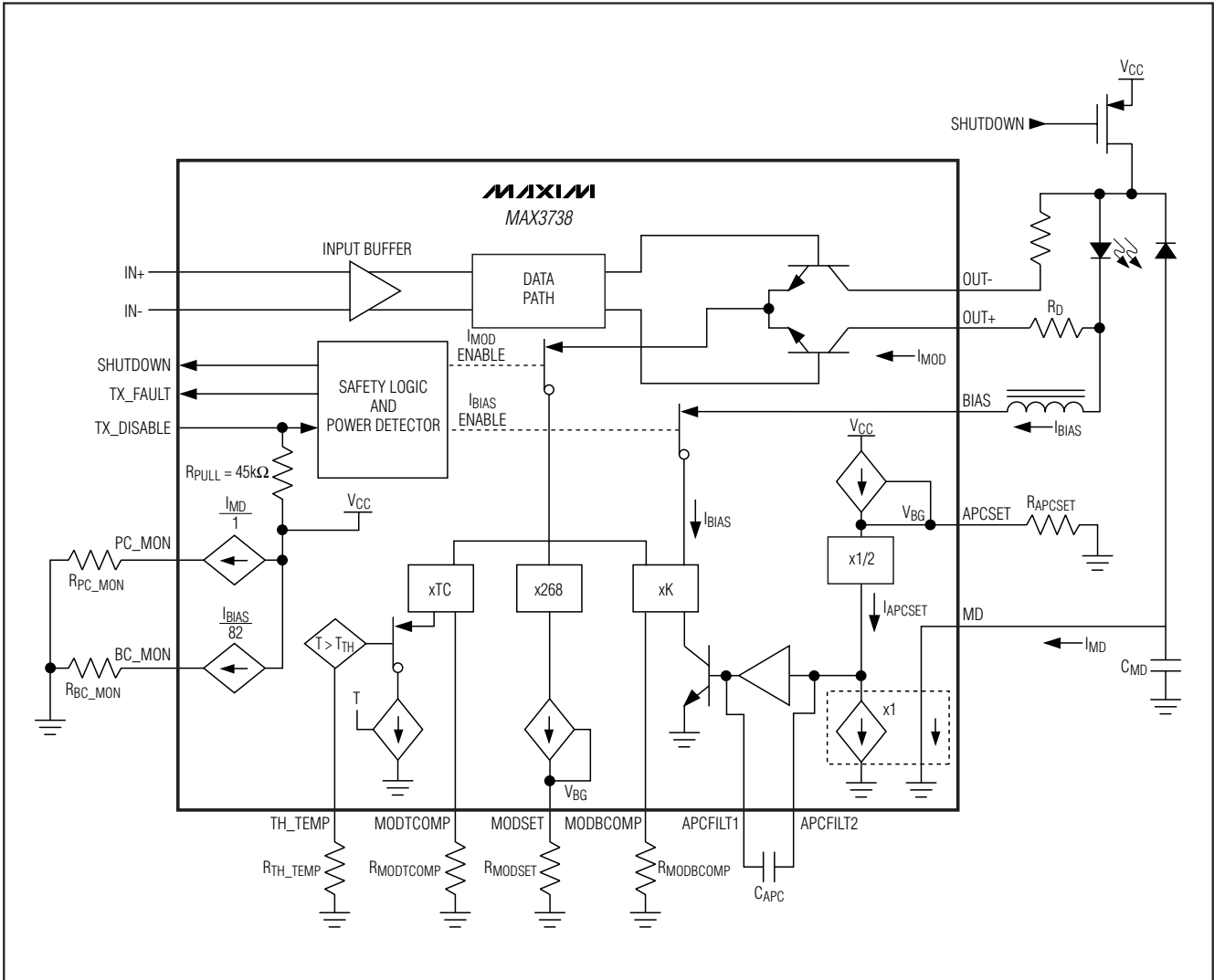
基于偏置的调制补偿按照用户选择的比例系数(K)调节调制电流，以便在偏置电流随温度升高而增大时，保持峰值光功率不变。详细资料请参考Maxim应用笔记HFAN-02.2.1。

$$K = \Delta I_{MOD} / \Delta I_{BIAS}$$

这提供了增大电流所需要的一次逼近，以保持峰值功率恒定。斜率效率随着温度的增加将明显降低。当温度超出用户定义的门限(T_{TH})时，MAX3738还可提供额外的温度补偿。

1Gbps至2.7Gbps SFF/SFP激光器驱动器， 带有消光比控制

MAX3738



图5. 简化的安全电路

表1. 典型故障条件

1	If any of the I/O pins are shorted to GND or V_{CC} (single-point failure; see Table 2), and the bias current or the photocurrent exceeds the programmed threshold.
2	End-of-life (EOL) condition of the laser diode. The bias current and/or the photocurrent exceed the programmed threshold.
3	Laser cathode is grounded and photocurrent exceeds the programming threshold.
4	No feedback for the APC loop (broken interconnection, defective monitor photodiode), and the bias current exceeds the programmed threshold.

1Gbps至2.7Gbps SFF/SFP激光器驱动器， 带有消光比控制

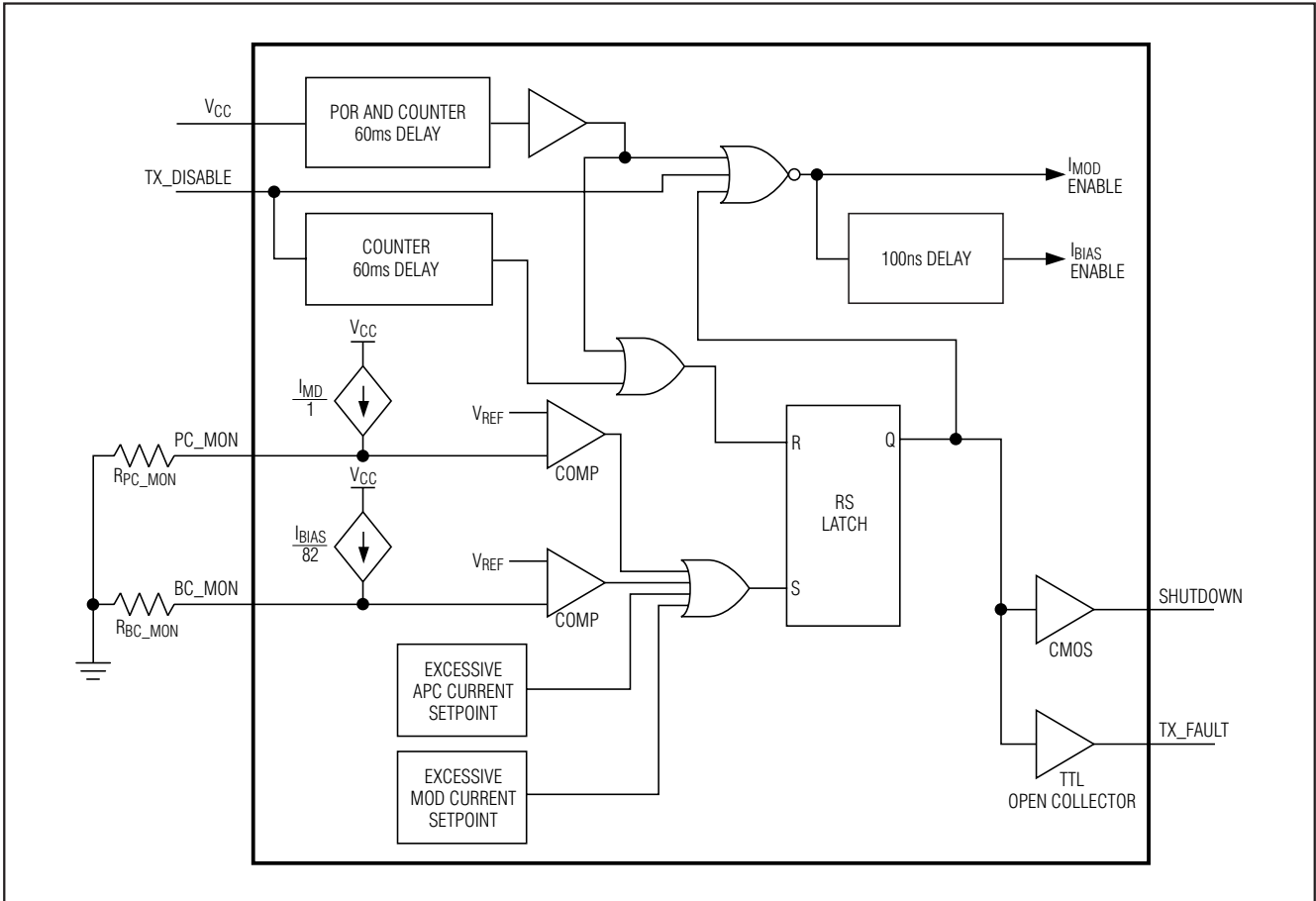
表2. 不同单点故障的电路响应

PIN	CIRCUIT RESPONSE TO OVERVOLTATGE OR SHORT TO V _{CC}	CIRCUIT RESPONSE TO UNDERVOLTAGE OR SHORT TO GROUND
TX_FAULT	Does not affect laser power.	Does not affect laser power.
TX_DISABLE	Modulation and bias currents are disabled.	Normal condition for circuit operation.
IN+	The optical average power increases, and a fault occurs if V _{PC_MON} exceeds the threshold. The APC loop responds by decreasing the bias current.	The optical average power decreases, and the APC loop responds by increasing the bias current. A fault state occurs if V _{BC_MON} exceeds the threshold voltage.
IN-	The optical average power decreases and the APC loop responds by increasing the bias current. A fault state occurs if V _{BC_MON} exceeds the threshold voltage.	The optical average power increases and a fault occurs if V _{PC_MON} exceeds the threshold. The APC loop responds by decreasing the bias current.
MD	This disables bias current. A fault state occurs.	The APC circuit responds by increasing the bias current until a fault is detected; then a fault* state occurs.
SHUTDOWN	Does not affect laser power. If the shutdown circuitry is used, the laser current is disabled.	Does not affect laser power.
BIAS	In this condition, the laser forward voltage is 0V and no light is emitted.	Fault state* occurs. If the shutdown circuitry is used, the laser current is disabled.
OUT+	The APC circuit responds by increasing the bias current until a fault is detected; then a fault state* occurs.	Fault state* occurs. If the shutdown circuitry is used, the laser current is disabled.
OUT-	Does not affect laser power.	Does not affect laser power.
PC_MON	Fault state* occurs.	Does not affect laser power.
BC_MON	Fault state* occurs.	Does not affect laser power.
APCFILT1	I _{BIAS} increases until V _{BC_MON} exceeds the threshold voltage.	I _{BIAS} increases until V _{BC_MON} exceeds the threshold voltage.
APCFILT2	I _{BIAS} increases until V _{BC_MON} exceeds the threshold voltage.	I _{BIAS} increases until V _{BC_MON} exceeds the threshold voltage.
MODSET	Does not affect laser power.	Fault state* occurs.
APCSET	Does not affect laser power.	Fault state* occurs.

*A fault state asserts the TX_FAULT pin, disables the modulation and bias currents, and asserts the SHUTDOWN pin.

安全电路

安全电路包括禁止输入 (TX_DISABLE)、锁存故障输出 (TX_FAULT) 和故障检测器 (图5)。该电路监视激光驱动器的工作状况，一旦检测到故障状态，就强行关断驱动器 (见表1)。根据SFP MSA的要求，TX_FAULT引脚应接一个4.7kΩ至10kΩ电阻上拉到V_{CC}。单点故障可以是与V_{CC}或GND的短路。有关电路对不同单点故障的响应情况参见表2。发送故障状态会一直被锁定，直到TX_DISABLE或V_{CC}引脚被触发复位。利用可选的关断电路，激光驱动器提供备用的激光二极管关断功能，参见典型应用电路。关断晶体管避免了由于激光器的单点故障而引发的不安全情况。

安全电路电流监测器

MAX3738能够监视 (BC_MON、PC_MON) 偏置电流 (I_{BIAS}) 和光电流 (I_{MD})。通过映射部分电流，并在外部接地电阻产生电压实现监视功能。当PC_MON或BC_MON的电压大于V_{REF}时，进入故障状态。例如，在每个监测器输出端接100Ω的电阻到地，可以得到以下电压：

$$V_{BC_MON} = (I_{BIAS} / 82) \times 100\Omega$$

$$V_{PC_MON} = I_{MD} \times 100\Omega$$

需要高精度测量偏置电流和光电二极管电流时，可以使用外部检测电阻。片内隔离电阻减少了实现该功能所需要的元件数量。

1Gbps至2.7Gbps SFF/SFP激光器驱动器， 带有消光比控制

表3. 光功率关系式

PARAMETER	SYMBOL	RELATION
Average Power	P_{AVG}	$P_{AVG} = (P_0 + P_1) / 2$
Extinction Ratio	r_e	$r_e = P_1 / P_0$
Optical Power of a One	P_1	$P_1 = 2P_{AVG} \times r_e / (r_e + 1)$
Optical Power of a Zero	P_0	$P_0 = 2P_{AVG} / (r_e + 1)$
Optical Amplitude	P_{P-P}	$P_{P-P} = P_1 - P_0$
Laser Slope Efficiency	η	$\eta = P_{P-P} / I_{MOD}$
Modulation Current	I_{MOD}	$I_{MOD} = P_{P-P} / \eta$
Threshold Current	I_{TH}	P_0 at $I \geq I_{TH}$
Bias Current (AC-Coupled)	I_{BIAS}	$I_{BIAS} \geq I_{TH} + I_{MOD} / 2$
Laser to Monitor Transfer	ρ_{MON}	I_{MD} / P_{AVG}

Note: Assuming a 50% average input duty cycle and mark density.

设计步骤

设计激光发射器时，通常用平均功率和消光比表示光输出。表3列出的关系式有助于平均光功率和调制电流之间的换算。在光信号的符号密度和占空比为50%时，这些关系式有效。

给定激光功率 (P_{AVG})、斜率效率 (η) 和消光比 (r_e)，可根据表3计算偏置电流和调制电流。为了适当设置这些电流，需要了解激光器特性，以监视传输效率 (ρ_{MON}) 和斜率效率 (η)。

设置监测二极管电流

MAX3738 在任何时候都工作在APC模式。偏置电流将自动设置，使平均光功率由APCSET的外部电阻确定：

$$P_{AVG} = I_{MD} / \rho_{MON}$$

APCSET引脚控制监测二极管电流的设置点。内部电流调节器以与MODSET相同的方式建立APCSET电流。参考典型工作特性中 I_{MD} 与 R_{APCSET} 的关系曲线，选择+25°C下所需电流对应的 R_{APCSET} 值。

$$I_{MD} = 1/2 \times V_{REF} / R_{APCSET}$$

激光驱动器自动调整偏置，以保持恒定的平均功率。对于直流耦合的激光二极管：

$$I_{AVG} = I_{BIAS} + I_{MOD} / 2$$

设置带补偿的调制电流

由激光器的斜率效率决定调制电流：

$$I_{MOD} = 2 \times P_{AVG} / \eta \times (r_e - 1) / (r_e + 1)$$

MAX3738的调制电流包括：静态调制电流 (I_{MODS})、与 I_{BIAS} 成正比的电流和与温度成正比的电流。由MODSET设置的 I_{MOD} 电流通过内部电流调节器建立，保持外部编程电阻上电压为 V_{REF} 。参考典型工作特性中 I_{MOD} 与 R_{MODSET} 的关系曲线，选择+25°C下所需电流对应的 R_{MODSET} 值。

$$I_{MOD} = I_{MODS} + K \times I_{BIAS} + I_{MODT}$$

$$I_{MODS} = 268 \times V_{REF} / R_{MODSET}$$

$$I_{MODT} = TC \times (T - T_{TH}) \quad I T > T_{TH}$$

$$I_{MODT} = 0 \quad I T \leq T_{TH}$$

MODBCOMP引脚的外部电阻用来设置与 I_{BIAS} 成比例的电流。MODBCOMP引脚开路将断开 I_{BIAS} 与 I_{MOD} 之间的耦合关系：

$$K = 1700 / (1000 + R_{MODBCOMP}) \pm 10\%$$

若 I_{MOD} 必须从 I_{MOD1} 增加到 I_{MOD2} ，以便使消光比在高温下保持不变，所需补偿系数为：

$$K = (I_{MOD2} - I_{MOD1}) / (I_{BIAS2} - I_{BIAS1})$$

附加温度补偿的门限通过 T_{H_TEMP} 引脚的电阻设置：

$$T_{TH} = -70^\circ\text{C} + 1.45\text{M}\Omega / (9.2\text{k}\Omega + R_{T_{H_TEMP}})^\circ\text{C} \pm 10\%$$

超过 T_{TH} 时，温度补偿系数由 $R_{MODTCOMP}$ 设置。MODTCOMP引脚开路将禁止附加的温度补偿：

$$TC = 1 / (0.5 + R_{MODTCOMP}(\text{k}\Omega)) \text{ mA}/^\circ\text{C} \pm 10\%$$

1Gbps至2.7Gbps SFF/SFP激光器驱动器， 带有消光比控制

电流条件 ($I_{MOD} \leq 60\text{mA}$),
直流耦合

OUT+和OUT-上的最小电压为0.7V。

对于:

V_{DIODE} = 二极管偏置电压 (1.2V 典型值)

R_L = 二极管偏置电阻 (5Ω 典型值)

R_L = 串联匹配电阻 (20Ω 典型值)

为了满足电流条件:

$$V_{OUT+} = V_{CC} - V_{DIODE} - I_{MOD} \times (R_D + R_L) - I_{BIAS} \times R_L \geq 0.7V$$

电流条件 ($I_{MOD} > 60\text{mA}$),
交流耦合

对于要求调制电流大于60mA的应用来说，如果激光器采用直流耦合，留出的空间将不足以保证激光器的正常运行。为避免该问题的发生，MAX3738的调制输出可通过交流耦合至激光二极管的阴极。这就需要一只外部上拉电感，将调制输出直流偏置在 V_{CC} 。这种配置将激光器正向电压与输出电路隔离，并允许OUT+输出在供电电压(V_{CC})处上下波动。采用交流耦合时，MAX3738调制电流可以设置到85mA。有关交流耦合激光驱动器与激光二

极管的详细信息，请参考Maxim应用笔记HFAN 02.0: *Interfacing Maxim's Laser Driver to Laser Diodes*。为满足电流条件:

$$V_{OUT+} = V_{CC} - I_{MOD} / 2 \times (R_D + R_L) \geq 0.75V$$

确定 C_{APC}

必须合理选择APC环路滤波电容 C_{APC} ，以平衡快速开启和减小低频时数据模板相互影响的要求。低频截止电容为:

$$C_{APC}(\mu F) \cong 68 / (f_{3dB}(\text{kHz}) \times (\eta \times \rho_{MON})^{1.1})$$

高频噪声可用MD引脚与地之间的外部电容 C_{MD} 滤除:

$$C_{MD} \cong C_{APC} / 4$$

设计MAX3738，以便开启时间小于1ms，以适合大多数激光器增益($\eta \times \rho_{MON}$)。选择更小的 C_{APC} 值，将缩短开启时间。对于某些激光器增益，在低数据速率下需要仔细考虑开启时间和低频截止。

接口模型

图6和图7给出了简化的MAX3738激光驱动器的输入和输出电路。若采用裸片，则采用绑定线寄生参数代替封装寄生参数。



图6. 简化的输入结构



图7. 简化的输出结构

1Gbps至2.7Gbps SFF/SFP激光器驱动器， 带有消光比控制

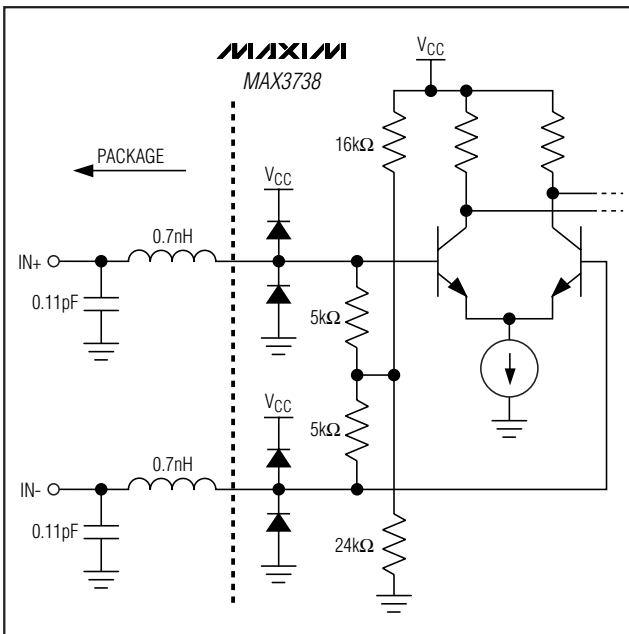
MAX3738

布局考虑因素

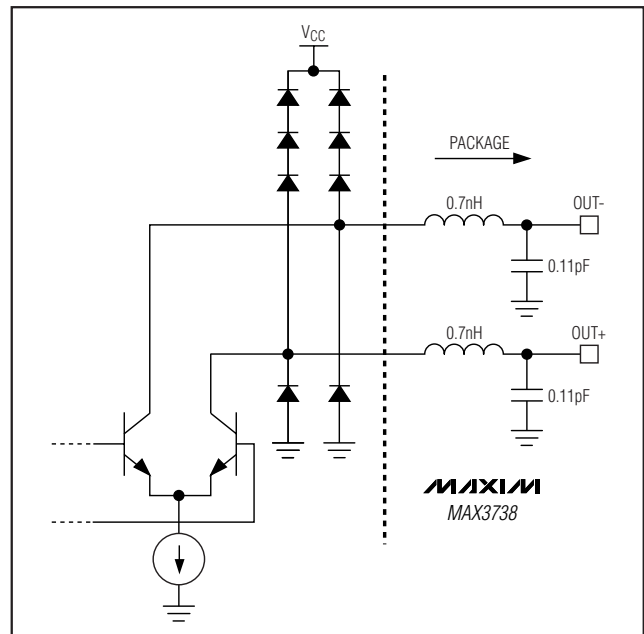
为尽可能降低损耗和串扰，应保持MAX3738输出与激光二极管之间尽可能短的连线。采用良好的高频布局技巧和带有不间断地线层的多层电路板，以最小化EMI和串扰。应该采用低损耗绝缘电路板。同时，数据输入和模块输出应该采用阻抗受控的传输线。

裸露焊盘 (EP) 封装

24引脚QFN的裸露焊盘提供了一个很低的热阻通路，有助于IC散热。该焊盘同时也是MAX3738的电气地，必须被焊接至电路板地，以获得良好的散热性能和电气性能。详细信息，请参考Maxim应用笔记HFAN-08.1: *Thermal Consideration for QFN and Other Exposed-Pad Packages*，应用笔记可从www.maxim-ic.com网站获得。

激光器安全性和IEC 825

单独采用MAX3738激光驱动器并不保证发射器的设计符合IEC825标准。必须仔细考虑整个发射器电路及器件选择。每个用户必须明确具体应用所要求的容错等级，确保Maxim产品不会作为系统的一个部分被设计或使用到外科移植手术，用于支撑或维持生命，或其它任何可能因为Maxim产品失效所导致的人体伤害、甚至死亡的应用领域。

芯片信息

TRANSISTOR COUNT: 1884

PROCESS: SiGe/Bipolar

典型工作电路

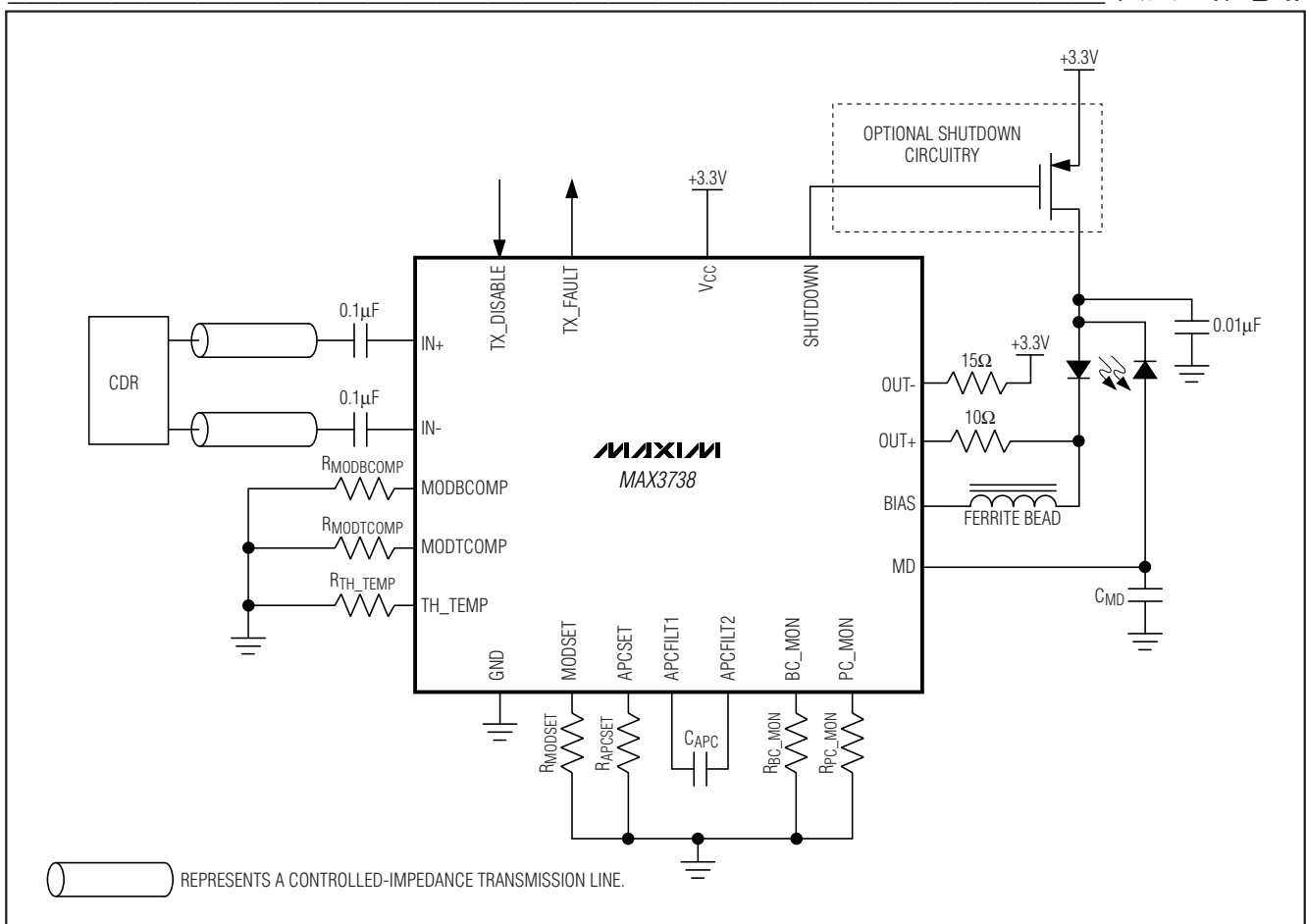

1Gbps至2.7Gbps SFF/SFP激光器驱动器， 带有消光比控制

封装信息 (续)

(本数据资料提供的封装图可能不是最近的规格，如需最近的封装外型信息，请查询 www.maxim-ic.com/packages。)

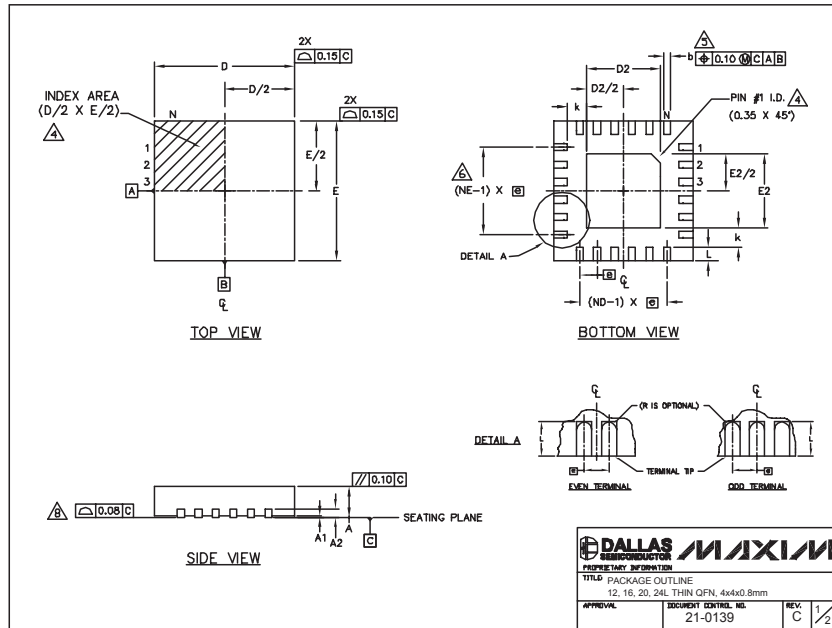

COMMON DIMENSIONS												
PKG REF.	12L 4x4			16L 4x4			20L 4x4			24L 4x4		
	MIN.	NDM.	MAX.	MIN.	NDM.	MAX.	MIN.	NDM.	MAX.	MIN.	NDM.	MAX.
A	0.70	0.75	0.80	0.70	0.75	0.80	0.70	0.75	0.80	0.70	0.75	0.80
AL	0.0	0.02	0.05	0.0	0.02	0.05	0.0	0.02	0.05	0.0	0.02	0.05
A2	0.20 REF			0.20 REF			0.20 REF			0.20 REF		
b	0.25	0.30	0.35	0.25	0.30	0.35	0.20	0.25	0.30	0.18	0.23	0.30
D	3.90	4.00	4.10	3.90	4.00	4.10	3.90	4.00	4.10	3.90	4.00	4.10
E	3.90	4.00	4.10	3.90	4.00	4.10	3.90	4.00	4.10	3.90	4.00	4.10
φ	0.80 BSC			0.65 BSC			0.50 BSC			0.50 BSC		
k	0.25	-	-	0.25	-	-	0.25	-	-	0.25	-	-
L	0.45	0.55	0.65	0.45	0.55	0.65	0.45	0.55	0.65	0.30	0.40	0.50
N	12			16			20			24		
ND	3			4			5			6		
NE	3			4			5			6		
WDRG Var.	WGGB			WGGC			WGGD-1			WGGD-2		

EXPOSED PAD VARIATIONS											
PKG CODES	D2			E2			DOWN BEND ALLOWED				
	MIN.	NDM.	MAX.	MIN.	NDM.	MAX.					
T1244-2	1.95	2.10	2.25	1.95	2.10	2.25	NO				
T1244-3	1.95	2.10	2.25	1.95	2.10	2.25	YES				
T1244-4	1.95	2.10	2.25	1.95	2.10	2.25	NO				
T1644-2	1.95	2.10	2.25	1.95	2.10	2.25	NO				
T1644-3	1.95	2.10	2.25	1.95	2.10	2.25	YES				
T1644-4	1.95	2.10	2.25	1.95	2.10	2.25	NO				
T2044-1	1.95	2.10	2.25	1.95	2.10	2.25	NO				
T2044-2	1.95	2.10	2.25	1.95	2.10	2.25	YES				
T2044-3	1.95	2.10	2.25	1.95	2.10	2.25	NO				
T2444-1	2.45	2.60	2.63	2.45	2.60	2.63	NO				
T2444-2	1.95	2.10	2.25	1.95	2.10	2.25	YES				
T2444-3	2.45	2.60	2.63	2.45	2.60	2.63	YES				
T2444-4	2.45	2.60	2.63	2.45	2.60	2.63	NO				

NOTES:

- DIMENSIONING & TOLERANCING CONFORM TO ASME Y14.5M-1994.
- ALL DIMENSIONS ARE IN MILLIMETERS. ANGLES ARE IN DEGREES.
- N IS THE TOTAL NUMBER OF TERMINALS.
- THE TERMINAL #1 IDENTIFIER AND TERMINAL NUMBERING CONVENTION SHALL CONFORM TO JEDEC 95-1 SFF-012. DETAILS OF TERMINAL #1 IDENTIFIER ARE OPTIONAL, BUT MUST BE LOCATED WITHIN THE ZONE INDICATED. THE TERMINAL #1 IDENTIFIER MAY BE EITHER A MOLD OR MARKED FEATURE.
- DIMENSION b APPLIES TO METALLIZED TERMINAL AND IS MEASURED BETWEEN 0.25 mm AND 0.30 mm FROM TERMINAL TIP.
- ND AND NE REFER TO THE NUMBER OF TERMINALS ON EACH D AND E SIDE RESPECTIVELY.
- DEPOPULATION IS POSSIBLE IN A SYMMETRICAL FASHION.
- COPLANARITY APPLIES TO THE EXPOSED HEAT SINK SLUG AS WELL AS THE TERMINALS.
- DRAWING CONFORMS TO JEDEC MO220, EXCEPT FOR T2444-1, T2444-3 AND T2444-4.

DALLAS MAXIM PROPRIETARY INFORMATION	
TITLE: PACKAGE OUTLINE	
12, 16, 20, 24L THIN OFN, 4x4x0.8mm	
APPROVAL	DOCUMENT CONTROL NO. 21-0139
REV. C	2/2

Maxim 不对 Maxim 产品以外的任何电路使用负责，也不提供其专利许可。Maxim 保留在任何时间、没有任何通报的前提下修改产品资料和规格的权利。

14 **Maxim Integrated Products, 120 San Gabriel Drive, Sunnyvale, CA 94086 (408) 737-7600**