

内含有源整流器的升/降压直流—直流变换器

武汉力源单片机技术研究所(430010) 胡 戎

摘 要: 介绍升压/降压直流—直流变换器 MAX877/878/879 的工作原理、特性,并给出典型应用电路

关键词: 有源整流器 升压/降压直流—直流变换器 应用举例

MAX877/878/879 是一种脉冲跳越(puls-skip-ping)升压/降压直流—直流变换器,它在输入电压高于或低于输出电压的情况下,均可提供一个稳定的输出电压,所需的外部元件仅三个——一个电感和二个滤波电容。MAX877 在输入电压为 2.5V 到 6.2V 时提供一路 5V 稳压输出;MAX878 在输入电压为 1.5V 到 6.2V 时,通过选择端,可提供 3.0V 或 3.3V 的稳压输出;MAX879 在输入电压为 1.5V 到 6.2V 时,通过外部的电阻分压器,可获得 2.5V 到 6V 的可调稳压输出。上述器件的变换效率可高达 85%,并可确保 210mA 的负载电流。

图 1 是一般升压变换器的结构原理图,可以看出,由于输入经电感和二极管与输出之间有一直流通路,故即使变换器处

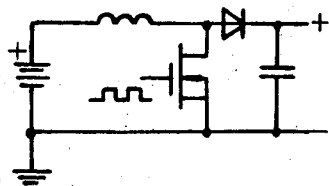

于关断模式,其输出电压也不会为零,而是等于 $V_{IN} - V_{DIODE}$,这会在输入与输出间形成泄漏电流。

MAX877/878/879 内置一个独特的高功率有源整流器,它处在一般升压变换器二极管(通常是外置的)的位置,当输入电压高于所设计的输出电压时,器件在类似线性调节器的模式下降压工作;当输入电压低于输出电压时,器件平滑地切换到脉冲跳越升压模式工作,并能将低至 1V 的输入电压提升起来。在关断模式,有源整流器可将输出与输入隔离开,从而消除了一般升压变换器从输入到输出的泄漏电流。

MAX877/878/879 的操作频率高达 300kHz,从而允许使用体积较小的表面贴装电感。器件在空载时的供电电流为 195 μ A,关断模式时,供电电流仅为 20 μ A。与其具有类似特性和相同引脚的 1 个电池(1V)升压变换器的型号是 MAX777/778/779。

1 引脚及封装

MAX877/878/879 可提供 8 脚双列直插封装和 8

脚 SO 等多种封装,其引脚排列如图 2 所示。工作温度有 0 $^{\circ}$ C 至 +70 $^{\circ}$ C(民用级),-40 $^{\circ}$ C 至 +85 $^{\circ}$ C(工业级)以及 -55 $^{\circ}$ C 至 +125 $^{\circ}$ C(军用级)。表 1 是器件引脚说明。

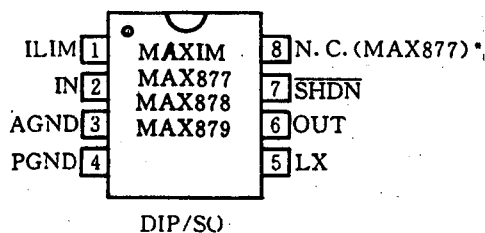

* SEL(MAX878), FB(MAX879)

图 2 MAX877/878/879 引脚排列 *

2 工作原理

MAX877/878/879 开关调节器由一个 NPN 双极性功率开关管和电流限制器,一个精密电压基准和一个有源整流器组成,其结构框图如图 3 所示。

MAX877/878/879 采用最小关断时间,电流限制脉冲频率调制(PFM)的控制模式工作,这种模式兼备有脉宽调制(PWM)的高功率及高效率和传统 PFM 脉冲跳越低静态电流的优点,外部条件(电感值,负载和输入电压)决定了该种器件的变换操作,下面详细说明。

2.1 在轻载时

电感内的电流由零开始上升到峰值,并在一个周期跌落至零(非连续传导方式)。在这种情况下,开关频率取决于一对单稳触发器,由它们设置一个与 V_{IN} 成反比的最大接通时间 [$t_{ON} = 8.8 / (V_{IN} - 0.25)$] 和一个最小关断时间(对于 MAX877/MAX879 为 1.3 μ s,对于 MAX878 为 2.3 μ s)。对于 22 μ H 的电感,LX 的峰值电流大约为 400mA 并与输入电压无关。在轻载时由于低的峰值电流而使效率得到改善。

2.2 在极轻负载时

在这种情况下下一个周期内线圈中储存的能量大于负载所需要的能量,变换器通过跳跃整个周期来调节输出电压,在脉冲跳跃模式下典型效率为 65%到

75%。脉冲跳跃的波形可以是不规则的,并且其输出波形中含有低频成份,如果需要,可使大容量、低等效串联电阻的滤波电容来减小纹波。

表 1 器件引脚说明

引脚	名称	功能
1	ILIM	设置开关电流限制输入。若连至 IN 脚,则有 1A 的电流限制;若在 ILIM 和 IN 这间接一个电阻,则可将电感峰值电流限制在较低的值
2	IN	电源输入
3	AGND	模拟地,内部未连至 PGND
4	PGND	电源地,与 AGND 一起直接焊接到地
5	LX	1A NPN 功率开关集电极和 PNP 有源整流器发射极
6	OUT	电压主输出端,滤波电容要紧靠该脚连接
7	SHDN	关断控制脚,为低时阻断电源供给,同时将负载与输入断开。关断的阈值电压为 $V_{IN}/2$,正常工作时连至输入 IN
8	N.C (MAX877)	空脚,无内部连接
	SEL (MAX878)	主输出电压选择脚,当接 AGND 时为 3.3V 输出;当空接时为 3.0V 输出
	FB (MAX879)	可调输出操作的反馈输入脚,它连接到 V_{OUT} 和 AGND 之间的外部分压器上

2.3 在重负载时

在大约 100mA 的重负载时,变换器进入连续导流模式,这时电感中总是有电流流动,开关的接通状态是以基本周期为单位一周一周地,或以最大接通时间

$t_{ON(MAX)}$,或以预置的开关电流限制来控制,这可防止开关内的电流超过定值或电感进入饱和。在极重负载下,电感中电流在峰值电流限制值和某个更低的值之间自激振荡,实际数值取决于最小空闲时间、电感值和输入输出的电压差。

3 有源整流器和降压工作模式

MAX877/878/879 内部的有源整流器取代了通常升压操作中的肖特基二极管,该整流器由一个 PNP 通道晶体管和一个独特的控制电路组成,这个电路在关断模式下可将负载与输入电压完全断开,这是明显优于通常升压调节器的设计之处,因为它防止了在关断情况下电池的泄漏。MAX877/878/879 在正常操作时,其输出可承受短时的断路。

MAX877/878/879 的另一个特性是同时具备升压/降压模式,这在电池供电中特别有用,因为电池的初始电压可能超过输出电压,以后又会降落到输出电压以下。例如,用 MAX877 将四节串联碱性电池的电压调节到 +5V 输出即是这种情况。当输入电压高于输出电压,MAX877/878/879 相当于一个“开关”型的线性调节器,如果输出电压开始下降,开关会接通,能量被存储在线圈中,就象是工作在通常的升压模式。开关关闭以后,LX 端的电压升高,当升高到超过 V_{IN} 时,其工作象一个线性调节器。 V_{IN} 和 V_{OUT} 之间的电压差降落在整流器上(实为一个 PNP 晶体管),直到其电流为零或整流器被关闭。当 MAX877/878/879 在降压变换



图 3 MAX878 结构框图

时,其效率类似于一个线性调节器,最大的输出电流 $I_{OUT(MAX)}$ 受器件封装耗散功率的限制,并取决于最大的输入输出差, $I_{OUT(MAX)}$ 可近似地表达如下:

$$I_{OUT(MAX)} \approx \left(\frac{P_{DISS}}{V_{IN} - V_{OUT}} \right) \times 0.9$$

当输入电压跌落至接近所设计的输出电压值时,变换器控制电路将确保它平滑地切换到升压变换模式。

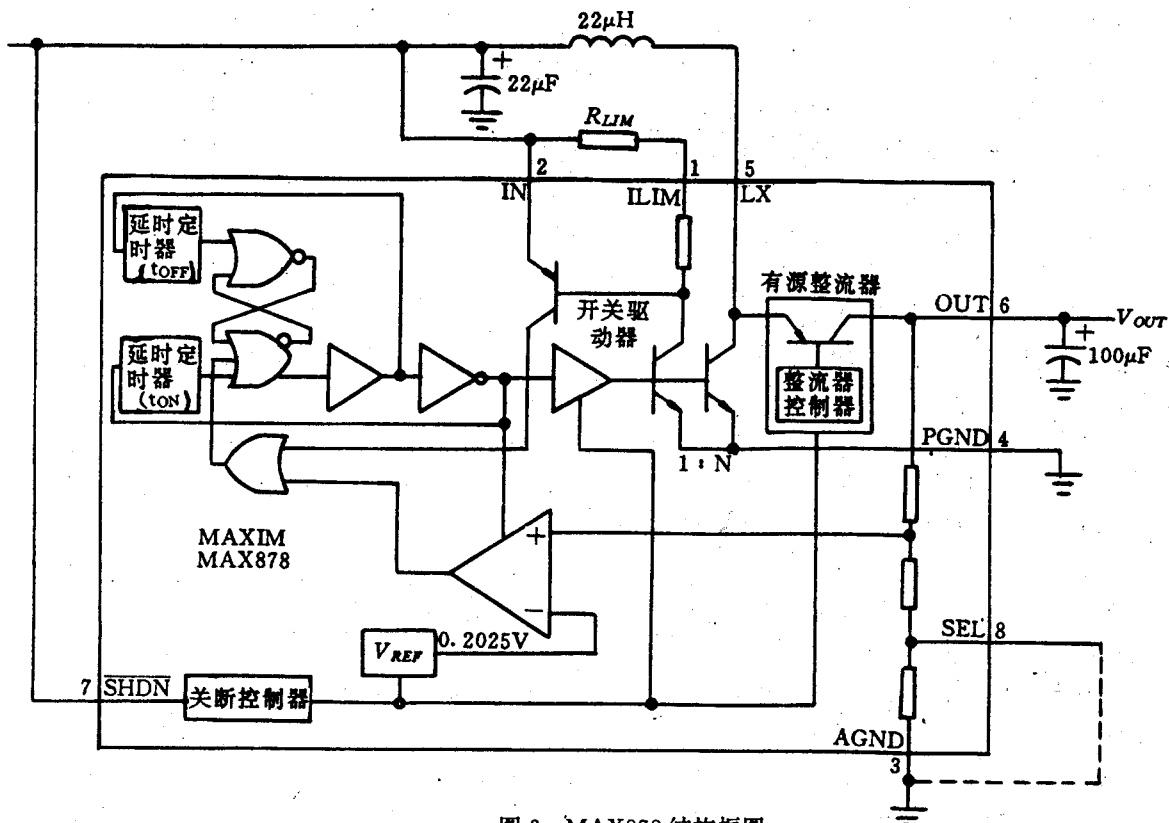
4 关断模式

SHDN是一个高阻抗输入端,低电平输入有效,正常操作将其连至输入 IN。若SHDN保持低,器件进入关断模式,由于这时有源整流器被关闭,输入到负载的通路被切断,输出可有效地降到 0V。关断模式下器件的供电电流范围从 $4\mu A$ ($V_{IN}=1V$) 到 $50\mu A$ ($V_{IN}=5V$)。关断电路的门限值通常被设置在 $V_{IN}/2 + 250mV$,当SHDN的输入低于该门限值时,器件关断;当高于该门限时,器件使能。当由外部逻辑驱动时,SHDN的驱动电平可高于 V_{IN} (最大 6.2V)。

5 电流限制

当 ILIM 脚连至 IN 时, LX 的电流被限制在 1A。然而,对于较小的输出功率,无需最大的峰值电流,减少电感峰值电流的方法是在 ILIM 和 IN 之间连一个电阻,这可优化总体效率,并且可选用很小的,具有更低电流额定值的低成本电感。

6 应用举例

MAX877/878/879 解决了 4 个电池到 5V 或 3 个电池到 3V/3.3V 的升/降压调节问题,因此,可广泛应用于各种电池供电系统。MAX877/878/879 的使用简单到仅需三个外部元件,图 4 是它们的应用电路图。

6.1 电感选择

通常一个 $22\mu H$ 的电感对多数 MAX877/878/879 的设计是足够的,电感值范围在 $10\mu H$ 到 $47\mu H$ 也是适合的。电感的饱和和电感电流要等于或大于电感的峰值电流,在无外部电流限制情况下(ILIM 接 IN)峰值电流为 1A。电感在其饱和度 120% 的情况工作也是可接受的,但是,这会略微减少效率。为了获得最高的效率,要使用低直流电阻的电感,最好是在 0.2Ω 以下。

6.2 电容选择

在典型应用电路中, $100\mu F/10V$ 表面贴装(SMT) 输出电容将会引起 25mV 或更小的输出纹波,这是在 3V 到 5V 及 200mA 升压操作条件下。在轻载或是允许较大纹波的应用场合,小到 $10\mu F$ 的输出电容也是可接受的。如果电压源的输出阻抗较低,并且输入导线短于 2 英寸(5cm),或者负载较小,输入电容也可忽略。

6.3 输出电压选择

MAX879 的输出电压由二个电阻 R_1 和 R_2 设置(见图 4C),它们在输出与 FB 脚间组成一个电压分压

器,输出电压可由下式设置在 2.5V 到 6.0V 之间:

$$V_{OUT} = V_{REF} \frac{(R_1 + R_2)}{R_2}$$

其中 $V_{REF} = 0.2025V$

上式中 R_2 的取值在 10K 到 50K 较适合,图 4C 中 R_1 上并联的电容起稳定电路工作和减小输出纹波的作用。FB 端导线的长度和电路的印制线要尽量短。



图 4 MAX877/878/879/典型应用电路

通过以上讨论可以看出 MAX877/878/879 (输入电压更低的同类产品是 MAX777//778/779) 较普通开关型升压器具有以下二个优点。其一是用一个内置的有源整流器取代了通常外置的肖特基二极管,这不仅可简化电路结构和减少电路尺寸,更重要的是在关断模式下可防止电池的泄漏电流。其二是该种升压变换器同时可工作在降压模式,从而有效地解决了 4 节电池到 5V 或 3 节电池到 3V/3.3V 的升/降压调节问题。

(收稿日期:1995-09-12)

3V模拟低功耗产品

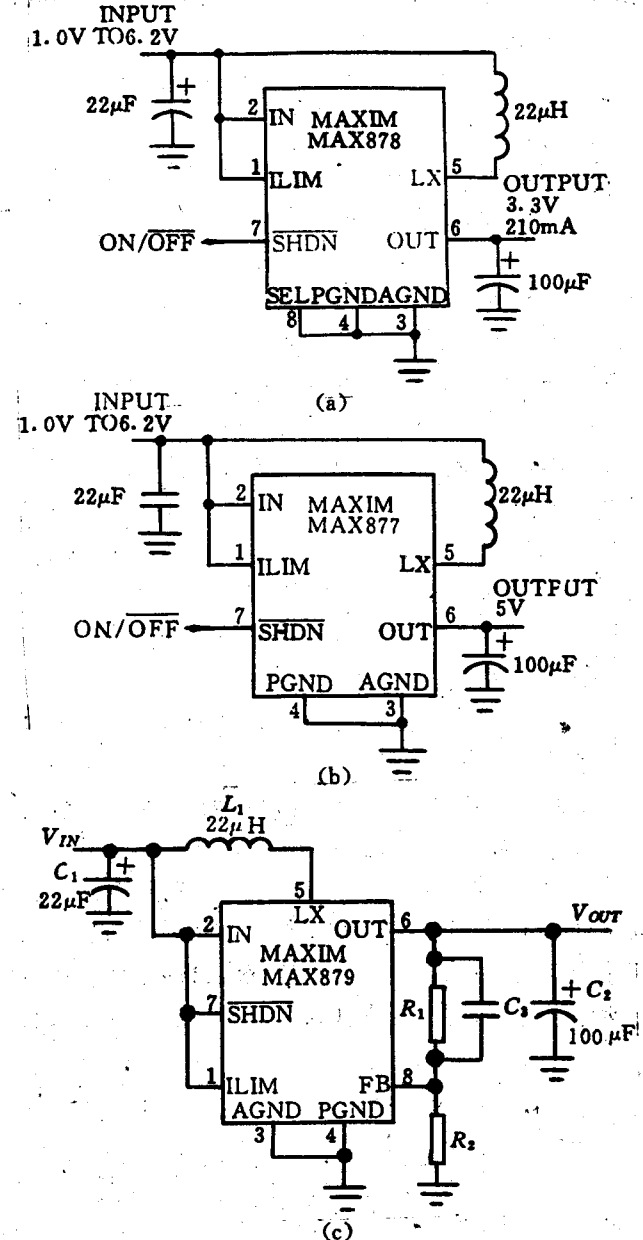
DC-DC 变换器

器件号	输入电压范围(V)	输出电压范围(V)	静态电源电流(mA), 最大(典型)	输出(mA 典型)	封装选项	评估器件	温度范围**	特点	1000片以上美元价(\$)
升压降压开关型稳压器									
MAX877/878/879	1 to 6.2	5(3.3 or 3)/adj.	0.310(0.220)	240	PFM	Yes	C,E,M	当输入高于或低于输出时给出稳压的输出, 无变压器	2.95
升压开关型稳压器									
MAX608	2 to 16.5	5 or adj.	0.1(0.085)	1A	PFM	Yes	C,E	与MAX1771相同, 但接受低输入电压	1.89
MAX731	1.8 to 5.25	5	4(2)	200	PWM	Yes	C,E,M		2.60
MAX734	1.9 to 12	12	2.5(1.2)	120	PWM	Yes	C,E,M	12V快擦存储器, 热插入	2.23
MAX752	1.8 to 16	Adj.	3(1.7)	2.4W	PWM	Yes	C,E,M		2.94
MAX756/757	1.1 to 5.5	(3.3 or 5)/adj.	0.060(0.045)	250	PFM	Yes	C,E	低静态电流(I _Q)和86%高效率的最佳组合	1.95
MAX761/762	2 to 16.5	12/15 or adj. to 16.5	0.1(0.080)	120	PFM	Yes	C,E,M	12V快擦存储器, 最低I _Q , 1.8V/3V/5V输入	2.23
MAX770/771/772	2 to 16.5	5/12/15 or adj.	0.1(0.085)	1A	PFM	Yes	C,E,M	控制器, 在宽的I _{OUT} 范围内高效率	1.80
MAX1771	2 to 16.5	12 or adj.	0.1(0.085)	1A	PFM	Yes	C,E,M	与MAX771相同, 具有100mV电流检测限制	1.80
MAX777/778/779	1 to 6	5(3 or 3.3)/adj.	0.310(0.220)	300	PFM	Yes	C,E,M	片内有源二极管, 关闭时真正关断	2.65
MAX848/849	0.8 to 5.5	3.3 or adj.	150μW	250/150	PWM	Yes	C,E	包括用于D/ECT电话的带有串行I/O的2通道A/D转换器	††
MAX856/857	0.8 to 6	(3.3 or 5)/adj.	0.060(0.025)	100	PFM	Yes	C,E	低I _Q 与85%高效率的最小, 最好组合	1.72
MAX858/859	0.8 to 6	(3.3 or 5)/adj.	0.060(0.025)	25	PFM	Yes	C,E	低I _Q 与高效率的最小, 最好组合	1.72
MAX866/867	0.9 to 3	3.3 or 5/adj.	0.6(0.025)	20	PFM	Yes	E	保证0.9V启动, 低I _Q	1.76
降压开关型稳压器									
MAX640/653	4 to 11.5	3.3/3 or adj.	0.02(0.01)	225	PFM	Yes	C,E,M	超低I _Q	2.96
MAX1651	4 to 16.5	3.3 or adj.	0.1(0.080)	2A	PFM	Yes	C,E,M	驱动外部P沟道FET、低I _Q 、96.5%占空比, 单100mV电流检测限制	1.60
MAX1626/1627	3 to 16.5	3.3 or 5/adj.	0.080(0.060)	2A	PFM	Yes	I,E	与MAX1651相同, 但具有100%占空比, 高效率控制器	††
MAX746	4 to 15	5/adj.	1	2.5A	PWM	—	C,E,M	最低价格的5V至3.3V应用, 驱动外部N沟道FET	2.25
MAX747	4 to 15	5/adj.	1.3(0.8)	2.5A	PWM	Yes	C,E,M	最低价格的5V至3.3V应用, 驱动外部P沟道FET	2.25
MAX748A	3.3 to 16	3.3	3(1.7)	750	PWM	Yes	C,E,M	无副谐波开关噪声	2.60
MAX763A	3.3 to 11	3.3	2.5(1.4)	500	PWM	Yes	C,E,M	无副谐波开关噪声	2.15
MAX767	4.5 to 5.5	3.3, 3.45(R), or 3.6(S)	0.75	1.5A to 10A	PWM	Yes	C,E	专用的5V至3.3V, 高效率, 小尺寸	3.40
MAX796/797/799	4.5 to 30	5.05/3.3/2.9/adj.	1(0.7)	50W	PWM	Yes	C,E,M	同步整流器, 次级输出稳压器, 在全I _{OUT} 范围内高效率	3.65
反相型开关稳压器									
MAX764/765/766	3 to 16.5	-5/-12/-15 or adj. to 21Δ	0.1	200	PFM	Yes	C,E,M	最低I _Q	2.38
MAX774/775/776	3 to 16.5	-5/-12/-15 or adj.	0.1	1A	PFM	Yes	C,E,M	控制器, 在宽的I _{OUT} 范围内高效率	2.20
稳压的充电泵变换器									
MAX619	2 to 3.6	5	0.15	60	—	Yes	C,E,M	无电感, 备用电池	1.60
器件号									
MAX603/604	2.8 to 11.5	5/3.3 or adj.	0.32 at 500mA (MAX603) 0.48 at 400mA (MAX604)	±5	I _Q (μA), 最大(典型)*	Yes	C,E,M	无电感, 备用电池	1.85
MAX882/883/884	2.8 to 11.5	3.3/5/3.3 or adj.	0.25 at 200mA (MAX882/884) 0.25 at 250mA (MAX883)	±5	35(15) 15(10)	Yes	C,E,M	8 DIP, 8 SO (P _{DISS} = 1.9W) 8 DIP, 8 SO (P _{DISS} = 1.4W)	1.45

* 封装选项: DIP= 双列直插式封装, SO= 小型封装 (N=窄, W=宽), SSOP= 窄边的小型封装。
 ** 温度范围: C=0°C至+70°C, E=-40°C至+85°C, M=-55°C至+125°C。
 †† 提供的价格仅供参考, 且美国以外地区, 因邮费和关税, 因此价格可能有所不同。



5V/3.3V/3V/Adjustable-Output, Step-Up/Step-Down DC-DC Converters

General Description

The MAX877/MAX878/MAX879 are pulse-skipping, step-up/step-down DC-DC converters that provide a regulated output from inputs both above and below the output. They require only three external components—an inductor (typically 22 μ H) and two filter capacitors.

The MAX877 delivers a regulated 5V output from 2.5V to 6.2V inputs. The MAX878 generates pin-selectable voltages of 3.0V or 3.3V from 1.5V to 6.2V inputs. The MAX879 output can be adjusted from 2.5V to 6V via an external resistor divider from 2.5V to 6V inputs.

A unique high-power, internal, synchronous rectifier design (Active Rectifier™) enables the devices to regulate in a switched linear mode if the input voltage is higher than the desired output voltage. When the input voltage falls below the output voltage, the MAX877/MAX878/MAX879 will smoothly switch into a pulse-skipping boost mode and step up from input voltages as low as 1V. In shutdown, the active rectifier disconnects the output from the source. This stops the current drain from input to output associated with conventional step-up converters.

High-frequency operation (up to 300kHz) allows the use of small surface-mount inductors. Supply current is 195 μ A under no load, and only 20 μ A in shutdown mode. For 1-cell (1V) step-up converters with similar performance and the same pinout, refer to the MAX777/MAX778/MAX779 data sheet.

Applications

Two or Three NiCd Cells to 3V/3.3V Conversion
Three or Four Alkaline Cells to 5V Conversion
One Lithium Cell to 3V/3.3V Conversion
Pagers
Palmtop and Notebook Computers
Battery-Powered and Hand-Held Instruments

Pin Configuration

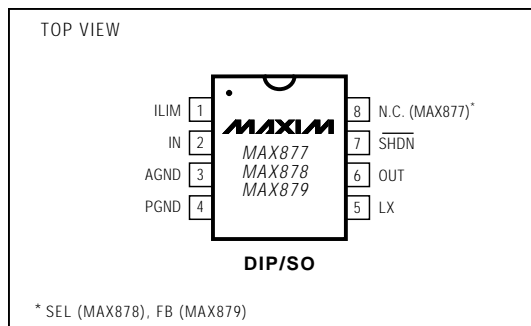

™ Active Rectifier is a trademark of Maxim Integrated Products.

Features

- ◆ Regulates from Inputs Above & Below the Output
- ◆ 1V to 6.2V Supply-Voltage Range
- ◆ Internal 1A Active Rectifier with Input-to-Output Disconnect in Shutdown
- ◆ Up to 210mA Load Currents, Guaranteed
- ◆ 85% Efficiency
- ◆ Only 3 External Components
- ◆ Adjustable Current Limit
- ◆ 195 μ A Quiescent Supply Current
- ◆ 20 μ A Shutdown Supply Current
- ◆ 3V/3.3V/5V and Adjustable Output Voltage Versions
- ◆ Available in 8-Pin DIP and SO Packages

Ordering Information

PART	TEMP. RANGE	PIN-PACKAGE
MAX877CPA	0°C to +70°C	8 Plastic DIP
MAX877CSA	0°C to +70°C	8 SO
MAX877C/D	0°C to +70°C	Dice*
MAX877EPA	-40°C to +85°C	8 Plastic DIP
MAX877ESA	-40°C to +85°C	8 SO
MAX877MJA	-55°C to +125°C	8 CERDIP

Ordering Information continued on last page.

* Contact factory for dice specifications.

Typical Operating Circuit

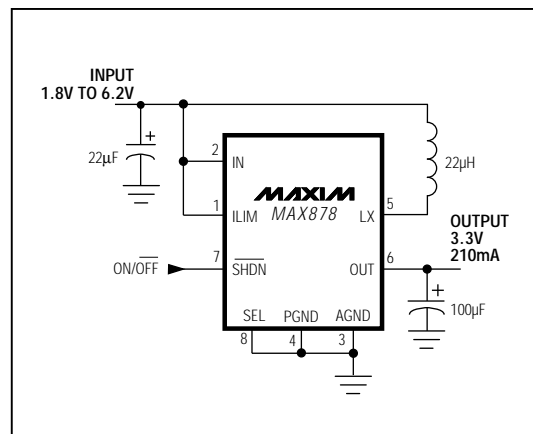

MAX877/MAX878/MAX879

5V/3.3V/3V/Adjustable-Output, Step-Up/Step-Down DC-DC Converters

ABSOLUTE MAXIMUM RATINGS

Supply Voltage (IN to PGND)	0V to +7V
Output Short-Circuit Duration to PGND, AGND (Note 1).....	30sec
Voltage Applied to:	
LX (switch off).....	-0.3V to +7V
(switch on).....	30sec short to IN or OUT
OUT, SHDN.....	-0.3V to +7V
FB	-0.3V to (OUT + 0.3V)
AGND to PGND	-0.3V, +0.3V
Reverse Battery Current.....	900mA

Continuous Power Dissipation (T _A = +70°C)	
Plastic DIP (derate 9.09mW/°C above +70°C)	727mW
SO (derate 5.88mW/°C above +70°C)	471mW
CERDIP (derate 8.00mW/°C above +70°C)	640mW
Operating Temperature Ranges:	
MAX87_C_A	0°C to +70°C
MAX87_E_A	-40°C to +85°C
MAX87_MJA	-55°C to +125°C
Storage Temperature Range	-65°C to +150°C
Lead Temperature (soldering, 10sec)	+300°C

Note 1: The output may be shorted to ground continuously if the package power dissipation is not exceeded.

Stresses beyond those listed under "Absolute Maximum Ratings" may cause permanent damage to the device. These are stress ratings only, and functional operation of the device at these or any other conditions beyond those indicated in the operational sections of the specifications is not implied. Exposure to absolute maximum rating conditions for extended periods may affect device reliability.

ELECTRICAL CHARACTERISTICS

(V_{IN} = 2.7V, I_{LOAD} = 0mA, LX = 22μH, C_{OUT} = 100μF, SHDN and ILIM connected to IN, AGND connected to PGND, T_A = T_{MIN} to T_{MAX}, typical values are at T_A = +25°C, unless otherwise noted.)

PARAMETER		CONDITIONS	MIN	TYP	MAX	UNITS	
Minimum Start-Up Voltage (Notes 2, 6)		I _{LOAD} = 0mA, T _A = +25°C		1		V	
		MAX877/MAX879 (V _{OUT} = 5V), 0mA < I _{LOAD} < 180mA, T _A = +25°C			2.5		
		MAX878/MAX879 (V _{OUT} = 3.3V), 0mA < I _{LOAD} < 120mA, T _A = +25°C			1.5		
Maximum Operating Voltage		(Notes 2, 3)	6.2			V	
Output Voltage (MAX879 set to 5V) (Note 3)		MAX877C/MAX879C: 0mA ≤ I _{LOAD} ≤ 240mA, 2.7V ≤ V _{IN} ≤ 6.2V; MAX877E/MAX879E: 0mA ≤ I _{LOAD} ≤ 220mA, 2.7V ≤ V _{IN} ≤ 6.2V; MAX877M/MAX879M: 0mA ≤ I _{LOAD} ≤ 180mA, 2.7V ≤ V _{IN} ≤ 6.2V	4.80	5.00	5.20		V
Output Voltage (MAX879 set to 3.3V) (Note 3)	SEL = 0V	MAX878C/MAX879C: 0mA ≤ I _{LOAD} ≤ 210mA, 1.8V ≤ V _{IN} ≤ 6.2V; MAX878E/MAX879E: 0mA ≤ I _{LOAD} ≤ 200mA, 1.8V ≤ V _{IN} ≤ 6.2V; MAX878M/MAX879M: 0mA ≤ I _{LOAD} ≤ 180mA, 1.8V ≤ V _{IN} ≤ 6.2V	3.17	3.30	3.43	V	
	SEL = Open	MAX878C: 0mA ≤ I _{LOAD} ≤ 210mA, 1.8V ≤ V _{IN} ≤ 6.2V; MAX878E: 0mA ≤ I _{LOAD} ≤ 200mA, 1.8V ≤ V _{IN} ≤ 6.2V; MAX878M: 0mA ≤ I _{LOAD} ≤ 180mA, 1.8V ≤ V _{IN} ≤ 6.2V	2.88	3.00	3.12		
Output Voltage Range		MAX879, I _{LOAD} = 0mA (Note 4)	2.5		6.0	V	
Efficiency		MAX877/MAX879 (V _{OUT} = 5V), I _{LOAD} = 100mA, V _{IN} = 4V		85		%	
		MAX878/MAX879 (V _{OUT} = 3.3V), I _{LOAD} = 100mA, V _{IN} = 2.5V		82			
No-Load Supply Current		I _{LOAD} = 0mA (switch off)		195	310	μA	
Shutdown Supply Current		SHDN = 0V	MAX87_C, MAX87_E		20	30	μA
			MAX87_M		20	35	
SHDN Bias Current		0V < SHDN < V _{IN}		15	100	nA	
		V _{IN} < SHDN < 5V		12	40	μA	

5V/3.3V/3V/Adjustable-Output, Step-Up/Step-Down DC-DC Converters

ELECTRICAL CHARACTERISTICS (continued)

($V_{IN} = 2.7V$, $I_{LOAD} = 0mA$, $LX = 22\mu H$, $C_{OUT} = 100\mu F$, \overline{SHDN} and $ILIM$ connected to IN , $AGND$ connected to $PGND$, $T_A = T_{MIN}$ to T_{MAX} , typical values are at $T_A = +25^\circ C$, unless otherwise noted.)

PARAMETER	CONDITIONS	MIN	TYP	MAX	UNITS
\overline{SHDN} Threshold	$V_{IN} = 1V$ to $6.2V$	$V_{IN}/2 + 0.25$			V
	$V_{IN} = 2.7V$	1.3		1.7	
\overline{SHDN} Enable Delay			150		μs
Current Limit			1.0		A
Current-Limit Temperature Coefficient			-0.3		%/ $^\circ C$
Switch Saturation Voltage	$I_{SW} = 400mA$		0.275		V
	$I_{SW} = 600mA$		0.33		
	$I_{SW} = 1000mA$		0.50		
Maximum Switch On Time	$V_{IN} = 2.5V$		4.0		μs
	$V_{IN} = 1.8V$		5.9		
	$V_{IN} = 1V$		12.6		
Minimum Switch Off Time	MAX877/MAX879		1.3		μs
	MAX878		2.3		
Rectifier Forward Voltage Drop	$I_{SW} = 400mA$		0.21		V
	$I_{SW} = 600mA$		0.31		
	$I_{SW} = 1000mA$		0.50		
Error-Comparator Trip Point (V_{REF})	MAX879, $V_{IN} = 1.8V$ to $5V$ (Note 5)	197.5	202.5	207.5	mV
FB Pin Bias Current	MAX879		10	40	nA
Switch Off Leakage Current			0.1		μA
Rectifier Off Leakage Current			0.1		μA

Note 2: Output in regulation, $V_{OUT} = V_{OUT}(\text{nominal}) \pm 4\%$.

Note 3: At high V_{IN} to V_{OUT} differentials, the maximum load current is limited by the maximum allowable power dissipation in the package (see *Absolute Maximum Ratings* and Maximum Output Current graphs in the *Typical Operating Characteristics*).

Note 4: Minimum value is production tested. Maximum value is guaranteed by design and is not production tested.

Note 5: V_{OUT} is set to a target value of $5V$ by 0.1% external feedback resistors. V_{OUT} is measured to be within $5V \pm 2.5\%$ to guarantee error-comparator trip point.

Note 6: Startup guaranteed under these load conditions.

MAX877/MAX878/MAX879

5V/3.3V/3V/Adjustable-Output, Step-Up/Step-Down DC-DC Converters

Typical Operating Characteristics

(Circuit of Figure 4, $T_A = +25^\circ\text{C}$, unless otherwise noted.)

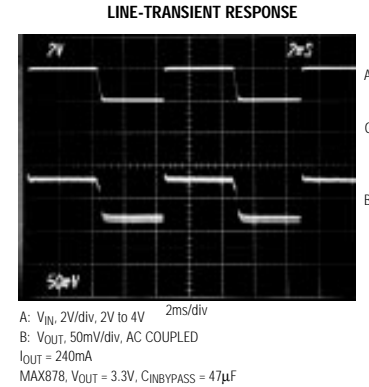
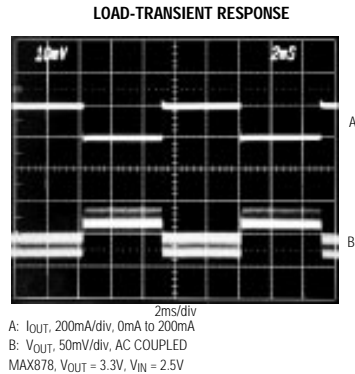
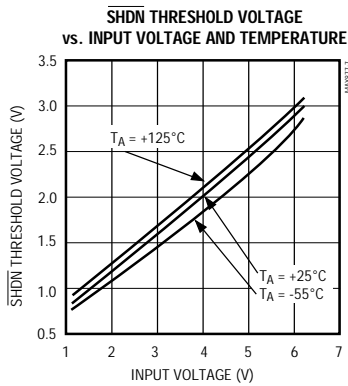
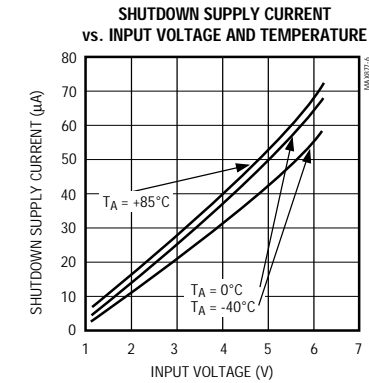
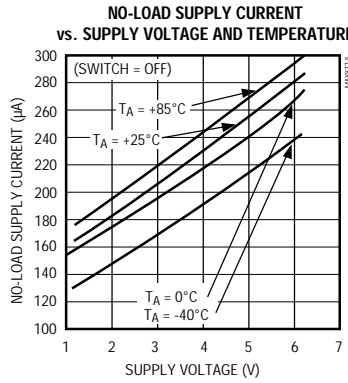
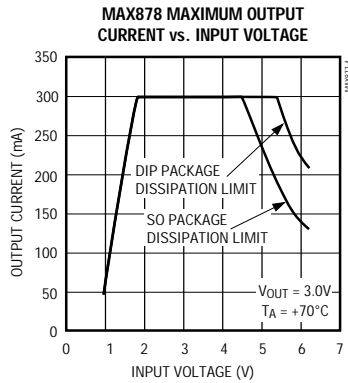
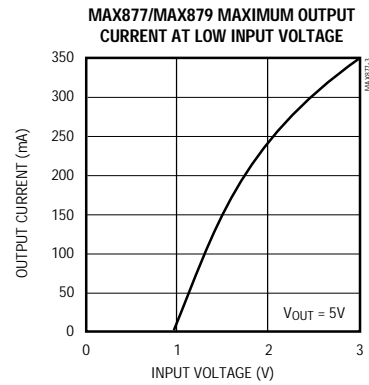
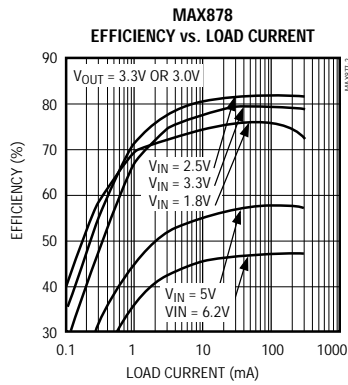
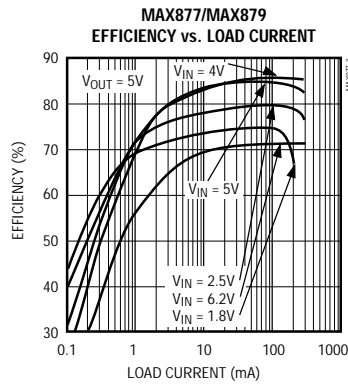

5V/3.3V/3V/Adjustable-Output, Step-Up/Step-Down DC-DC Converters

Typical Operating Characteristics (continued)

(Circuit of Figure 4, $T_A = +25^\circ\text{C}$, unless otherwise noted.)

MAX877/MAX878/MAX879

**SWITCHING WAVEFORMS—
CONTINUOUS CONDUCTION**

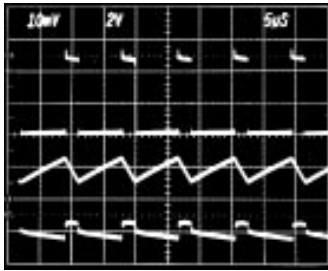

A: SWITCH VOLTAGE (LX PIN), 2V/div
B: INDUCTOR CURRENT, 0.5A/div
C: OUTPUT VOLTAGE RIPPLE, 50mV/div
MAX877, $V_{IN} = 1.5\text{V}$, $I_{OUT} = 100\text{mA}$

**SWITCHING WAVEFORMS—
DISCONTINUOUS CONDUCTION**

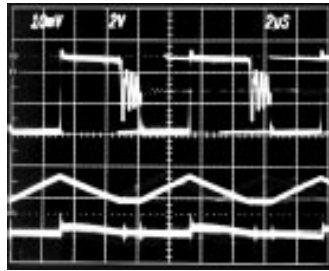

A: SWITCH VOLTAGE (LX PIN), 2V/div
B: INDUCTOR CURRENT, 0.5A/div
C: OUTPUT VOLTAGE RIPPLE, 50mV/div
MAX877, $V_{IN} = 3\text{V}$, $I_{OUT} = 70\text{mA}$

STEP-DOWN CONVERSION

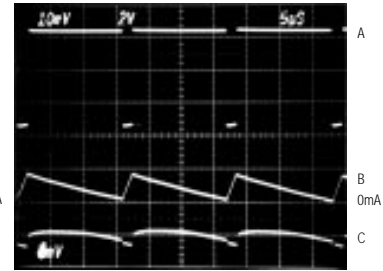

A: SWITCH VOLTAGE (LX PIN), 2V/div
B: INDUCTOR CURRENT, 0.5A/div
C: OUTPUT VOLTAGE RIPPLE, 50mV/div
MAX878, $V_{IN} = 6.0\text{V}$, $V_{OUT} = 5.0\text{V}$, $I_{OUT} = 210\text{mA}$

**STEP-UP/STEP-DOWN
OPERATION**

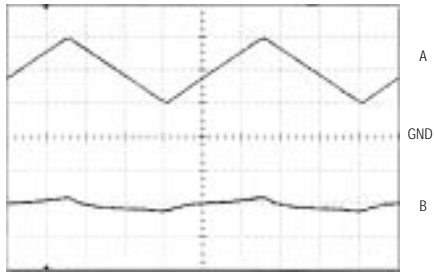

A: INPUT VOLTAGE, 2V/div, 2V to 6V
B: OUTPUT VOLTAGE, 50mV/div
MAX878, $I_{OUT} = 100\text{mA}$, $V_{OUT} = 3.3\text{V}$

**MAX878
START-UP TIME**

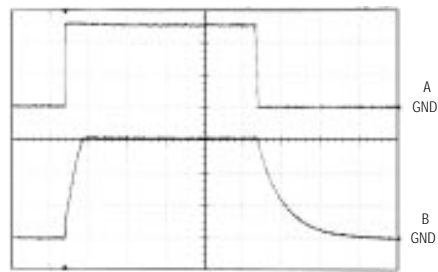

A: SHDN, 2V/div
B: V_{OUT} , 1V/div
 $V_{OUT} = 3\text{V}$

5V/3.3V/3V/Adjustable-Output, Step-Up/Step-Down DC-DC Converters

Pin Description

PIN	NAME	FUNCTION
1	ILIM	Sets switch current-limit input. Connect to IN for 1A current limit. A resistor from ILIM to IN sets lower peak inductor currents.
2	IN	Input supply.
3	AGND	Analog ground. Not internally connected to PGND.
4	PGND	Power ground must be low impedance: solder directly to ground plane or star ground. Connect to AGND, close to the device.
5	LX	1A NPN power switch collector and active-rectifier PNP emitter.
6	OUT	Voltage output. Connect filter capacitor close to pin.
7	$\overline{\text{SHDN}}$	Shutdown input disables power supply when low. Also disconnects load from input. Threshold is set at $V_{\text{IN}}/2$. Connect to IN for normal operation.
8	N.C. (MAX877)	No connect, not internally connected.
	SEL (MAX878)	Selects the main output voltage: 3.3V when connected to AGND, 3.0V when left open.
	FB (MAX879)	Feedback input for adjustable-output operation. Connect to an external voltage divider between V_{OUT} and AGND.

Detailed Description

Operating Principle

The MAX877/MAX878/MAX879 combine a switch-mode regulator with an NPN bipolar power switch and current limit, a precision voltage reference, and a synchronous rectifier—all in a single monolithic device. In shutdown mode, the internal rectifier is completely turned off and disconnects the load from the source. Only two external components are required in addition to the input bypass capacitor—a 22 μH inductor, and a 100 μF filter capacitor.

A minimum-off-time, current-limited, pulse-frequency-modulation (PFM) control scheme combines the high output power and efficiency of pulse-width modulation (PWM) with the low quiescent currents of traditional PFM pulse skippers.

External conditions (inductor value, load, and input voltage) determine the way the converter operates, as follows:

At light loads, the current through the inductor starts at zero, rises to a peak value, and drops down to zero in each cycle (discontinuous-conduction mode). In this case, the switching frequency is governed by a pair of one-shots, which set a maximum on-time inversely pro-

portional to V_{IN} [$t_{\text{ON}} = 8.8/(V_{\text{IN}} - 0.25)$] and a minimum off-time (1.3 μs for MAX877/MAX879, or 2.3 μs for MAX878). With a 22 μH inductor, LX's peak current is about 400mA and is independent of input voltage. Efficiency at light loads is improved because of lower peak currents.

At very light loads, more energy is stored in the coil than is required by the load in each cycle. The converter regulates by skipping entire cycles. Efficiency is typically 65% to 75% in the pulse-skipping mode. Pulse-skipping waveforms can be irregular, and the output waveform contains a low-frequency component. Larger, low equivalent-series-resistance (ESR) filter capacitors can help reduce the ripple voltage if needed.

At heavy loads above approximately 100mA, the converter enters continuous-conduction mode, where current always flows in the inductor. The switch ON state is controlled on a cycle-by-cycle basis, either by the $t_{\text{ON(max)}}$ time or the preset current limit in the switch. This prevents exceeding the switch current rating or saturating the inductor. At very heavy loads, the inductor current self-oscillates between this peak current limit and some lower value governed by the minimum off-time, the inductance value, and the input/output differential.

5V/3.3V/3V/Adjustable-Output, Step-Up/Step-Down DC-DC Converters

MAX877/MAX878/MAX879

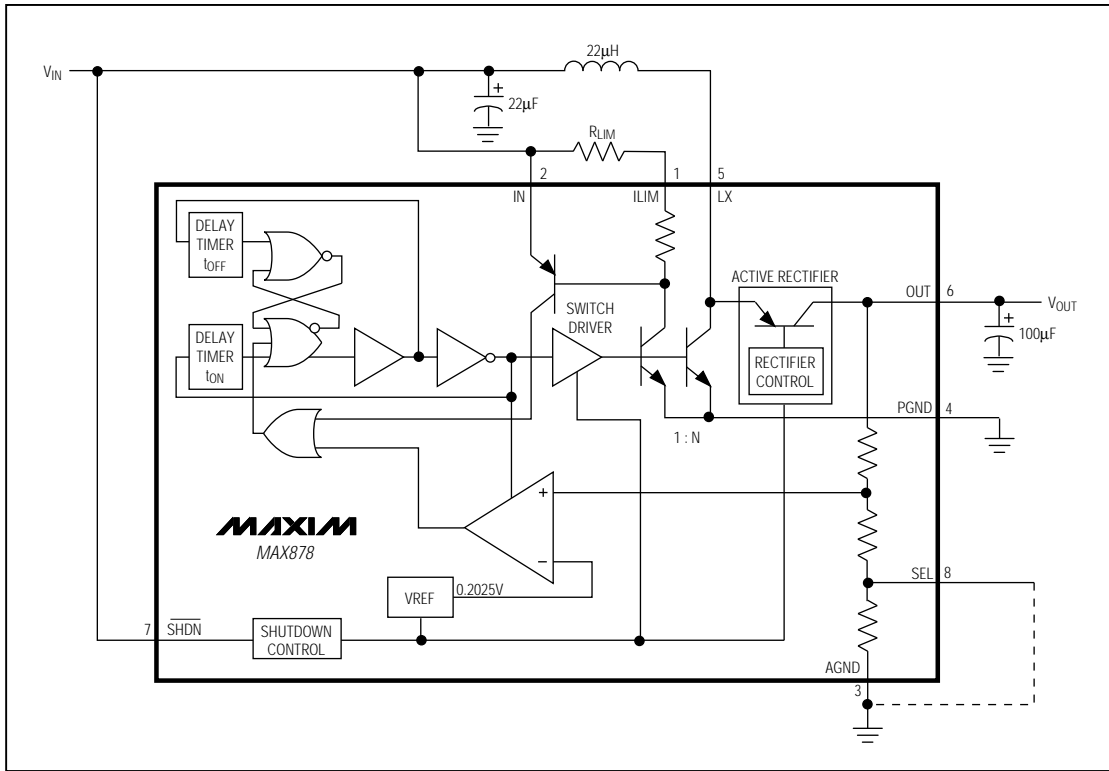

Figure 1. MAX878 Block Diagram

With ILIM shorted to IN, the peak switch current of the internal NPN power switch is set to 1A. It can be set to a lower value by connecting a resistor between ILIM and IN (see *Current Limit* section). This enables the use of physically smaller inductors with lower saturation-current ratings. At 1A, the switch voltage drop (V_{SW}) is about 500mV. V_{SW} decreases to about 250mV at 0.1A. Conventional PWM converters generate constant-frequency switching noise, while this architecture produces variable-frequency switching noise. The output ripple is the product of the peak inductor current and the output capacitor's ESR. Unlike conventional pulse-skippers, the MAX877/MAX878/MAX879 peak currents are scaled down at light loads, resulting in lower output ripple.

Step-Down Mode and Power Dissipation
In battery-powered applications, for example, where the input voltage exceeds the output voltage, the MAX877/MAX878/MAX879 behave as "switched" linear regulators. If the output voltage starts to drop, the switch turns on and energy is stored in the coil, as in normal step-up mode. After the switch turns off, the voltage at LX flies high. The active rectifier turns on when LX rises above V_{IN} . As in a linear regulator, the voltage difference between V_{IN} and V_{OUT} appears across the rectifier (actually a PNP transistor) until the current goes to zero and the rectifier turns off. At high V_{IN} to V_{OUT} differentials, the maximum load current is limited by the maximum allowable power dissipation in the package (see *Typical Operating Characteristics*).

5V/3.3V/3V/Adjustable-Output, Step-Up/Step-Down DC-DC Converters

Active Rectifier

The internal active rectifier of the MAX877/MAX878/MAX879 replaces the external Schottky catch diode in normal boost operation. The rectifier consists of a PNP pass transistor and a unique control circuit which, in shutdown mode, entirely disconnects the load from the source. This is a distinct advantage over standard boost topologies, since it prevents battery drain in shutdown. The MAX877/MAX878/MAX879 can withstand a momentary short at the output in normal operation.

The active rectifier also acts as a zero-dropout regulator if the input exceeds the regulated output. The device still switches to deliver power to the output, and the difference between the input and output voltage appears across the rectifier. Efficiency is similar to that of a linear regulator if the MAX877/MAX878/MAX879 are used as step-down converters. The maximum output current ($I_{OUT(MAX)}$) with larger input/output differentials is determined by package power dissipation. $I_{OUT(MAX)}$ can be approximated by:

$$I_{OUT(MAX)} \approx \left(\frac{P_{DISS}}{V_{IN} - V_{OUT}} \right) \times 0.9$$

Shutdown

Shutdown (\overline{SHDN}) is a high-impedance, active-low input. Connect it to IN for normal operation. Keeping \overline{SHDN} at ground holds the converters in shutdown mode. Since the active rectifier is turned off in this mode, the path from input to load is cut, and the output effectively drops to 0V. The supply current in shutdown mode ranges from 4 μ A at $V_{IN} = 1V$ to 50 μ A at $V_{IN} = 5V$. The shutdown-circuit threshold is set nominally to $V_{IN}/2 + 250mV$. When \overline{SHDN} is below this threshold, the device is shut down; it is enabled with \overline{SHDN} above the threshold. When driven from external logic, \overline{SHDN} can be driven to a higher voltage than V_{IN} , (6.2V max).

Current Limit

Connecting ILIM to IN sets an LX current limit of 1A. For smaller output power levels that do not require the maximum peak current, reduce the peak inductor current by connecting a resistor between ILIM and IN. This optimizes overall efficiency and allows very small, low-cost coils with lower current ratings. See Figure 2 to select the resistor (see also *Inductor Selection* section).

Output Voltage Selection

The MAX877's output voltage is fixed at 5V. The MAX878's output voltage can be set to 3V by leaving the SEL pin open, or to 3.3V by connecting SEL to AGND.

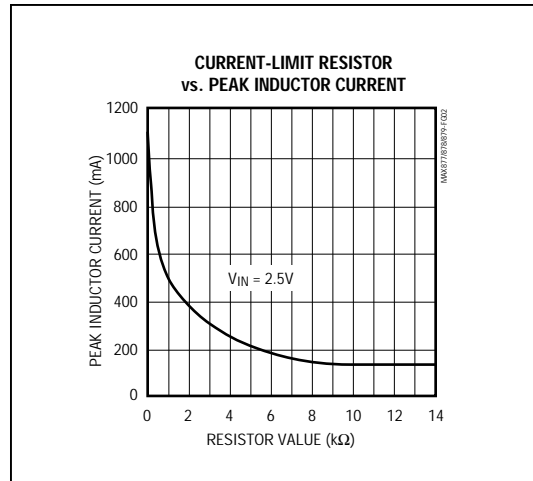

Figure 2. Current-Limit Resistor vs. Peak Inductor Current

The MAX879's output voltage is set by two resistors, R1 and R2 (Figure 3), which form a voltage divider between the output and the FB pin. The output voltage can be set from 2.5V to 6.0V by the equation:

$$V_{OUT} = V_{REF} \frac{R1 + R2}{R2}$$

where $V_{REF} = 0.2025V$.

To simplify the resistor selection:

$$R1 = R2 \left(\frac{V_{OUT}}{V_{REF}} - 1 \right)$$

Since the input current at FB has a maximum of 40nA, large values (10k Ω to 50k Ω for R2) can be used without significant accuracy loss. For 1% error, the current through R2 should be at least 100 times FB's bias current.

When large values are used for the feedback resistors ($R1 > 50k\Omega$), stray output impedance at FB can add a "lag" to the feedback response, destabilizing the regulator and creating a larger ripple at the output. Lead lengths and circuit board traces at the FB node should be kept short. Reduce ripple by adding a "lead" compensation capacitor (C3, 100pF to 50nF) in parallel with R1.

5V/3.3V/3V/Adjustable-Output, Step-Up/Step-Down DC-DC Converters

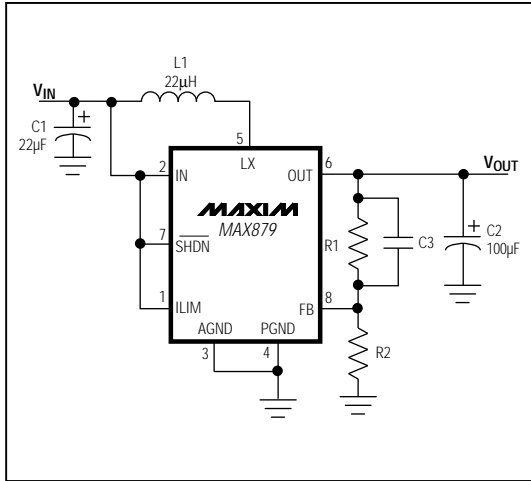

Figure 3. MAX879 Adjustable Voltage

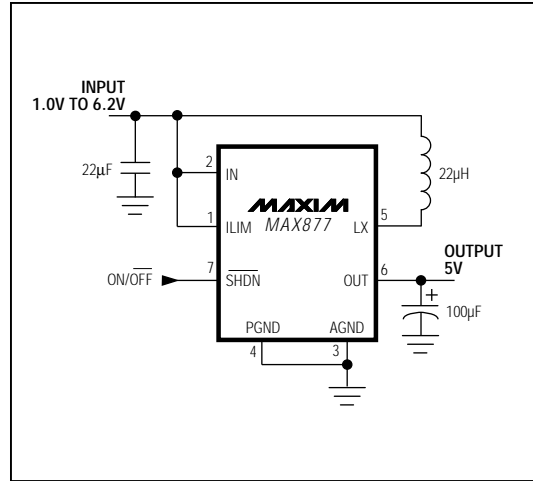

Figure 4. MAX877 Standard Application Circuit

MAX877/MAX878/MAX879

Applications Information

Figure 4 shows a MAX877 step-up application circuit. This circuit starts up and operates with inputs ranging from 1.0V to 6.2V. Start-up time is a function of the load, typically less than 5ms. Output current capability is a function of the input voltage (see *Typical Operating Characteristics*).

The converters will regulate down to the output voltage and seamlessly switch into boost mode as the input drops below the output voltage. This is especially useful in battery-powered applications, where the battery voltage may initially exceed the output voltage. To generate 5V from four alkaline cells in series, the input ranges from 6.2V to 3.6V. When the battery pack is fresh, the MAX877 will step down with the active rectifier acting as the switch. As the batteries approach 5V, or the desired output voltage, the converter's control circuitry will ensure a smooth transition into step-up mode. The converter operates until the batteries are less than 3V; efficiency is typically 80% with fresh batteries, and is close to 85% at $V_{IN} = 4V$.

Inductor Selection

The 22µH inductor shown in the *Typical Operating Circuit* is sufficient for most MAX877/MAX878/MAX879 designs. Other inductor values ranging from 10µH to 47µH are also suitable. The inductor should have a saturation rating equal to or greater than the peak switch-

current limit, which is 1A without an external current limit (ILIM connected to IN). It is acceptable to operate the inductor at 120% of its saturation rating; however, this may slightly reduce efficiency. For highest efficiency, use an inductor with a low **DC resistance**, preferably under 0.2Ω. Table 1 lists suggested inductor suppliers.

Capacitor Selection

The 100µF, 10V surface-mount tantalum (SMT) output capacitor shown in the *Typical Operating Circuit* will provide a 25mV output ripple or less, stepping up from 3V to 5V at 200mA. Smaller capacitors, down to 10µF, are acceptable for light loads or in applications that can tolerate higher output ripple. The input capacitor may be omitted if the supply has low output impedance and the input lead length is less than 2 inches (5cm) or the loads are small.

The primary factor in selecting both the output and input filter capacitor is low ESR. The ESR of both bypass and filter capacitors affects efficiency. Optimize performance by increasing filter capacitors or using specialized low-ESR capacitors. The smallest low-ESR SMT tantalum capacitors currently available are Sprague 595D or 695D series. Sanyo OS-CON organic-semiconductor through-hole capacitors also exhibit very low ESR, are rated for the wide temperature range, and are especially suitable for operation at cold temperatures (below 0°C).

Table 1 lists suggested capacitor suppliers.

5V/3.3V/3V/Adjustable-Output, Step-Up/Step-Down DC-DC Converters

Layout

The MAX877/MAX878/MAX879's high peak currents and high-frequency operation make PC layout important for minimum ground bounce and noise. Locate input bypass and output filter capacitors close to the device pins. All connections to the FB pin (MAX879)

should also be kept as short as possible. A ground plane is recommended. Solder AGND (pin 3) and PGND (pin 4) directly to the ground plane. Refer to the MAX877/MAX878/MAX879 evaluation kit (EV kit) manual for a suggested surface-mount layout.

Table 1. Component Suppliers

PRODUCTION METHOD	INDUCTORS	CAPACITORS
Surface Mount	Sumida CD54-220 (22μH) Murata-Erie LQHYN1501K04M00-D5 (15μH) CoilCraft DO3316-223 (22μH) Coiltronics CTX20-1 (22μH)	Sprague 595D Sprague 695D Matsuo 267 series AVX TPS series
Miniature Through-Hole	Sumida RCH654-220 (22μH)	Sanyo OS-CON (low-ESR organic semiconductor)
Low-Cost Through-Hole	Renco RL 1284-22 (22μH) CoilCraft PCH-27-223 (22μH)	Nichicon PL series (low-ESR electrolytic) United Chemi-Con LXF series

AVX	USA:	(207) 282-5111	FAX (207) 283-1941
CoilCraft	USA:	(708) 639-6400	FAX (708) 639-1469
Coiltronics	USA:	(407) 241-7876	FAX (407) 241-9339
Matsuo	USA:	(714) 969-2491	FAX (714) 960-6492
	Japan:	(06) 332-0871	
Murata-Erie	USA:	(800) 831-9172	FAX (814) 238-0490
Nichicon	USA:	(708) 843-7500	FAX (708) 843-2798
	Japan:	(81) 7-5231-8461	FAX (81) 7-5256-4158
Renco	USA:	(516) 586-5566	FAX (516) 586-5562
Sanyo	USA:	(619) 661-6835	FAX (619) 661-1055
	Japan:	(0720) 70-1005	FAX (0720) 70-1174
Sprague	USA:	(603) 224-1961	FAX (603) 224-1430
Sumida	USA:	(708) 956-0666	FAX (708) 956-0702
	Japan:	(81) 3607-5111	FAX (81) 2070-1174
United Chemi-Con	USA:	(714) 255-9500	FAX (714) 255-9400

5V/3.3V/3V/Adjustable-Output, Step-Up/Step-Down DC-DC Converters

Ordering Information (continued)

PART	TEMP. RANGE	PIN-PACKAGE
MAX878 CPA	0°C to +70°C	8 Plastic DIP
MAX878CSA	0°C to +70°C	8 SO
MAX878C/D	0°C to +70°C	Dice*
MAX878EPA	-40°C to +85°C	8 Plastic DIP
MAX878ESA	-40°C to +85°C	8 SO
MAX878MJA	-55°C to +125°C	8 CERDIP
MAX879 CPA	0°C to +70°C	8 Plastic DIP
MAX879CSA	0°C to +70°C	8 SO
MAX879C/D	0°C to +70°C	Dice*
MAX879EPA	-40°C to +85°C	8 Plastic DIP
MAX879ESA	-40°C to +85°C	8 SO
MAX879MJA	-55°C to +125°C	8 CERDIP

* Contact factory for dice specifications.

Chip Topography

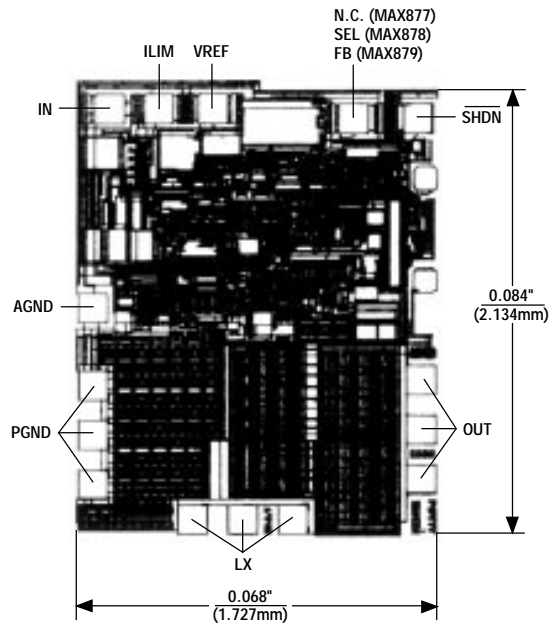

MAX877/MAX878/MAX879

TRANSISTOR COUNT: 170
SUBSTRATE CONNECTED TO AGND

5V/3.3V/3V/Adjustable-Output, Step-Up/Step-Down DC-DC Converters

Package Information

