

●应用与设计

采用 MAX6577 设计的多点测温系统

华北电力大学动力工程系 田亮 刘鑫屏 苏杰

摘要:介绍了单线输出温度传感器 MAX6577 的特性,给出了应用 MAX6577 设计多点分布式测温系统的具体方法。

关键词:MAX6577; 温度测量; 分布式

分类号:TP212.11 **文献标识码:**B **文章编号:**1006-6977(2003)05-0009-02

Adopting MAX6577 to Design Multipoint Measure Temperature System

Tian Liang Liu XinPing Su Jie

Abstract:The characteristic of the output temperature sensor - MAX6577 is introduced, and the concrete methods adopting MAX6577 to design multipoint distributed measure temperature system is given in this paper.

Key words: temperature system; MAX6577

1 MAX6577 简介

MAX6577 是 MAXIM 公司推出的低成本、低功耗新型温度传感器。其主要特点如下:

- 可实现温度/频率变换;
- 采用单引脚频率输出,只占用一个 I/O 口;
- 测温范围为 $-40 \sim +125^{\circ}\text{C}$;
- 典型误差为 $\pm 0.8^{\circ}\text{C}$,最大为 $\pm 4.5^{\circ}\text{C}$;
- 不用外接其它元件;
- 电源电压为 $2.7 \sim 5.5\text{V}$;
- 典型电源电流为 $140\mu\text{A}$;
- 采用小型 6 脚 SOT23 封装。

MAX6577 的引脚排列如图 1 所示。其中引脚 VDD 为电源输入引脚; TS1、TS0 分别为逻辑 1、0 引脚; OUT 为输出引脚; NO 为空脚。

接通电源后, MAX6577 即可处于自发工作状态,输出占空比为 1:1 的方波,但方波的频率受环境温度的调制,具体表达式为:

$$T = f/k - 273.15\text{K}$$

其中 T 为环境温度 ($^{\circ}\text{C}$); f 为输出频率 (Hz); K 为输出系数 (K/Hz); K 为开氏温度。输出系数 k 由



图 1 MAX6577 引脚图

引脚 TS1、TS0 接 VDD 或 GND 设定,具体如表 1 所列。

MAX6577 的频率输出为推挽输出,在 5V 电源情况下,该输出符合 TTL 电平标准,可直接与单片机连接,也可以在相应的电压下与低电压版本的单片机直接连接。

为了方便使用,将常用温度与输出频率之间的对应关系列于表 2。表中的 k 越大,传感器的灵敏度越高,但噪声的幅值也越大。

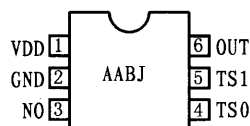
2 与 MCS-51 系列单片机的接口

2.1 单点测温

MAX6577 与 MCS-51 系列单片机的接口连接方法如图 2 所示。一般可将频率输出接到定时/计数器 I/O 口 T0 或 T1 上,这样可以在规定的时间内对

表 1 输出系数 k 的设定

TS1	TS0	k
GND	GND	4
GND	VDD	1
VDD	GND	1/4
GND	VDD	1/16

表 2 温度与输出频率的对应关系

	0°C	25°C	100°C
k = 4	1092.6	1192.6	1492.6
k = 1	273.15	298.15	373.15
k = 1/4	68.29	74.54	93.29
k = 1/16	17.07	18.63	23.32



图2 MAX6577与单片机的连接

频率脉冲进行计数,计数值即反映频率的高低,对计数值进行简单的计算可以得到需要的温度信号。为了保证测量精度,应使用频率测量法测温,且输出频率应尽量高,即k应大一些。

2.2 多点测温

因为单片机内的定时/计数器资源有限,所以采用多点切换的方法。本文以一个8路温度测量系统的设计为例来加以说明,其设计方案见图3。图中选用74LS151构成8选1开关,并将输出接到T0,由P1口的3根I/O线进行地址选择。P1.3接发光二极管,用于指示单片机系统的工作状态。X25045提供电源监控、看门狗和512字节的EEPROM,该设计由于将X25045的片选线和写保护线接到单片机的一个I/O口上,因此,只有在X25045被选中时才可以对EEPROM进行写入,从而避免了各种干扰对数据的破坏。TXD、RXD接SN75LBC184可构成RS485总线半双工通讯网络,而P3.7用于收发控制,利用SN75LBC184可以抑制由于雷击或其它原因在通讯

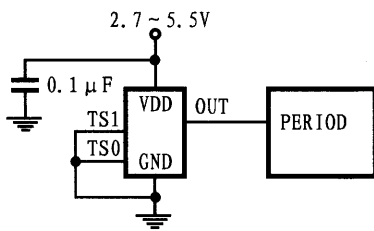

图3 多路测温示意图

线路中产生的各种瞬时过电压,从而使系统免遭损坏。

该设计是将MAX6577和一个电容焊接在很小的电路板上,并用环氧树脂和铝质外壳封装在一起构成测温探头。由于传感器输出的低频脉冲信号具有很强的抗干扰能力,故可以远距离传输。在频率信号线上接上拉电阻,可以使脉冲以电流信号方式传输,进一步提高抗干扰性,增加传输距离。但该上拉电阻不能过小,若太小,其传输电流将引起传感器自身温度的变化。

为了提高测量的分辨率和缩短每一路的测量时间,MAX6577的系数k应设置成

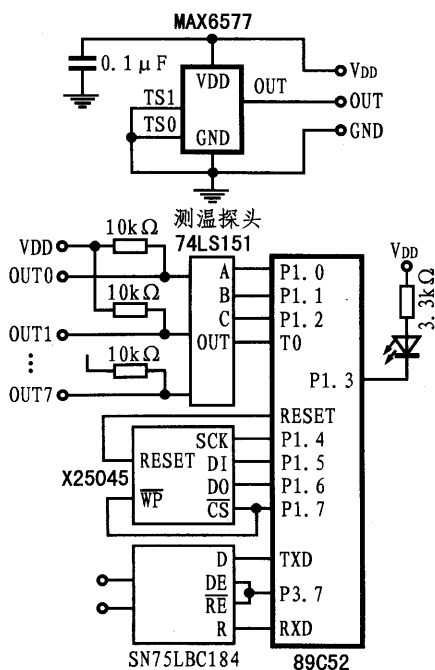
4。这样,在-25~125℃的温度范围内,频率变化范围为992.6~1592.6Hz,若对每一路脉冲信号取2秒的计数时间,则计数范围可在1985-2985之间变化,测量的分辨率可以达到0.125℃,这样系统的测温准确度只取决于传感器。

该系统选89C52单片机,并用定时/计数器T0作为脉冲计数器,T1作为定时器。T1的定时间隔为50ms,如果另设计一个以40为周期的软件计数器,则可产生2s的时间间隔。T2作为波特率发生器。

系统软件包括主程序、定时中断、通讯中断几个部分。其程序关键部分的流程框图见图4所示。

3 结束语

用MAX6577作为温度传感器可在保证测温准确度的前提下,简化设计,降低成本。该系统有着广泛的应用,如电子元件和设备的工作温度检测、智能环境温度监测、粮仓温度监测、大棚温度监测等。

参考文献

1. 孙涵芳,徐爱卿. MCS-51/95系列单片机原理与应用. 北京航空学院出版社. 1988.2
2. MAXIM. MAX6577T temperature Sensors data

enchrion 2000

收稿日期:2002-10-16

咨询编号:030503



图4 程序流程



SOT Temperature Sensors with Period/Frequency Output

MAX6576/MAX6577

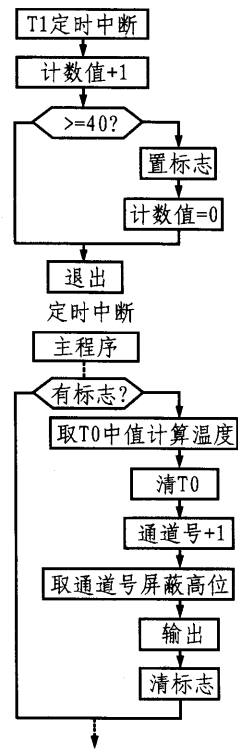
General Description

The MAX6576/MAX6577 are low-cost, low-current temperature sensors with a single-wire output. The MAX6576 converts the ambient temperature into a square wave with a period proportional to absolute temperature ($^{\circ}\text{K}$). The MAX6577 converts the ambient temperature into a square wave with a frequency proportional to absolute temperature. The MAX6576 offers accuracy of $\pm 3^{\circ}\text{C}$ at $+25^{\circ}\text{C}$, $\pm 4.5^{\circ}\text{C}$ at $+85^{\circ}\text{C}$, and $\pm 5^{\circ}\text{C}$ at $+125^{\circ}\text{C}$. The MAX6577 offers accuracy of $\pm 3^{\circ}\text{C}$ at $+25^{\circ}\text{C}$, $\pm 3.5^{\circ}\text{C}$ at $+85^{\circ}\text{C}$, and $\pm 4.5^{\circ}\text{C}$ at $+125^{\circ}\text{C}$.

Both devices feature a single-wire output that minimizes the number of pins necessary to interface with a microprocessor. The period/frequency range of the output square wave can be selected by hard-wiring the two time-select pins (TS0, TS1) to either V_{DD} or GND. The MAX6576/MAX6577 are available in space-saving 6-pin SOT23 packages.

Applications

Critical μP and μC Temperature Monitoring
 Portable Battery-Powered Equipment
 Cell Phones
 Battery Packs
 Hard Drives/Tape Drives
 Networking and Telecom Equipment
 Medical Equipment
 Automotive

Pin Configuration

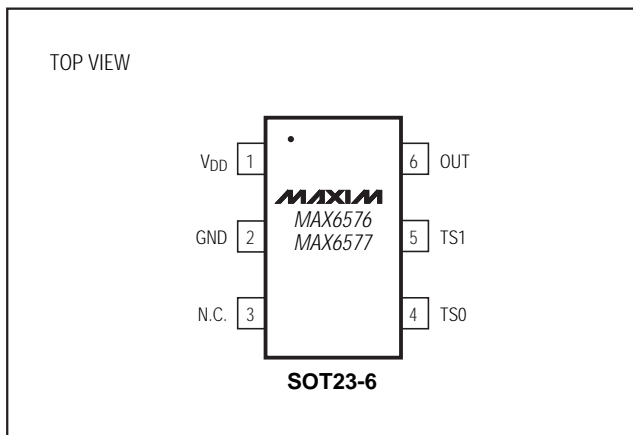

Features

- ◆ Simple Single-Wire Output
- ◆ Two Output Types Available
 - Temperature to Period (μs) (MAX6576)
 - Temperature to Frequency (Hz) (MAX6577)
- ◆ $\pm 0.8^{\circ}\text{C}$ Accuracy at $+25^{\circ}\text{C}$ ($\pm 3^{\circ}\text{C}$ max)
- ◆ No External Components
- ◆ Operates from $+2.7\text{V}$ to $+5.5\text{V}$ Supply Voltage
- ◆ Low $140\mu\text{A}$ Typical Supply Current
- ◆ Standard Operating Temperature Range: -40°C to $+125^{\circ}\text{C}$
- ◆ Small 6-Pin SOT23 Package

Ordering Information

PART	TEMP. RANGE	PIN-PACKAGE	SOT TOP MARK
MAX6576ZUT	-40°C to $+125^{\circ}\text{C}$	6 SOT23	AABI
MAX6577ZUT	-40°C to $+125^{\circ}\text{C}$	6 SOT23	AABJ

Typical Operating Circuit

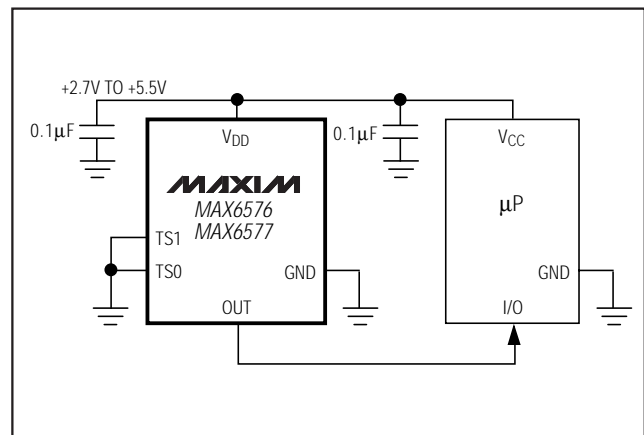

SOT Temperature Sensors with Period/Frequency Output

ABSOLUTE MAXIMUM RATINGS

Terminal Voltage (with respect to GND)

V_{DD} -0.3V to +6V

TS1, TS0, OUT-0.3V to ($V_{DD} + 0.3V$)

Input/Output Current, All Pins±20mA

Continuous Power Dissipation ($T_A = +70^\circ\text{C}$)

6-pin SOT23 (derate 7.10mW/°C above +70°C).....571mW

Operating Temperature Range-40°C to +125°C

Storage Temperature Range.....-65°C to +150°C

Lead Temperature (soldering, 10sec)+300°C

Stresses beyond those listed under "Absolute Maximum Ratings" may cause permanent damage to the device. These are stress ratings only, and functional operation of the device at these or any other conditions beyond those indicated in the operational sections of the specifications is not implied. Exposure to absolute maximum rating conditions for extended periods may affect device reliability.

ELECTRICAL CHARACTERISTICS

($V_{DD} = +2.7V$ to +5.5V, $T_A = -40^\circ\text{C}$ to +125°C, unless otherwise noted. Typical values are specified at $T_A = +25^\circ\text{C}$ and $V_{DD} = +5V$, unless otherwise noted.)

PARAMETER	SYMBOL	CONDITIONS		MIN	TYP	MAX	UNITS
V_{DD} Range	V_{DD}			2.7		5.5	V
Supply Current	I_{DD}	$V_{DD} = 5.5V$	$T_A = -40^\circ\text{C}$ to +85°C		140	250	μA
			$T_A = -40^\circ\text{C}$ to +125°C			400	
Temperature Sensor Error (Note 1)		MAX6576	$T_A = -20^\circ\text{C}$	-7.5	±1.1	+7.5	°C
			$T_A = 0^\circ\text{C}$	-5.5	±0.9	+5.5	
			$T_A = +25^\circ\text{C}$	-3.0	±0.8	+3.0	
			$T_A = +85^\circ\text{C}$	-4.5	±0.5	+4.5	
			$T_A = +125^\circ\text{C}$	-5.0	±0.5	+5.0	
		MAX6577	$T_A = -20^\circ\text{C}$	-7.5	±1.1	+7.5	°C
			$T_A = 0^\circ\text{C}$	-6.5	±0.9	+6.5	
			$T_A = +25^\circ\text{C}$	-3.0	±0.8	+3.0	
			$T_A = +85^\circ\text{C}$	-3.5	±0.5	+3.5	
			$T_A = +125^\circ\text{C}$	-4.5	±0.5	+4.5	
Output Clock Period	t_{OUT}	MAX6576, T (temp) in °K, Figure 1	$V_{TS1} = \text{GND}, V_{TS0} = \text{GND}$		10T		μs
			$V_{TS1} = \text{GND}, V_{TS0} = V_{DD}$		40T		
			$V_{TS1} = V_{DD}, V_{TS0} = \text{GND}$		160T		
			$V_{TS1} = V_{DD}, V_{TS0} = V_{DD}$		640T		
Output Clock Frequency	f_{OUT}	MAX6577, T (temp) in °K, Figure 2	$V_{TS1} = \text{GND}, V_{TS0} = \text{GND}$		4T		Hz
			$V_{TS1} = \text{GND}, V_{TS0} = V_{DD}$		1T		
			$V_{TS1} = V_{DD}, V_{TS0} = \text{GND}$		T/4		
			$V_{TS1} = V_{DD}, V_{TS0} = V_{DD}$		T/16		
OUT Duty Cycle (Note 2)					0.5		
Time-Select Pin Logic Levels	V_{IL}					0.8	V
	V_{IH}			2.3			
OUT Voltage	V_{OL}		$V_{DD} > 4.5V, I_{SINK} = 3.2\text{mA}$			0.4	V
			$V_{DD} > 2.7V, I_{SINK} = 1.2\text{mA}$			0.3	
	V_{OH}		$V_{DD} > 4.5V, I_{SRC} = 800\mu\text{A}$	$V_{DD} - 1.5$			
			$V_{DD} > 2.7V, I_{SRC} = 500\mu\text{A}$	$0.8V_{DD}$			

Note 1: See the Temperature Accuracy histograms in the *Typical Operating Characteristics*.

Note 2: The output duty cycle is guaranteed to be 50% by an internal flip-flop.

SOT Temperature Sensors with Period/Frequency Output

Typical Operating Characteristics

(V_{DD} = +5V, T_A = +25°C, unless otherwise noted.)

MAX6576/MAX6577

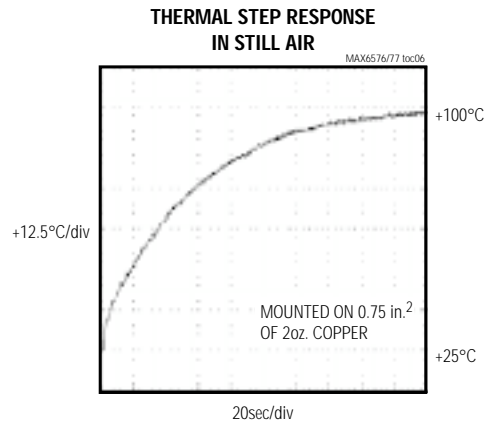
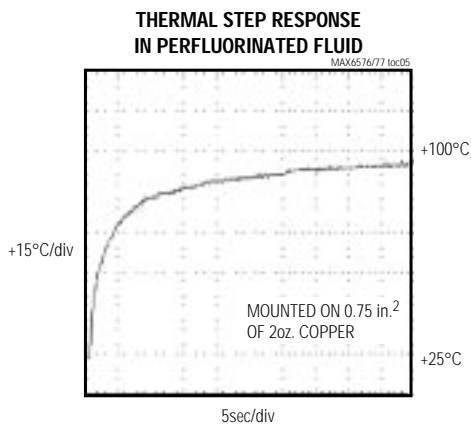
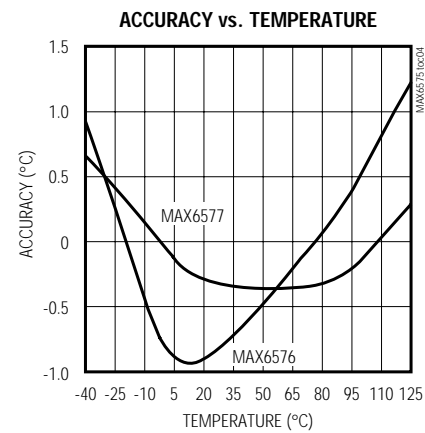
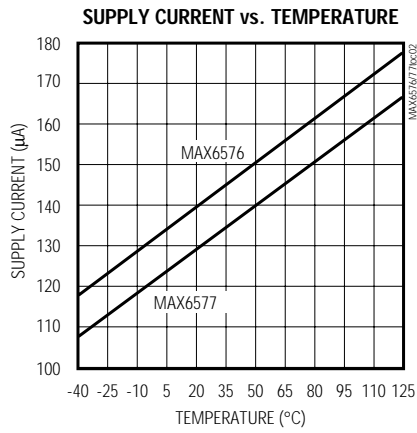
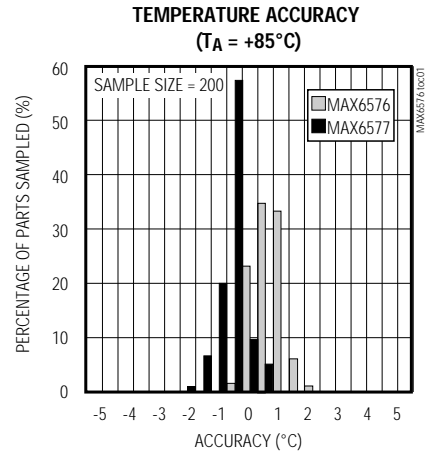
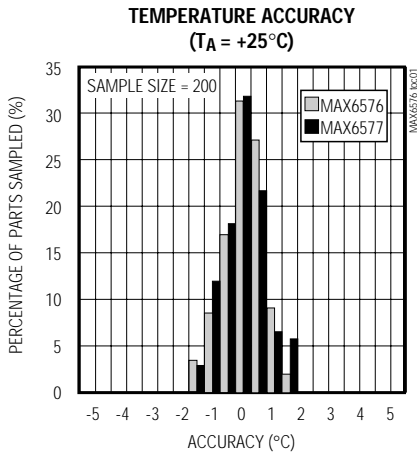

SOT Temperature Sensors with Period/Frequency Output

Pin Description

PIN	NAME	FUNCTION
1	V _{DD}	Positive Supply Voltage
2	GND	Ground
3	N.C.	No Connection. Connect pin to GND or leave open.
4, 5	TS1, TS0	Time-Select Pins. TS1 and TS0 set the temperature scale factor by connecting TS1 and TS0 to either V _{DD} or GND. See Tables 1 and 2.
6	OUT	Square-Wave Output with a Clock Period Proportional to Absolute Temperature (°K) (MAX6576)
		Square-Wave Output with a Clock Frequency Proportional to Absolute Temperature (°K) (MAX6577)

Table 1. MAX6576 Time-Select Pin Configuration

TS1	TS0	SCALAR MULTIPLIER (μs/°K)
GND	GND	10
GND	V _{DD}	40
V _{DD}	GND	160
V _{DD}	V _{DD}	640

Note: The temperature, in °C, may be calculated as follows:

$$T(^{\circ}\text{C}) = \frac{\text{period}(\mu\text{s})}{\text{scalar multiplier}(\mu\text{s}/^{\circ}\text{K})} - 273.15^{\circ}\text{K}$$

Table 2. MAX6577 Time-Select Pin Configuration

TS1	TS0	SCALAR MULTIPLIER (Hz/°K)
GND	GND	4
GND	V _{DD}	1
V _{DD}	GND	1/4
V _{DD}	V _{DD}	1/16

Note: The temperature, in °C, may be calculated as follows:

$$T(^{\circ}\text{C}) = \frac{\text{frequency}(\text{Hz})}{\text{scalar multiplier}(\text{Hz}/^{\circ}\text{K})} - 273.15^{\circ}\text{K}$$

Detailed Description

The MAX6576/MAX6577 low-cost, low-current (140μA typ) temperature sensors are ideal for interfacing with microcontrollers (μCs) or microprocessors (μPs). The MAX6576 converts ambient temperature into a 50% duty-cycle square wave with a period proportional to absolute temperature. The MAX6577 converts ambient temperature into a 50% duty-cycle square wave with a frequency proportional to absolute temperature. Time-select pins (TS1, TS0) permit the internal temperature-controlled oscillator (TCO) to be scaled by four preset multipliers. The MAX6576/MAX6577 feature a single-wire interface to minimize the number of port pins necessary for interfacing with a μP.

MAX6576 Characteristics

The MAX6576 temperature sensor converts temperature to period. The output of the device is a free-running, 50% duty-cycle square wave with a period that

is proportional to the absolute temperature (°K) of the device (Figure 1). The MAX6576 has a push/pull CMOS output with sharp edges. The speed of the output square wave can be selected by hard-wiring TS1 and TS0 as shown in Table 1. One of four scaled output periods can be selected using TS1 and TS0.

MAX6577 Characteristics

The MAX6577 temperature sensor converts temperature to frequency. The output of the device is a free-running, 50% duty-cycle square wave with a frequency that is proportional to the absolute temperature (°K) of the device (Figure 2). The MAX6577 has a push/pull CMOS output with sharp edges. The speed of the output square wave can be selected by hard-wiring TS1 and TS0 as shown in Table 2. One of four scaled output frequencies can be selected using TS1 and TS0.

SOT Temperature Sensors with Period/Frequency Output

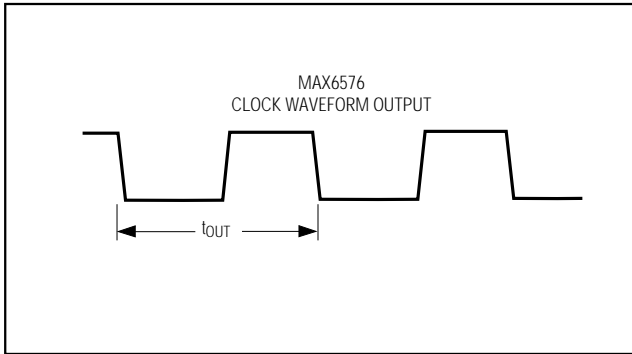

Figure 1. MAX6576 Timing Diagram

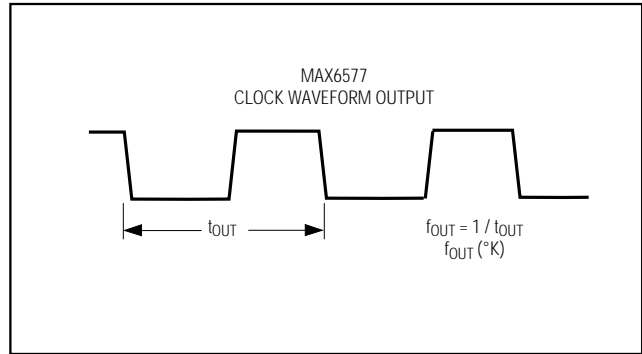

Figure 2. MAX6577 Timing Diagram

Applications Information

Quick-Look Circuits

Figure 3 shows a quick-look application circuit for the MAX6576 using a universal counter measuring period. TS1 and TS0 are both tied to ground to select a scalar multiplier of $10\mu s/^{\circ}K$. The MAX6576 converts the ambient temperature into a square wave with a period that is 10 times the absolute temperature of the device in μs . At room temperature, the universal counter will display approximately $2980\mu s$.

Figure 4 shows a quick-look application circuit for the MAX6577 using a universal counter measuring frequency. TS1 is tied to ground and TS0 is tied to V_{DD} to select a scalar multiplier of $1Hz/^{\circ}K$. The MAX6577 converts the ambient temperature into a square wave with a frequency that is equal to the absolute temperature of the device in Hertz. At room temperature, the universal counter will display approximately 298Hz.

Interfacing with a Microcontroller

Figure 5 shows the MAX6577 interfaced with an 8051 μC . In this example, TS1 is tied to ground and TS0 is

tied to V_{DD} to select a scalar multiplier of $1Hz/^{\circ}K$. The MAX6577 converts the ambient temperature into a square wave with a frequency that is equal to the absolute temperature of the device in Hertz. The 8051 μC reads the frequency of the square-wave output of the MAX6577 into Timer 0 and displays the temperature as degrees Celsius in binary on Port 1. Listing 1 provides the code for this application. The interface is similar for the MAX6576, except the μC will perform a period measurement.

Noise Considerations

The accuracy of the MAX6576/MAX6577 is susceptible to noise generated both internally and externally. The effects of external noise can be minimized by placing a $0.1\mu F$ ceramic bypass capacitor close to the supply pin of the devices. Internal noise is inherent in the operation of the devices and is detailed in Table 3. Internal averaging minimizes the effect of this noise when using longer scalar timeout multipliers. The effects of this noise are included in the overall accuracy of the devices as specified in the *Electrical Characteristics*.

SOT Temperature Sensors with Period/Frequency Output

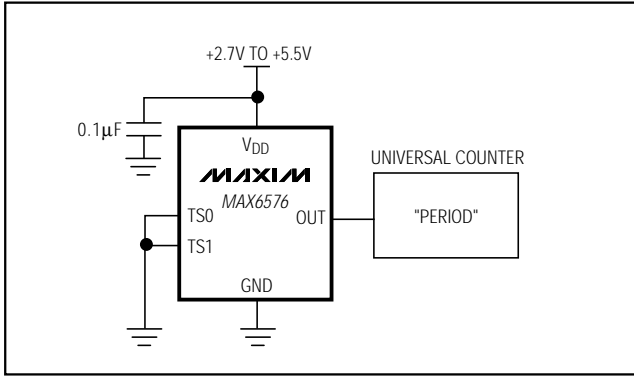

Figure 3. MAX6576 Quick-Look Circuit

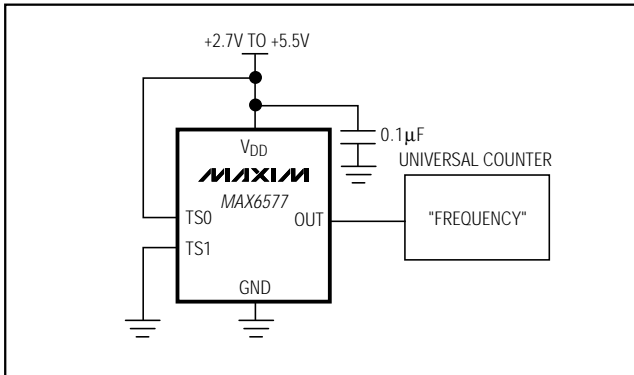

Figure 4. MAX6577 Quick-Look Circuit

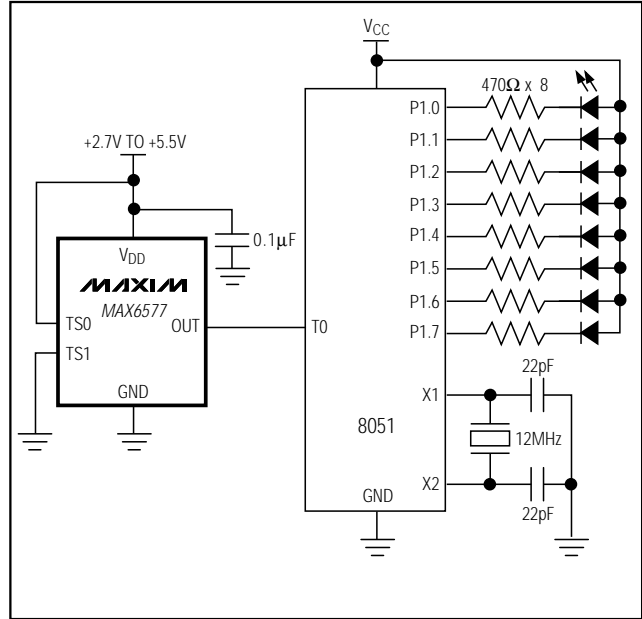

Figure 5. Interfacing with a μ C

Chip Information
TRANSISTOR COUNT: 302

Table 3. Typical Peak Noise Amplitude

PARAMETER	MAX6576				MAX6577			
	10	40	160	640	4	1	1/4	1/16
Scalar Multiplier	10	40	160	640	4	1	1/4	1/16
Noise Amplitude ($^{\circ}$ C)	± 0.38	± 0.17	± 0.11	± 0.094	± 0.13	± 0.066	± 0.040	± 0.028

SOT Temperature Sensors with Period/Frequency Output

Listing 1. 8051 Code Example

```

;*****
; Demonstration and test code for MAX6577 Temp to Frequency
; Takes in temperature values from a sensor into timer 0
; and displays temp as degrees C in binary on port 1.
; example: room temp= 21 C, display 21 or 00010101 on P1
;*****
;EQUATES
TEMPH      EQU    10H                ;TEMPERATURE
TEMPL      EQU    11H
TICKS      EQU    12H                ;number of 50 ms- counts to 1 second

NEWT       BIT    00h                ;new temp flag- bit address in 20h
;MAIN
          ORG    0                    ;note one isr's used- timer overflow
          AJMP  BEGIN                 ;jump over isr's
          ORG    1BH                  ;TF1 ISR
TICK:     PUSH  ACC                   ;stash acc
          PUSH  PSW                   ;stash psw
; reload timer- 50 ms
          CLR   C                     ;clear for subb
          MOV   A,#0B0H               ;latency fix
          SUBB  A,TL1                 ;subtract timer low latency < 20
          MOV   TL1,A                 ;50 ms reload value- low
          MOV   TH1,#03CH             ;50 ms reload value- high
          DJNZ  TICKS,NORL            ;jump over counter code
          MOV   TICKS,#20             ;reload ticks
;read counter to temp1 and temp high if 1 second
GTAG:     MOV   A,TH0                 ;get timer high
          MOV   B,TL0                 ;grab timer low
          CJNE  A,TH0,GTAG            ;get again if rollover
          MOV   TEMPH,A               ;stash high
          MOV   TEMPL,B               ;stash low
          MOV   TH0,#0                ;zero counter
          MOV   TL0,#0                ;zero counter
          SETB  NEWT                  ;set data ready flag
NORL:     POP   PSW
          POP   ACC
          RETI                         ;done

BEGIN:     MOV   SP,#70h              ;set sp at 70H
;setup timers to do timing- t0 input, t1 timer 50 ms
          MOV   TMOD,#15H             ;t1 timer- t0 counter
          MOV   TH1,#03CH             ;50 ms reload value- high
          MOV   TL1,#0B0H            ;50 ms reload value- low
          MOV   TL0,#0                ;reset counter low
          MOV   TH0,#0                ;reset counter high
          MOV   TCON,#50H             ;start both timers
          MOV   TICKS,#20             ;20 x 50 ms = 1 sec
          MOV   IE,#88H               ;enable t1 ints and global
;
;inits done- measure
DOTMP:     CLR   NEWT                 ;clear data flag
WAITT:     JNB  NEWT,WAITT            ;wait for data

; temp is stored- display bin value of selected on P1

```

SOT Temperature Sensors with Period/Frequency Output

Listing 1. 8051 Code Example (continued)

```

; temp is in kelvin- subtract 273
MOV  A,TEMPL      ;get temp (K)
CLR  C            ;ready for subb
SUBB A,#011H     ;sub low byte of 273
MOV  TEMPL,A     ;stash back
MOV  A,TEMPH     ;get high byte for completeness
SUBB A,#01H      ;sub high byte and prop carry
MOV  TEMPH,A     ;stash

;display it
MOV  A,TEMPL     ;get temp (C)
CPL  A           ;compliment for led's- active low
MOV  P1,A        ;output it
JMP  DOTMP

END
    
```

Package Information

SYMBOL	MIN	MAX
A	0.90	1.45
A1	0.00	0.15
A2	0.90	1.30
b	0.35	0.50
C	0.08	0.20
D	2.80	3.00
E	2.60	3.00
E1	1.50	1.75
L	0.35	0.55
e	0.95 REF	
a	0°	10°

NOTE:

- ALL DIMENSIONS ARE IN MILLIMETERS.
- FOOT LENGTH MEASURED AT INTERCEPT POINT BETWEEN DATUM A & LEAD SURFACE.
- PACKAGE OUTLINE EXCLUSIVE OF MOLD FLASH & METAL BURR.
- PACKAGE OUTLINE INCLUSIVE OF SOLDER PLATING.
- PIN 1 IS LOWER LEFT PIN WHEN READING TOP MARK FROM LEFT TO RIGHT. (SEE EXAMPLE TOP MARK)
- PIN 1 I.D. DOT IS 0.3 MM Ø MIN. LOCATED ABOVE PIN 1.

MAXIM		
<small>PROPRIETARY INFORMATION</small>		
<small>TITLE:</small>		
PACKAGE OUTLINE, SOT23, 6L		
<small>APPROVAL</small>	<small>DOCUMENT CONTROL NO.</small>	<small>REV</small>
	21-0058	D 1/1

6LSOT.EPS

Maxim cannot assume responsibility for use of any circuitry other than circuitry entirely embodied in a Maxim product. No circuit patent licenses are implied. Maxim reserves the right to change the circuitry and specifications without notice at any time.

8 Maxim Integrated Products, 120 San Gabriel Drive, Sunnyvale, CA 94086 408-737-7600