

## DM5401/DM7401 Quad 2-Input NAND Gates with Open-Collector Outputs

### General Description

This device contains four independent gates each of which performs the logic NAND function. The open-collector outputs require external pull-up resistors for proper logical operation.

### Pull-Up Resistor Equations

$$R_{MAX} = \frac{V_{CC} (Min) - V_{OH}}{N_1 (I_{OH}) + N_2 (I_{IH})}$$

$$R_{MIN} = \frac{V_{CC} (Max) - V_{OL}}{I_{OL} - N_3 (I_{IL})}$$

Where:  $N_1 (I_{OH})$  = total maximum output high current for all outputs tied to pull-up resistor

$N_2 (I_{IH})$  = total maximum input high current for all inputs tied to pull-up resistor

$N_3 (I_{IL})$  = total maximum input low current for all inputs tied to pull-up resistor

### Connection Diagram

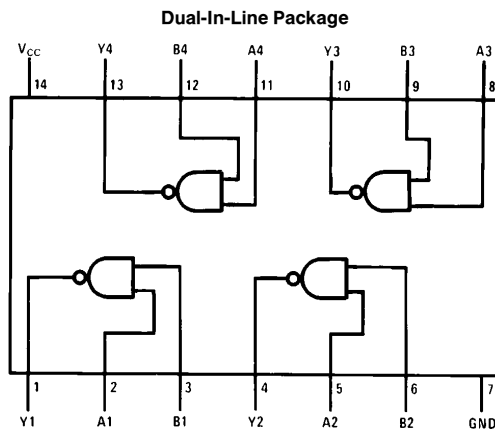

TL/F/6614-1

Order Number DM5401J, DM5401W or DM7401N  
See NS Package Number J14A, N14A or W14B

### Function Table

$$Y = \overline{AB}$$

| Inputs |   | Output |
|--------|---|--------|
| A      | B | Y      |
| L      | L | H      |
| L      | H | H      |
| H      | L | H      |
| H      | H | L      |

H = High Logic Level

L = Low Logic Level

## Absolute Maximum Ratings (Note)

If Military/Aerospace specified devices are required, please contact the National Semiconductor Sales Office/Distributors for availability and specifications.

|                                      |                 |
|--------------------------------------|-----------------|
| Supply Voltage                       | 7V              |
| Input Voltage                        | 5.5V            |
| Output Voltage                       | 7V              |
| Operating Free Air Temperature Range |                 |
| DM54                                 | −55°C to +125°C |
| DM74                                 | 0°C to +70°C    |
| Storage Temperature Range            | −65°C to +150°C |

Note: The "Absolute Maximum Ratings" are those values beyond which the safety of the device cannot be guaranteed. The device should not be operated at these limits. The parametric values defined in the "Electrical Characteristics" table are not guaranteed at the absolute maximum ratings. The "Recommended Operating Conditions" table will define the conditions for actual device operation.

## Recommended Operating Conditions

| Symbol          | Parameter                      | DM5401 |     |     | DM7401 |     |      | Units |
|-----------------|--------------------------------|--------|-----|-----|--------|-----|------|-------|
|                 |                                | Min    | Nom | Max | Min    | Nom | Max  |       |
| V <sub>CC</sub> | Supply Voltage                 | 4.5    | 5   | 5.5 | 4.75   | 5   | 5.25 | V     |
| V <sub>IH</sub> | High Level Input Voltage       | 2      |     |     | 2      |     |      | V     |
| V <sub>IL</sub> | Low Level Input Voltage        |        |     | 0.8 |        |     | 0.8  | V     |
| V <sub>OH</sub> | High Level Output Voltage      |        |     | 5.5 |        |     | 5.5  | V     |
| I <sub>OL</sub> | Low Level Output Current       |        |     | 16  |        |     | 16   | mA    |
| T <sub>A</sub>  | Free Air Operating Temperature | −55    |     | 125 | 0      |     | 70   | °C    |

## Electrical Characteristics over recommended operating free air temperature range (unless otherwise noted)

| Symbol           | Parameter                         | Conditions  | Min | Typ (Note 1) | Max  | Units |
|------------------|-----------------------------------|---|-----|--------------|------|-------|
| V <sub>I</sub>   | Input Clamp Voltage               | V <sub>CC</sub> = Min, I <sub>I</sub> = −12 mA                        |     |              | −1.5 | V     |
| I <sub>CEX</sub> | High Level Output Current         | V <sub>CC</sub> = Min, V <sub>O</sub> = 5.5V<br>V <sub>IL</sub> = Max |     |              | 250  | μA    |
| V <sub>OL</sub>  | Low Level Output Voltage          | V <sub>CC</sub> = Min, I <sub>OL</sub> = Max<br>V <sub>IH</sub> = Min |     | 0.2          | 0.4  | V     |
| I <sub>I</sub>   | Input Current @ Max Input Voltage | V <sub>CC</sub> = Max, V <sub>I</sub> = 5.5V                          |     |              | 1    | mA    |
| I <sub>IH</sub>  | High Level Input Current          | V <sub>CC</sub> = Max, V <sub>I</sub> = 2.4V                          |     |              | 40   | μA    |
| I <sub>IL</sub>  | Low Level Input Current           | V <sub>CC</sub> = Max, V <sub>I</sub> = 0.4V                          |     |              | −1.6 | mA    |
| I <sub>CC</sub>  | Supply Current with Outputs High  | V <sub>CC</sub> = Max   |     | 4            | 8    | mA    |
| I <sub>CC</sub>  | Supply Current with Outputs Low   | V <sub>CC</sub> = Max   |     | 12           | 22   | mA    |

## Switching Characteristics at V<sub>CC</sub> = 5V and T<sub>A</sub> = 25°C (See Section 1 for Test Waveforms and Output Load)

| Symbol           | Parameter                                       | Conditions   | Min | Max | Units |
|------------------|---|--|-----|-----|-------|
| t <sub>PLH</sub> | Propagation Delay Time Low to High Level Output | C <sub>L</sub> = 15 pF<br>R <sub>L</sub> = 4 kΩ (t <sub>PLH</sub> )<br>R <sub>L</sub> = 400Ω (t <sub>PHL</sub> ) |     | 45  | ns    |
| t <sub>PHL</sub> | Propagation Delay Time High to Low Level Output |  |     | 15  | ns    |

Note 1: All typicals are at V<sub>CC</sub> = 5V, T<sub>A</sub> = 25°C.

**Physical Dimensions** inches (millimeters)

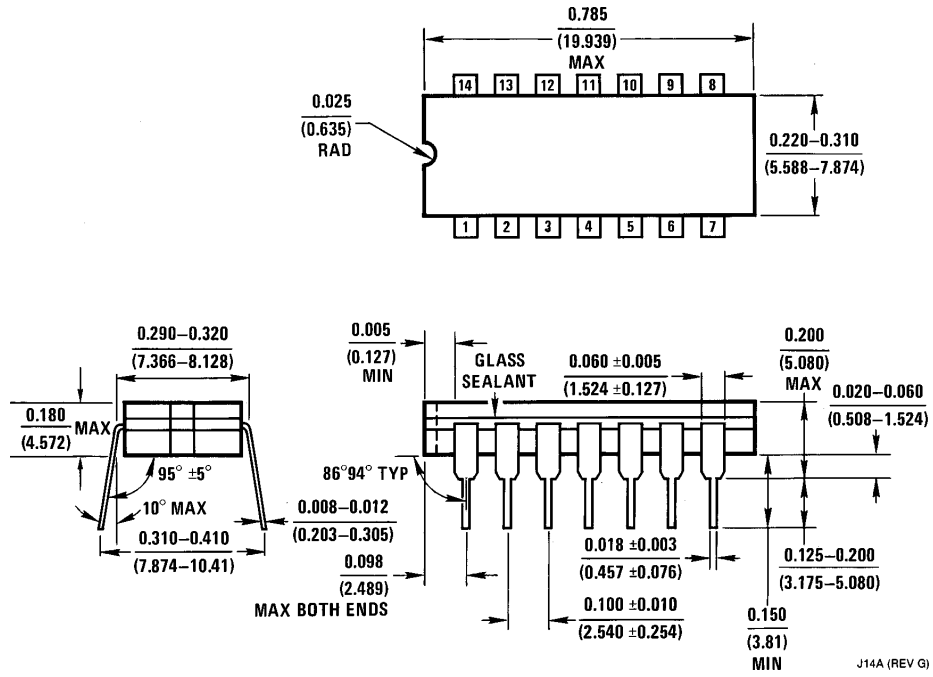

**14-Lead Ceramic Dual-In-Line Package (J)**  
Order Number DM5401J  
NS Package Number J14A

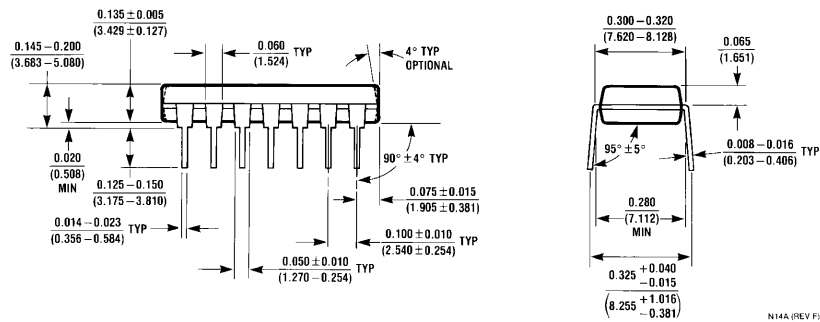
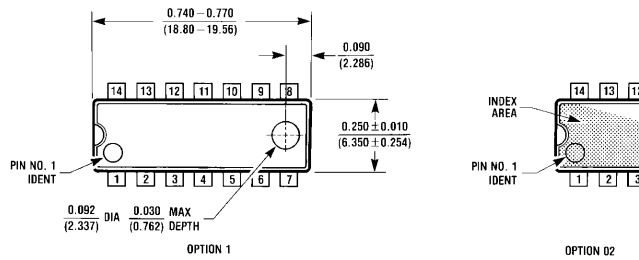

**14-Lead Molded Dual-In-Line Package (N)**  
Order Number DM7401N  
NS Package Number N14A

**Physical Dimensions** inches (millimeters) (Continued)



**14-Lead Ceramic Flat Package (W)  
Order Number DM5401W  
NS Package Number W14B**

**LIFE SUPPORT POLICY**

NATIONAL'S PRODUCTS ARE NOT AUTHORIZED FOR USE AS CRITICAL COMPONENTS IN LIFE SUPPORT DEVICES OR SYSTEMS WITHOUT THE EXPRESS WRITTEN APPROVAL OF THE PRESIDENT OF NATIONAL SEMICONDUCTOR CORPORATION. As used herein:

1. Life support devices or systems are devices or systems which, (a) are intended for surgical implant into the body, or (b) support or sustain life, and whose failure to perform, when properly used in accordance with instructions for use provided in the labeling, can be reasonably expected to result in a significant injury to the user.
2. A critical component is any component of a life support device or system whose failure to perform can be reasonably expected to cause the failure of the life support device or system, or to affect its safety or effectiveness.



**National Semiconductor Corporation**  
1111 West Bardin Road  
Arlington, TX 76017  
Tel: 1(800) 272-9959  
Fax: 1(800) 737-7018

**National Semiconductor Europe**  
Fax: (+49) 0-180-530 85 86  
Email: cnjwge@tevm2.nsc.com  
Deutsch Tel: (+49) 0-180-530 85 85  
English Tel: (+49) 0-180-532 78 32  
Français Tel: (+49) 0-180-532 93 58  
Italiano Tel: (+49) 0-180-534 16 80

**National Semiconductor Hong Kong Ltd.**  
19th Floor, Straight Block,  
Ocean Centre, 5 Canton Rd.  
Tsimshatsui, Kowloon  
Hong Kong  
Tel: (852) 2737-1600  
Fax: (852) 2736-9960

**National Semiconductor Japan Ltd.**  
Tel: 81-043-299-2309  
Fax: 81-043-299-2408

National does not assume any responsibility for use of any circuitry described, no circuit patent licenses are implied and National reserves the right at any time without notice to change said circuitry and specifications.