

54LS253/DM54LS253/DM74LS253 TRI-STATE® Data Selectors/Multiplexers

General Description

Each of these Schottky-clamped data selectors/multiplexers contains inverters and drivers to supply fully complementary, on-chip, binary decoding data selection to the AND-OR gates. Separate output control inputs are provided for each of the two four-line sections.

The TRI-STATE outputs can interface directly with data lines of bus-organized systems. With all but one of the common outputs disabled (at a high impedance state), the low impedance of the single enabled output will drive the bus line to a high or low logic level.

Features

- TRI-STATE version of LS153 with same pinout
- Schottky-diode-clamped transistors
- Permit multiplexing from N-lines to one line
- Performs parallel-to-serial conversion
- Strobe/output control
- High fanout totem-pole outputs
- Typical propagation delay
 - Data to output 12 ns
 - Select to output 21 ns
- Typical power dissipation 35 mW
- Alternate Military/Aerospace device (54LS253) is available. Contact a National Semiconductor Sales Office/Distributor for specifications.

Connection Diagram

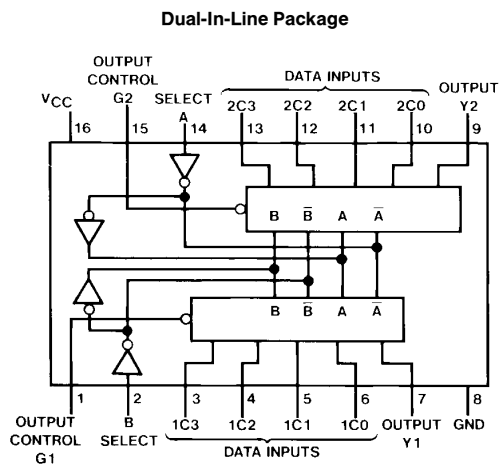

**Order Number 54LS253DMQB, 54LS253FMQB,
54LS253LMQB, DM54LS253J, DM54LS253W,
DM74LS253M or DM74LS253N
See NS Package Number E20A, J16A,
M16A, N16E or W16A**

Function Table

Select Inputs		Data Inputs				Output Control	Output
B	A	C0	C1	C2	C3	G	Y
X	X	X	X	X	X	H	Z
L	L	L	X	X	X	L	L
L	L	H	X	X	X	L	H
L	H	X	L	X	X	L	L
L	H	X	H	X	X	L	H
H	L	X	X	L	X	L	L
H	L	X	X	H	X	L	H
H	H	X	X	X	L	L	L
H	H	X	X	X	H	L	H

Address Inputs A and B are common to both sections.
H = High Level, L = Low Level, X = Don't Care, Z = High Impedance (off).

Absolute Maximum Ratings (Note)

If Military/Aerospace specified devices are required, please contact the National Semiconductor Sales Office/Distributors for availability and specifications.

Supply Voltage	7V
Input Voltage	7V
Operating Free Air Temperature Range	
DM54LS and 54LS	–55°C to +125°C
DM74LS	0°C to +70°C
Storage Temperature Range	–65°C to +150°C

Note: The “Absolute Maximum Ratings” are those values beyond which the safety of the device cannot be guaranteed. The device should not be operated at these limits. The parametric values defined in the “Electrical Characteristics” table are not guaranteed at the absolute maximum ratings. The “Recommended Operating Conditions” table will define the conditions for actual device operation.

Recommended Operating Conditions

Symbol	Parameter	DM54LS253			DM74LS253			Units
		Min	Nom	Max	Min	Nom	Max	
V _{CC}	Supply Voltage	4.5	5	5.5	4.75	5	5.25	V
V _{IH}	High Level Input Voltage	2			2			V
V _{IL}	Low Level Input Voltage			0.7			0.8	V
I _{OH}	High Level Output Current			–1			–2.6	mA
I _{OL}	Low Level Output Current			12			24	mA
T _A	Free Air Operating Temperature	–55		125	0		70	°C

Electrical Characteristics over recommended operating free air temperature range (unless otherwise noted)

Symbol	Parameter	Conditions	Min	Typ (Note 1)	Max	Units
V _I	Input Clamp Voltage	V _{CC} = Min, I _I = –18 mA			–1.5	V
V _{OH}	High Level Output Voltage	V _{CC} = Min, I _{OH} = Max V _{IL} = Max, V _{IH} = Min	DM54	2.4	3.4	V
			DM74	2.4	3.1	
V _{OL}	Low Level Output Voltage	V _{CC} = Min, I _{OL} = Max V _{IL} = Max, V _{IH} = Min	DM54		0.4	V
			DM74		0.5	
		I _{OL} = 12 mA, V _{CC} = Min	DM74		0.4	
I _I	Input Current @ Max Input Voltage	V _{CC} = Max, V _I = 7V			0.1	mA
I _{IH}	High Level Input Current	V _{CC} = Max, V _I = 2.7V			20	μA
I _{IL}	Low Level Input Current	V _{CC} = Max, V _I = 0.4V			–0.4	mA
I _{OZH}	Off-State Output Current with High Level Output Voltage Applied	V _{CC} = Max, V _O = 2.7V V _{IH} = Min, V _{IL} = Max			20	μA
I _{OZL}	Off-State Output Current with Low Level Output Voltage Applied	V _{CC} = Max, V _O = 0.4 V _{IH} = Min, V _{IL} = Max			–20	μA
I _{OS}	Short Circuit Output Current	V _{CC} = Max (Note 2)	DM54	–20	–100	mA
			DM74	–20	–100	
I _{CC1}	Supply Current	V _{CC} = Max (Note 3)		7	12	mA
I _{CC2}	Supply Current	V _{CC} = Max (Note 4)		8.5	14	mA

Note 1: All typicals are at V_{CC} = 5V, T_A = 25°C.

Note 2: Not more than one output should be shorted at a time, and the duration should not exceed one second.

Note 3: I_{CC1} is measured with all outputs open, and all the inputs grounded.

Note 4: I_{CC2} is measured with the outputs open, OUTPUT CONTROL at 4.5V and all other inputs grounded.

Switching Characteristics at $V_{CC} = 5V$ and $T_A = 25^\circ C$ (See Section 1 for Test Waveforms and Output Load)

Symbol	Parameter	From (Input) To (Output)	$R_L = 667\Omega$				Units
			$C_L = 45\text{ pF}$		$C_L = 150\text{ pF}$		
			Min	Max	Min	Max	
t_{PLH}	Propagation Delay Time Low to High Level Output	Data to Y		25		35	ns
t_{PHL}	Propagation Delay Time High to Low Level Output	Data to Y		20		30	ns
t_{PLH}	Propagation Delay Time Low to High Level Output	Select to Y		45		54	ns
t_{PHL}	Propagation Delay Time High to Low Level Output	Select to Y		32		44	ns
t_{PZH}	Output Enable Time to High Level Output	Output Control to Y		18		32	ns
t_{PZL}	Output Enable Time to Low Level Output	Output Control to Y		23		35	ns
t_{PHZ}	Output Disable Time from High Level Output (Note 1)	Output Control to Y		41			ns
t_{PLZ}	Output Disable Time from Low Level Output (Note 1)	Output Control to Y		27			ns

Note 1: $C_L = 5\text{ pF}$.

Logic Diagram

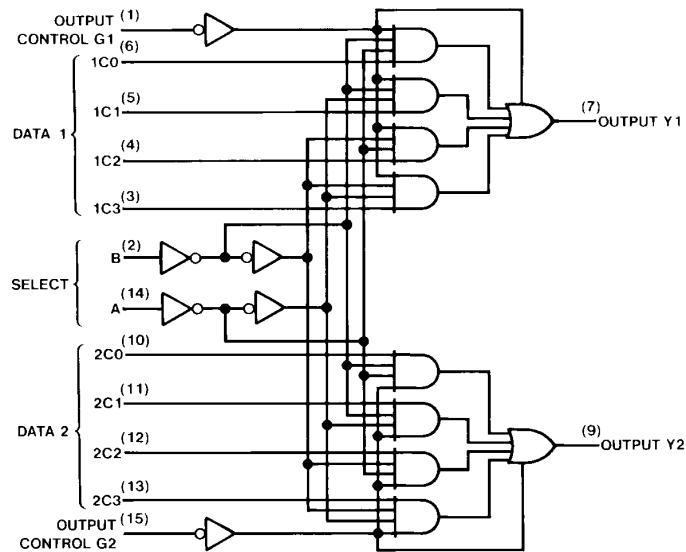

TL/F/6416-2

Physical Dimensions inches (millimeters)

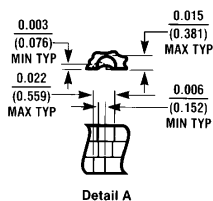
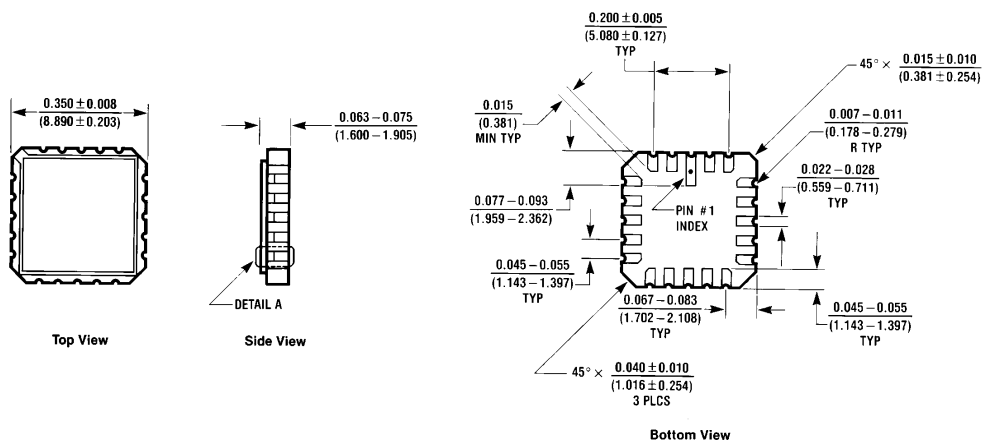

Ceramic Leadless Chip Carrier Package (E)
Order Number 54LS253LMQB
NS Package Number E20A

E20A (REV D)

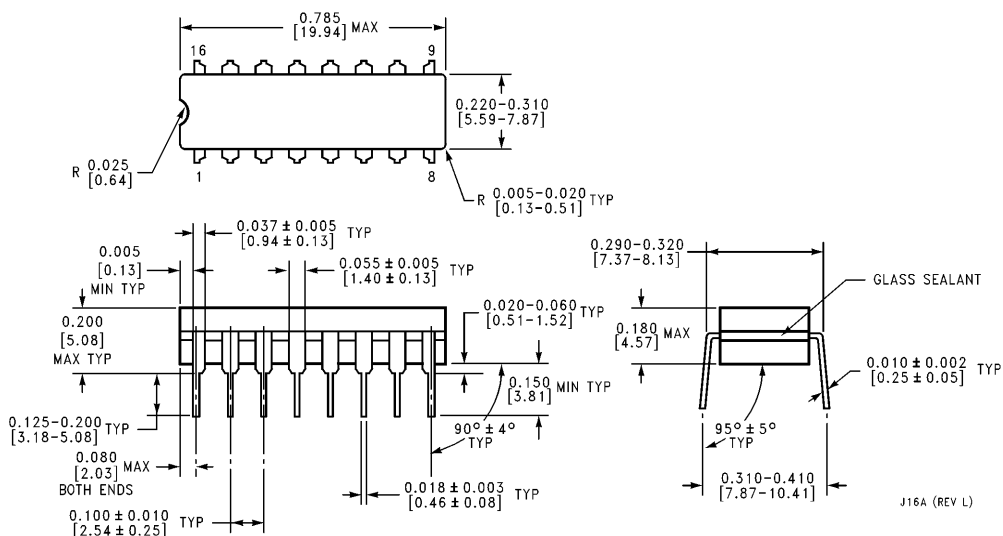

16-Lead Ceramic Dual-In-Line Package (J)
Order Number 54LS253DMQB or DM54LS253J
NS Package Number J16A

J16A (REV L)

Physical Dimensions inches (millimeters) (Continued)

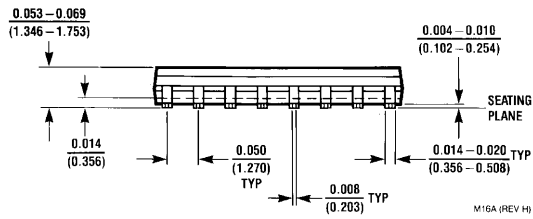
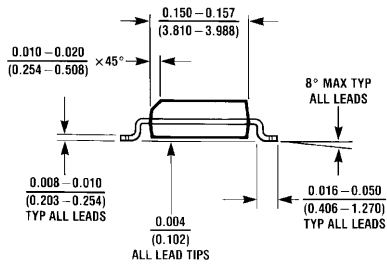
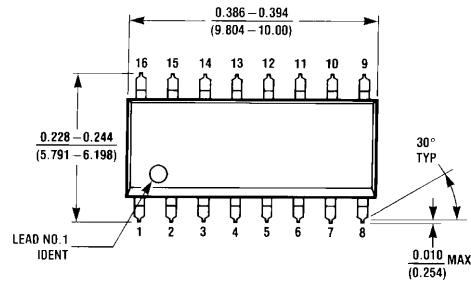

16-Lead Small Outline Molded Package (M)
Order Number DM74LS253M
NS Package Number M16A

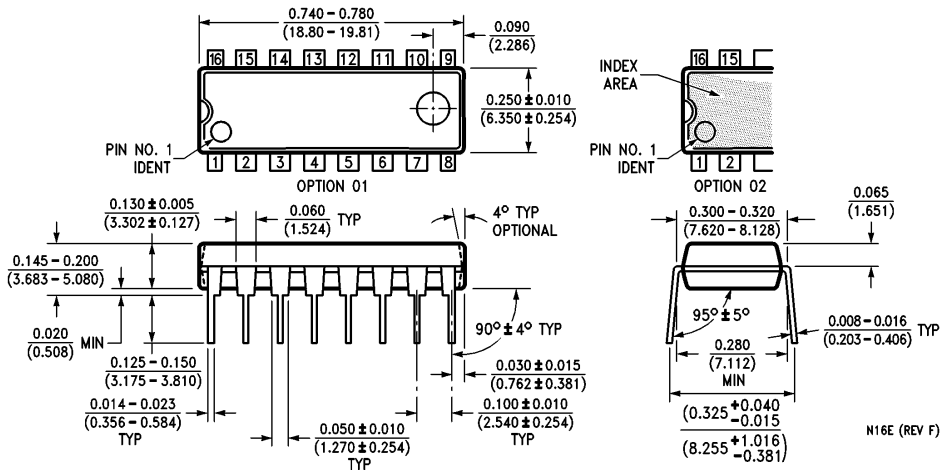

16-Lead Molded Dual-In-Line Package (N)
Order Number DM74LS253N
NS Package Number N16E

Physical Dimensions inches (millimeters) (Continued)

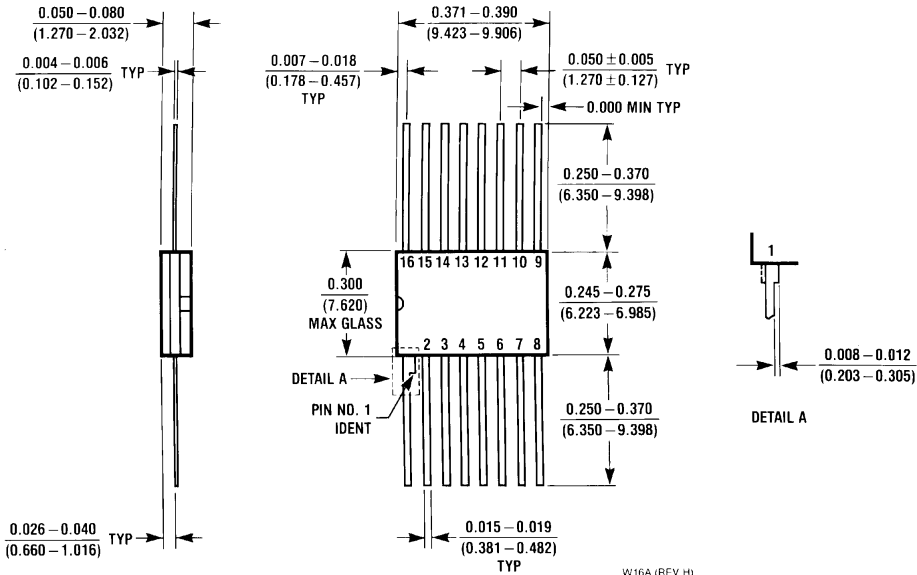

16-Lead Ceramic Flat Package (W)
Order Number 54LS253FMQB or DM54LS253W
NS Package Number W16A

LIFE SUPPORT POLICY

NATIONAL'S PRODUCTS ARE NOT AUTHORIZED FOR USE AS CRITICAL COMPONENTS IN LIFE SUPPORT DEVICES OR SYSTEMS WITHOUT THE EXPRESS WRITTEN APPROVAL OF THE PRESIDENT OF NATIONAL SEMICONDUCTOR CORPORATION. As used herein:

1. Life support devices or systems are devices or systems which, (a) are intended for surgical implant into the body, or (b) support or sustain life, and whose failure to perform, when properly used in accordance with instructions for use provided in the labeling, can be reasonably expected to result in a significant injury to the user.
2. A critical component is any component of a life support device or system whose failure to perform can be reasonably expected to cause the failure of the life support device or system, or to affect its safety or effectiveness.



National Semiconductor Corporation
 1111 West Bardin Road
 Arlington, TX 76017
 Tel: 1(800) 272-9959
 Fax: 1(800) 737-7018

National Semiconductor Europe
 Fax: (+49) 0-180-530 85 86
 Email: cnjwge@tevm2.nsc.com
 Deutsch Tel: (+49) 0-180-530 85 85
 English Tel: (+49) 0-180-532 78 32
 Français Tel: (+49) 0-180-532 93 58
 Italiano Tel: (+49) 0-180-534 16 80

National Semiconductor Hong Kong Ltd.
 19th Floor, Straight Block,
 Ocean Centre, 5 Canton Rd.
 Tsimshatsui, Kowloon
 Hong Kong
 Tel: (852) 2737-1600
 Fax: (852) 2736-9960

National Semiconductor Japan Ltd.
 Tel: 81-043-299-2309
 Fax: 81-043-299-2408

National does not assume any responsibility for use of any circuitry described, no circuit patent licenses are implied and National reserves the right at any time without notice to change said circuitry and specifications.