

## 54LS256/DM74LS256 Dual 4-Bit Addressable Latch

### General Description

The  $\overline{\text{LS256}}$  is a dual 4-bit addressable latch with common control inputs; these include two Address inputs (A0, A1), an active LOW enable input ( $\overline{\text{E}}$ ) and an active LOW Clear input (CL). Each latch has a Data input (D) and four outputs (Q0–Q3).

When the Enable ( $\overline{\text{E}}$ ) is HIGH and the Clear input ( $\overline{\text{CL}}$ ) is LOW, all outputs (Q0–Q3) are LOW. Dual 4-channel demultiplexing occurs when the  $\overline{\text{CL}}$  and  $\overline{\text{E}}$  are both LOW. When  $\overline{\text{CL}}$  is HIGH and  $\overline{\text{E}}$  is LOW, the selected output (Q0–Q3), determined by the Address inputs, follows D. When the  $\overline{\text{E}}$  goes HIGH, the contents of the latch are stored. When operating in the addressable latch mode ( $\overline{\text{E}}$  = LOW,  $\overline{\text{CL}}$  = HIGH), changing more than one bit of the Address (A0, A1)

could impose a transient wrong address. Therefore, this should be done only while in the memory mode ( $\overline{\text{E}}$  =  $\overline{\text{CL}}$  = HIGH).

### Features

- Serial-to-parallel capability
- Output from each storage bit available
- Random (addressable) data entry
- Easily expandable
- Active low common clear

### Connection Diagram

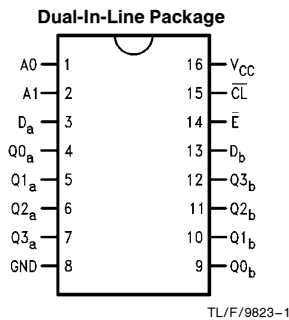

Order Number 54LS256DMQB,  
54LS256FMQB or DM74LS256N  
See NS Package Number J16A,  
N16E or W16A

### Logic Symbol

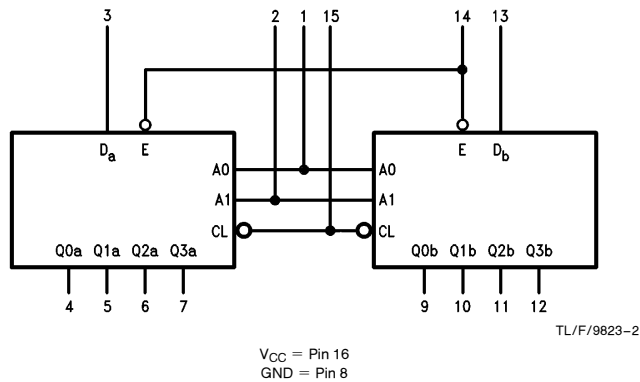

Pin Names	Description
A0, A1	Common Address Inputs
D <sub>a</sub> , D <sub>b</sub>	Data Inputs
$\overline{\text{E}}$	Common Enable Input (Active LOW)
$\overline{\text{CL}}$	Conditional Clear Input (Active LOW)
Q0 <sub>a</sub> –Q3 <sub>a</sub>	Side A Latch Outputs
Q0 <sub>b</sub> –Q3 <sub>b</sub>	Side B Latch Outputs

## Truth Table

Inputs				Outputs				Mode
$\overline{CL}$	$\overline{E}$	A0	A1	Q0	Q1	Q2	Q3	
L	H	X	X	L	L	L	L	Clear
L	L	L	L	D	L	L	L	Demultiplex
L	L	H	L	L	D	L	L	
L	L	L	H	L	L	D	L	
L	L	H	H	L	L	L	D	
H	H	X	X	$Q_{t-1}$	$Q_{t-1}$	$Q_{t-1}$	$Q_{t-1}$	Memory
H	L	L	L	D	$Q_{t-1}$	$Q_{t-1}$	$Q_{t-1}$	Addressable Latch
H	L	H	L	$Q_{t-1}$	D	$Q_{t-1}$	$Q_{t-1}$	
H	L	L	H	$Q_{t-1}$	$Q_{t-1}$	D	$Q_{t-1}$	
H	L	H	H	$Q_{t-1}$	$Q_{t-1}$	$Q_{t-1}$	D	

$t-1$  = Bit time before address change or rising edge of E

H = HIGH Voltage Level

L = LOW Voltage Level

X = Immaterial

### Mode Selection

$\overline{E}$	$\overline{CL}$	Mode
L	H	Addressable Latch
H	H	Memory
L	L	Active HIGH 4-Channel Demultiplexers
H	L	Clear

## Logic Diagram

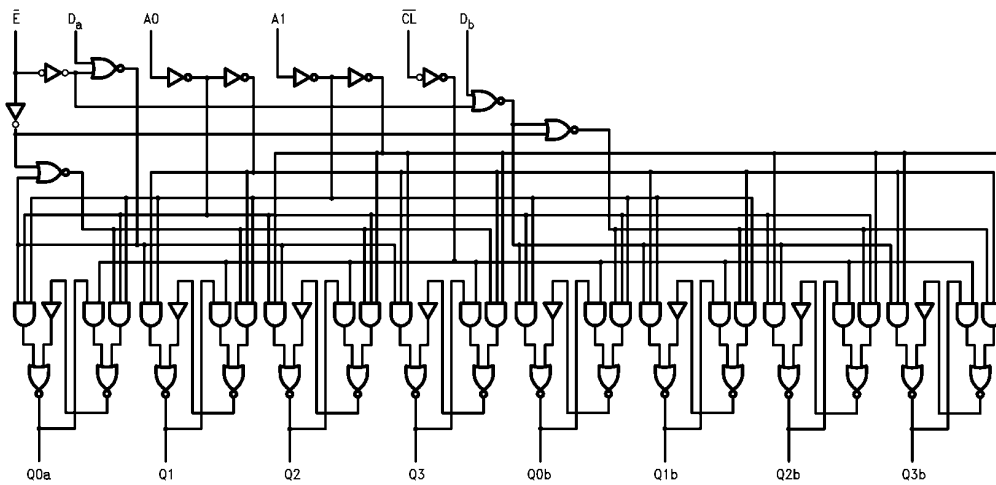

TL/F/9823-3

## Absolute Maximum Ratings (Note)

If Military/Aerospace specified devices are required, please contact the National Semiconductor Sales Office/Distributors for availability and specifications.

Supply Voltage	7V
Input Voltage	7V
Operating Free Air Temperature Range	
54LS	−55°C to +125°C
DM74LS	0°C to +70°C
Storage Temperature Range	−65°C to +150°C

Note: The "Absolute Maximum Ratings" are those values beyond which the safety of the device cannot be guaranteed. The device should not be operated at these limits. The parametric values defined in the "Electrical Characteristics" table are not guaranteed at the absolute maximum ratings. The "Recommended Operating Conditions" table will define the conditions for actual device operation.

## Recommended Operating Conditions

Symbol	Parameter	54LS256			DM74LS256			Units
		Min	Nom	Max	Min	Nom	Max	
V <sub>CC</sub>	Supply Voltage	4.5	5	5.5	4.75	5	5.25	V
V <sub>IH</sub>	High Level Input Voltage	2			2			V
V <sub>IL</sub>	Low Level Input Voltage			0.7			0.8	V
I <sub>OH</sub>	High Level Output Current			−0.4			−0.4	mA
I <sub>OL</sub>	Low Level Output Current			4			8	mA
T <sub>A</sub>	Free Air Operating Temperature	−55		125	0		70	°C
t <sub>s</sub> (H)	Setup Time HIGH, D <sub>n</sub> to $\bar{E}$	20			20			ns
t <sub>h</sub> (H)	Hold Time HIGH, D <sub>n</sub> to $\bar{E}$	0			0			ns
t <sub>s</sub> (L)	Setup Time LOW, D <sub>n</sub> to $\bar{E}$	15			15			ns
t <sub>h</sub> (L)	Hold Time LOW, D <sub>n</sub> to $\bar{E}$	0			0			ns
t <sub>s</sub> (H) t <sub>s</sub> (L)	Setup Time HIGH or LOW, A <sub>n</sub> to $\bar{E}$	0			0			ns
t <sub>w</sub> (L)	$\bar{E}$ Pulse Width LOW	17			17			ns

## Electrical Characteristics

Over recommended operating free air temperature range (unless otherwise noted)

Symbol	Parameter	Conditions	Min	Typ (Note 1)	Max	Units
V <sub>I</sub>	Input Clamp Voltage	V <sub>CC</sub> = Min, I <sub>I</sub> = −18 mA			−1.5	V
V <sub>OH</sub>	High Level Output Voltage	V <sub>CC</sub> = Min, I <sub>OH</sub> = Max V <sub>IL</sub> = Max	54LS 2.5 DM74 2.7	3.4		V
V <sub>OL</sub>	Low Level Output Voltage	V <sub>CC</sub> = Min, I <sub>OL</sub> = Max V <sub>IH</sub> = Min	54LS DM74	0.35	0.4 0.5	V
		I <sub>OL</sub> = 4 mA, V <sub>CC</sub> = Min	DM74	0.25	0.4	
I <sub>I</sub>	Input Current @ Max Input Voltage	V <sub>CC</sub> = Max, V <sub>I</sub> = 10V	Inputs $\bar{E}$		0.1 0.2	mA
I <sub>IH</sub>	High Level Input Current	V <sub>CC</sub> = Max, V <sub>I</sub> = 2.7V	Inputs $\bar{E}$		20 40	μA
I <sub>IL</sub>	Low Level Input Current	V <sub>CC</sub> = Max, V <sub>I</sub> = 0.4V	Inputs $\bar{E}$		−0.4 −0.8	mA
I <sub>OS</sub>	Short Circuit Output Current	V <sub>CC</sub> = Max (Note 2)	54LS DM74	−20 −20	−100 −100	mA
I <sub>CC</sub>	Supply Current	V <sub>CC</sub> = Max			25	mA

Note 1: All typicals are at V<sub>CC</sub> = 5V, T<sub>A</sub> = 25°C.

Note 2: Not more than one output should be shorted at a time, and the duration should not exceed one second.

## Switching Characteristics

$V_{CC} = +5.0V$ ,  $T_A = +25^\circ C$  (See Section 1 for waveforms and load configurations)

Symbol	Parameter	$R_L = 2\text{ k}\Omega$ $C_L = 15\text{ pF}$	Units
		Max	
$t_{PLH}$ $t_{PHL}$	Propagation Delay $\bar{E}$ to $Q_n$	27 24	ns
$t_{PLH}$ $t_{PHL}$	Propagation Delay $D_n$ to $Q_n$	30 20	ns
$t_{PLH}$ $t_{PHL}$	Propagation Delay $A_n$ to $Q_n$	30 29	ns
$t_{PLH}$	Propagation Delay $\overline{CL}$ to $Q_n$	18	ns

**Physical Dimensions** inches (millimeters)

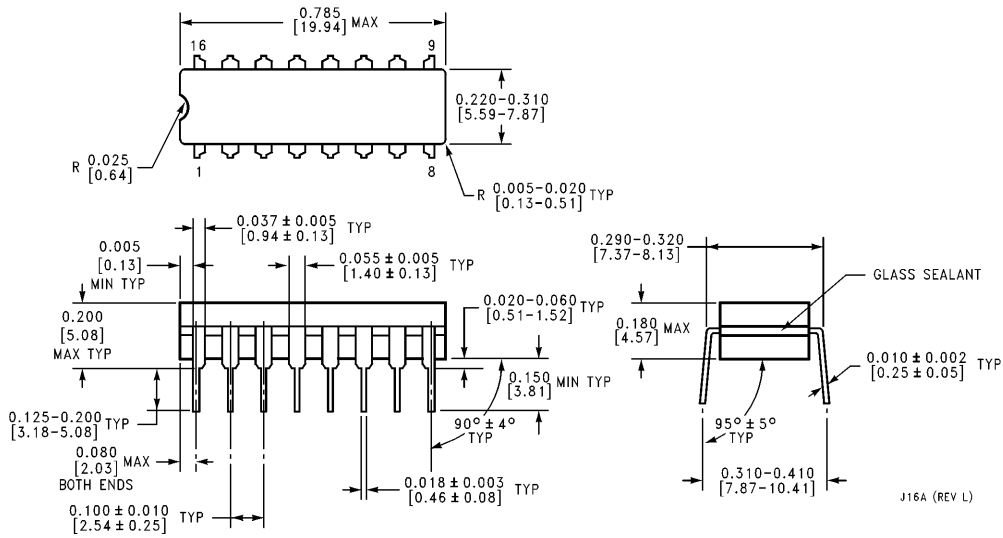

**16-Lead Ceramic Dual-In-Line Package (J)**  
**Order Number 54LS256DMQB**  
**NS Package Number J16A**

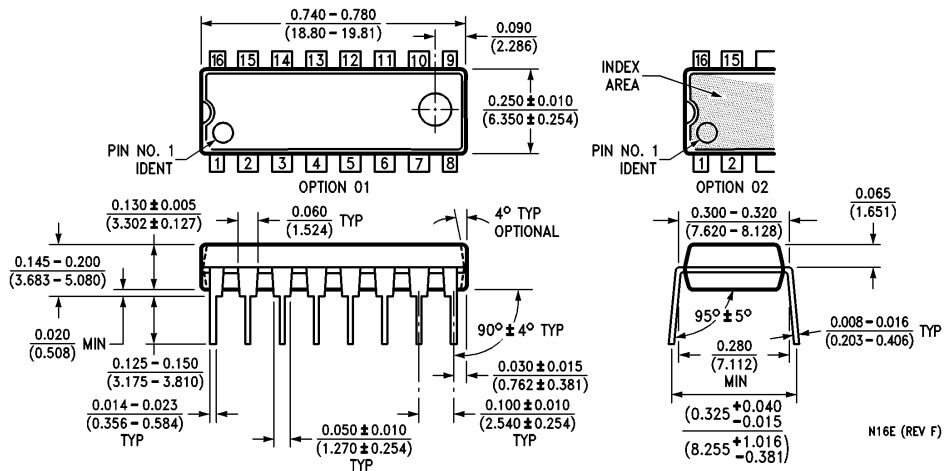

**16-Lead Molded Dual-In-Line Package (N)**  
**Order Number DM74LS256N**  
**NS Package Number N16E**

**Physical Dimensions** inches (millimeters) (Continued)

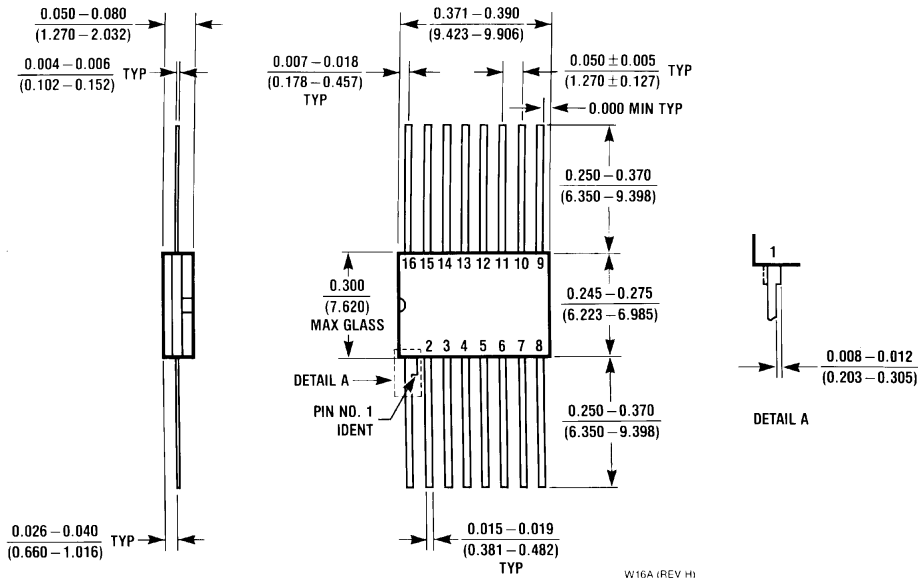

**16-Lead Ceramic Flat Package (W)**  
**Order Number 54LS256FMQB**  
**NS Package Number W16A**

**LIFE SUPPORT POLICY**

NATIONAL'S PRODUCTS ARE NOT AUTHORIZED FOR USE AS CRITICAL COMPONENTS IN LIFE SUPPORT DEVICES OR SYSTEMS WITHOUT THE EXPRESS WRITTEN APPROVAL OF THE PRESIDENT OF NATIONAL SEMICONDUCTOR CORPORATION. As used herein:

1. Life support devices or systems are devices or systems which, (a) are intended for surgical implant into the body, or (b) support or sustain life, and whose failure to perform, when properly used in accordance with instructions for use provided in the labeling, can be reasonably expected to result in a significant injury to the user.
2. A critical component is any component of a life support device or system whose failure to perform can be reasonably expected to cause the failure of the life support device or system, or to affect its safety or effectiveness.



**National Semiconductor Corporation**  
 1111 West Bardin Road  
 Arlington, TX 76017  
 Tel: 1(800) 272-9959  
 Fax: 1(800) 737-7018

**National Semiconductor Europe**  
 Fax: (+49) 0-180-530 85 86  
 Email: [cnjwge@tevm2.nsc.com](mailto:cnjwge@tevm2.nsc.com)  
 Deutsch Tel: (+49) 0-180-530 85 85  
 English Tel: (+49) 0-180-532 78 32  
 Français Tel: (+49) 0-180-532 93 58  
 Italiano Tel: (+49) 0-180-534 16 80

**National Semiconductor Hong Kong Ltd.**  
 19th Floor, Straight Block,  
 Ocean Centre, 5 Canton Rd.  
 Tsimshatsui, Kowloon  
 Hong Kong  
 Tel: (852) 2737-1600  
 Fax: (852) 2736-9960

**National Semiconductor Japan Ltd.**  
 Tel: 81-043-299-2309  
 Fax: 81-043-299-2408

National does not assume any responsibility for use of any circuitry described, no circuit patent licenses are implied and National reserves the right at any time without notice to change said circuitry and specifications.