

DM74LS48 BCD to 7-Segment Decoder

General Description

The 'LS48 translates four lines of BCD (8421) input data into the 7-segment numeral code and provides seven corresponding outputs having pull-up resistors, as opposed to totem pole pull-ups. These outputs can serve as logic signals, with a HIGH output corresponding to a lighted lamp segment, or can provide a 1.3 mA base current to npn lamp

driver transistors. Auxiliary inputs provide lamp test, blanking and cascadable zero-suppression functions.

The 'LS48 decodes the input data in the pattern indicated in the Truth Table and the segment identification illustration.

Connection Diagram

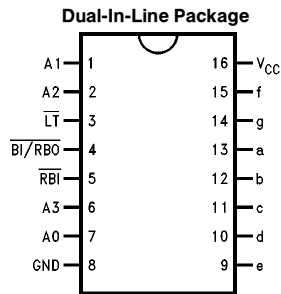

TL/F/10172-1

Order Number DM74LS48M or DM74LS48N
See NS Package Number M16A or N16E

Absolute Maximum Ratings (Note)

Supply Voltage	7V
Input Voltage	7V
Operating Free Air Temperature Range	0°C to +70°C
DM74LS	0°C to +70°C
Storage Temperature Range	-65°C to +150°C

Note: The "Absolute Maximum Ratings" are those values beyond which the safety of the device cannot be guaranteed. The device should not be operated at these limits. The parametric values defined in the "Electrical Characteristics" table are not guaranteed at the absolute maximum ratings. The "Recommended Operating Conditions" table will define the conditions for actual device operation.

Recommended Operating Conditions

Symbol	Parameter	DM74LS48			Units
		Min	Nom	Max	
V _{CC}	Supply Voltage	4.75	5	5.25	V
V _{IH}	High Level Input Voltage	2			V
V _{IL}	Low Level Input Voltage			0.8	V
I _{OH}	High Level Output Current			-50	μA
I _{OL}	Low Level Output Current			6.0	mA
T _A	Free Air Operating Temperature	0		70	°C

Electrical Characteristics over recommended operating free air temperature range (unless otherwise noted)

Symbol	Parameter	Conditions	Min	Typ (Note 1)	Max	Units
V _I	Input Clamp Voltage	V _{CC} = Min, I _I = -18 mA			-1.5	V
V _{OH}	High Level Output Voltage	V _{CC} Min, I _{OH} = Max, V _{IL} = Max	2.4			V
I _{OFF}	Output High Current Segment Outputs	V _{CC} = Min, V _O = 0.85V	-1.3			mA
V _{OL}	Low Level Output Voltage	V _{CC} = Min, I _{OL} = Max, V _{IH} = Min			0.5	V
		I _{OL} = 2.0 mA, V _{CC} = Min			0.4	
I _I	Input Current @ Max Input Voltage	V _{CC} = Max, V _I = 7V			0.1	mA
I _{IH}	High Level Input Current	V _{CC} = Max, V _I = 2.7V			20	μA
I _{IL}	Low Level Input Current	V _{CC} = Max, V _I = 0.4V			-0.4	mA
I _{OS}	Short Circuit Output Current	V _{CC} = Max, V _O = 0V at BI/RB \bar{O} (Note 2)	-0.3		-2	mA
I _{CCH}	Supply Current	V _{CC} = Max, V _{IN} = 4.5V			38	mA

Note 1: All typicals are at V_{CC} = 5V, T_A = 25°C.

Note 2: Not more than one output should be shorted at a time, and the duration should not exceed one second.

Switching Characteristics at V_{CC} = 5V and T_A = 25°C

Symbol	Parameter	C _L = 15 pF		Units
		Min	Max	
t _{PLH} t _{PHL}	Propagation Delay Time A _n to a-g		100 100	ns
t _{PLH} t _{PHL}	Propagation Delay Time RB \bar{I} to a-f		100 100	ns

Note: \bar{T} = HIGH, A₀-A₃ = HIGH.

Numerical Designations—Resultant Displays

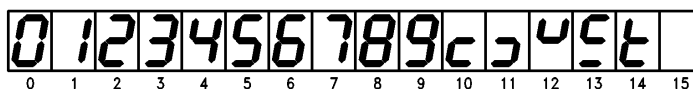

TL/F/10172-4

Truth Table

Decimal Or Function	Inputs						Outputs							
	\overline{LT}	\overline{RBI}	A ₃	A ₂	A ₁	A ₀	$\overline{BI/RBO}$	a	b	c	d	e	f	g
0 (Note 1)	H	H	L	L	L	L	H	H	H	H	H	H	H	L
1 (Note 1)	H	X	L	L	L	H	H	L	H	H	L	L	L	L
2	H	X	L	L	H	L	H	H	H	L	H	H	L	H
3	H	X	L	L	H	H	H	H	H	H	H	L	L	H
4	H	X	L	H	L	L	H	L	H	H	L	L	H	H
5	H	X	L	H	L	H	H	H	L	H	H	L	H	H
6	H	X	L	H	H	L	H	L	L	H	H	H	H	H
7	H	X	L	H	H	H	H	H	H	H	L	L	L	L
8	H	X	H	L	L	L	H	H	H	H	H	H	H	H
9	H	X	H	L	L	H	H	H	H	H	L	L	H	H
10	H	X	H	L	H	L	H	L	L	L	H	H	L	H
11	H	X	H	L	H	H	H	L	L	H	H	L	L	H
12	H	X	H	H	L	L	H	L	H	L	L	L	H	H
13	H	X	H	H	L	H	H	H	L	L	H	L	H	H
14	H	X	H	H	H	L	H	L	L	L	H	H	H	H
15	H	X	H	H	H	H	H	L	L	L	L	L	L	L
\overline{BI} (Note 2)	X	X	X	X	X	X	L	L	L	L	L	L	L	L
\overline{RBI} (Note 3)	H	L	L	L	L	L	L	L	L	L	L	L	L	L
\overline{LT} (Note 4)	L	X	X	X	X	X	H	H	H	H	H	H	H	H

Note 1: $\overline{BI/RBO}$ is wired-AND logic serving as blanking input (\overline{BI}) and/or ripple-blanking output (\overline{RBO}). The blanking out (\overline{BI}) must be open or held at a HIGH level when output functions 0 through 15 are desired, and ripple-blanking input (\overline{RBI}) must be open or at a HIGH level if blanking of a decimal 0 is not desired. X = input may be HIGH or LOW.

Note 2: When a LOW level is applied to the blanking input (forced condition) all segment outputs go to a LOW level, regardless of the state of any other input condition.

Note 3: When ripple-blanking input (\overline{RBI}) and inputs A₀, A₁, A₂, and A₃ are at LOW level, with the lamp test input at HIGH level, all segment outputs go to a LOW level and the ripple-blanking output (\overline{RBO}) goes to a LOW level (response condition).

Note 4: When the blanking input/ripple-blanking output ($\overline{BI/RBO}$) is open or held at a HIGH level, and a LOW level is applied to lamp test input, all segment outputs go to a HIGH level.

Logic Symbol

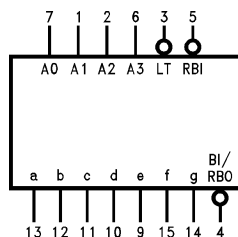

TL/F/10172-2

V_{CC} = Pin 16
GND = Pin 8

Logic Diagram

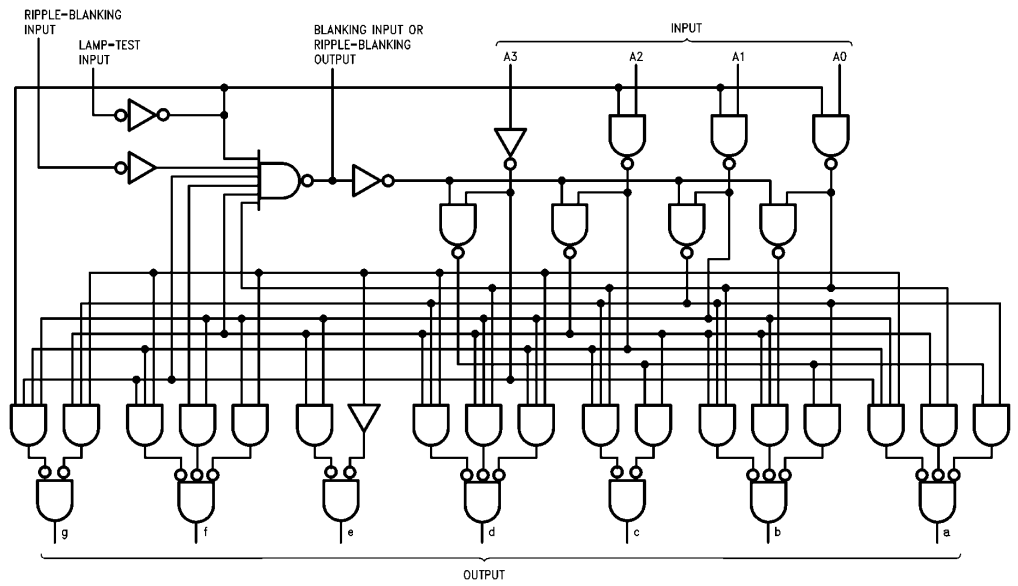

TL/F/10172-3

Physical Dimensions inches (millimeters)

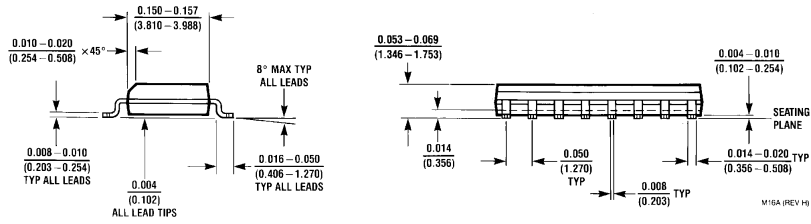
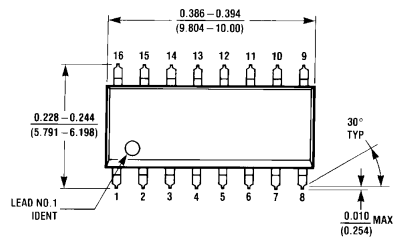

16-Lead Small Outline Molded Package (M)
Order Number DM74LS48M
NS Package Number M16A

Physical Dimensions inches (millimeters) (Continued)

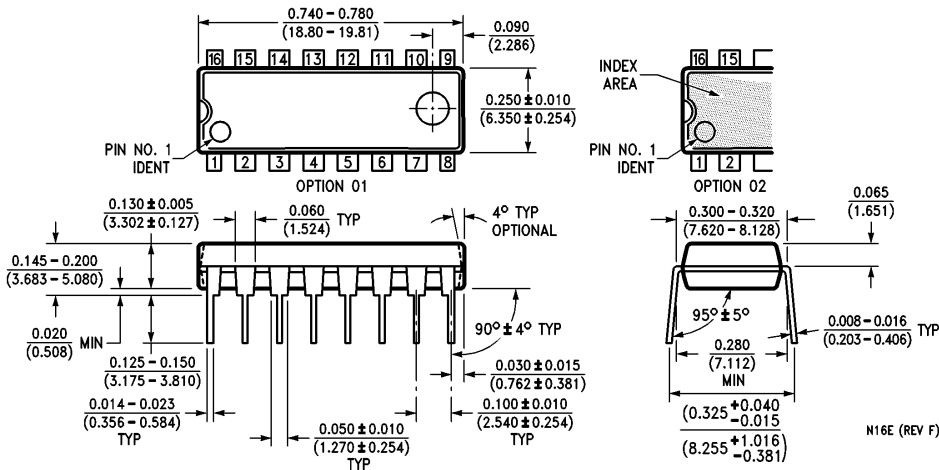

16-Lead Molded Dual-In-Line Package (N)
Order Number DM74LS48N
NS Package Number N16E

N16E (REV F)

LIFE SUPPORT POLICY

NATIONAL'S PRODUCTS ARE NOT AUTHORIZED FOR USE AS CRITICAL COMPONENTS IN LIFE SUPPORT DEVICES OR SYSTEMS WITHOUT THE EXPRESS WRITTEN APPROVAL OF THE PRESIDENT OF NATIONAL SEMICONDUCTOR CORPORATION. As used herein:

1. Life support devices or systems are devices or systems which, (a) are intended for surgical implant into the body, or (b) support or sustain life, and whose failure to perform, when properly used in accordance with instructions for use provided in the labeling, can be reasonably expected to result in a significant injury to the user.
2. A critical component is any component of a life support device or system whose failure to perform can be reasonably expected to cause the failure of the life support device or system, or to affect its safety or effectiveness.



National Semiconductor Corporation
 1111 West Bardin Road
 Arlington, TX 76017
 Tel: 1(800) 272-9959
 Fax: 1(800) 737-7018

National Semiconductor Europe
 Fax: (+49) 0-180-530 85 86
 Email: cnjwge@tevm2.nsc.com
 Deutsch Tel: (+49) 0-180-530 85 85
 English Tel: (+49) 0-180-532 78 32
 Français Tel: (+49) 0-180-532 93 58
 Italiano Tel: (+49) 0-180-534 16 80

National Semiconductor Hong Kong Ltd.
 19th Floor, Straight Block,
 Ocean Centre, 5 Canton Rd.
 Tsimshatsui, Kowloon
 Hong Kong
 Tel: (852) 2737-1600
 Fax: (852) 2736-9960

National Semiconductor Japan Ltd.
 Tel: 81-043-299-2309
 Fax: 81-043-299-2408

National does not assume any responsibility for use of any circuitry described, no circuit patent licenses are implied and National reserves the right at any time without notice to change said circuitry and specifications.