

DM74S157 • DM74S158

Quad 1 of 2 Line Data Selector/Multiplexer

General Description

These data selectors/multiplexers contain inverters and drivers to supply full on-chip data selection to the four output gates. A separate strobe input is provided. A 4-bit word is selected from one of two sources and is routed to the four outputs. The DM74S157 presents true data whereas the DM74S158 presents inverted data to minimize propagation delay time.

Applications

- Expand any data input point
- Multiplex dual data buses
- Generate four functions of two variables (one variable is common)
- Source programmable counters

Features

- Buffered inputs and outputs
- Typical propagation time
 - DM74S157 5 ns
 - DM74S158 4 ns
- Typical power dissipation
 - DM74S157 250 mW
 - DM74S158 195 mW

Ordering Code:

Order Number	Package Number	Package Description
DM74S157N	N16E	16-Lead Plastic Dual-In-Line Package (PDIP), JEDEC MS-001, 0.300 Wide
DM74S158N	N16E	16-Lead Plastic Dual-In-Line Package (PDIP), JEDEC MS-001, 0.300 Wide

Connection Diagrams

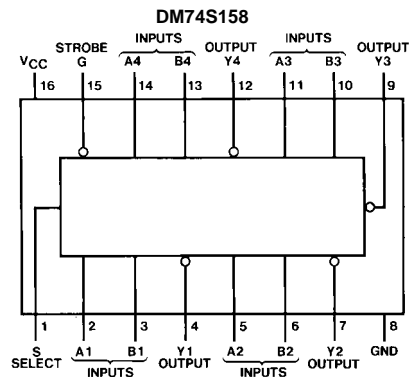
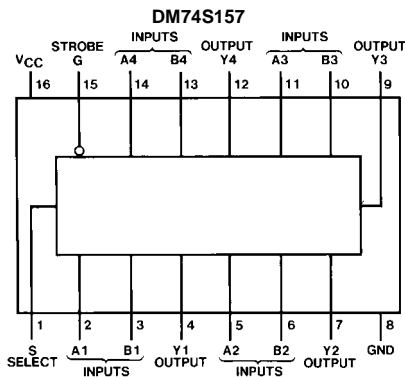

Function Table

Strobe	Inputs			Output Y	
	Select	A	B	DM74S157	DM74S158
H	X	X	X	L	H
L	L	L	X	L	H
L	L	H	X	H	L
L	H	X	L	L	H
L	H	X	H	H	L

H = HIGH Level
 L = LOW Level
 X = Don't Care

Logic Diagrams

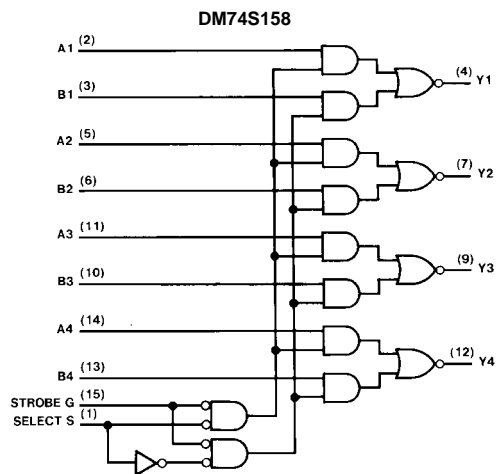
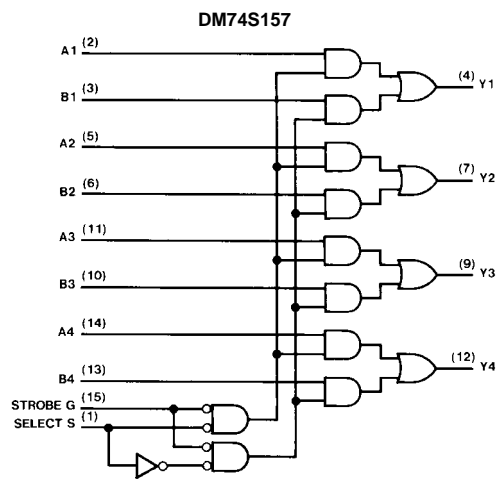

Absolute Maximum Ratings(Note 1)

Supply Voltage	7V
Input Voltage	5.5V
Operating Free Air Temperature Range	0°C to +70°C
Storage Temperature Range	-65°C to +150°C

Note 1: The "Absolute Maximum Ratings" are those values beyond which the safety of the device cannot be guaranteed. The device should not be operated at these limits. The parametric values defined in the Electrical Characteristics tables are not guaranteed at the absolute maximum ratings. The "Recommended Operating Conditions" table will define the conditions for actual device operation.

DM74157 Recommended Operating Conditions

Symbol	Parameter	Min	Nom	Max	Units
V_{CC}	Supply Voltage	4.75	5	5.25	V
V_{IH}	HIGH Level Input Voltage	2			V
V_{IL}	LOW Level Input Voltage			0.8	V
I_{OH}	HIGH Level Output Current			-1	mA
I_{OL}	LOW Level Output Current			20	mA
T_A	Free Air Operating Temperature	0		70	°C

DM74S157 Electrical Characteristics

over recommended operating free air temperature (unless otherwise noted)

Symbol	Parameter	Conditions	Min	Typ (Note 2)	Max	Units
V_I	Input Clamp Voltage	$V_{CC} = \text{Min}, I_I = -18 \text{ mA}$			-1.2	V
V_{OH}	HIGH Level Output Voltage	$V_{CC} = \text{Min}, I_{OH} = \text{Max}$ $V_{IL} = \text{Max}, V_{IH} = \text{Min}$	2.7	3.4		V
V_{OL}	LOW Level Output Voltage	$V_{CC} = \text{Min}, I_{OL} = \text{Max}$ $V_{IH} = \text{Min}, V_{IL} = \text{Max}$			0.5	V
I_I	Input Current @ Max Input Voltage	$V_{CC} = \text{Max}, V_I = 5.5\text{V}$			1	mA
I_{IH}	HIGH Level Input Current	$V_{CC} = \text{Max}$ $V_I = 2.7\text{V}$	S or G		100	μA
			A or B		50	
I_{IL}	HIGH Level Input Current	$V_{CC} = \text{Max}$ $V_I = 0.5\text{V}$	S or G		-4	mA
			A or B		-2	
I_{OS}	Short Circuit Output Current	$V_{CC} = \text{Max}$ (Note 3)	-40		-100	mA
I_{CC}	Supply Current	$V_{CC} = \text{Max}$ (Note 4)		50	78	mA

Note 2: All typicals are at $V_{CC} = 5\text{V}, T_A = 25^\circ\text{C}$.

Note 3: Not more than one output should be shorted at a time, and the duration should not exceed one second.

Note 4: I_{CC} is measured 4.5V applied to all inputs and all outputs OPEN.

DM74S157 Switching Characteristics

at $V_{CC} = 5\text{V}$ and $T_A = 25^\circ\text{C}$

Symbol	Parameter	From (Input) To (Output)	$R_L = 280\Omega$				Units
			$C_L = 15 \text{ pF}$		$C_L = 50 \text{ pF}$		
			Min	Max	Min	Max	
t_{PLH}	Propagation Delay Time LOW-to-HIGH Level Output	Data to Y		7.5		10	ns
t_{PHL}	Propagation Delay Time HIGH-to-LOW Level Output	Data to Y		6.5		10	ns
t_{PLH}	Propagation Delay Time LOW-to-HIGH Level Output	Strobe to Y		12.5		15	ns
t_{PHL}	Propagation Delay Time HIGH-to-LOW Level Output	Strobe to Y		12		15	ns
t_{PLH}	Propagation Delay Time LOW-to-HIGH Level Output	Select to Y		15		17	ns
t_{PHL}	Propagation Delay Time HIGH-to-LOW Level Output	Select to Y		15		17	ns

DM74S158 Recommended Operating Conditions

Symbol	Parameter	Min	Nom	Max	Units
V_{CC}	Supply Voltage	4.75	5	5.25	V
V_{IH}	HIGH Level Input Voltage	2			V
V_{IL}	LOW Level Input Voltage			0.8	V
I_{OH}	HIGH Level Output Current			-1	mA
I_{OL}	LOW Level Output Current			20	mA
T_A	Free Air Operating Temperature	0		70	°C

DM74S158 Electrical Characteristics

over recommended operating free air temperature (unless otherwise noted)

Symbol	Parameter	Conditions	Min	Typ (Note 5)	Max	Units
V_I	Input Clamp Voltage	$V_{CC} = \text{Min}, I_I = -18 \text{ mA}$			-1.2	V
V_{OH}	HIGH Level Output Voltage	$V_{CC} = \text{Min}, I_{OH} = \text{Max}$ $V_{IL} = \text{Max}, V_{IH} = \text{Min}$	2.7	3.4		V
V_{OL}	LOW Level Output Voltage	$V_{CC} = \text{Min}, I_{OL} = \text{Max}$ $V_{IH} = \text{Min}, V_{IL} = \text{Max}$			0.5	V
I_I	Input Current @ Max Input Voltage	$V_{CC} = \text{Max}, V_I = 5.5\text{V}$			1	mA
I_{IH}	HIGH Level Input Current	$V_{CC} = \text{Max}$ $V_I = 2.7\text{V}$	S or G		100	μA
			A or B		50	
I_{IL}	LOW Level Input Current	$V_{CC} = \text{Max}$ $V_I = 0.5\text{V}$	S or G		-4	mA
			A or B		-2	
I_{OS}	Short Circuit Output Current	$V_{CC} = \text{Max}$ (Note 6)	-40		-100	mA
I_{CC1}	Supply Current	$V_{CC} = \text{Max}$ (Note 7)		39	61	mA
I_{CC2}	Supply Current	$V_{CC} = \text{Max}$ (Note 8)			81	mA

Note 5: All typicals are at $V_{CC} = 5\text{V}, T_A = 25^\circ\text{C}$.

Note 6: Not more than one output should be shorted at a time, and the duration should not exceed one second.

Note 7: I_{CC1} is measured with all outputs OPEN and all inputs at 4.5V.

Note 8: I_{CC2} is measured with B, G, and S inputs grounded, A inputs at 4.5V, and all outputs OPEN.

DM74S158 Switching Characteristics

at $V_{CC} = 5\text{V}$ and $T_A = 25^\circ\text{C}$

Symbol	Parameter	From (Input) To (Output)	$R_L = 280\Omega$				Units
			$C_L = 15 \text{ pF}$		$C_L = 50 \text{ pF}$		
			Min	Max	Min	Max	
t_{PLH}	Propagation Delay Time LOW-to-HIGH Level Output	Data to Y		6		9	ns
t_{PHL}	Propagation Delay Time HIGH-to-LOW Level Output	Data to Y		6		9	ns
t_{PLH}	Propagation Delay Time LOW-to-HIGH Level Output	Strobe to Y		11.5		12	ns
t_{PHL}	Propagation Delay Time HIGH-to-LOW Level Output	Strobe to Y		12		14	ns
t_{PLH}	Propagation Delay Time LOW-to-HIGH Level Output	Select to Y		12		15	ns
t_{PHL}	Propagation Delay Time HIGH-to-LOW Level Output	Select to Y		12		15	ns

Physical Dimensions inches (millimeters) unless otherwise noted

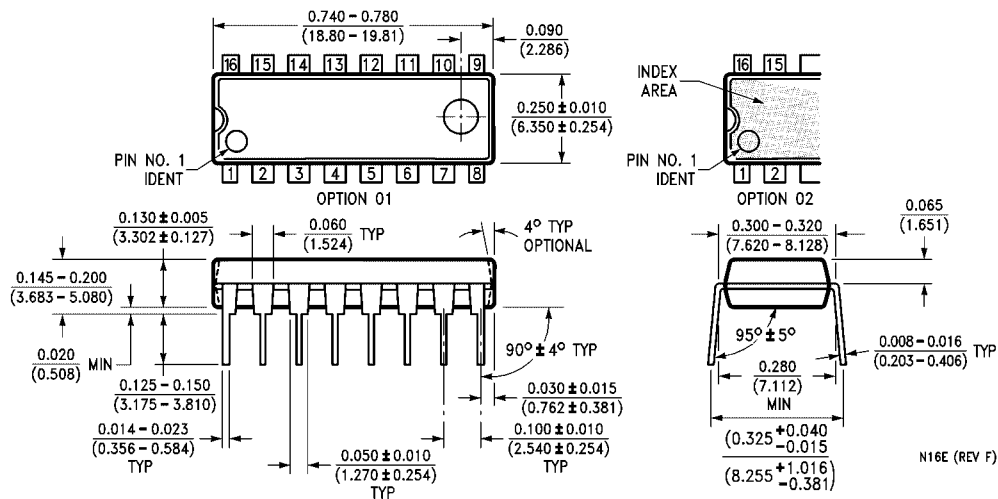

16-Lead Plastic Dual-In-Line Package (PDIP), JEDEC MS-001, 0.300 Wide Package Number N16E

Fairchild does not assume any responsibility for use of any circuitry described, no circuit patent licenses are implied and Fairchild reserves the right at any time without notice to change said circuitry and specifications.

LIFE SUPPORT POLICY

FAIRCHILD'S PRODUCTS ARE NOT AUTHORIZED FOR USE AS CRITICAL COMPONENTS IN LIFE SUPPORT DEVICES OR SYSTEMS WITHOUT THE EXPRESS WRITTEN APPROVAL OF THE PRESIDENT OF FAIRCHILD SEMICONDUCTOR CORPORATION. As used herein:

1. Life support devices or systems are devices or systems which, (a) are intended for surgical implant into the body, or (b) support or sustain life, and (c) whose failure to perform when properly used in accordance with instructions for use provided in the labeling, can be reasonably expected to result in a significant injury to the user.
2. A critical component in any component of a life support device or system whose failure to perform can be reasonably expected to cause the failure of the life support device or system, or to affect its safety or effectiveness.

www.fairchildsemi.com