

DATA SHEET

NE/SA/SE532

LM258/358/A/2904

Low power dual operational amplifiers

Product data
Supersedes data of 2002 Jan 22

2002 Jul 12

Low power dual operational amplifiers

**NE/SA/SE532/
LM258/358/A/2904**

DESCRIPTION

The 532/358/LM2904 consists of two independent, high gain, internally frequency-compensated operational amplifiers internally frequency-compensated operational amplifiers designed specifically to operate from a single power supply over a wide range of voltages. Operation from dual power supplies is also possible, and the low power supply current drain is independent of the magnitude of the power supply voltage.

UNIQUE FEATURES

In the linear mode the input common-mode voltage range includes ground and the output voltage can also swing to includes ground and the output voltage can also swing to ground, even though operated from only a single power supply voltage. The unity gain cross frequency is temperature-compensated. The input bias current is also temperature-compensated.

FEATURES

- Internally frequency-compensated for unity gain
- Large DC voltage gain: 100 dB
- Wide bandwidth (unity gain): 1 MHz (temperature-compensated)
- Wide power supply range single supply: $3 V_{DC}$ to $30 V_{DC}$, or dual supplies: $\pm 1.5 V_{DC}$ to $\pm 15 V_{DC}$
- Very low supply current drain ($400 \mu A$)—essentially independent of supply voltage ($1 mW/op amp$ at $+5 V_{DC}$)
- Low input biasing current: $45 nA_{DC}$ temperature-compensated
- Low input offset voltage: $2 mV_{DC}$, and offset current: $5 nA_{DC}$
- Differential input voltage range equal to the power supply voltage
- Large output voltage: $0 V_{DC}$ to $V+ 1.5 V_{DC}$ swing

PIN CONFIGURATION

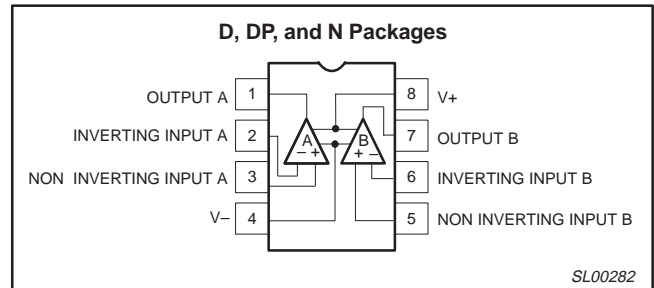

Figure 1. Pin configuration.

EQUIVALENT CIRCUIT

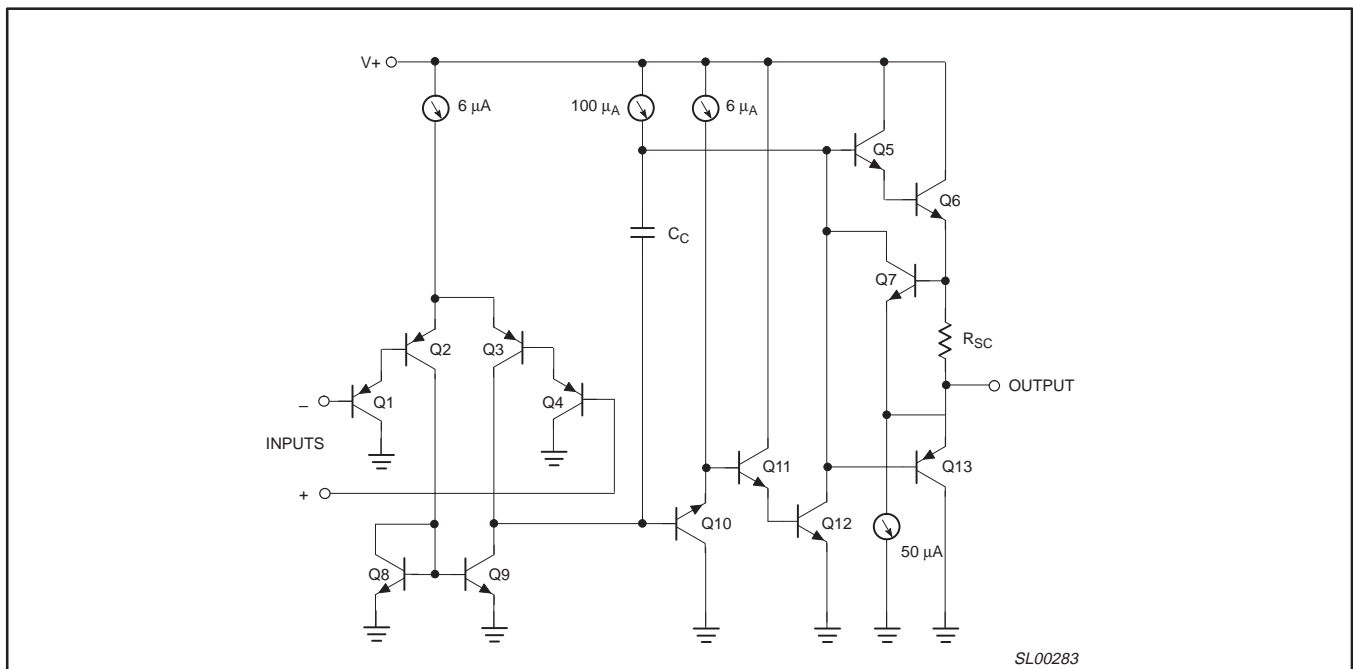

Figure 2. Equivalent circuit.

Low power dual operational amplifiers

NE/SA/SE532/
LM258/358/A/2904

ORDERING INFORMATION

DESCRIPTION	TEMPERATURE RANGE	ORDER CODE	DWG #
8-Pin Plastic Small Outline (SO) Package	0 °C to +70 °C	NE532D	SOT96-1
8-Pin Plastic Dual In-Line Package (DIP)	0 °C to +70 °C	NE532N	SOT97-1
8-Pin Plastic Small Outline (SO) Package	-40 °C to +85 °C	SA532D	SOT96-1
8-Pin Plastic Small Outline (SO) Package	-40 °C to +125 °C	LM2904D	SOT96-1
8-Pin Plastic Thin Shrink Small Outline Package (TSSOP)	-40 °C to +125 °C	LM2904DP	SOT505-1
8-Pin Plastic Dual In-Line Package (DIP)	-40 °C to +125 °C	LM2904N	SOT97-1
8-Pin Plastic Small Outline (SO) Package	-25 °C to +125 °C	LM258D	SOT96-1
8-Pin Plastic Dual In-Line Package (DIP)	-25 °C to +125 °C	LM258N	SOT97-1
8-Pin Plastic Small Outline (SO) Package	0 °C to +70 °C	LM358D	SOT96-1
8-Pin Plastic Thin Shrink Small Outline Package (TSSOP)	0 °C to +70 °C	LM358DP	SOT505-1
8-Pin Plastic Dual In-Line Package (DIP)	0 °C to +70 °C	LM358N	SOT97-1
8-Pin Plastic Small Outline (SO) Package	0 °C to +70 °C	LM358AD	SOT96-1
8-Pin Plastic Dual In-Line Package (DIP)	0 °C to +70 °C	LM358AN	SOT97-1
8-Pin Plastic Dual In-Line Package (DIP)	-55 °C to +125 °C	SE532N	SOT97-1

ABSOLUTE MAXIMUM RATINGS

SYMBOL	PARAMETER	RATING	UNIT
V_S	Supply voltage, V+	32 or ± 16	V_{DC}
	Differential input voltage	32	V_{DC}
V_{IN}	Input voltage	-0.3 to +32	V_{DC}
P_D	Maximum power dissipation $T_{amb} = 25\text{ °C}$ (Still air) ¹ N package D package DP package	1160 780 714	mW mW mW
	Output short-circuit to GND ² $V_+ < 15 V_{DC}$ and $T_{amb} = 25\text{ °C}$	Continuous	
T_{amb}	Operating ambient temperature range NE532/LM358/LM358A LM258 LM2904 SA532 SE532	0 to +70 -25 to +85 -40 to +125 -40 to +85 -55 to +125	°C °C °C °C °C
T_{stg}	Storage temperature range	-65 to +150	°C
T_{sld}	Lead soldering temperature (10 sec max)	230	°C

NOTE:

- Derate above 25 °C, at the following rates:
N package at 9.3 mW/°C
D package at 6.2 mW/°C
DP package at 5.72 mW/°C
- Short-circuits from the output to V+ can cause excessive heating and eventual destruction. The maximum output current is approximately 40 mA independent of the magnitude of V+. At values of supply voltage in excess of +15 V_{DC} , continuous short-circuits can exceed the power dissipation ratings and cause eventual destruction.

Low power dual operational amplifiers

NE/SA/SE532/
LM258/358/A/2904**DC ELECTRICAL CHARACTERISTICS** $T_{amb} = 25\text{ }^{\circ}\text{C}$; $V_{+} = +5\text{ V}$, unless otherwise specified.

SYMBOL	PARAMETER	TEST CONDITIONS	SE532, LM258			NE/SA532/ LM358/LM2904			UNIT
			Min	Typ	Max	Min	Typ	Max	
V_{OS}	Offset voltage ¹	$R_S = 0\ \Omega$		± 2	± 5		± 2	± 7	mV
		$R_S = 0\ \Omega$; over temp.			± 7			± 9	mV
V_{OS}	Drift	$R_S = 0\ \Omega$; over temp.		7			7		$\mu\text{V}/^{\circ}\text{C}$
I_{OS}	Offset current	$I_{IN(+)} - I_{IN(-)}$		± 3	± 30		± 5	± 50	nA
		Over temp.			± 100			± 150	nA
I_{OS}	Drift	Over temp.		10			10		$\text{pA}/^{\circ}\text{C}$
I_{BIAS}	Input current ²	$I_{IN(+)}$ or $I_{IN(-)}$		45	150		45	250	nA
		$I_{IN(+)}$ or $I_{IN(-)}$; Over temp.		40	300		40	500	nA
I_B	Drift	Over temp.		50			50		$\text{pA}/^{\circ}\text{C}$
V_{CM}	Common-mode voltage range ³	$V_{+} = 30\text{ V}$	0		$V_{+} - 1.5$	0		$V_{+} - 1.5$	V
		$V_{+} = 30\text{ V}$; Over temp.	0		$V_{+} - 2.0$	0		$V_{+} - 2.0$	V
CMRR	Common-mode rejection ratio	$V_{+} = 30\text{ V}$	70	85		65	70		dB
V_{OH}	Output voltage swing	$R_L \geq 2\text{ k}\Omega$; $V_{+} = 30\text{ V}$; over temp.	26			26			V
		$R_L \geq 10\text{ k}\Omega$; $V_{+} = 30\text{ V}$; over temp.	27	28		27	28		V
V_{OL}	Output voltage swing	$R_L \geq 10\text{ k}\Omega$; over temp.		5	20		5	20	mV
I_{CC}	Supply current	$R_L = \infty$; $V_{+} = 30\text{ V}$		0.5	1.0		0.5	1.0	mA
		$R_L = \infty$ on all amplifiers; $V_{+} = 30\text{ V}$; over temp.		0.6	1.2		0.6	1.2	mA
A_{VOL}	Large-signal voltage gain	$R_L \geq 2\text{ k}\Omega$; $V_{OUT} \pm 10\text{ V}$	50	100		25	100		V/mV
		$V_{+} = 15\text{ V}$ (for large V_O swing); over temp.	25			15			V/mV
PSRR	Supply voltage rejection ratio	$R_S = 0\ \Omega$	65	100		65	100		dB
	Amplifier-to-amplifier coupling ⁴	$f = 1\text{ kHz to } 20\text{ kHz}$ (input referred)		-120			-120		dB
I_{OUT}	Output current (Source)	$V_{IN+} = +1\text{ V}_{DC}$; $V_{IN-} = 0\text{ V}_{DC}$; $V_{+} = 15\text{ V}_{DC}$	20	40		20	40		mA
		$V_{IN+} = +1\text{ V}_{DC}$; $V_{IN-} = 0\text{ V}_{DC}$; $V_{+} = 15\text{ V}_{DC}$; over temp.	10	20		10	20		mA
	Output current (Sink)	$V_{IN-} = +1\text{ V}_{DC}$; $V_{IN+} = 0\text{ V}_{DC}$; $V_{+} = 15\text{ V}_{DC}$	10	20		10	20		mA
		$V_{IN-} = +1\text{ V}_{DC}$; $V_{IN+} = 0\text{ V}_{DC}$; $V_{+} = 15\text{ V}_{DC}$; over temp.	5	8		5	8		mA
		$V_{IN+} = 0\text{ V}$; $V_{IN-} = +1\text{ V}_{DC}$; $V_O = 200\text{ mV}$	12	50		12	50		μA
I_{SC}	Short circuit current ⁵		40	60		40	60	mA	
	Differential input voltage ⁶			V_{+}			V_{+}	V	
GBW	Unity gain bandwidth	$T_{amb} = 25\text{ }^{\circ}\text{C}$		1			1		MHz
SR	Slew rate	$T_{amb} = 25\text{ }^{\circ}\text{C}$		0.3			0.3		$\text{V}/\mu\text{s}$
V_{NOISE}	Input noise voltage	$T_{amb} = 25\text{ }^{\circ}\text{C}$; $f = 1\text{ kHz}$		40			40		$\text{nV}/\sqrt{\text{Hz}}$

(Notes on next page).

Low power dual operational amplifiers

NE/SA/SE532/
LM258/358/A/2904**DC ELECTRICAL CHARACTERISTICS** (continued) $T_{amb} = 25\text{ }^{\circ}\text{C}$; $V_+ = +5\text{ V}$; unless otherwise specified.

SYMBOL	PARAMETER	TEST CONDITIONS	LM358A			UNIT
			Min	Typ	Max	
V_{OS}	Offset voltage ¹	$R_S = 0\ \Omega$		± 2	± 3	mV
		$R_S = 0\ \Omega$; over temp.			± 5	mV
V_{OS}	Drift	$R_S = 0\ \Omega$; over temp.		7	20	$\mu\text{V}/^{\circ}\text{C}$
I_{OS}	Offset current	$I_{IN(+)} - I_{IN(-)}$		5	± 30	nA
		Over temp.			± 75	nA
I_{OS}	Drift	Over temp.		10	300	$\text{pA}/^{\circ}\text{C}$
I_{BIAS}	Input current ²	$I_{IN(+)} \text{ or } I_{IN(-)}$		45	100	nA
		$I_{IN(+)} \text{ or } I_{IN(-)}$; Over temp.		40	200	nA
I_B	Drift	Over temp.		50		$\text{pA}/^{\circ}\text{C}$
V_{CM}	Common-mode voltage range ³	$V_+ = 30\text{ V}$	0		$V_+ - 1.5$	V
		$V_+ = 30\text{ V}$; Over temp.	0		$V_+ - 2.0$	V
CMRR	Common-mode rejection ratio	$V_+ = 30\text{ V}$	65	85		dB
V_{OH}	Output voltage swing	$R_L \geq 2\text{ k}\Omega$; $V_+ = 30\text{ V}$; over temp.	26			V
		$R_L \geq 10\text{ k}\Omega$; $V_+ = 30\text{ V}$; over temp.	27	28		V
V_{OL}	Output voltage swing	$R_L \geq 10\text{ k}\Omega$; over temp.		5	20	mV
I_{CC}	Supply current	$R_L = \infty$, $V_+ = 30\text{ V}$		0.5	1.0	mA
		$R_L = \infty$ on all amplifiers; $V_+ = 30\text{ V}$; over temp.		0.6	1.2	mA
A_{VOL}	Large-signal voltage gain	$R_L \geq 2\text{ k}\Omega$; $V_{OUT} \pm 10\text{ V}$	25	100		V/mV
		$V_+ = 15\text{ V}$ (for large V_O swing); over temp.	15			V/mV
PSRR	Supply voltage rejection ratio	$R_S = 0\ \Omega$	65	100		dB
	Amplifier-to-amplifier coupling ⁴	$f = 1\text{ kHz to } 20\text{ kHz}$ (input referred)		-120		dB
I_{OUT}	Output current (Source)	$V_{IN+} = +1\text{ V}_{DC}$; $V_{IN-} = 0\text{ V}_{DC}$; $V_+ = 15\text{ V}_{DC}$	20	40		mA
		$V_{IN+} = +1\text{ V}_{DC}$; $V_{IN-} = 0\text{ V}_{DC}$; $V_+ = 15\text{ V}_{DC}$; over temp.	10	20		mA
	Output current (Sink)	$V_{IN-} = +1\text{ V}_{DC}$; $V_{IN+} = 0\text{ V}_{DC}$; $V_+ = 15\text{ V}_{DC}$	10	20		mA
		$V_{IN-} = +1\text{ V}_{DC}$; $V_{IN+} = 0\text{ V}_{DC}$; $V_+ = 15\text{ V}_{DC}$; over temp.	5	8		mA
		$V_{IN+} = 0\text{ V}$; $V_{IN-} = +1\text{ V}_{DC}$; $V_O = 200\text{ mV}$	12	50		μA
I_{SC}	Short circuit current ⁵		40	60		mA
	Differential input voltage ⁶			V_+		V
GBW	Unity gain bandwidth	$T_{amb} = 25\text{ }^{\circ}\text{C}$		1		MHz
SR	Slew rate	$T_{amb} = 25\text{ }^{\circ}\text{C}$		0.3		V/ μs
V_{NOISE}	Input noise voltage	$T_{amb} = 25\text{ }^{\circ}\text{C}$; $f = 1\text{ kHz}$		40		nV/ $\sqrt{\text{Hz}}$

NOTES:

- $V_O \approx 1.4\text{ V}$, $R_S = 0\ \Omega$ with V_+ from 5 V to 30 V ; and over the full input common-mode range (0 V to $V_+ - 1.5\text{ V}$).
- The direction of the input current is out of the IC due to the PNP input stage. This current is essentially constant, independent of the state of the output so no loading change exists on the input lines.
- The input common-mode voltage or either input signal voltage should not be allowed to go negative by more than 0.3 V . The upper end of the common-mode voltage range is $V_+ - 1.5\text{ V}$, but either or both inputs can go to $+32\text{ V}$ without damage.
- Due to proximity of external components, insure that coupling is not originating via stray capacitance between these external parts. This typically can be detected as this type of capacitance coupling increases at higher frequencies.
- Short-circuits from the output to V_+ can cause excessive heating and eventual destruction. The maximum output current is approximately 40 mA independent of the magnitude of V_+ . At values of supply voltage in excess of $+15\text{ V}_{DC}$, continuous short-circuits can exceed the power dissipation ratings and cause eventual destruction.
- The input common-mode voltage or either input signal voltage should not be allowed to go negative by more than 0.3 V . The upper end of the common-mode voltage range is $V_+ - 1.5\text{ V}$, but either or both inputs can go to $+32\text{ V}_{DC}$ without damage.

Low power dual operational amplifiers

NE/SA/SE532/
LM258/358/A/2904

TYPICAL PERFORMANCE CHARACTERISTICS

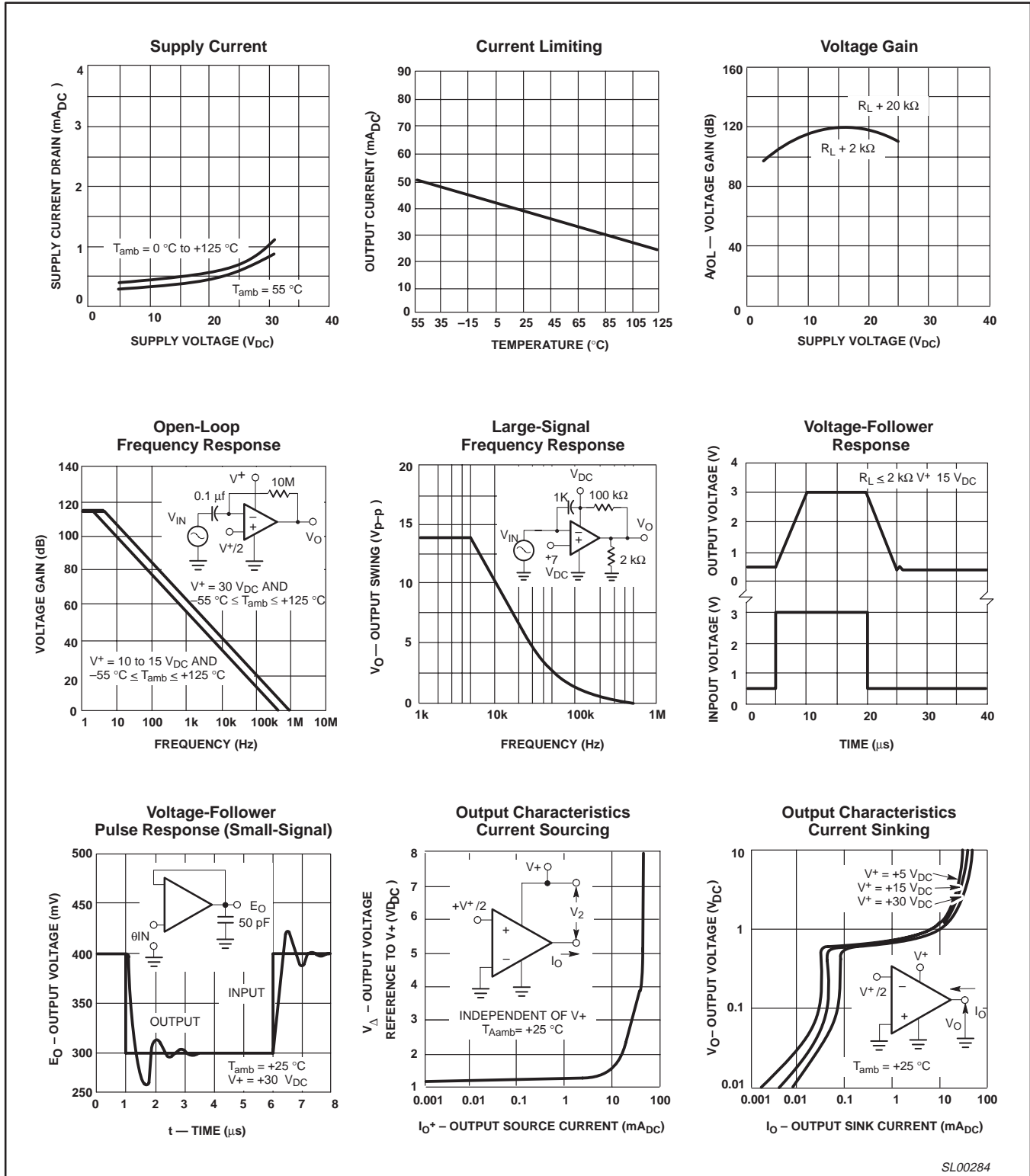

Figure 3. Typical performance characteristics.

Low power dual operational amplifiers

NE/SA/SE532/
LM258/358/A/2904

TYPICAL PERFORMANCE CHARACTERISTICS (Continued)

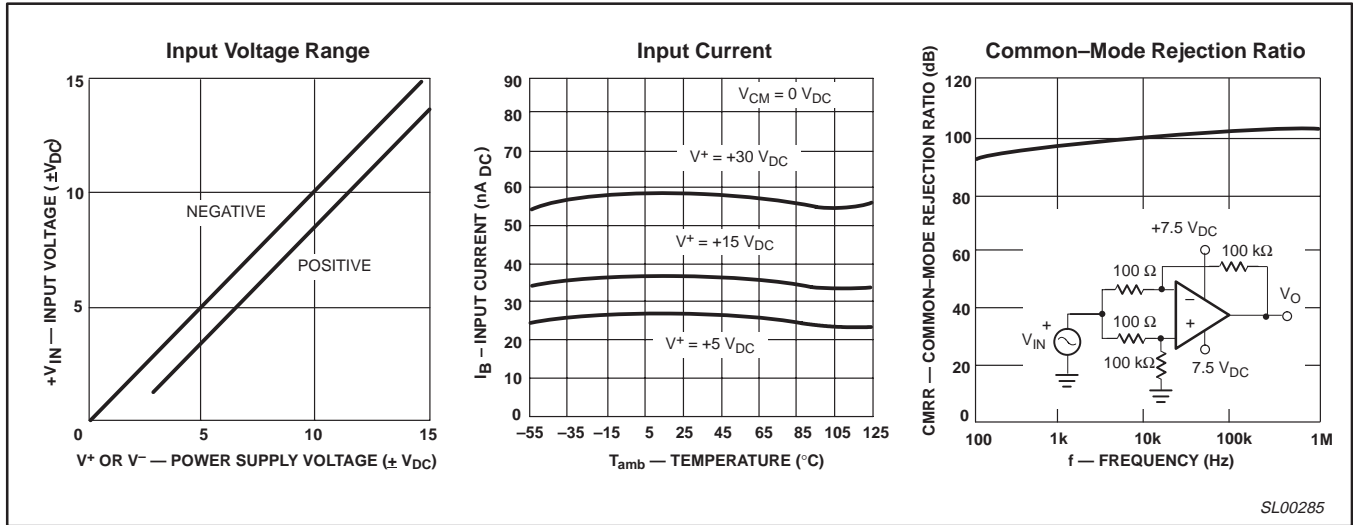

Figure 4. Typical performance characteristics (continued).

TYPICAL APPLICATIONS

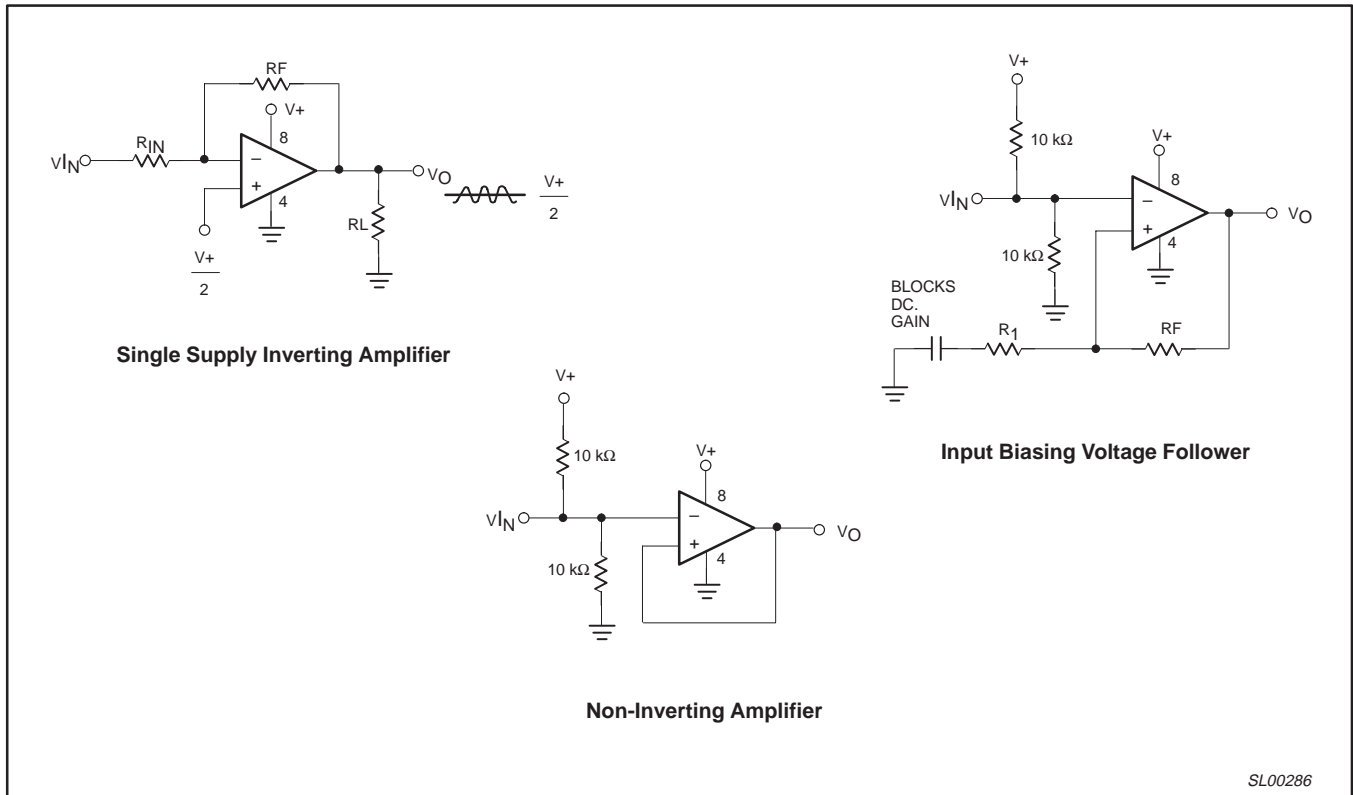

Figure 5. Typical applications.

Low power dual operational amplifiers

NE/SA/SE532/
LM258/358/A/2904

S08: plastic small outline package; 8 leads; body width 3.9 mm

SOT96-1

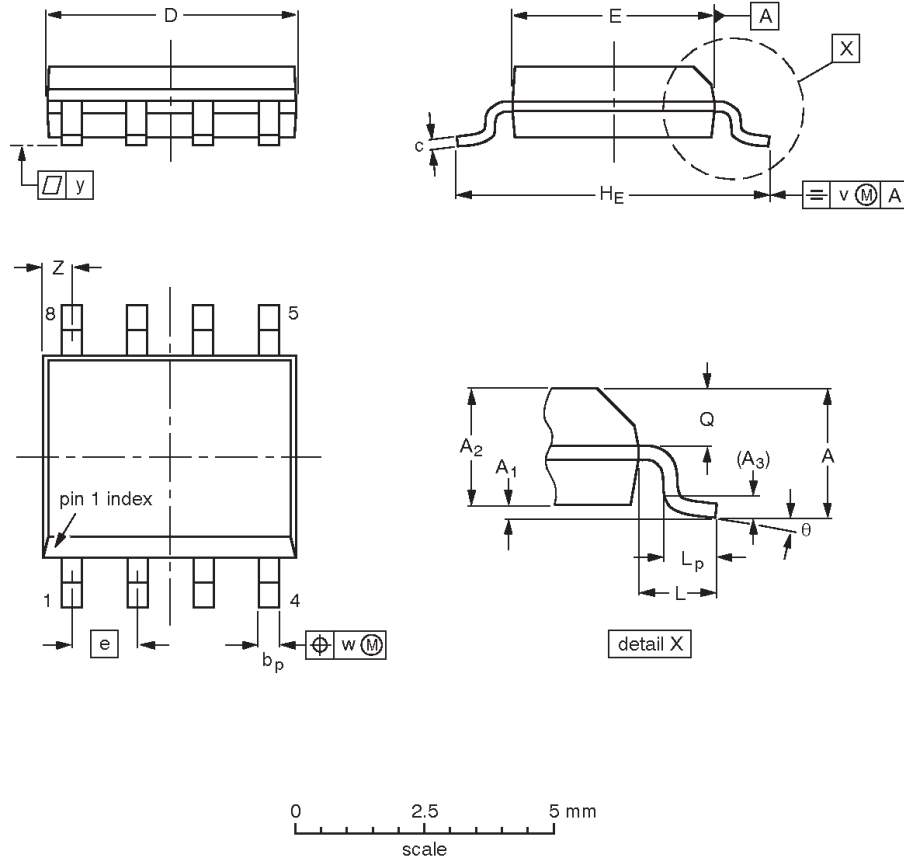

DIMENSIONS (inch dimensions are derived from the original mm dimensions)

UNIT	A max.	A ₁	A ₂	A ₃	b _p	c	D ⁽¹⁾	E ⁽²⁾	e	H _E	L	L _p	Q	v	w	y	Z ⁽¹⁾	θ
mm	1.75	0.25 0.10	1.45 1.25	0.25	0.49 0.36	0.25 0.19	5.0 4.8	4.0 3.8	1.27	6.2 5.8	1.05	1.0 0.4	0.7 0.6	0.25	0.25	0.1	0.7 0.3	8° 0°
inches	0.069	0.010 0.004	0.057 0.049	0.01	0.019 0.014	0.0100 0.0075	0.20 0.19	0.16 0.15	0.050	0.244 0.228	0.041	0.039 0.016	0.028 0.024	0.01	0.01	0.004	0.028 0.012	

Notes

1. Plastic or metal protrusions of 0.15 mm maximum per side are not included.
2. Plastic or metal protrusions of 0.25 mm maximum per side are not included.

OUTLINE VERSION	REFERENCES				EUROPEAN PROJECTION	ISSUE DATE
	IEC	JEDEC	EIAJ			
SOT96-1	076E03	MS-012				97-05-22- 99-12-27

Low power dual operational amplifiers

NE/SA/SE532/
LM258/358/A/2904

DIP8: plastic dual in-line package; 8 leads (300 mil)

SOT97-1

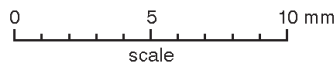
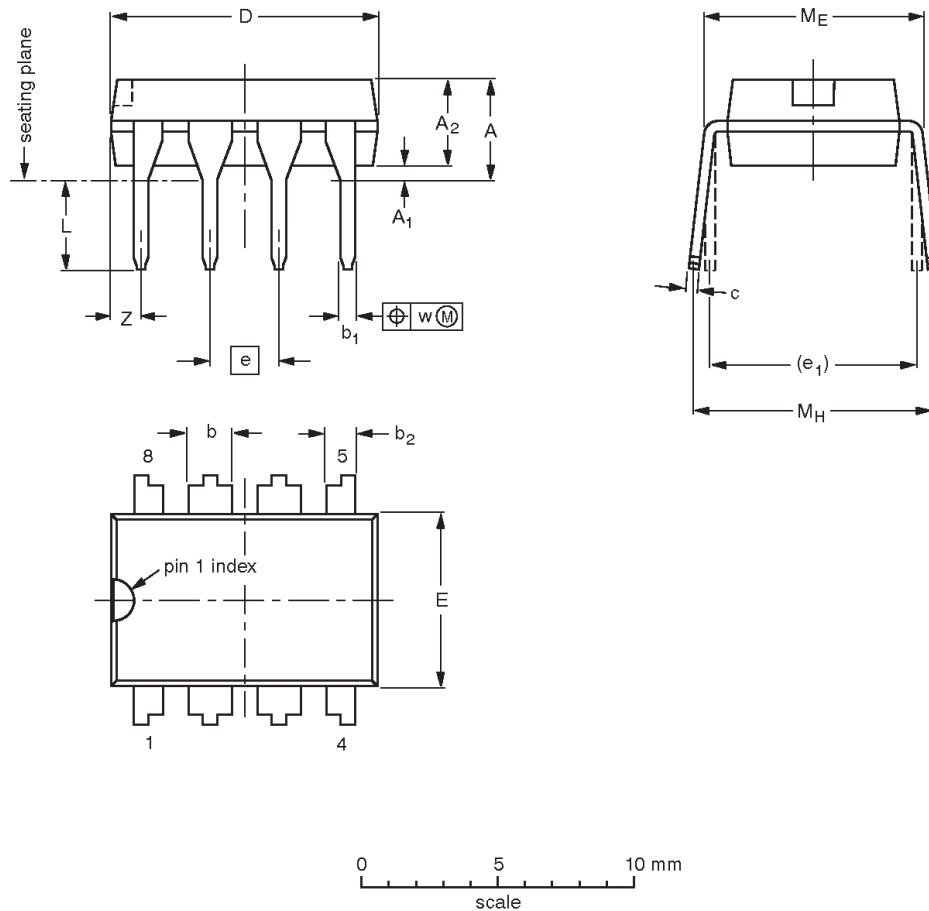

DIMENSIONS (inch dimensions are derived from the original mm dimensions)

UNIT	A max.	A ₁ min.	A ₂ max.	b	b ₁	b ₂	c	D ⁽¹⁾	E ⁽¹⁾	e	e ₁	L	M _E	M _H	w	Z ⁽¹⁾ max.
mm	4.2	0.51	3.2	1.73 1.14	0.53 0.38	1.07 0.89	0.36 0.23	9.8 9.2	6.48 6.20	2.54	7.62	3.60 3.05	8.25 7.80	10.0 8.3	0.254	1.15
inches	0.17	0.020	0.13	0.068 0.045	0.021 0.015	0.042 0.035	0.014 0.009	0.39 0.36	0.26 0.24	0.10	0.30	0.14 0.12	0.32 0.31	0.39 0.33	0.01	0.045

Note

1. Plastic or metal protrusions of 0.25 mm maximum per side are not included.

OUTLINE VERSION	REFERENCES				EUROPEAN PROJECTION	ISSUE DATE
	IEC	JEDEC	EIAJ			
SOT97-1	050G01	MO-001	SC-504-8			95-02-04 99-12-27

Low power dual operational amplifiers

NE/SA/SE532/
LM258/358/A/2904

TSSOP8: plastic thin shrink small outline package; 8 leads; body width 3 mm

SOT505-1

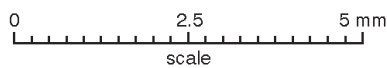
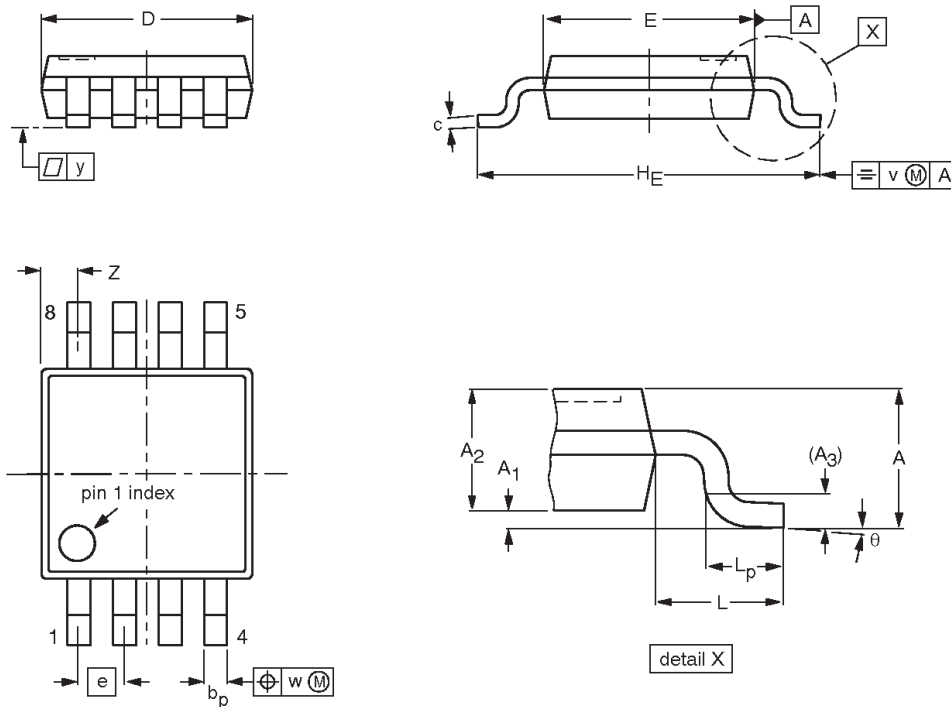

DIMENSIONS (mm are the original dimensions)

UNIT	A max.	A ₁	A ₂	A ₃	b _p	c	D ⁽¹⁾	E ⁽²⁾	e	H _E	L	L _p	v	w	y	Z ⁽¹⁾	θ
mm	1.10	0.15 0.05	0.95 0.80	0.25	0.45 0.25	0.28 0.15	3.10 2.90	3.10 2.90	0.65	5.10 4.70	0.94	0.70 0.40	0.1	0.1	0.1	0.70 0.35	6° 0°

Notes

1. Plastic or metal protrusions of 0.15 mm maximum per side are not included.
2. Plastic or metal protrusions of 0.25 mm maximum per side are not included.

OUTLINE VERSION	REFERENCES				EUROPEAN PROJECTION	ISSUE DATE
	IEC	JEDEC	EIAJ			
SOT505-1						99-04-09

Low power dual operational amplifiers

NE/SA/SE532/
LM258/358/A/2904

NOTES

Low power dual operational amplifiers

NE/SA/SE532/
LM258/358/A/2904

Data sheet status

Data sheet status ^[1]	Product status ^[2]	Definitions
Objective data	Development	This data sheet contains data from the objective specification for product development. Philips Semiconductors reserves the right to change the specification in any manner without notice.
Preliminary data	Qualification	This data sheet contains data from the preliminary specification. Supplementary data will be published at a later date. Philips Semiconductors reserves the right to change the specification without notice, in order to improve the design and supply the best possible product.
Product data	Production	This data sheet contains data from the product specification. Philips Semiconductors reserves the right to make changes at any time in order to improve the design, manufacturing and supply. Changes will be communicated according to the Customer Product/Process Change Notification (CPCN) procedure SNW-SQ-650A.

[1] Please consult the most recently issued data sheet before initiating or completing a design.

[2] The product status of the device(s) described in this data sheet may have changed since this data sheet was published. The latest information is available on the Internet at URL <http://www.semiconductors.philips.com>.

Definitions

Short-form specification — The data in a short-form specification is extracted from a full data sheet with the same type number and title. For detailed information see the relevant data sheet or data handbook.

Limiting values definition — Limiting values given are in accordance with the Absolute Maximum Rating System (IEC 60134). Stress above one or more of the limiting values may cause permanent damage to the device. These are stress ratings only and operation of the device at these or at any other conditions above those given in the Characteristics sections of the specification is not implied. Exposure to limiting values for extended periods may affect device reliability.

Application information — Applications that are described herein for any of these products are for illustrative purposes only. Philips Semiconductors make no representation or warranty that such applications will be suitable for the specified use without further testing or modification.

Disclaimers

Life support — These products are not designed for use in life support appliances, devices or systems where malfunction of these products can reasonably be expected to result in personal injury. Philips Semiconductors customers using or selling these products for use in such applications do so at their own risk and agree to fully indemnify Philips Semiconductors for any damages resulting from such application.

Right to make changes — Philips Semiconductors reserves the right to make changes, without notice, in the products, including circuits, standard cells, and/or software, described or contained herein in order to improve design and/or performance. Philips Semiconductors assumes no responsibility or liability for the use of any of these products, conveys no license or title under any patent, copyright, or mask work right to these products, and makes no representations or warranties that these products are free from patent, copyright, or mask work right infringement, unless otherwise specified.

Contact information

For additional information please visit
<http://www.semiconductors.philips.com>. Fax: +31 40 27 24825

© Koninklijke Philips Electronics N.V. 2002
All rights reserved. Printed in U.S.A.

Date of release: 08-02

For sales offices addresses send e-mail to:
sales.addresses@www.semiconductors.philips.com

Document order number:

9397 750 10187

Let's make things better.