



+5.0V、±15kV ESD保护、失效保护、热插拔、RS-485/RS-422收发器

MAX13080E-MAX13089E

概述

特性

MAX13080E-MAX13089E是+5.0V供电、具有±15kV ESD保护的RS-485/RS-422收发器，包含一路驱动器和一路接收器。这些器件具有失效保护电路，当接收器输入开路或短路时，确保接收器输出逻辑高电平。如果挂接在终端匹配总线上的所有发送器都禁用(高阻)，接收器将输出逻辑高电平。MAX13080E-MAX13089E具有热插拔功能，在上电或热插入时可以消除总线上的故障瞬变信号。

MAX13080E/MAX13081E/MAX13082E具有低摆率驱动器，能够减小EMI和由于不恰当的电缆端接所引起的反射，实现高达250kbps的无差错数据传输；MAX13083E/MAX13084E/MAX13085E具有限摆率驱动器，可实现高达500kbps的传输速率；MAX13086E/MAX13087E/MAX13088E驱动器的摆率不受限制，可实现高达16Mbps的传输速率；MAX13089E的摆率可以由引脚选择，以适应250kbps、500kbps和16Mbps的传输速率。

MAX13082E/MAX13085E/MAX13088E用于半双工通信；MAX13080E/MAX13081E/MAX13083E/MAX13084E/MAX13086E/MAX13087E用于全双工通信；MAX13089E可以设置为半双工或全双工通信，并具有独立的、可由引脚设置的接收器与发送器输出相位。

空载或驱动器禁用情况下，MAX13080E-MAX13089E收发器吸取1.2mA电源电流。所有器件的接收器具有1/8单位负载输入阻抗，总线上可以挂接多达256个收发器。

MAX13080E/MAX13083E/MAX13086E/MAX13089E采用14引脚PDIP和14引脚SO封装，MAX13081E/MAX13082E/MAX13084E/MAX13085E/MAX13087E/MAX13088E采用8引脚PDIP和8引脚SO封装。这些器件可以提供商用级、扩展工业级或汽车级温度范围。

- ◆ +5.0V工作电压
- ◆ 为RS-485/RS-422 I/O引脚提供增强型ESD保护 ±15kV人体模式
- ◆ 真正的失效保护接收器兼容于EIA/TIA-485
- ◆ DE与RE采用热插拔输入结构
- ◆ 强大的摆率控制功能有助于实现无差错数据传输 (MAX13080E-MAX13085E/MAX13089E)
- ◆ 低电流关断模式 (MAX13081E/MAX13084E/MAX13087E除外)
- ◆ 可通过引脚选择全双工/半双工模式(MAX13089E)
- ◆ 为纠正双绞线反接提供相位控制(MAX13089E)
- ◆ 总线上允许挂接多达256个收发器
- ◆ 提供工业标准的8引脚SO封装

订购信息

PART	TEMP RANGE	PIN-PACKAGE	PKG CODE
MAX13080ECPD	0°C to +70°C	14 PDIP	P14-3
MAX13080ECSO	0°C to +70°C	14 SO	S14-2
MAX13080EEPD	-40°C to +85°C	14 PDIP	P14-3
MAX13080EESD	-40°C to +85°C	14 SO	S14-2
MAX13080EAPD	-40°C to +125°C	14 PDIP	P14-3
MAX13080EASD	-40°C to +125°C	14 SO	S14-2

应用

- 三表
- 照明系统
- 工业控制
- 电信
- 安防系统
- 仪器仪表
- Profibus

订购信息(续)在数据资料的最后给出。

选型指南、引脚配置和典型工作电路在数据资料的最后给出。



+5.0V、±15kV ESD保护、失效保护、热插拔、RS-485/RS-422收发器

MAX13080E-MAX13089E

ABSOLUTE MAXIMUM RATINGS

(All Voltages Referenced to GND)

Supply Voltage (V _{CC}).....	+6V
Control Input Voltage (\overline{RE} , DE, SLR, H/ \overline{F} , TXP, RXP).....	-0.3V to +6V
Driver Input Voltage (DI).....	-0.3V to +6V
Driver Output Voltage (Z, Y, A, B).....	-8V to +13V
Receiver Input Voltage (A, B).....	-8V to +13V
Receiver Input Voltage Full Duplex (A, B).....	-8V to +13V
Receiver Output Voltage (RO).....	-0.3V to (V _{CC} + 0.3V)
Driver Output Current.....	±250mA

Continuous Power Dissipation (T_A = +70°C)

8-Pin SO (derate 5.88mW/°C above +70°C)	471mW
8-Pin Plastic DIP (derate 9.09mW/°C above +70°C)	727mW
14-Pin SO (derate 8.33mW/°C above +70°C)	667mW
14-Pin Plastic DIP (derate 10.0mW/°C above +70°C)	800mW

Operating Temperature Ranges

MAX1308_EC_ _	0°C to +75°C
MAX1308_EE_ _	-40°C to +85°C
MAX1308_EA_ _	-40°C to +125°C

Junction Temperature

Storage Temperature Range

Lead Temperature (soldering, 10s)

Stresses beyond those listed under "Absolute Maximum Ratings" may cause permanent damage to the device. These are stress ratings only, and functional operation of the device at these or any other conditions beyond those indicated in the operational sections of the specifications is not implied. Exposure to absolute maximum rating conditions for extended periods may affect device reliability.

DC ELECTRICAL CHARACTERISTICS

(V_{CC} = +5.0V ±10%, T_A = T_{MIN} to T_{MAX}, unless otherwise noted. Typical values are at V_{CC} = +5.0V and T_A = +25°C.) (Note 1)

PARAMETER	SYMBOL	CONDITIONS	MIN	TYP	MAX	UNITS
DRIVER						
V _{CC} Supply-Voltage Range	V _{CC}		4.5		5.5	V
Differential Driver Output	V _{OD}	R _L = 100Ω (RS-422), Figure 1	3		V _{CC}	V
		R _L = 54Ω (RS-485), Figure 1	2		V _{CC}	
		No load			V _{CC}	
Change in Magnitude of Differential Output Voltage	ΔV _{OD}	R _L = 100Ω or 54Ω, Figure 1 (Note 2)			0.2	V
Driver Common-Mode Output Voltage	V _{OC}	R _L = 100Ω or 54Ω, Figure 1		V _{CC} / 2	3	V
Change in Magnitude of Common-Mode Voltage	ΔV _{OC}	R _L = 100Ω or 54Ω, Figure 1 (Note 2)			0.2	V
Input-High Voltage	V _{IH}	DE, DI, \overline{RE} , TXP, RXP, H/ \overline{F}	3			V
Input-Low Voltage	V _{IL}	DE, DI, \overline{RE} , TXP, RXP, H/ \overline{F}			0.8	V
Input Hysteresis	V _{HYS}	DE, DI, \overline{RE} , TXP, RXP, H/ \overline{F}		100		mV
Input Current	I _{IN1}	DE, DI, \overline{RE}			±1	μA
Input Impedance First Transition		DE	1		10	kΩ
Input Current	I _{IN2}	TXP, RXP, H/ \overline{F} internal pull-down	10		40	μA
SRL Input-High Voltage			V _{CC} - 0.4			V
SRL Input-Middle Voltage			V _{CC} × 0.3	V _{CC} × 0.7		V
SRL Input-Low Voltage					0.4	V
SRL Input Current		SRL = V _{CC}			75	μA
		SRL = GND			-75	
Output Leakage (Y and Z) Full Duplex	I _O	DE = GND, V _{CC} = GND or V _{CC}	V _{IN} = +12V		125	μA
			V _{IN} = -7V	-100		

+5.0V、±15kV ESD保护、失效保护、热插拔、RS-485/RS-422收发器

MAX13080E-MAX13089E

DC ELECTRICAL CHARACTERISTICS (continued)

(V_{CC} = +5.0V ±10%, T_A = T_{MIN} to T_{MAX}, unless otherwise noted. Typical values are at V_{CC} = +5.0V and T_A = +25°C.) (Note 1)

PARAMETER	SYMBOL	CONDITIONS	MIN	TYP	MAX	UNITS
Driver Short-Circuit Output Current	I _{OSD}	0 ≤ V _{OUT} ≤ +12V (Note 3)	40		250	mA
		-7V ≤ V _{OUT} ≤ V _{CC} (Note 3)	-250		-40	
		0 ≤ V _{OUT} ≤ +12V, +85°C ≤ T _A ≤ +125°C (Note 3)	40		270	
		-7V ≤ V _{OUT} ≤ V _{CC} , +85°C ≤ T _A ≤ +125°C (Note 3)	-270		-40	
Driver Short-Circuit Foldback Output Current	I _{OSDF}	(V _{CC} - 1V) ≤ V _{OUT} ≤ +12V (Note 3)	20			mA
		-7V ≤ V _{OUT} ≤ +1V (Note 3)			-20	
Thermal-Shutdown Threshold	T _{TS}			175		°C
Thermal-Shutdown Hysteresis	T _{TSH}			15		°C
Input Current (A and B)	I _{A, B}	DE = GND, V _{CC} = GND or V _{CC}	V _{IN} = +12V		125	μA
			V _{IN} = -7V	-100		
RECEIVER						
Receiver Differential Threshold Voltage	V _{TH}	-7V ≤ V _{CM} ≤ +12V	-200	-125	-50	mV
Receiver Input Hysteresis	ΔV _{TH}	V _A + V _B = 0		15		mV
RO Output-High Voltage	V _{OH}	I _O = -1mA	V _{CC} - 0.6			V
RO Output-Low Voltage	V _{OL}	I _O = 1mA			0.4	V
Three-State Output Current at Receiver	I _{OZR}	0 ≤ V _O ≤ V _{CC}			± 1	μA
Receiver Input Resistance	R _{IN}	-7V ≤ V _{CM} ≤ +12V	96			kΩ
Receiver Output Short-Circuit Current	I _{OSR}	0V ≤ V _{RO} ≤ V _{CC}			±110	mA
SUPPLY CURRENT						
Supply Current	I _{CC}	No load, $\overline{RE} = 0$, DE = V _{CC}		1.2	1.8	mA
		No load, $\overline{RE} = V_{CC}$, DE = V _{CC}		1.2	1.8	
		No load, $\overline{RE} = 0$, DE = 0		1.2	1.8	
Supply Current in Shutdown Mode	I _{SHDN}	$\overline{RE} = V_{CC}$, DE = GND		2.8	10	μA
ESD PROTECTION						
ESD Protection for Y, Z, A, and B		Human Body Model		±15		kV
		Contact Discharge IEC 61000-4-2		±6		kV

+5.0V、±15kV ESD保护、失效保护、热插拔、RS-485/RS-422收发器

MAX13080E-MAX13089E

DRIVER SWITCHING CHARACTERISTICS

MAX13080E/MAX13081E/MAX13082E/MAX13089E WITH SRL = UNCONNECTED (250kbps)

(V_{CC} = +5.0V ±10%, T_A = T_{MIN} to T_{MAX}, unless otherwise noted. Typical values are at V_{CC} = +5.0V and T_A = +25°C.)

PARAMETER	SYMBOL	CONDITIONS	MIN	TYP	MAX	UNITS
Driver Propagation Delay	t _{DPLH}	C _L = 50pF, R _L = 54Ω, Figures 2 and 3	350		1800	ns
	t _{DPHL}		350		1800	
Driver Differential Output Rise or Fall Time	t _R , t _F	C _L = 50pF, R _L = 54Ω, Figures 2 and 3	400		1900	ns
Differential Driver Output Skew t _{DPLH} - t _{DPHL}	t _{DSKEW}	C _L = 50pF, R _L = 54Ω, Figures 2 and 3			250	ns
Maximum Data Rate			250			kbps
Driver Enable to Output High	t _{DZH}	Figure 4			2500	ns
Driver Enable to Output Low	t _{DZL}	Figure 5			2500	ns
Driver Disable Time from Low	t _{DLZ}	Figure 5			100	ns
Driver Disable Time from High	t _{DHZ}	Figure 4			100	ns
Driver Enable from Shutdown to Output High	t _{DZH(SHDN)}	Figure 4			5500	ns
Driver Enable from Shutdown to Output Low	t _{DZL(SHDN)}	Figure 5			5500	ns
Time to Shutdown	t _{SHDN}		50	340	700	ns

RECEIVER SWITCHING CHARACTERISTICS

MAX13080E/MAX13081E/MAX13082E/MAX13089E WITH SRL = UNCONNECTED (250kbps)

(V_{CC} = +5.0V ±10%, T_A = T_{MIN} to T_{MAX}, unless otherwise noted. Typical values are at V_{CC} = +5.0V and T_A = +25°C.)

PARAMETER	SYMBOL	CONDITIONS	MIN	TYP	MAX	UNITS
Receiver Propagation Delay	t _{RPLH}	C _L = 15pF, Figures 6 and 7			200	ns
	t _{RPHL}				200	
Receiver Output Skew t _{RPLH} - t _{RPHL}	t _{RSKEW}	C _L = 15pF, Figures 6 and 7			30	ns
Maximum Data Rate			250			kbps
Receiver Enable to Output Low	t _{RZL}	Figure 8			50	ns
Receiver Enable to Output High	t _{RZH}	Figure 8			50	ns
Receiver Disable Time from Low	t _{RLZ}	Figure 8			50	ns
Receiver Disable Time from High	t _{RHZ}	Figure 8			50	ns
Receiver Enable from Shutdown to Output High	t _{RZH(SHDN)}	Figure 8			5500	ns
Receiver Enable from Shutdown to Output Low	t _{RZL(SHDN)}	Figure 8			5500	ns
Time to Shutdown	t _{SHDN}		50	340	700	ns

+5.0V、±15kV ESD保护、失效保护、热插拔、RS-485/RS-422收发器

MAX13080E-MAX13089E

DRIVER SWITCHING CHARACTERISTICS

MAX13083E/MAX13084E/MAX13085E/MAX13089E WITH SRL = V_{CC} (500kbps)

(V_{CC} = +5.0V ±10%, T_A = T_{MIN} to T_{MAX}, unless otherwise noted. Typical values are at V_{CC} = +5.0V and T_A = +25°C.)

PARAMETER	SYMBOL	CONDITIONS	MIN	TYP	MAX	UNITS
Driver Propagation Delay	t _{DPLH}	C _L = 50pF, R _L = 54Ω, Figures 2 and 3	200		1000	ns
	t _{DPHL}		200		1000	
Driver Differential Output Rise or Fall Time	t _R , t _F	C _L = 50pF, R _L = 54Ω, Figures 2 and 3	250		900	ns
Differential Driver Output Skew t _{DPLH} - t _{DPHL}	t _{DSKEW}	C _L = 50pF, R _L = 54Ω, Figures 2 and 3			140	ns
Maximum Data Rate			500			kbps
Driver Enable to Output High	t _{DZH}	Figure 4			2500	ns
Driver Enable to Output Low	t _{DZL}	Figure 5			2500	ns
Driver Disable Time from Low	t _{DLZ}	Figure 5			100	ns
Driver Disable Time from High	t _{DHZ}	Figure 4			100	ns
Driver Enable from Shutdown to Output High	t _{DZH(SHDN)}	Figure 4			5500	ns
Driver Enable from Shutdown to Output Low	t _{DZL(SHDN)}	Figure 5			5500	ns
Time to Shutdown	t _{SHDN}		50	340	700	ns

RECEIVER SWITCHING CHARACTERISTICS

MAX13083E/MAX13084E/MAX13085E/MAX13089E WITH SRL = V_{CC} (500kbps)

(V_{CC} = +5.0V ±10%, T_A = T_{MIN} to T_{MAX}, unless otherwise noted. Typical values are at V_{CC} = +5.0V and T_A = +25°C.)

PARAMETER	SYMBOL	CONDITIONS	MIN	TYP	MAX	UNITS
Receiver Propagation Delay	t _{RPLH}	C _L = 15pF, Figures 6 and 7			200	ns
	t _{RPHL}				200	
Receiver Output Skew t _{RPLH} - t _{RPHL}	t _{RSKEW}	C _L = 15pF, Figures 6 and 7			30	ns
Maximum Data Rate			500			kbps
Receiver Enable to Output Low	t _{RZL}	Figure 8			50	ns
Receiver Enable to Output High	t _{RZH}	Figure 8			50	ns
Receiver Disable Time from Low	t _{RLZ}	Figure 8			50	ns
Receiver Disable Time from High	t _{RHZ}	Figure 8			50	ns
Receiver Enable from Shutdown to Output High	t _{RZH(SHDN)}	Figure 8			5500	ns
Receiver Enable from Shutdown to Output Low	t _{RZL(SHDN)}	Figure 8			5500	ns
Time to Shutdown	t _{SHDN}		50	340	700	ns

+5.0V、±15kV ESD保护、失效保护、热插拔、RS-485/RS-422收发器

MAX13080E-MAX13089E

DRIVER SWITCHING CHARACTERISTICS

MAX13086E/MAX13087E/MAX13088E/MAX13089E WITH SRL = GND (16Mbps)

($V_{CC} = +5.0V \pm 10\%$, $T_A = T_{MIN}$ to T_{MAX} , unless otherwise noted. Typical values are at $V_{CC} = +5.0V$ and $T_A = +25^\circ C$.)

PARAMETER	SYMBOL	CONDITIONS	MIN	TYP	MAX	UNITS
Driver Propagation Delay	t_{DPLH}	$C_L = 50pF$, $R_L = 54\Omega$, Figures 2 and 3	50			ns
	t_{DPHL}		50			
Driver Differential Output Rise or Fall Time	t_R , t_F	$C_L = 50pF$, $R_L = 54\Omega$, Figures 2 and 3	15			ns
Differential Driver Output Skew $ t_{DPLH} - t_{DPHL} $	t_{DSKEW}	$C_L = 50pF$, $R_L = 54\Omega$, Figures 2 and 3	8			ns
Maximum Data Rate			16			Mbps
Driver Enable to Output High	t_{DZH}	Figure 4	150			ns
Driver Enable to Output Low	t_{DZL}	Figure 5	150			ns
Driver Disable Time from Low	t_{DLZ}	Figure 5	100			ns
Driver Disable Time from High	t_{DHZ}	Figure 4	100			ns
Driver Enable from Shutdown to Output High	$t_{DZH(SHDN)}$	Figure 4	2200			ns
Driver Enable from Shutdown to Output Low	$t_{DZL(SHDN)}$	Figure 5	2200			ns
Time to Shutdown	t_{SHDN}		50	340	700	ns

RECEIVER SWITCHING CHARACTERISTICS

MAX13086E/MAX13087E/MAX13088E/MAX13089E WITH SRL = GND (16Mbps)

($V_{CC} = +5.0V \pm 10\%$, $T_A = T_{MIN}$ to T_{MAX} , unless otherwise noted. Typical values are at $V_{CC} = +5.0V$ and $T_A = +25^\circ C$.)

PARAMETER	SYMBOL	CONDITIONS	MIN	TYP	MAX	UNITS
Receiver Propagation Delay	t_{RPLH}	$C_L = 15pF$, Figures 6 and 7	50			ns
	t_{RPHL}		80			
Receiver Output Skew $ t_{RPLH} - t_{RPHL} $	t_{RSKEW}	$C_L = 15pF$, Figures 6 and 7	13			ns
Maximum Data Rate			16			Mbps
Receiver Enable to Output Low	t_{RZL}	Figure 8	50			ns
Receiver Enable to Output High	t_{RZH}	Figure 8	50			ns
Receiver Disable Time from Low	t_{RLZ}	Figure 8	50			ns
Receiver Disable Time from High	t_{RHZ}	Figure 8	50			ns
Receiver Enable from Shutdown to Output High	$t_{RZH(SHDN)}$	Figure 8	2200			ns
Receiver Enable from Shutdown to Output Low	$t_{RZL(SHDN)}$	Figure 8	2200			ns
Time to Shutdown	t_{SHDN}		50	340	700	ns

Note 1: All currents into the device are positive. All currents out of the device are negative. All voltages are referred to device ground, unless otherwise noted.

Note 2: ΔV_{OD} and ΔV_{OC} are the changes in V_{OD} and V_{OC} , respectively, when the DI input changes state.

Note 3: The short-circuit output current applies to peak current just prior to foldback current limiting. The short-circuit foldback output current applies during current limiting to allow a recovery from bus contention.

+5.0V、±15kV ESD保护、失效保护、热插拔、RS-485/RS-422收发器

典型工作特性

($V_{CC} = +5.0V$, $T_A = +25^\circ C$, unless otherwise noted.)

MAX13080E-MAX13089E

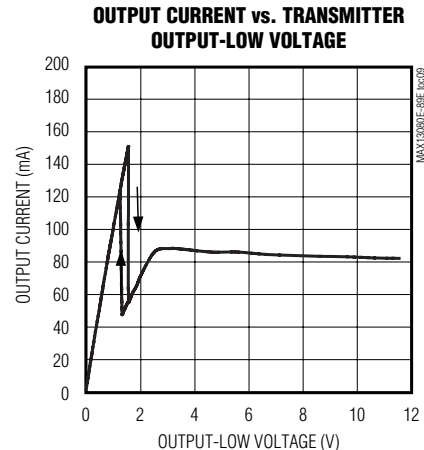
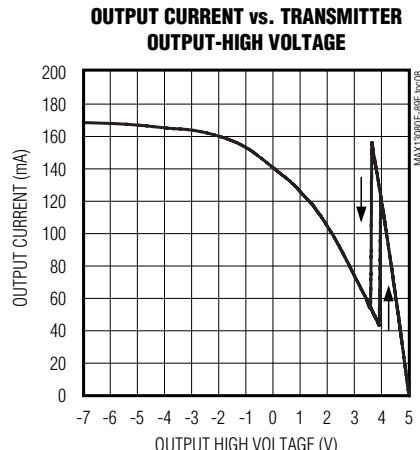
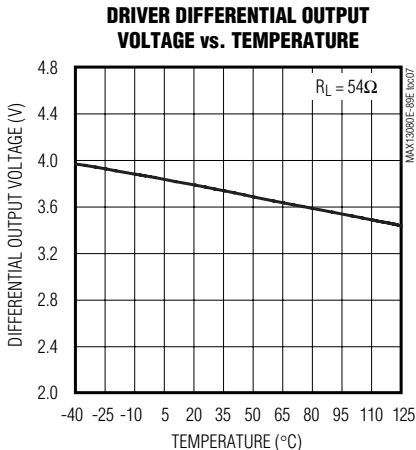
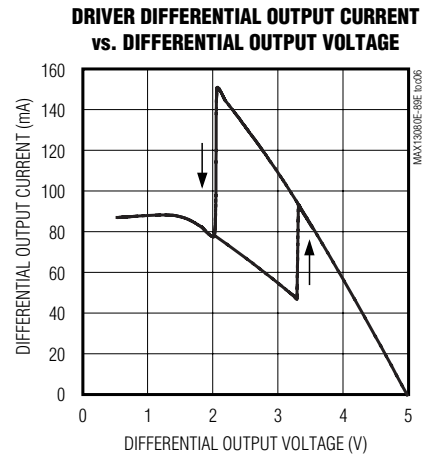
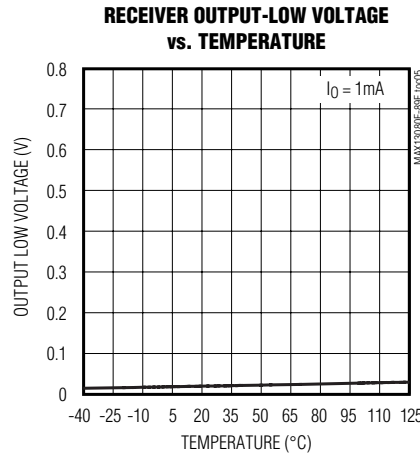
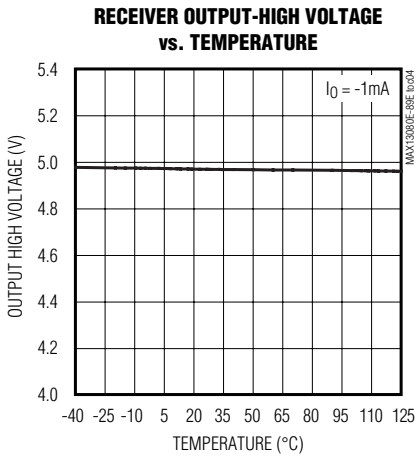
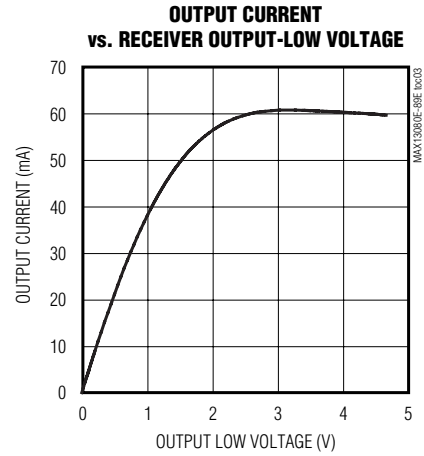
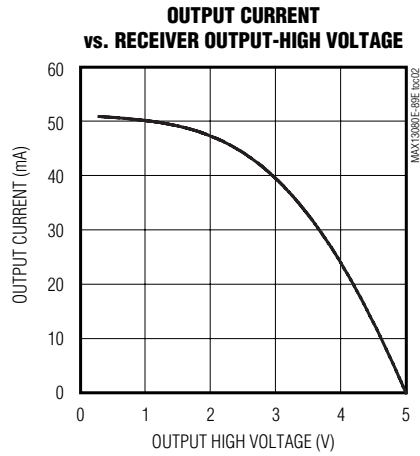
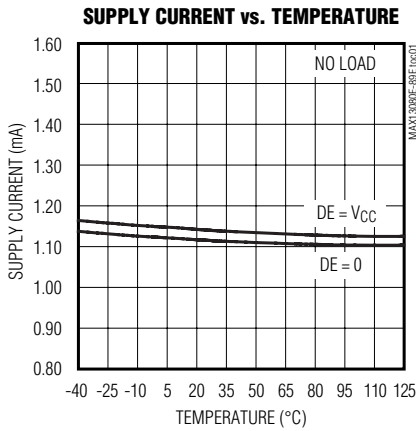

+5.0V、±15kV ESD保护、失效保护、热插拔、RS-485/RS-422收发器

MAX13080E-MAX13089E

典型工作特性(续)

(VCC = +5.0V, TA = +25°C, unless otherwise noted.)

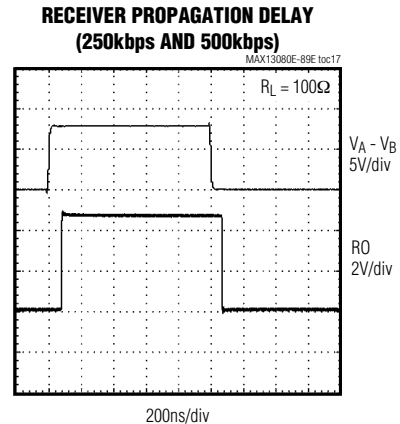
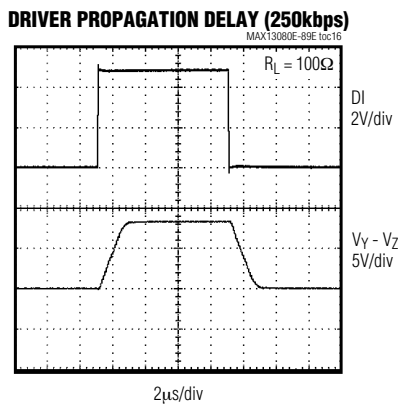
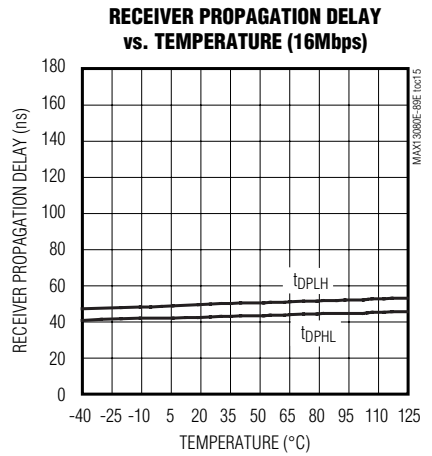
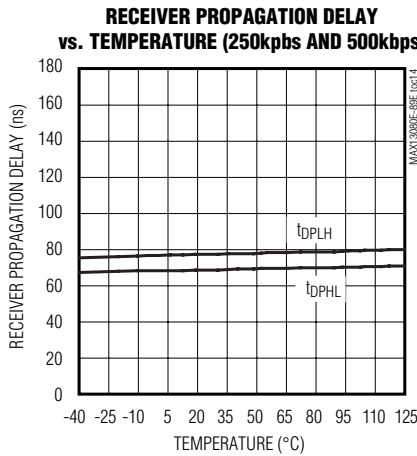
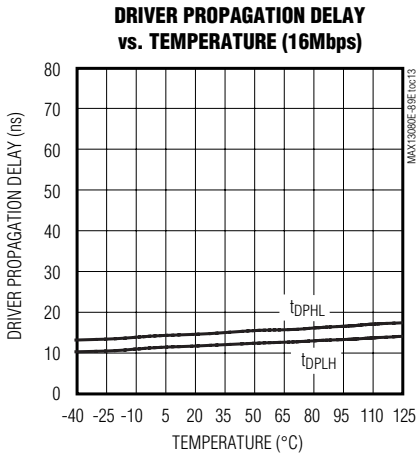
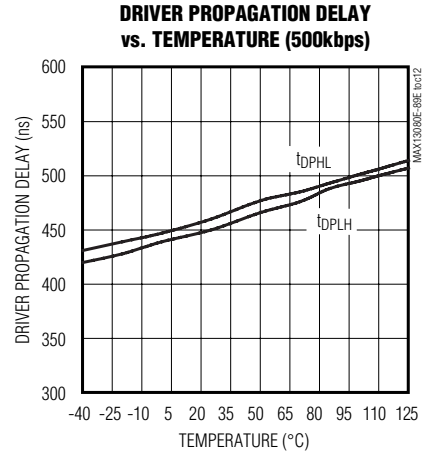
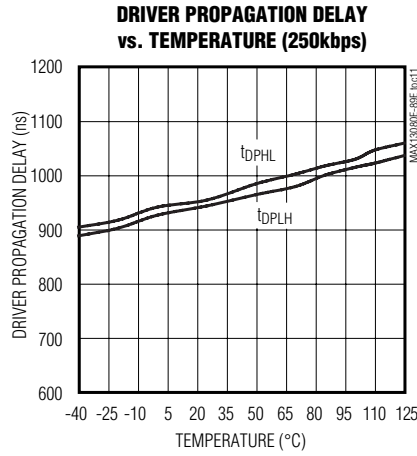
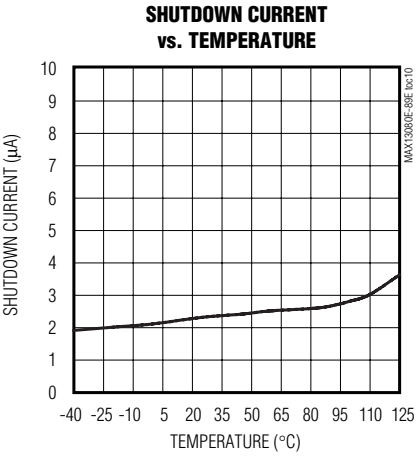

+5.0V、±15kV ESD保护、失效保护、热插拔、RS-485/RS-422收发器

典型工作特性(续)

($V_{CC} = +5.0V$, $T_A = +25^{\circ}C$, unless otherwise noted.)

DRIVER PROPAGATION DELAY (500kbps)

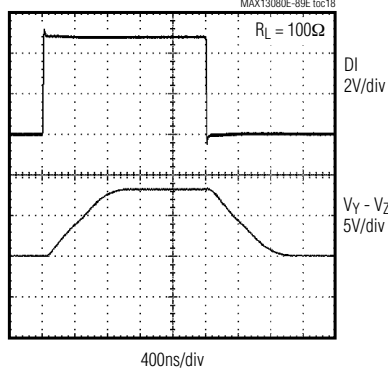

DRIVER PROPAGATION DELAY (16Mbps)

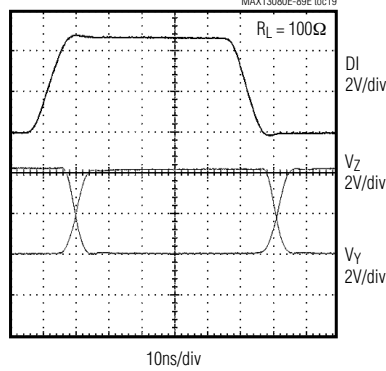

RECEIVER PROPAGATION DELAY (16Mbps)

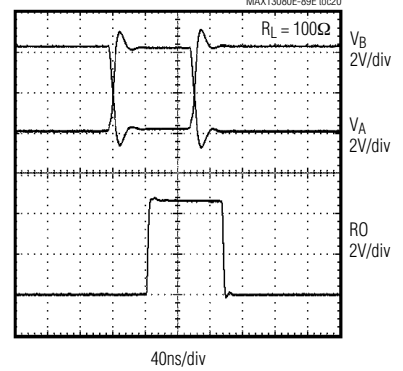

测试电路与波形



图1. 驱动器DC测试负载



图3. 驱动器传输延时

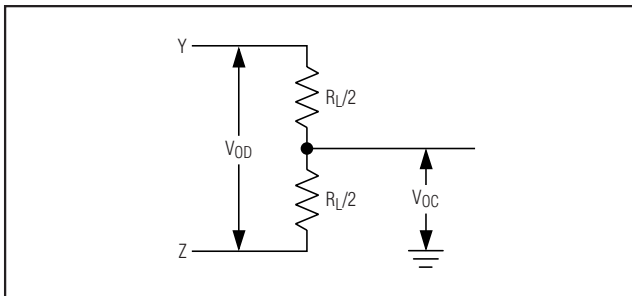

图2. 驱动器时序测试电路

+5.0V、±15kV ESD保护、失效保护、热插拔、RS-485/RS-422收发器

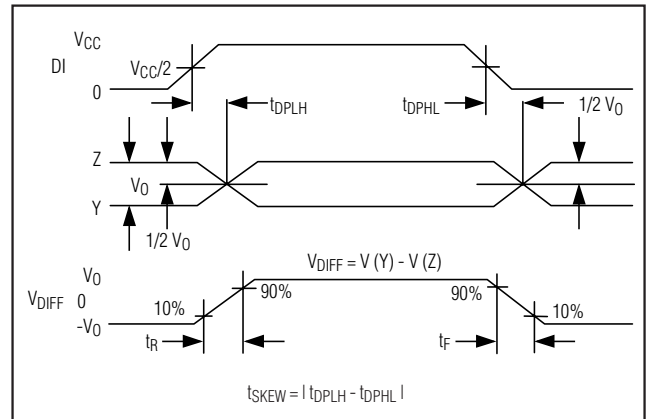
MAX13080E-MAX13089E

测试电路与波形(续)

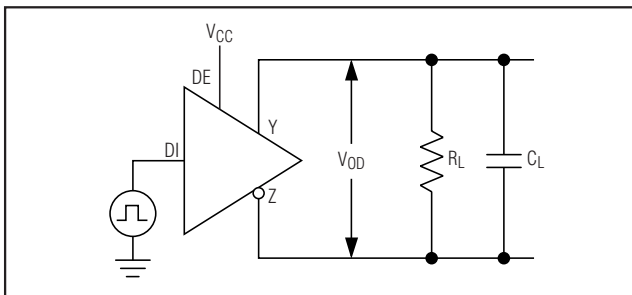

图4. 驱动器使能和禁用时序(t_{DZH} 、 $t_{DZH(SHDN)}$)



图5. 驱动器使能和禁用时序(t_{DLZ} 、 $t_{DLZ(SHDN)}$)

+5.0V、±15kV ESD保护、失效保护、 热插拔、RS-485/RS-422收发器

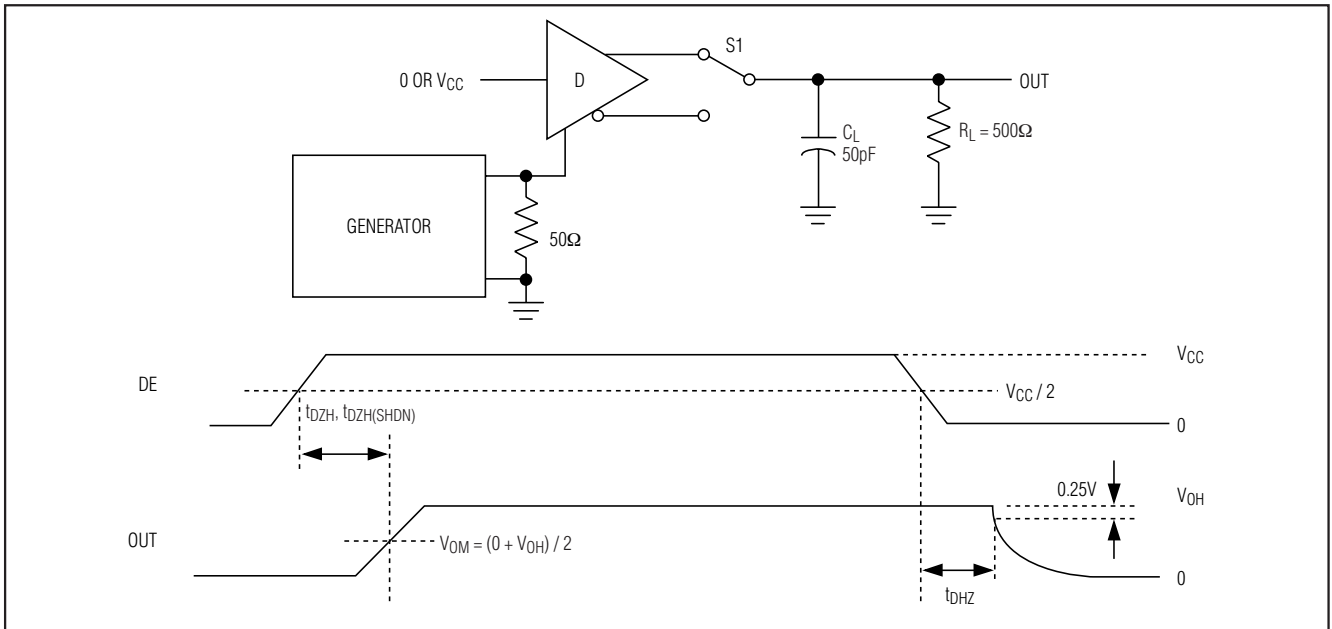
测试电路与波形(续)

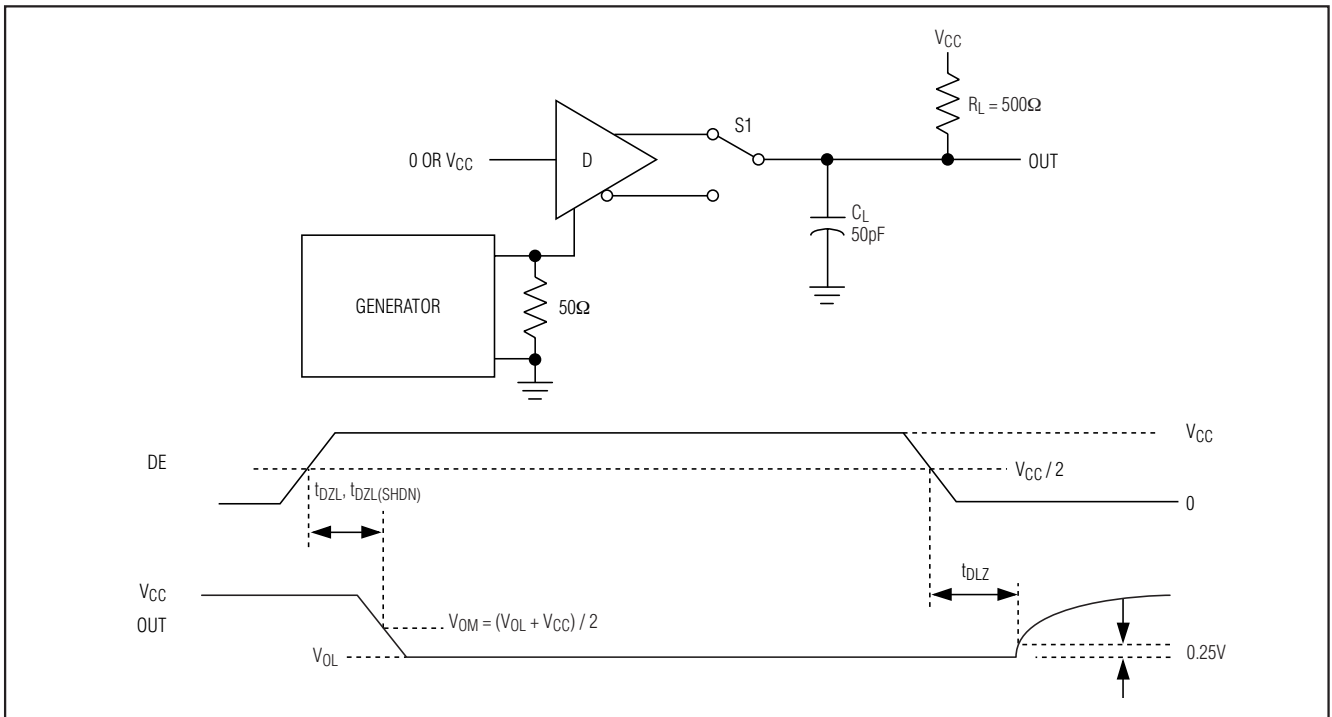

图6. 接收器传输延时测试电路



图7. 接收器传输延时

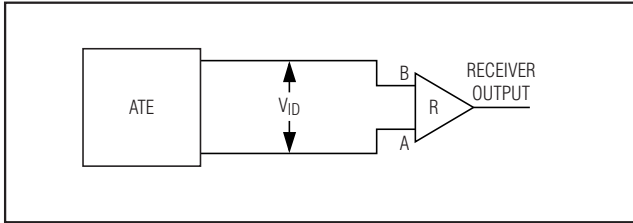

图8. 接收器使能和禁用时序

MAX13080E-MAX13089E

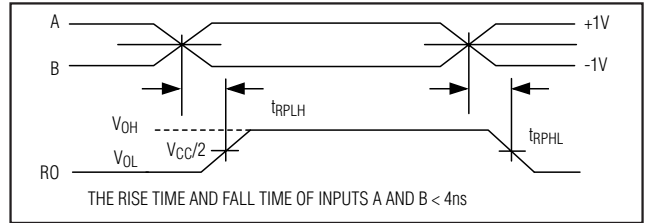
+5.0V、±15kV ESD保护、失效保护、热插拔、RS-485/RS-422收发器

MAX13080E-MAX13089E

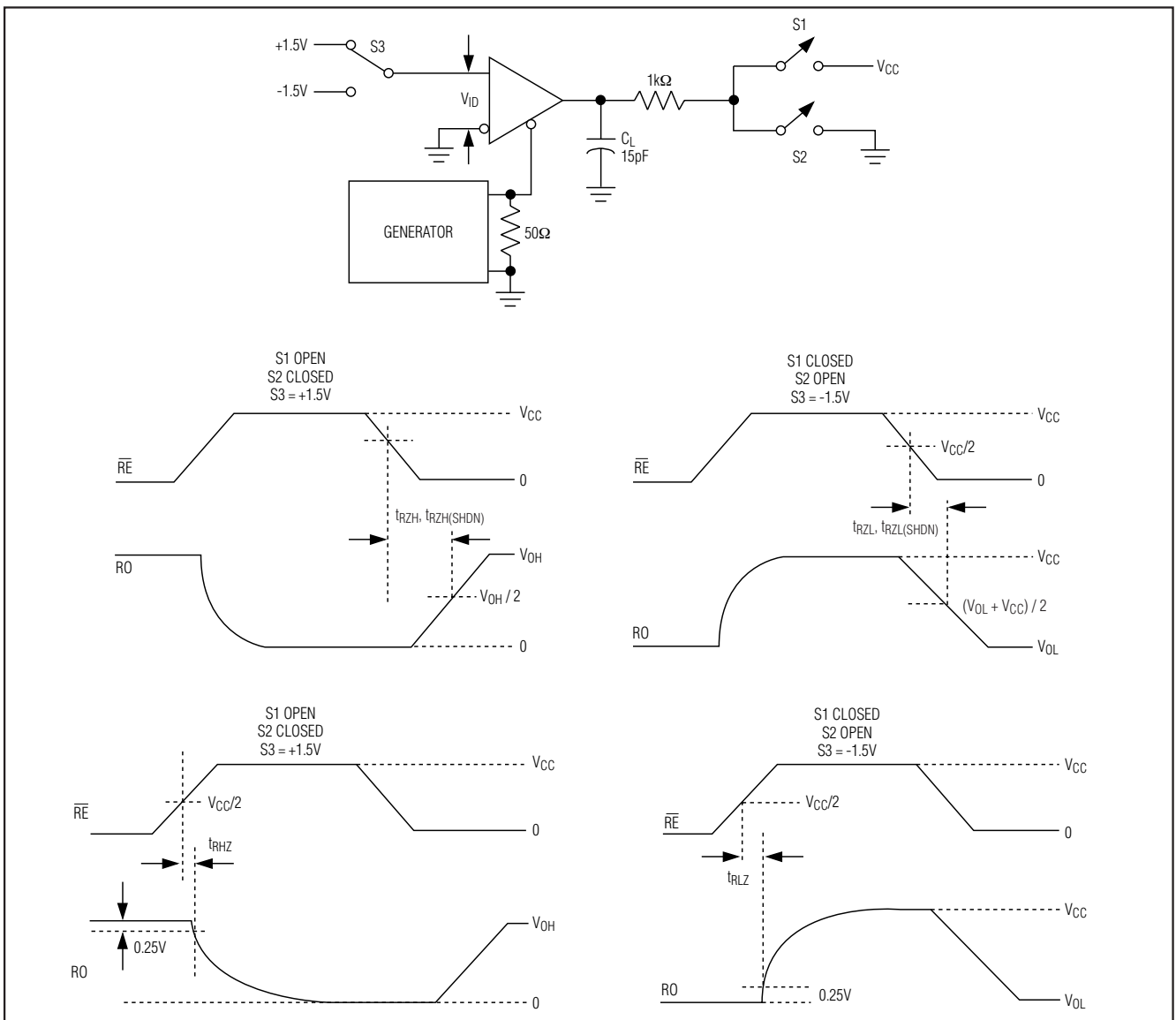
引脚说明

引脚					名称	功能
MAX13080E	MAX13081E	MAX13082E	MAX13089E			
MAX13083E	MAX13084E	MAX13085E				
MAX13086E	MAX13087E	MAX13088E				
全双工器件		半双工器件	全双工模式	半双工模式		
1, 8, 13	—	—	—	—	N.C.	无连接。内部未连接，可连接至GND。
—	—	—	1	1	H/F	半/全双工选择输入。连接H/F至V _{CC} 选择半双工模式；连接H/F至GND或悬空选择全双工模式。
2	2	1	2	2	RO	接收器输出。 \overline{RE} 为低电平时，若(A - B) ≥ -50mV，RO输出高电平；若(A - B) ≤ -200mV，RO输出低电平。
3	—	2	3	3	\overline{RE}	接收器输出使能。 \overline{RE} 接低电平时RO输出有效； \overline{RE} 接高电平时RO为高阻态。 \overline{RE} 接高电平且DE接低电平时，器件进入低功耗关断模式。 \overline{RE} 采用热插拔输入结构(详细信息请参考热插拔功能(MAX13081E/MAX13084E/MAX13087E除外)部分)。
4	—	3	4	4	DE	驱动器输出使能。DE接高电平时驱动器输出有效。DE接低电平时输出为高阻态。 \overline{RE} 接高电平且DE接低电平时，器件进入低功耗关断模式。DE采用热插拔输入结构(详细信息请参考热插拔功能(MAX13081E/MAX13084E/MAX13087E除外)部分)。
5	3	4	5	5	DI	驱动器输入。DE为高电平时，DI上的低电平强制同相输出为低电平，反相输出为高电平。同样，DI上的高电平将强制同相输出为高电平，反相输出为低电平。
—	—	—	6	6	SRL	摆率限制选择输入。将SRL接地选择16Mbps通信速率；将SRL接至V _{CC} 选择500kbps通信速率。SRL悬空时选择250kbps通信速率。
6, 7	4	5	7	7	GND	地。
—	—	—	8	8	TXP	发送器相位。将TXP接地或者悬空时，选择标准的发送器相位/极性。连接TXP至V _{CC} 时，则翻转发送器相位/极性。
9	5	—	9	—	Y	驱动器同相输出。
—	—	—	—	9	Y	驱动器同相输出和接收器同相输入。*
10	6	—	10	—	Z	驱动器反相输出。
—	—	—	—	10	Z	驱动器反相输出和接收器反相输入。*
11	7	—	11	—	B	接收器反相输入。
—	—	—	—	11	B	接收器输入电阻。*
—	—	7	—	—	B	接收器反相输入和驱动器反相输出。

+5.0V、±15kV ESD保护、失效保护、 热插拔、RS-485/RS-422收发器

引脚说明(续)

MAX13080E-MAX13089E

引脚					名称	功能
MAX13080E	MAX13081E	MAX13082E	MAX13089E			
MAX13083E	MAX13084E	MAX13085E				
MAX13086E	MAX13087E	MAX13088E				
全双工器件		半双工器件	全双工模式	半双工模式		
12	8	—	12	—	A	接收器同相输入。
—	—	—	—	12	A	接收器输入电阻。*
—	—	6	—	—	A	接收器同相输入和驱动器同相输出。
—	—	—	13	13	RXP	接收器相位。对于标准的发送器相位/极性，连接RXP至GND或者RXP保持悬空。连接RXP至V _{CC} 时，则翻转接收器相位/极性。
14	1	8	14	14	V _{CC}	正电源，V _{CC} = +5.0V ±10%。采用一个0.1μF电容旁路V _{CC} 至GND。

*仅适用于MAX13089E。在半双工模式下，驱动器输出同时作为接收器输入。全双工接收器输入(A和B)仍具有1/8单位负载(96kΩ)，虽然并未和接收器相连。

功能表

MAX13080E/MAX13083E/MAX13086E

TRANSMITTING				
INPUTS			OUTPUTS	
\overline{RE}	DE	DI	Z	Y
X	1	1	0	1
X	1	0	1	0
0	0	X	High-Z	High-Z
1	0	X	Shutdown	
RECEIVING				
INPUTS			OUTPUT	
\overline{RE}	DE	A, B	RO	
0	X	≥ -50mV	1	
0	X	≤ -200mV	0	
0	X	Open/shorted	1	
1	1	X	High-Z	
1	0	X	Shutdown	

MAX13081E/MAX13084E/MAX13086E/ MAX13087E

TRANSMITTING		
INPUT	OUTPUTS	
DI	Z	Y
1	0	1
0	1	0
RECEIVING		
INPUTS	OUTPUT	
A, B	RO	
≥ -50mV	1	
≤ -200mV	0	
Open/shorted	1	

+5.0V、±15kV ESD保护、失效保护、热插拔、RS-485/RS-422收发器

功能表(续)

MAX13082E/MAX13085E/MAX13088E

TRANSMITTING				
INPUTS			OUTPUTS	
\overline{RE}	DE	DI	B/Z	A/Y
X	1	1	0	1
X	1	0	1	0
0	0	X	High-Z	High-Z
1	0	X	Shutdown	

RECEIVING			
INPUTS			OUTPUTS
\overline{RE}	DE	A-B	RO
0	X	$\geq -50mV$	1
0	X	$\leq -200mV$	0
0	X	Open/shorted	1
1	1	X	High-Z
1	0	X	Shutdown

MAX13089E

TRANSMITTING						
INPUTS				OUTPUTS		
TXP	\overline{RE}	DE	DI	Z	Y	
0	X	1	1	0	1	
0	X	1	0	1	0	
1	X	1	1	1	0	
1	X	1	0	0	1	
X	0	0	X	High-Z	High-Z	
X	1	0	X	Shutdown		

RECEIVING						
INPUTS						OUTPUTS
H/F	RXP	\overline{RE}	DE	A, B	Y, Z	RO
0	0	0	X	$> -50mV$	X	1
0	0	0	X	$< -200mV$	X	0
0	1	0	X	$> -50mV$	X	0
0	1	0	X	$< -200mV$	X	1
1	0	0	0	X	$> -50mV$	1
1	0	0	0	X	$< -200mV$	0
1	1	0	0	X	$> -50mV$	0
1	1	0	0	X	$< -200mV$	1
0	0	0	X	Open/shorted	X	1
1	0	0	0	X	Open/shorted	1
0	1	0	X	Open/shorted	X	0
1	1	0	0	X	Open/shorted	0
X	X	1	1	X	X	High-Z
X	X	1	0	X	X	Shutdown

X = 无关; 关断模式下, 驱动器和接收器输出均为高阻态。

MAX13080E-MAX13089E

+5.0V、±15kV ESD保护、失效保护、热插拔、RS-485/RS-422收发器

MAX13080E-MAX13089E

详细说明

MAX13080E-MAX13089E系列高速RS-485/RS-422收发器包括一路驱动器和一路接收器。这些器件具有失效保护电路，当接收器输入短路或开路时，或当终端匹配传输线上的所有驱动器均处于禁用状态时，可确保接收器输出逻辑高电平(参考失效保护部分)。MAX13080E/MAX13082E/MAX13083E/MAX13085E/MAX13086E/MAX13088E/MAX13089E还具有热插拔功能，支持热插入而不会产生数据传输错误(参考热插拔功能(MAX13081E/MAX13084E/MAX13087E除外)部分)。MAX13080E/MAX13081E/MAX13082E的低摆率驱动器可降低EMI，并减小由不恰当的端接电缆引起的反射，能够实现最大250kbps的无差错数据传输；MAX13083E/MAX13084E/MAX13085E也具有摆率限制功能，能够实现最大500kbps的传输速率；MAX13086E/MAX13087E/MAX13088E的驱动器摆率不受限制，能够实现最大16Mbps的传输速率；MAX13089E的摆率可通过三态驱动器的选择引脚进行选择，以支持250kbps、500kbps和16Mbps的传输速率。

MAX13082E/MAX13085E/MAX13088E为半双工收发器；MAX13080E/MAX13081E/MAX13083E/MAX13084E/MAX13086E/MAX13087E为全双工收发器；MAX13089E可通过将选择引脚(H/F)接高电平或低电平分别选择半双工或全双工通信模式。

所有器件均采用+5.0V单电源供电。驱动器具有输出短路限流功能。热关断电路保护驱动器不会出现功耗过大。进入热关断保护后，驱动器输出被置于高阻态。

接收器输入滤波

MAX13080E-MAX13085E以及工作在250kbps或500kbps模式下的MAX13089E，其接收器除了具有输入滞回外，还包括输入滤波功能。此滤波功能提高了上升和下降缓慢的差分信号的噪声抑制能力。滤波器使接收器传输延时增加25%。

失效保护

接收器输入短路或开路时，或挂载在终端匹配传输线上的所有驱动器均处于禁用状态时，MAX13080E系列可确保接收器输出逻辑高电平。这是通过将接收器输入门限分别设置为-50mV和-200mV实现的。若差分接收器输入电

压(A - B)大于或等于-50mV，RO为逻辑高电平；若电压(A - B)小于或等于-200mV，RO为逻辑低电平。当挂载在终端匹配总线上的所有发送器都禁用时，接收器差分输入电压将通过终端电阻拉至0V。依据MAX13080E系列的接收器门限，可实现具有50mV最小噪声容限的逻辑高电平。与以往的失效保护器件不同，-50mV至-200mV门限电压符合±200mV的EIA/TIA-485标准。

热插拔功能 (MAX13081E/MAX13084E/MAX13087E除外)

热插拔输入

把电路板插入带电或正在工作的背板时，数据总线的差分干扰可能导致数据错误。电路板插入背板时，数据通信处理器启动一次上电过程。在此过程中，处理器的逻辑输出驱动器为高阻态，不能将这些器件的DE和RE输入驱动至规定的逻辑电平。处理器的逻辑驱动器在高阻态时可能会有高达±10μA的漏电流，这会引发起发器的标准CMOS使能输入漂移到不正确的逻辑电平。此外，电路板寄生电容还会将V_{CC}或者GND耦合至使能输入端。如果不具备热插拔能力，以上因素会错误地使能收发器的驱动器或接收器。

V_{CC}上升时，内部下拉电路保持DE为低电平，RE为高电平。完成初始上电过程后，下拉电路不起作用，并复位热插拔输入端。

热插拔输入电路

使能输入端具备热插拔能力。输入端有两个NMOS器件：M1和M2(图9)。当V_{CC}由零开始上升时，内部7μs定时器打开M2，设置SR锁存器，而锁存器又同时打开M1。晶体管M2可吸收1.5mA电流，M1可吸收500μA电流，通过一个5kΩ电阻将DE下拉至GND。为防止高达100pF的外部寄生电容将DE驱动至高电平，M2设计用于将DE拉至禁用状态。7μs之后，定时器关闭M2，M1继续导通，以保持DE为低电平，并防止三态漏电流将DE驱动至高电平。直到外部驱动源提供所需的输入电流后，才关闭M1。此时，SR锁存器复位，M1关闭。M1关闭时，DE恢复为标准高阻CMOS输入。只要V_{CC}降至1V以下，就会复位热插拔输入电路。

对于RE，互补电路采用两个PMOS器件将RE上拉至V_{CC}。

+5.0V、±15kV ESD保护、失效保护、热插拔、RS-485/RS-422收发器

MAX13080E-MAX13089E



图9. 驱动器使能引脚(DE)简化结构

MAX13089E 编程

MAX13089E 提供几种可编程工作模式。可编程发送器的上升和下降时间，实现最大250kbps、500kbps和16Mbps的数据速率。为选择所需的数据速率，可通过三态驱动器驱动SRL至三种可能的状态之一： V_{CC} 、GND或悬空。对于250kbps传输速率，设置三态驱动器为高阻态或使SRL悬空。对于500kbps传输速率，驱动SRL至高电平或连接至 V_{CC} 。对于16Mbps传输速率，驱动SRL至低电平或连接至GND。SRL状态可在器件工作期间进行修改，而不必中断数据通信。

双绞线有时会出现接反的情况。MAX13089E的两个引脚可以翻转驱动器和接收器的相位，从而纠正这种错误连接。正常工作情况下，驱动TXP和RXP至低电平、将它们连接至地或悬空(具有内部下拉)。驱动TXP至高电平或将其连接至 V_{CC} 来翻转驱动器相位；驱动RXP至高电平或将其连接至 V_{CC} 来翻转接收器相位。注意，当RXP为高电平时接收器门限值为正。

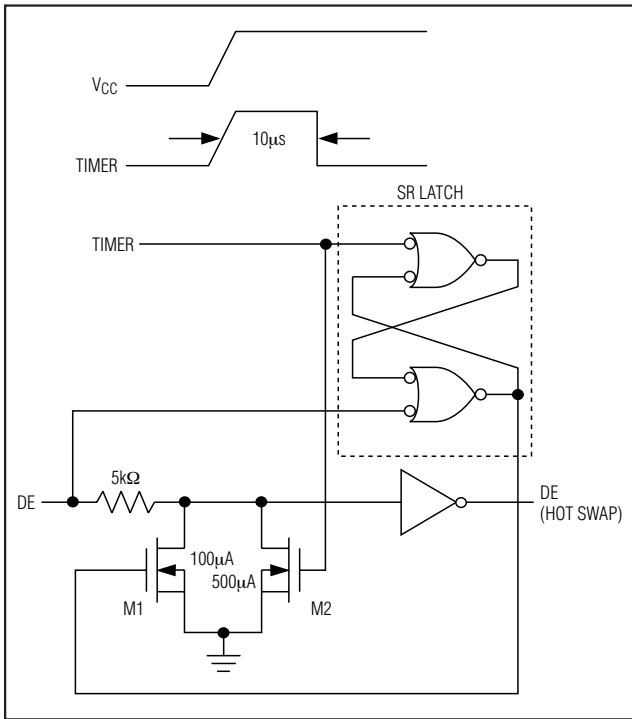
MAX13089E可工作于全双工或半双工模式。驱动H/F至低电平、保持该引脚悬空(具有内部下拉)，或者将其连接至GND可实现全双工模式。驱动H/F至高电平实现半双工

模式。在全双工模式下，驱动器和接收器的引脚配置与MAX13080E一致。在半双工模式下，接收器输入在内部通过分压电阻连接到驱动器的输出端，从而改变了驱动器输出的功能。Y成为同相驱动器输出和接收器输入，Z则成为反相驱动器输出和接收器输入。半双工模式下，A、B引脚仍通过内部分压电阻接地，但它们在内部并没有连接到接收器。

±15kV ESD保护

类似于Maxim的其它相关器件，所有引脚都采用了ESD保护结构，在操作与装配过程中出现静电放电时可对器件提供保护。MAX13080E系列产品的驱动器输出与接收器输入具有额外的静电保护能力。Maxim的工程师们已开发出目前技术水平最高的电路结构，为这些引脚提供保护，使其能够承受±15kV的ESD冲击。ESD保护结构在所有状态下都可承受高ESD冲击，包括标准工作模式、关断和断电模式。受到ESD冲击后，MAX13080E-MAX13089E能够继续工作而不会闭锁或损坏。

ESD保护可以采用不同方法进行测试。MAX13080E-MAX13089E的发送器输出与接收器输入在以下条件下进行了保护测试：

- ±15kV，人体模型。
- ±6kV，IEC 61000-4-2规定的接触放电方法。

ESD测试条件

ESD性能取决于多种条件。若需包括测试条件、方法和结果在内的可靠性报告，请与Maxim联系。

人体模型

图10a所示为人体模型，对低阻放电时产生的电流波形如图10b所示。该模型包括一个100pF电容，先充电至所需的ESD电压，然后通过1.5kΩ电阻向被测器件放电。

IEC 61000-4-2

IEC 61000-4-2标准涵盖了成品设备的ESD测试与性能，但它并不是专门针对集成电路。MAX13080E系列器件帮助用户设计符合IEC 61000-4-2要求的设备，而不需要额外的ESD保护元件。

使用人体模型与IEC 61000-4-2进行测试的主要区别在于IEC 61000-4-2测试的峰值电流更高，这是由于IEC 61000-4-2模型具有更小的串联电阻。因此，IEC 61000-4-2测试的ESD耐受电压通常低于使用人体模型测试的结果。图10c所示为IEC 61000-4-2模型，图10d所示为IEC 61000-4-2 ESD接触放电测试的电流波形。

+5.0V、±15kV ESD保护、失效保护、热插拔、RS-485/RS-422收发器

MAX13080E-MAX13089E



图10a. 人体ESD测试模型



图10c. IEC 61000-4-2 ESD测试模型

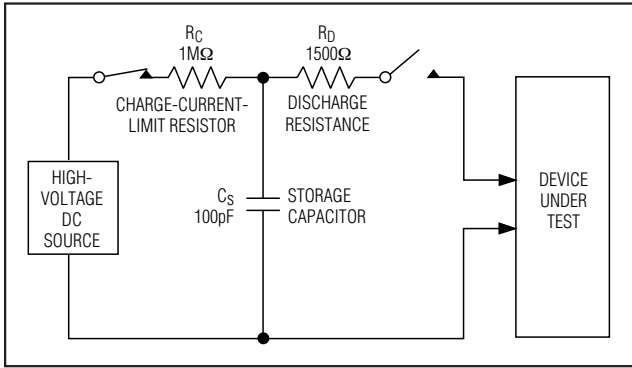

图10b. 人体电流波形

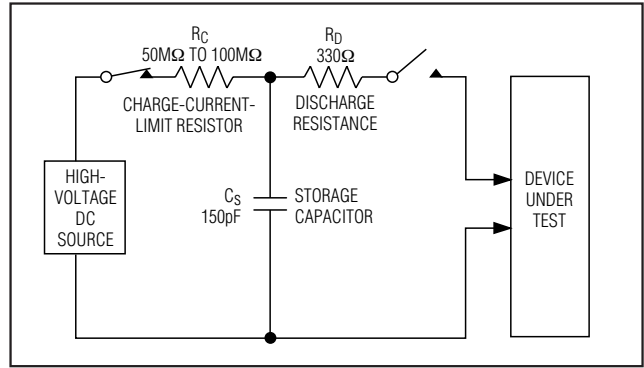

图10d. IEC 61000-4-2 ESD产生的电流波形

机器模型

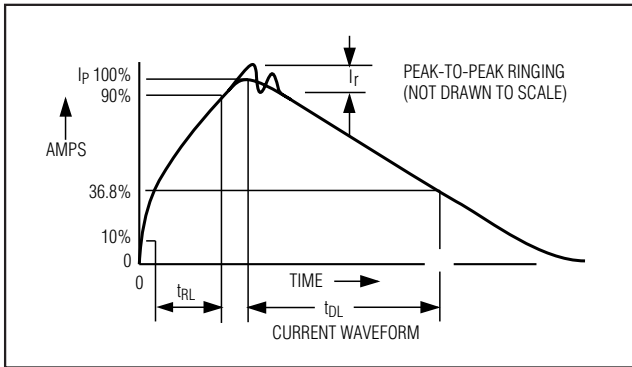
机器模型ESD测试采用200pF存储电容和零放电电阻对所有引脚进行测试。其目的是模拟测试和装配过程中操作设备接触I/O引脚所产生的静电冲击。当然所有引脚都需要这种保护，而不只是RS-485输入与输出引脚。

可任意组合，或者与其它RS-485收发器进行组合，只要总负载不超过32个单位负载，都可以挂接在同一总线上。

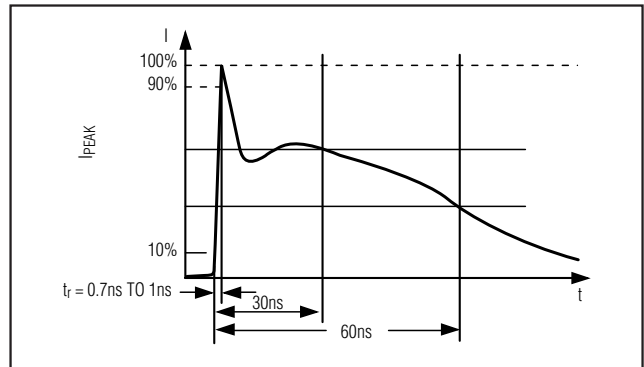
降低EMI和反射

MAX13080E/MAX13081E/MAX13082E的低摆率驱动器可以减小EMI，并降低由不恰当的终端匹配电缆引起的反射，可实现最大250kbps的无差错数据传输。MAX13083E/MAX13084E/MAX13085E提供较高的驱动器输出摆率，可实现高达500kbps的传输速率。MAX13089E在SRL = VCC或者SRL悬空时具有摆率控制功能。SRL悬空时，MAX13089E可实现高达250kbps的无差错数据传输。SRL连接至VCC时，数据传输速率可高达500kbps。

应用信息

总线上挂接256个收发器

标准RS-485接收器的输入阻抗为12kΩ（1个单位负载），标准驱动器可最多驱动32个单位负载。MAX13080E系列收发器的接收器具有1/8单位负载输入阻抗（96kΩ），允许最多256个收发器并行挂接在同一通信总线上。这些器件

+5.0V、±15kV ESD保护、失效保护、热插拔、RS-485/RS-422收发器

MAX13080E-MAX13089E

低功耗关断模式

(MAX13081E/MAX13084E/MAX13087E除外)

\overline{RE} 接高电平且DE接低电平时，启动低功耗关断模式。关断模式下，器件仅吸收典型值为2.8 μ A的电源电流。

可以同时驱动 \overline{RE} 和DE，如果 \overline{RE} 为高电平且DE为低电平的持续时间小于50ns，可以确保器件不会进入关断模式。如果输入端维持这种状态700ns以上，则可确保这些器件进入关断模式。

使能时间 t_{ZH} 与 t_{ZL} (见 *Switching Characteristics* 部分)假定器件并未处于低功耗关断状态。使能时间 $t_{ZH}(SHDN)$ 与 $t_{ZL}(SHDN)$ 假定器件处于关断状态。从低功耗关断模式到驱动器和接收器转变为有效状态所需要的时间($t_{ZH}(SHDN)$ 、 $t_{ZL}(SHDN)$)，要比从禁用模式下转变为有效状态所需要的时间(t_{ZH} 、 t_{ZL})长。



图11. MAX13080E/MAX13081E/MAX13083E/MAX13084E/MAX13086E/MAX13087E/MAX13089E全双工模式下的线路中继器

驱动器输出保护

通过两种机制避免故障或总线冲突引起输出电流过大和功耗过高。第一，输出级折返式限流，在整个共模电压范围(参考典型工作特性)内提供快速短路保护。第二，热关断电路，当管芯温度超过+175°C (典型值)时，强制驱动器输出进入高阻状态。

传输线长度

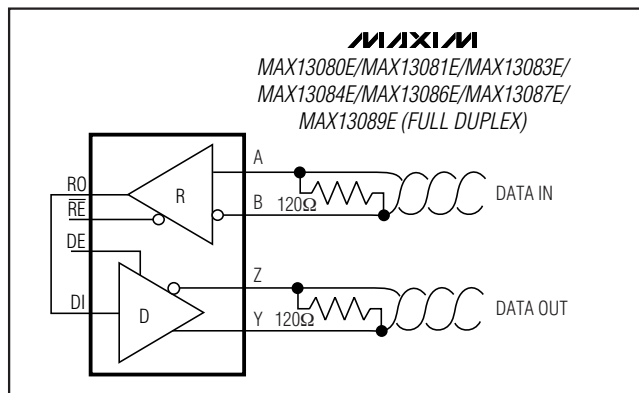
RS-485/RS-422标准适用于最大4000英尺的线路长度。对大于4000英尺的线路长度，可采用图11所示的线路中继器。

典型应用

MAX13082E/MAX13085E/MAX13088E/MAX13089E收发器设计用于多点总线传输线上的双向数据通信。图12与图13给出了典型网络应用电路。

为减小反射，应当在传输线两端以其特性阻抗进行终端匹配，主干线以外的分支连线长度应尽可能短。具有摆率限制的MAX13082E/MAX13085E以及工作在两种限摆率模式下的MAX13089E能够允许不良终端匹配。

芯片信息

TRANSISTOR COUNT: 1228
PROCESS: BiCMOS



图12. 典型半双工RS-485网络

+5.0V、±15kV ESD保护、失效保护、热插拔、RS-485/RS-422收发器

MAX13080E-MAX13089E

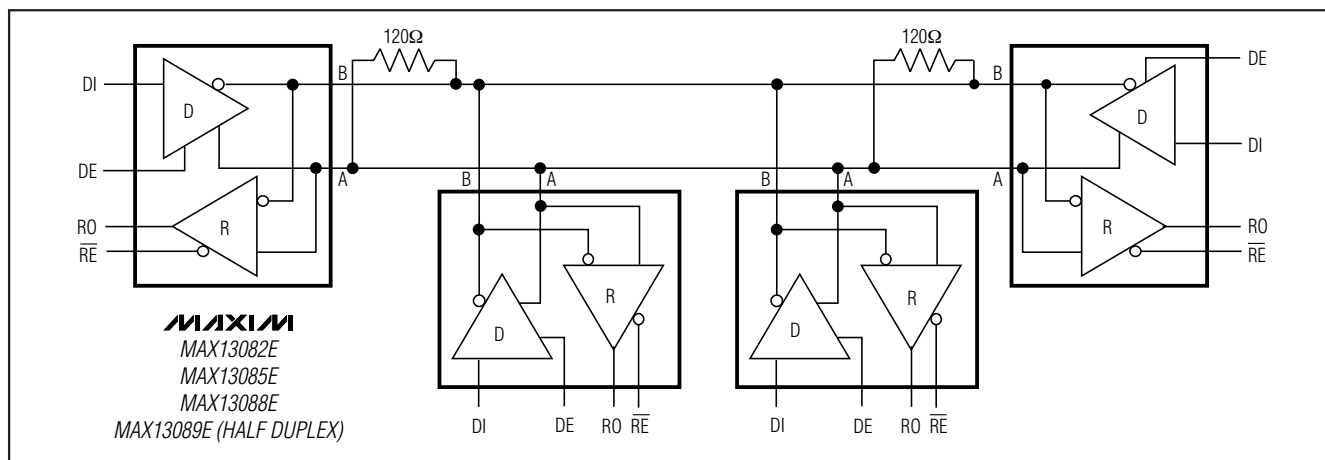

图13. 典型全双工RS-485网络

选型指南

PART	HALF/FULL DUPLEX	DATA RATE (Mbps)	SLEW-RATE LIMITED	LOW-POWER SHUTDOWN	RECEIVER/ DRIVER ENABLE	TRANSCEIVERS ON BUS	PINS
MAX13080E	Full	0.250	Yes	Yes	Yes	256	14
MAX13081E	Full	0.250	Yes	No	No	256	8
MAX13082E	Half	0.250	Yes	Yes	Yes	256	8
MAX13083E	Full	0.5	Yes	Yes	Yes	256	14
MAX13084E	Full	0.5	Yes	No	No	256	8
MAX13085E	Half	0.5	Yes	Yes	Yes	256	8
MAX13086E	Full	16	No	Yes	Yes	256	14
MAX13087E	Full	16	No	No	No	256	8
MAX13088E	Half	16	No	Yes	Yes	256	8
MAX13089E	Selectable	Selectable	Selectable	Yes	Yes	256	14

+5.0V、±15kV ESD保护、失效保护、热插拔、RS-485/RS-422收发器

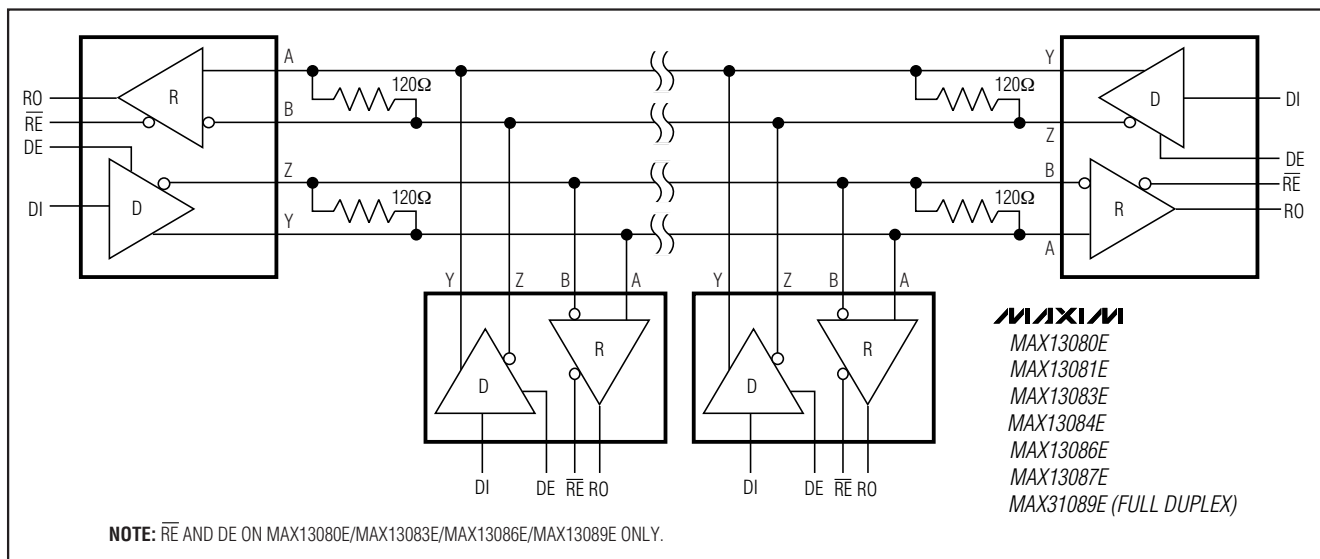
MAX13080E-MAX13089E

引脚配置和典型工作电路

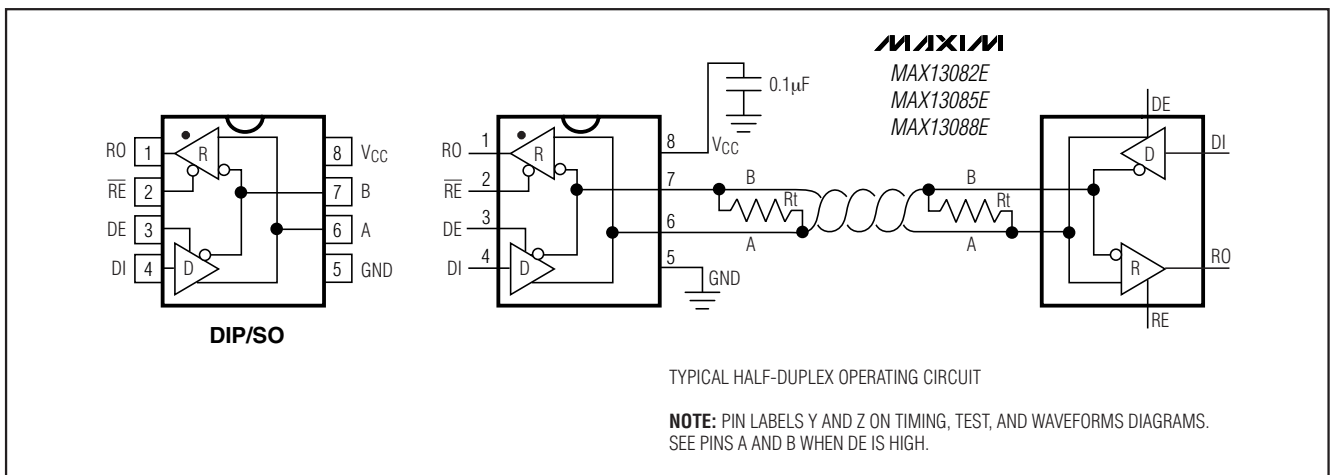
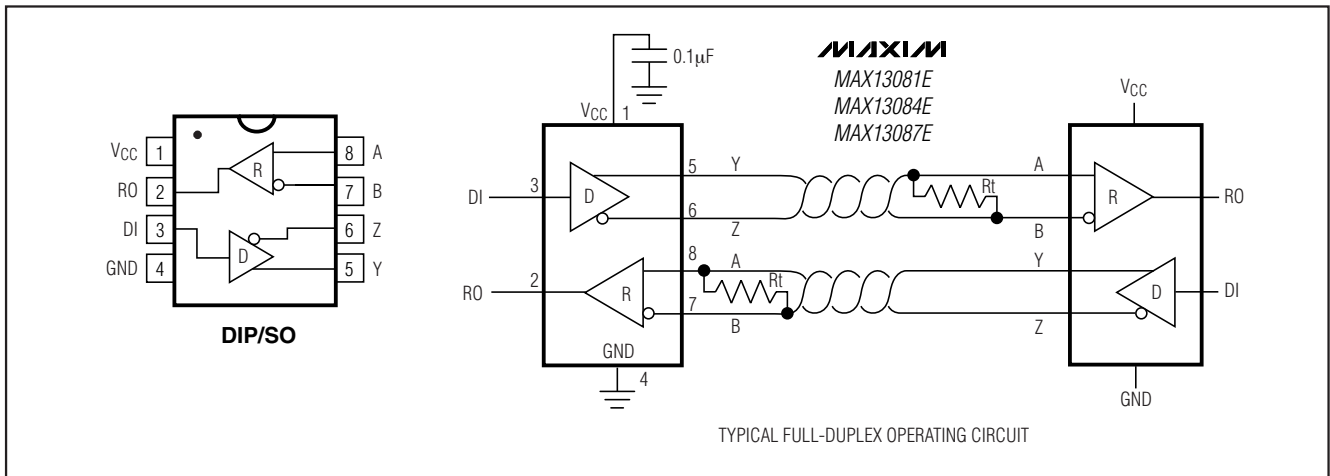
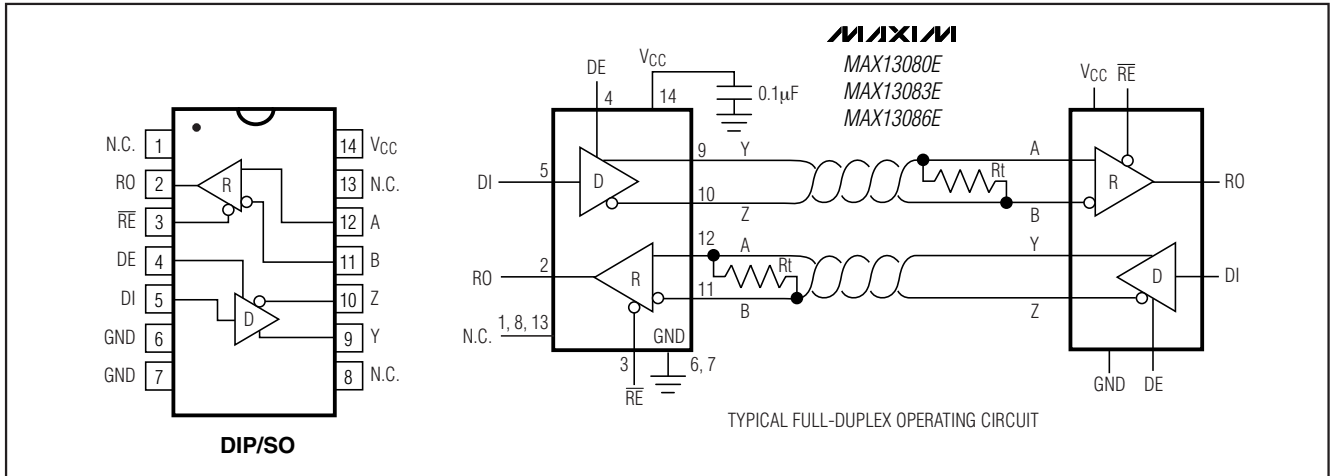

+5.0V、±15kV ESD保护、失效保护、热插拔、RS-485/RS-422收发器

引脚配置和典型工作电路(续)

MAX13080E-MAX13089E

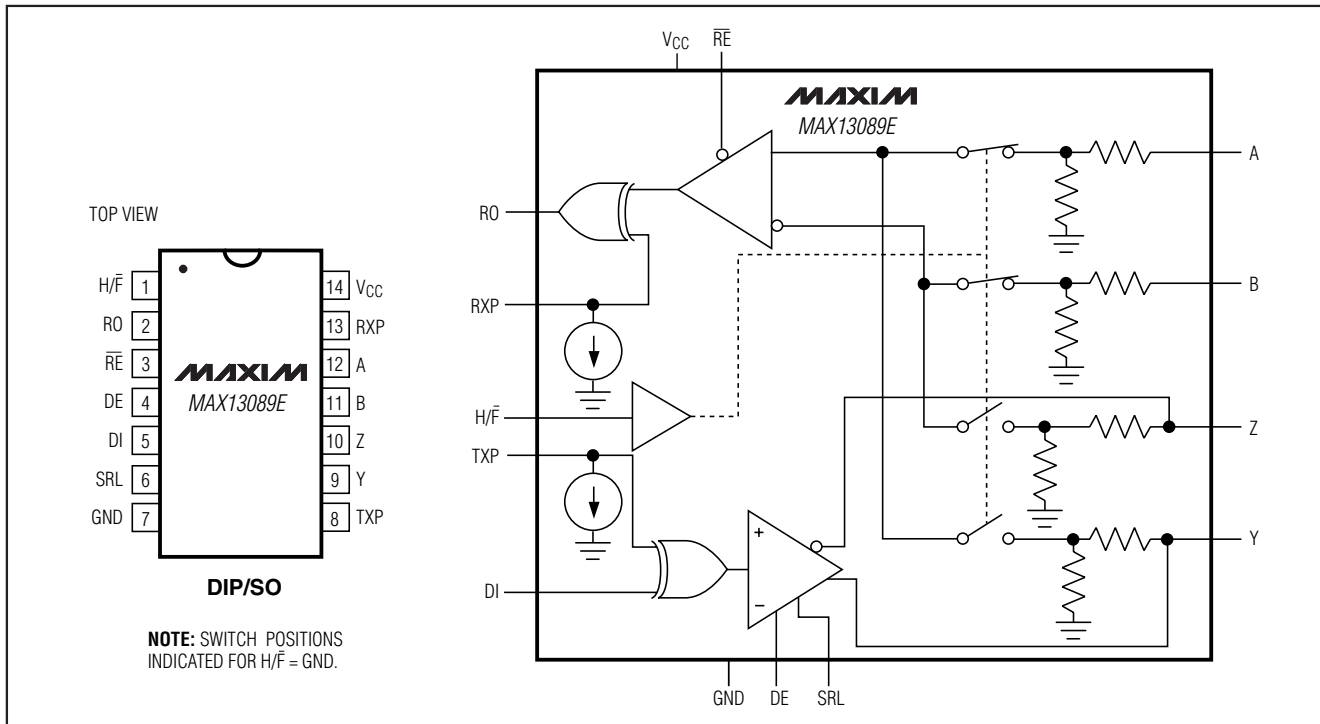

+5.0V、±15kV ESD保护、失效保护、热插拔、RS-485/RS-422收发器

MAX13080E-MAX13089E

订购信息(续)

PART	TEMP RANGE	PIN-PACKAGE	PKG CODE
MAX13081 ECPA	0°C to +70°C	8 PDIP	P8-2
MAX13081>ECSA	0°C to +70°C	8 SO	S8-4
MAX13081>EEPA	-40°C to +85°C	8 PDIP	P8-2
MAX13081>EESA	-40°C to +85°C	8 SO	S8-4
MAX13081>EAPA	-40°C to +125°C	8 PDIP	P8-2
MAX13081>EASA	-40°C to +125°C	8 SO	S8-4
MAX13082 ECPA	0°C to +70°C	8 PDIP	P8-2
MAX13082>ECSA	0°C to +70°C	8 SO	S8-4
MAX13082>EEPA	-40°C to +85°C	8 PDIP	P8-2
MAX13082>EESA	-40°C to +85°C	8 SO	S8-4
MAX13082>EAPA	-40°C to +125°C	8 PDIP	P8-2
MAX13082>EASA	-40°C to +125°C	8 SO	S8-4
MAX13083 ECPD	0°C to +70°C	14 PDIP	P14-3
MAX13083>ECSD	0°C to +70°C	14 SO	S14-2
MAX13083>EEPD	-40°C to +85°C	14 PDIP	P14-3
MAX13083>EESD	-40°C to +85°C	14 SO	S14-2
MAX13083>EAPD	-40°C to +125°C	14 PDIP	P14-3
MAX13083>EASD	-40°C to +125°C	14 SO	S14-2
MAX13084 ECPA	0°C to +70°C	8 PDIP	P8-2
MAX13084>ECSA	0°C to +70°C	8 SO	S8-4
MAX13084>EEPA	-40°C to +85°C	8 PDIP	P8-2
MAX13084>EESA	-40°C to +85°C	8 SO	S8-4
MAX13084>EAPA	-40°C to +125°C	8 PDIP	P8-2
MAX13084>EASA	-40°C to +125°C	8 SO	S8-4
MAX13085 ECPA	0°C to +70°C	8 PDIP	P8-2
MAX13085>ECSA	0°C to +70°C	8 SO	S8-4
MAX13085>EEPA	-40°C to +85°C	8 PDIP	P8-2
MAX13085>EESA	-40°C to +85°C	8 SO	S8-4
MAX13085>EAPA	-40°C to +125°C	8 PDIP	P8-2
MAX13085>EASA	-40°C to +125°C	8 SO	S8-4

PART	TEMP RANGE	PIN-PACKAGE	PKG CODE
MAX13086 ECPD	0°C to +70°C	14 PDIP	P14-3
MAX13086>ECSD	0°C to +70°C	14 SO	S14-2
MAX13086>EEPD	-40°C to +85°C	14 PDIP	P14-3
MAX13086>EESD	-40°C to +85°C	14 SO	S14-2
MAX13086>EAPD	-40°C to +125°C	14 PDIP	P14-3
MAX13086>EASD	-40°C to +125°C	14 SO	S14-2
MAX13087 ECPA	0°C to +70°C	8 PDIP	P8-2
MAX13087>ECSA	0°C to +70°C	8 SO	S8-4
MAX13087>EEPA	-40°C to +85°C	8 PDIP	P8-2
MAX13087>EESA	-40°C to +85°C	8 SO	S8-4
MAX13087>EAPA	-40°C to +125°C	8 PDIP	P8-2
MAX13087>EASA	-40°C to +125°C	8 SO	S8-4
MAX13088 ECPA	0°C to +70°C	8 PDIP	P8-2
MAX13088>ECSA	0°C to +70°C	8 SO	S8-4
MAX13088>EEPA	-40°C to +85°C	8 PDIP	P8-2
MAX13088>EESA	-40°C to +85°C	8 SO	S8-4
MAX13088>EAPA	-40°C to +125°C	8 PDIP	P8-2
MAX13088>EASA	-40°C to +125°C	8 SO	S8-4
MAX13089 ECPD	0°C to +70°C	14 PDIP	P14-3
MAX13089>ECSD	0°C to +70°C	14 SO	S14-2
MAX13089>EEPD	-40°C to +85°C	14 PDIP	P14-3
MAX13089>EESD	-40°C to +85°C	14 SO	S14-2
MAX13089>EAPD	-40°C to +125°C	14 PDIP	P14-3
MAX13089>EASD	-40°C to +125°C	14 SO	S14-2

+5.0V、±15kV ESD保护、失效保护、 热插拔、RS-485/RS-422收发器

封装信息

(本数据资料提供的封装图可能不是最近的规格，如需最近的封装外型信息，请查询 www.maxim-ic.com.cn/packages.)

MAX13080E-MAX13089E

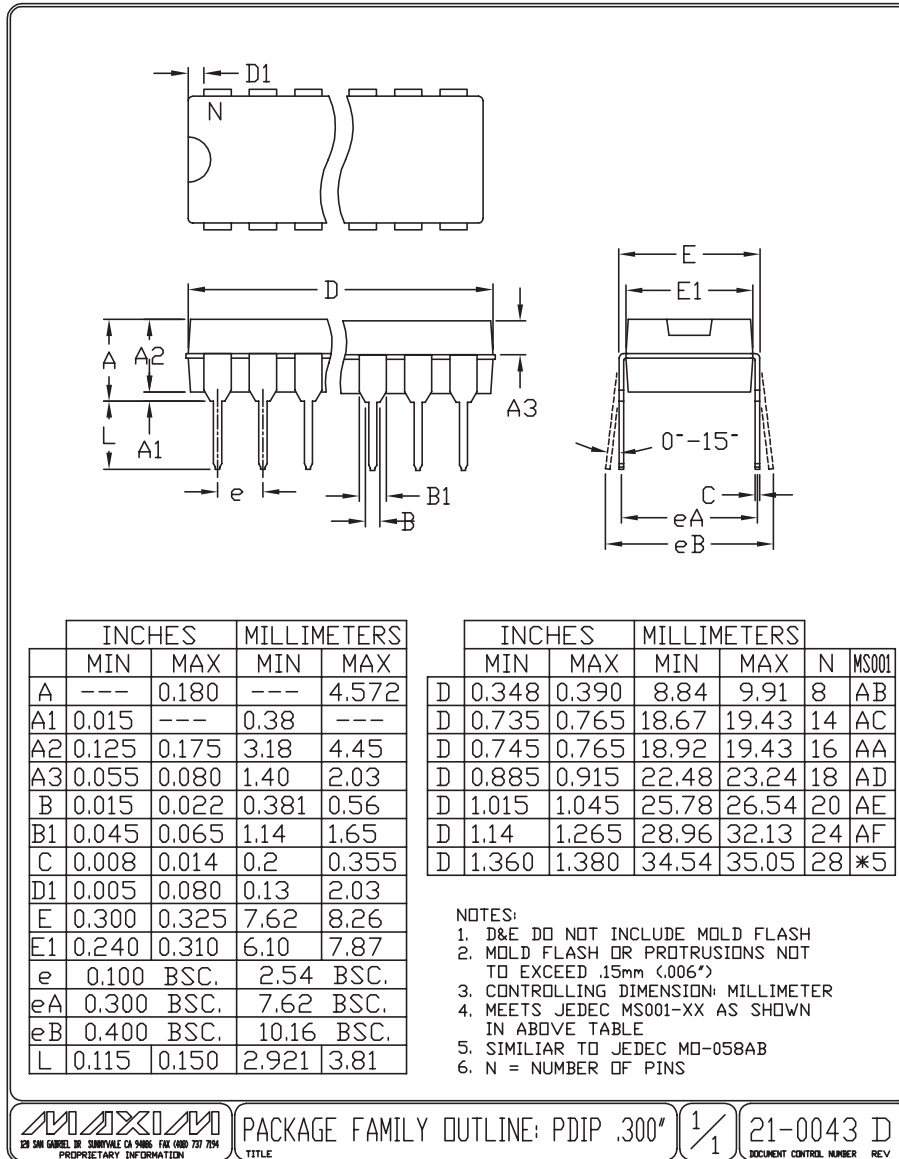

+5.0V、±15kV ESD保护、失效保护、热插拔、RS-485/RS-422收发器

MAX13080E-MAX13089E

封装信息(续)

(本数据资料提供的封装图可能不是最近的规格, 如需最近的封装外型信息, 请查询 www.maxim-ic.com.cn/packages.)

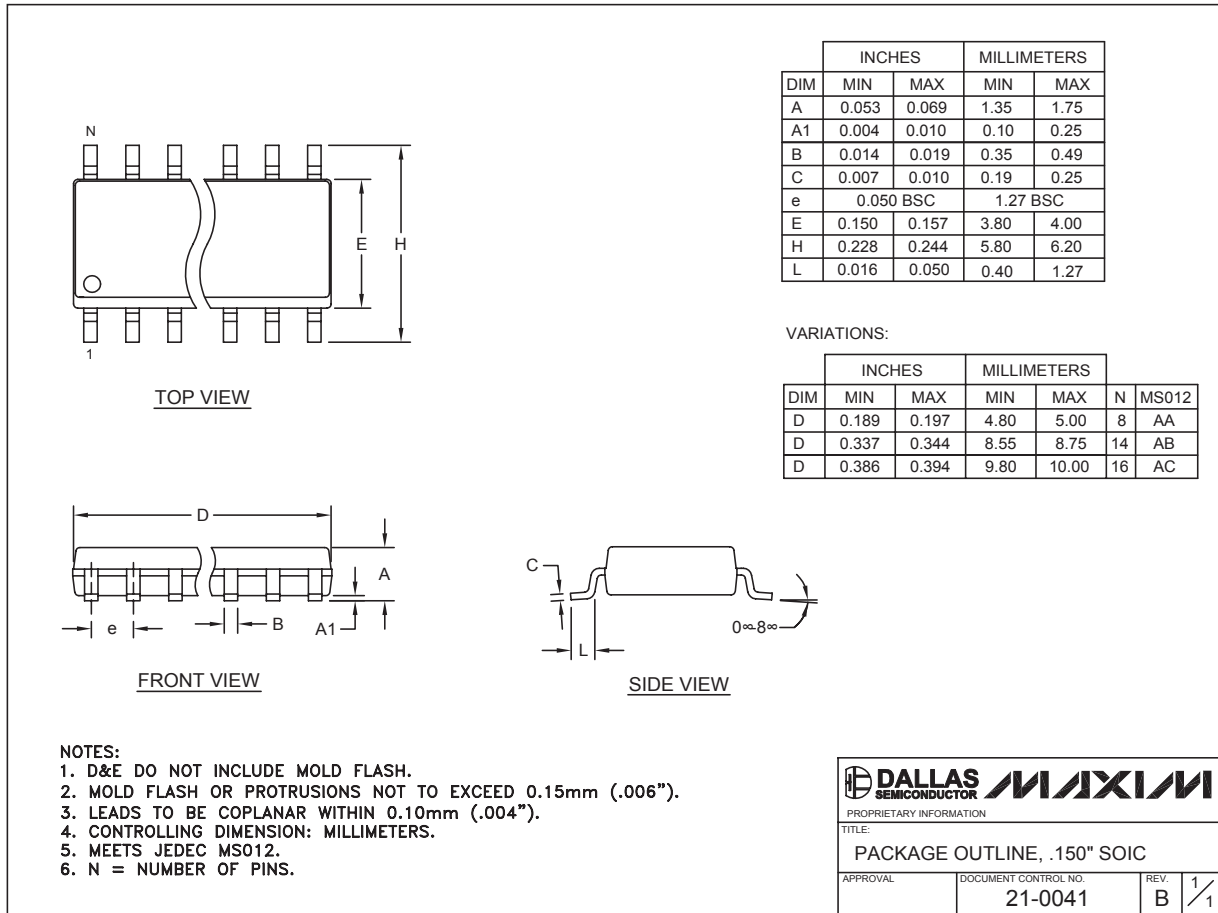

MAXIM北京办事处

北京 8328 信箱 邮政编码 100083
 免费电话: 800 810 0310
 电话: 010-6211 5199
 传真: 010-6211 5299

Maxim 不对 Maxim 产品以外的任何电路使用负责, 也不提供其专利许可。Maxim 保留在任何时间、没有任何通报的前提下修改产品资料和规格的权利。

24 Maxim Integrated Products, 120 San Gabriel Drive, Sunnyvale, CA 94086 (408) 737-7600

© 2005 Maxim Integrated Products

Printed USA

MAXIM 是 Maxim Integrated Products, Inc. 的注册商标。

项目开发 芯片解密 零件配单 TEL: 15013652265 QQ: 38537442