

SOT23封装、USB/AC适配器双输入、
单节Li+电池充电器

概述

MAX1551/MAX1555可以从USB*或AC适配器电源为单节Li+电池提供充电。它们无需外部场效应管或二极管即可工作，并可工作在高达7V的输入电压。

片上温度限制电路简化了PC板的布局，并允许优化充电速率，使其在电池状况最差、输入电压最高的情况下不会达到温度限制值；而当MAX1551/MAX1555达到温度限制的阈值时，充电器不会关断，而是逐步减小充电电流。

MAX1551包含一个 $\overline{\text{POK}}$ 输出，用于指示是否连接了输入电源。任何一路充电电源有效， $\overline{\text{POK}}$ 会置为低电平。MAX1555则利用 $\overline{\text{CHG}}$ 输出指示充电状态。

当与USB连接，但没有DC电源时，充电电流被置为100mA（最大值）。这样，加电或未加电的USB集线器均可用于充电，无需端口通信。当连接了DC电源时，充电电流被置为280mA（典型值）。无须使用输入屏蔽二极管来防止电池漏电。

MAX1551/MAX1555采用5引脚、薄型SOT23封装，工作在-40°C至+85°C温度范围内。

应用

PDA

无线设备
蜂窝电话
数码相机

特性

- ◆ 使用USB或AC适配器进行充电
- ◆ 插入AC适配器时可自动进行切换
- ◆ 片上温度限制电路简化电路板设计
- ◆ 充电状态指示
- ◆ 5引脚、薄型SOT23封装
- ◆ 受美国专利#6,507,172保护

订购信息

PART	TEMP RANGE	PIN-PACKAGE
MAX1551EZK-T	-40°C to +85°C	5 Thin SOT23-5
MAX1555EZK-T	-40°C to +85°C	5 Thin SOT23-5

选择指南

PART	TOP MARK	FEATURES
MAX1551EZK	ADRT	$\overline{\text{POK}}$ Output
MAX1555EZK	ADRU	$\overline{\text{CHG}}$ Output

引脚配置

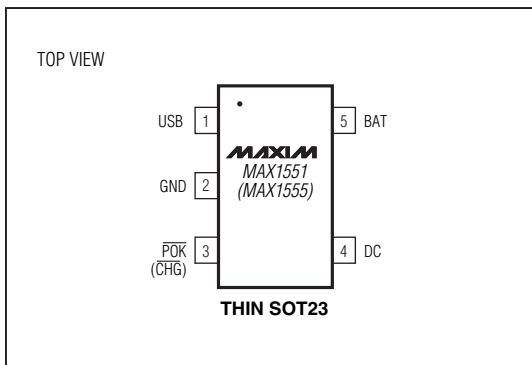

*Protected by U.S. Patent #6,507,172.

典型工作电路

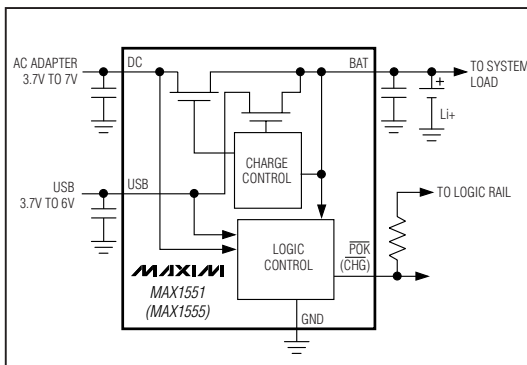

SOT23封装、USB/AC适配器双输入、 单节Li+电池充电器

MAX1551/MAX1555

ABSOLUTE MAXIMUM RATINGS

DC to GND	0 to +8V	Operating Temperature Range	-40°C to +85°C
DC to BAT	0 to +7V	Junction Temperature Range	-40°C to +150°C
BAT, CHG, POK, USB to GND	-0.3V to +7V	Storage Temperature Range	-65°C to +150°C
Continuous Power Dissipation (T _A = +70°C)		Lead Temperature (soldering, 10s)	+300°C
5-Pin Thin SOT23 (derate 9.1mW/°C above +70°C)	727mW		

Stresses beyond those listed under "Absolute Maximum Ratings" may cause permanent damage to the device. These are stress ratings only, and functional operation of the device at these or any other conditions beyond those indicated in the operational sections of the specifications is not implied. Exposure to absolute maximum rating conditions for extended periods may affect device reliability.

ELECTRICAL CHARACTERISTICS

(V_{DC} = 5V, V_{USB} = 0, I_{BAT} = 0, C_{BAT} = 1μF, T_A = 0°C to +85°C, unless otherwise noted.)

PARAMETER	CONDITIONS	MIN	TYP	MAX	UNITS
DC					
DC Voltage Range	(Note 1)	3.7		7.0	V
DC to BAT Voltage Range		0.1		6.0	V
DC Undervoltage Lockout Threshold	Input rising, 430mV hysteresis, V _{BAT} = 3V (Note 1)	3.75	3.95	4.15	V
DC Supply Current			1.75	3	mA
DC to BAT On-Resistance	V _{DC} = 3.7V, V _{BAT} = 3.6V		1	2	Ω
DC to BAT Dropout Voltage	When charging stops, V _{BAT} = 4V, DC falling, 200mV hysteresis	30	60	90	mV
USB					
USB Voltage Range	(Note 1)	3.7		6.0	V
USB Undervoltage Threshold	Input rising, 430mV hysteresis, V _{DC} = 0, V _{BAT} = 3V (Note 1)	3.75	3.95	4.15	V
USB Supply Current	V _{USB} = 5V, V _{DC} = 0		1.65	3	mA
USB to BAT On-Resistance	V _{USB} = 3.7V, V _{BAT} = 3.6V, V _{DC} = 0		2	4	Ω
USB to BAT Dropout Voltage	When charging stops, V _{BAT} = 4V, USB falling, 200mV hysteresis, V _{DC} = 0	30	60	90	mV
BAT					
BAT Regulation Voltage	V _{DC} or V _{USB} = 5V	4.158	4.2	4.242	V
DC Charging Current	V _{BAT} = 3.3V, V _{USB} = 0, V _{DC} = 5V	220	280	340	mA
USB Charging Current	V _{BAT} = 3.3V, V _{DC} = 0, V _{USB} = 5V	80	90	100	mA
BAT Prequal Threshold	V _{BAT} rising, 100mV hysteresis	2.9	3	3.1	V
Prequalification Charging Current	V _{BAT} = 2.8V	20	40	80	mA
BAT Leakage Current	V _{DC} = V _{USB} = 0, V _{BAT} = 4.2V			5	μA
POK, CHG, AND THERMAL LIMIT					
CHG Threshold	Charge current where CHG goes high, I _{BAT} falling, 50mA hysteresis	25	50	100	mA
CHG, POK Logic-Low Output	I _{CHG} , I _{POK} = 10mA		150	300	mV
CHG, POK Leakage Current	V _{CHG} , V _{POK} = 6V, T _A = +25°C		0.001	1	μA
Thermal-Limit Temperature	Charge current reduced by 17mA/°C above this temperature		+110		°C

SOT23封装、USB/AC适配器双输入、
单节Li+电池充电器

MAX1551/MAX1555

ELECTRICAL CHARACTERISTICS

($V_{DC} = 5V$, $V_{USB} = 0$, $I_{BAT} = 0$, $C_{BAT} = 1\mu F$, $T_A = -40^{\circ}C$ to $+85^{\circ}C$, unless otherwise noted.) (Note 2)

PARAMETER	CONDITIONS	MIN	MAX	UNITS
DC				
DC Voltage Range	(Note 1)	3.7	7.0	V
DC to BAT Voltage Range		0.1	6.0	V
DC Undervoltage Lockout Threshold	Input rising, 430mV hysteresis, $V_{BAT} = 3V$ (Note 1)	3.75	4.15	V
DC Supply Current			3	mA
DC to BAT On-Resistance	$V_{DC} = 3.7V$, $V_{BAT} = 3.6V$		2	Ω
DC to BAT Dropout Voltage	When charging stops, $V_{BAT} = 4V$, DC falling, 200mV hysteresis	30	95	mV
USB				
USB Voltage Range	(Note 1)	3.7	6.0	V
USB Undervoltage Lockout Threshold	Input rising, 430mV hysteresis, $V_{DC} = 0$, $V_{BAT} = 3V$ (Note 1)	3.75	4.15	V
USB Supply Current	$V_{USB} = 5V$, $V_{DC} = 0$		3	mA
USB to BAT On-Resistance	$V_{USB} = 3.7V$, $V_{BAT} = 3.6V$, $V_{DC} = 0$		4	Ω
USB to BAT Dropout Voltage	When charging stops, $V_{BAT} = 4V$, USB falling, 200mV hysteresis, $V_{DC} = 0$	30	95	mV
BAT				
BAT Regulation Voltage	V_{DC} or $V_{USB} = 5V$	4.141	4.259	V
DC Charging Current	$V_{BAT} = 3.3V$, $V_{USB} = 0$, $V_{DC} = 5V$	220	340	mA
USB Charging Current	$V_{BAT} = 3.3V$, $V_{DC} = 0$, $V_{USB} = 5V$	80	100	mA
BAT Prequal Threshold	V_{BAT} rising, 100mV hysteresis	2.9	3.1	V
Prequalification Charging Current	$V_{BAT} = 2.8V$	20	80	mA
BAT Leakage Current	$V_{DC} = V_{USB} = 0$, $V_{BAT} = 4.2V$		5	μA
POK, CHG				
\overline{CHG} Threshold	Charge current where \overline{CHG} goes high, I_{BAT} falling, 50mA hysteresis	25	100	mA
\overline{CHG} , POK Logic-Low Output	$I_{\overline{CHG}}$, $I_{POK} = 10mA$		300	mV
\overline{CHG} , POK Leakage Current	$V_{\overline{CHG}}$, $V_{POK} = 6V$, $T_A = +25^{\circ}C$		1	μA

Note 1: The input undervoltage lockout has 430mV of hysteresis. The charger turns on when an input rises to 3.95V (typ), and turns off when it falls below 3.52V.

Note 2: Specifications to $-40^{\circ}C$ are guaranteed by design, not production tested.

SOT23封装、USB/AC适配器双输入、单节Li+电池充电器

典型工作特性

($V_{DC} = 5V$, $V_{USB} = 0$, $I_{BAT} = 0$, $C_{BAT} = 1\mu F$, $T_A = +25^\circ C$, unless otherwise noted.)

MAX1551/MAX1555

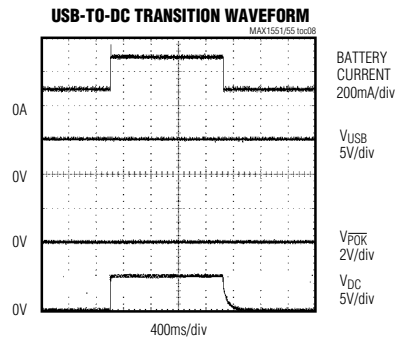
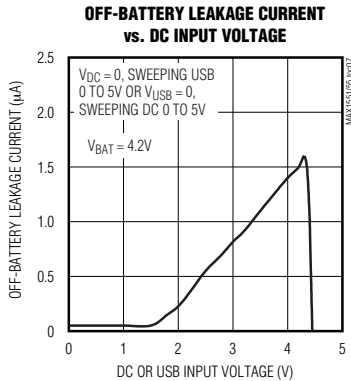
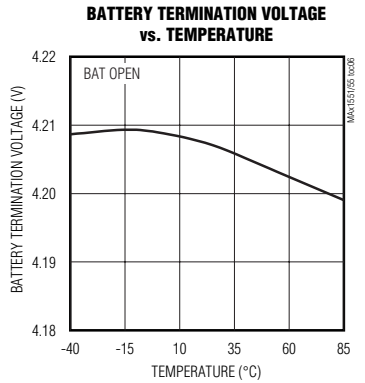
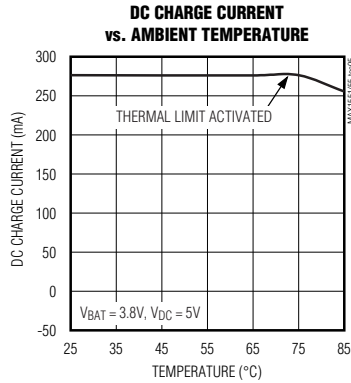
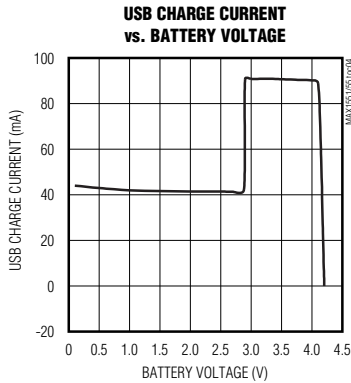
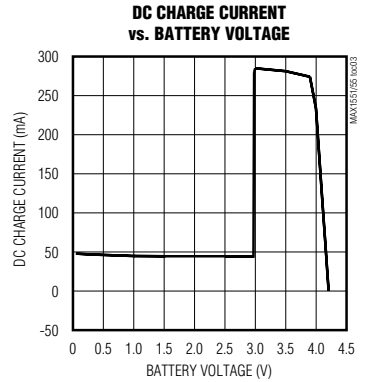
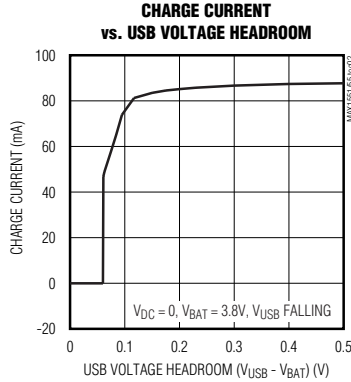
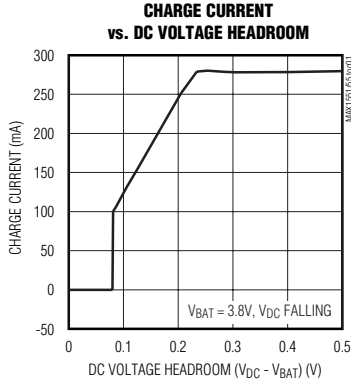

SOT23封装、USB/AC适配器双输入、单节Li+电池充电器

引脚说明

引脚	名称	功能
1	USB	USB 端口充电器电源输入。USB 可提供最高 100mA 的电池充电电流。连接 1μF 陶瓷电容至 GND 为 USB 提供退耦。
2	GND	地
3	$\overline{\text{POK}}$	电源就绪、低电平有效、漏极开路充电器状态指示。接通任何一路电源时， $\overline{\text{POK}}$ 拉低 (仅 MAX1551)。
	$\overline{\text{CHG}}$	低电平有效、漏极开路充电状态指示。当电池充电时 $\overline{\text{CHG}}$ 为低电平。如果 $\overline{\text{CHG}}$ 变为高阻态，表明电池已经充满，此时充电器处于电压模式、充电电流降低至 50mA 以下。当两个输入源均为低电平时， $\overline{\text{CHG}}$ 为高阻态 (仅 MAX1555)。
4	DC	AC 适配器的 DC 充电器电源输入。DC 电源提供 280mA 的电池充电电流。连接 1μF 陶瓷电容至 GND 为 DC 提供退耦。
5	BAT	接电池。连接 1μF 陶瓷电容至 GND 为 BAT 提供退耦。

MAX1551/MAX1555

详细说明

MAX1551/MAX1555 可使用 USB 或 AC 适配器电源对单节 Li+ 电池进行充电，使便携产品的用户无须携带墙上适配器。这些器件工作时无需外部场效应管或二极管，并可工作在高达 7V 的输入电压。

内部温度控制环路简化了 PC 板的布局，并允许优化充电速率，使其在电池状况最差、输入电压最高的情况下不会达到温度限制值；而当 MAX1551/MAX1555 达到温度限制的门槛时，充电器不会关断，而是逐步减小充电电流，电流会按照管芯温度超过 +110°C 的部分以 17mA/°C 的速度降低。

当与 USB 连接、但没有 DC 电源时，充电电流被置为 100mA (最大值)。这样，加电或未加电的 USB 集线器均可用于充电，无需端口通信。当连接了 DC 电源时，充电电流被置为 280mA (典型值)。MAX1551/MAX1555 没有使能输入，只要电源连接到 USB 和/或 DC，充电器就开始工作。

当输入电源被移走时，电池漏电流低于 5μA。无须使用输入屏蔽二极管来防止电池漏电。如果需要在负压输入 (极性相反的适配器插入) 时为电路提供保护，可在 DC (适配器输入) 端插入一个二极管。

表 1、USB 和 DC 输入选择

$V_{DC} > 7V$ OR $V_{USB} > 6V$	$V_{DC} > 3.95V$ AND V_{USB} DON'T CARE	$V_{DC} < 3.52V$ AND $3.95V < V_{USB} < 6V$	V_{DC} AND $V_{USB} < 3.52V$
Exceeds operating input range. Not allowed. See the Absolute Maximum Ratings section.	280mA (typ) charging from DC	100mA (max) charging from USB	Undervoltage lockout

(V_{DC} takes precedence when both inputs are present.)

USB 与适配器电源的切换

MAX1551/MAX1555 可使用 USB 输入或 DC 输入进行充电，但并非同时使用两路电源为电池充电。MAX1551/MAX1555 自动检测有效的输入并用其进行充电。如果两个电源均有效，则优先使用 DC 输入。表 1 详细描述了 DC 和 USB 间的切换。

MAX1551 电源就绪 ($\overline{\text{POK}}$)

MAX1551 的 $\overline{\text{POK}}$ 引脚为低电平有效、漏极开路输出，当 V_{DC} 或 V_{USB} 高于 3.95V 时置为低电平。 $\overline{\text{POK}}$ 可以用作逻辑输出或驱动一个 LED。 $\overline{\text{POK}}$ 指示充电器是否连接了输入电源并正在进行充电。

MAX1555 充电状态 ($\overline{\text{CHG}}$)

MAX1555 的 $\overline{\text{CHG}}$ 引脚为低电平有效、漏极开路充电状态指示输出。当电池正在充电 (无论是 USB 还是 DC 供电) 且充电电流高于 50mA 时， $\overline{\text{CHG}}$ 被拉至低电平。当充电器处在电压模式且充电电流跌至 50mA 以下时， $\overline{\text{CHG}}$ 引脚变为高阻状态，表示电池已充满。当 $\overline{\text{CHG}}$ 变高时，充电过程并不停止。在预充电模式下， $\overline{\text{CHG}}$ 为低电平。

SOT23封装、USB/AC适配器双输入、单节Li+电池充电器

MAX1551/MAX1555

预充电电流

MAX1551/MAX1555的预充电电流可以保护深度放电的电池。如果 V_{BAT} 低于 3V，器件会进入预充电模式，在这种模式下，充电电流被限制为 40mA。

封装温度限制电路

MAX1551/MAX1555片内的温度限制电路简化了PC板的布局，并允许优化充电速率，使其在电池状况最差、输入电压最高的情况下不会达到温度限制值。器件通过降低BAT的功耗防止过热，允许电路板针对紧凑的尺寸和典型的散热条件进行优化设计。当MAX1551/MAX1555达到温度门限时，充电器并不关断，而是逐渐减小充电电流，电流会按照管芯温度超过 +110°C的

部分以 17mA/°C 的速度降低。MAX1551/MAX1555的GND接至一个很大的接地平面，有助于功率消散并保证管芯温度低于温度门限。100mA的USB充电电流不会导致过热问题。

旁路电容

在DC、USB和BAT引脚应使用陶瓷旁路电容，这些电容需要安装在相应引脚的1cm以内，推荐使用X5R或X7R电介质的电容。

芯片信息

TRANSISTOR COUNT: 541
PROCESS: BiCMOS

典型应用电路

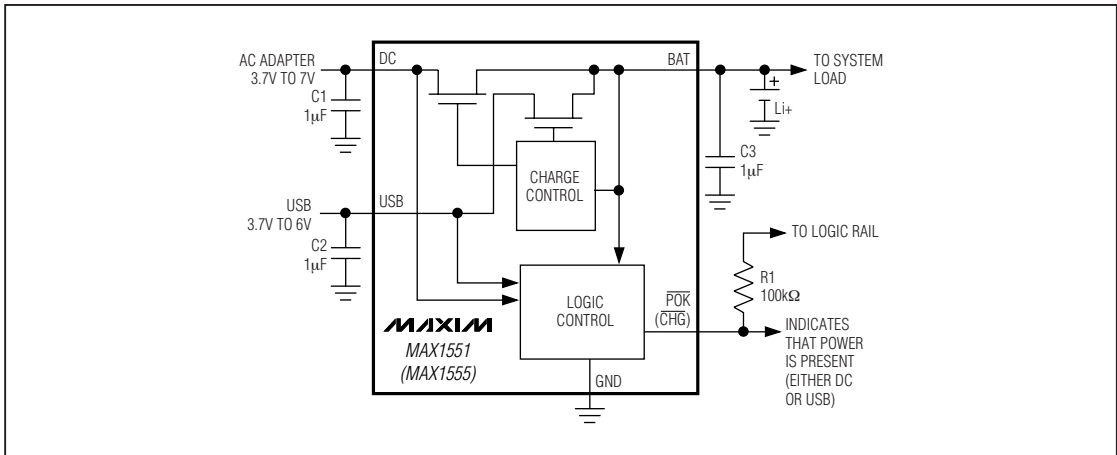

SOT23封装、USB/AC适配器双输入、 单节Li+电池充电器

封装信息

(本数据资料提供的封装图可能不是最近的规格，如需最近的封装外型信息，请查询 www.maxim-ic.com/packages。)

MAX1551/MAX1555

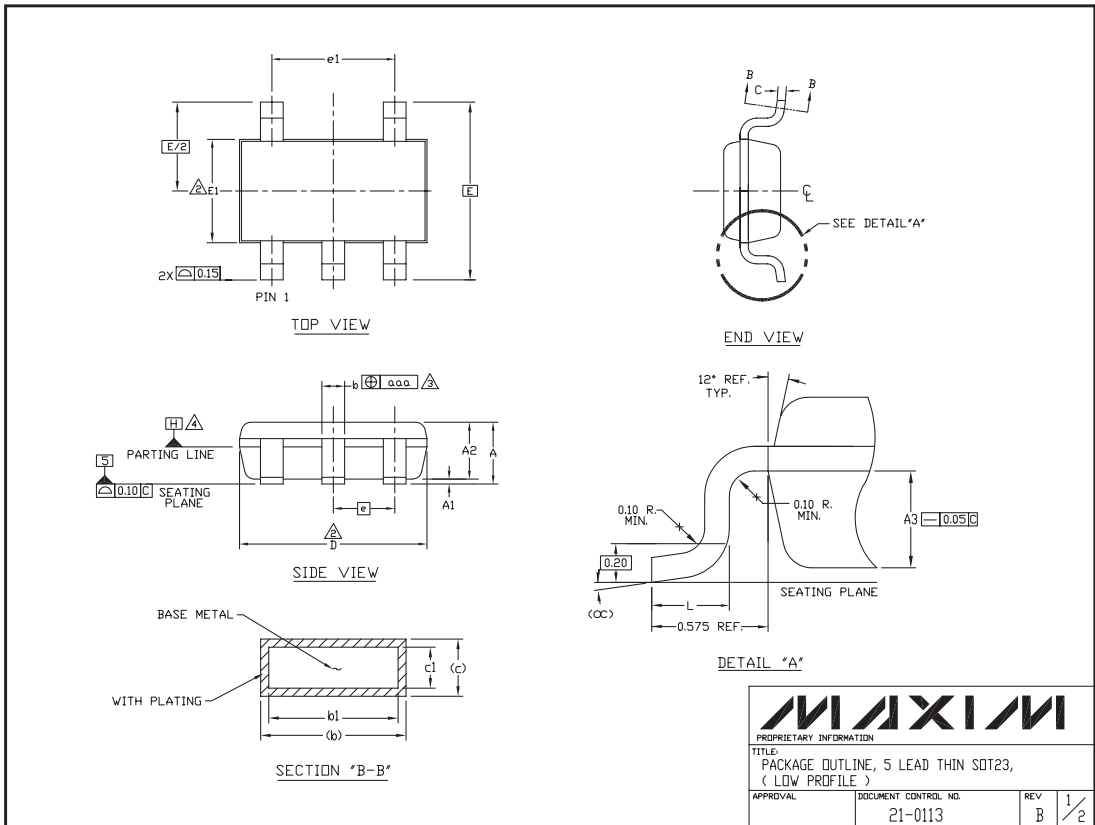

SOT23封装、USB/AC适配器双输入、 单节Li+电池充电器

MAX1551/MAX1555

封装信息 (续)

(本数据资料提供的封装图可能不是最近的规格, 如需最近的封装外型信息, 请查询 www.maxim-ic.com/packages.)

NOTES:

1. ALL DIMENSIONS ARE IN MILLIMETERS.

- ② "D" AND "E1" ARE REFERENCE DATUM AND DO NOT INCLUDE MOLD FLASH OR PROTRUSIONS, AND ARE MEASURED AT THE BOTTOM PARTING LINE. MOLD FLASH OR PROTRUSION SHALL NOT EXCEED 0.15mm ON "D" AND 0.25mm ON "E" PER SIDE.
- ③ THE LEAD WIDTH DIMENSION DOES NOT INCLUDE DAMBAR PROTRUSION. ALLOWABLE DAMBAR PROTRUSION SHALL BE 0.07mm TOTAL IN EXCESS OF THE LEAD WIDTH DIMENSION AT MAXIMUM MATERIAL CONDITION.
- ④ DATUM PLANE "H" LOCATED AT MOLD PARTING LINE AND COINCIDENT WITH LEAD, WHERE LEAD EXITS PLASTIC BODY AT THE BOTTOM OF PARTING LINE.
- ⑤ THE LEAD TIPS MUST LINE WITHIN A SPECIFIED TOLERANCE ZONE. THIS TOLERANCE ZONE IS DEFINED BY TWO PARALLEL LINES. ONE PLANE IS THE SEATING PLANE, DATUM [-C-]; AND THE OTHER PLANE IS AT THE SPECIFIED DISTANCE FROM [-C-] IN THE DIRECTION INDICATED. FORMED LEADS SHALL BE PLANAR WITH RESPECT TO ONE ANOTHER WITH 0.10mm AT SEATING PLANE.
6. THIS PART IS COMPLIANT WITH JEDEC SPECIFICATION MO-193 EXCEPT FOR THE "e" DIMENSION WHICH IS 0.95mm INSTEAD OF 1.00mm. THIS PART IS IN FULL COMPLIANCE TO EIAJ SPECIFICATION SC-74.

SYMBOLS			
	MIN	NOM	MAX
A	-	-	1.10
A1	0.05	0.075	0.10
A2	0.85	0.88	0.90
A3	0.50 BSC		
b	0.30	-	0.45
b1	0.25	0.35	0.40
c	0.15	-	0.20
c1	0.12	0.127	0.15
D	2.80	2.90	3.00
E	2.75 BSC		
E1	1.55	1.60	1.65
L	0.30	0.40	0.50
e1	1.90 BSC		
e	0.95 BSC		
OC	0°	4°	8°
aaa	0.20		

			
PROPRIETARY INFORMATION			
TITLE: PACKAGE OUTLINE, 5 LEAD THIN SOT23, (LOW PROFILE)			
APPROVAL	DOCUMENT CONTROL NO.	REV	2/2
	21-0113	B	

MAXIM北京办事处

北京 8328 信箱 邮政编码 100083
 免费电话: 800 810 0310
 电话: 010-6201 0598
 传真: 010-6201 0298

Maxim 不对 Maxim 产品以外的任何电路使用负责, 也不提供其专利许可。Maxim 保留在任何时间、没有任何通报的前提下修改产品资料和规格的权利。

8 **Maxim Integrated Products, 120 San Gabriel Drive, Sunnyvale, CA 94086 (408) 737-7600**