



三通道DPDT、低电容数据开关

MAX4996/MAX4996L

概述

MAX4996/MAX4996L三路DPDT模拟开关采用+2.5V至+5.5V单电源供电，具有2.0Ω (典型值)导通电阻、极低的导通电容(典型值为6pF)和极低的电源电流损耗。MAX4996/MAX4996L具备了便携式电子产品中高频切换所需的低电容、低电阻特性。

MAX4996/MAX4996L的三个逻辑输入用于控制开关对。MAX4996具有一个高电平有效使能输入(EN)，用于禁止开关切换；MAX4996L则具有一个低电平有效使能输入($\overline{\text{EN}}$)，用于禁止开关切换。使能输入不仅可以降低电源电流，而且可以将COM_输出置于高阻态。

逻辑输入没有达到满摆幅时，MAX4996/MAX4996L的电源电流为5μA (最大值)，这一特性使得该器件非常适合与低压处理器直接连接。

MAX4996/MAX4996L提供节省空间的24引脚(3.5mm x 3.5mm)、TQFN封装，工作在-40°C至+85°C扩展级温度范围。

应用

- SD卡开关
- USB信号开关
- UART信号开关
- 蜂窝电话
- PDA
- GPS
- 便携式媒体播放器(PMP)

订购信息

PART	PIN-PACKAGE	PACKAGE CODE
MAX4996ETG+	24 TQFN-EP*	T243A3-1
MAX4996LETG+	24 TQFN-EP*	T243A3-1

注：所有器件工作在-40°C至+85°C扩展级温度范围。
+表示无铅封装。
*EP = 裸焊盘。

典型工作电路在数据资料的最后给出。

特性

- ◆ 复用SD2.0/SDIO接口
- ◆ 低功耗(最大值为2μA)
- ◆ +2.5V至+5.5V电源电压范围
- ◆ 可处理满摆幅信号
- ◆ 6pF (典型值)低电容开关
- ◆ 2Ω (典型值)低导通电阻
- ◆ 在0V至V_{CC}范围内具有出色的导通电阻平坦度
- ◆ 较宽的-3dB带宽，670MHz
- ◆ 小型24引脚TQFN (3.5mm x 3.5mm)

引脚配置/真值表

TOP VIEW

TQFN
3.5mm x 3.5mm
($\overline{\text{EN}}$) FOR MAX4996L ONLY.
*CONNECT EXPOSED PADDLE TO GROUND.

TRUTH TABLES

CB12	NO1/NO2	NC1/NC2
LOW	OFF	ON
HIGH	ON	OFF
CB34	NO3/NO4	NC3/NC4
LOW	OFF	ON
HIGH	ON	OFF
CB56	NO5/NO6	NC5/NC6
LOW	OFF	ON
HIGH	ON	OFF

EN	CB_	NO_	NC_
HIGH	LOW	OFF	ON
HIGH	HIGH	ON	OFF
LOW	X	OFF	OFF

$\overline{\text{EN}}$	CB_	NO_	NC_
LOW	LOW	OFF	ON
LOW	HIGH	ON	OFF
HIGH	X	OFF	OFF



三通道DPDT、低电容数据开关

MAX4996/MAX4996L

ABSOLUTE MAXIMUM RATINGS

V _{CC} to GND	-0.3V to +6.0V	Continuous Power Dissipation (T _A = +70°C) 24-Pin TQFN (derate 20.8mW/°C above +70°C).....	1228mW
EN, $\overline{\text{EN}}$, CB_	-0.3V to +6.0V	Thermal Resistance (Note 1)	
All Other Pins to GND	-0.3V to V _{CC} + 0.3V	θ _{JA}	65.1°C/W
Continuous Current		θ _{JC}	5.4°C/W
NO_, NC_, COM_	±150mA	Operating Temperature Range	-40°C to +85°C
Peak Current NO_, NC_, COM_		Junction Temperature.....	+150°C
(pulsed at 1ms, 50% Duty Cycle).....	±300mA	Storage Temperature Range	-65°C to +150°C
(pulsed at 1ms, 10% Duty Cycle).....	±450mA	Lead Temperature (soldering).....	+300°C
ESD per Human Body Model.....	±2kV		

Note 1: Package thermal resistances were obtained using the method described in JEDEC specification JESD51-7, using a four-layer board. For detailed information on package thermal considerations see www.maxim-ic.com.cn/thermal-tutorial.

Stresses beyond those listed under "Absolute Maximum Ratings" may cause permanent damage to the device. These are stress ratings only, and functional operation of the device at these or any other conditions beyond those indicated in the operational sections of the specifications is not implied. Exposure to absolute maximum rating conditions for extended periods may affect device reliability.

ELECTRICAL CHARACTERISTICS

(V_{CC} = +2.5V to +5.5V, T_A = -40°C to +85°C, unless otherwise noted. Typical values are at V_{CC} = 2.8V, T_A = +25°C.) (Notes 2, 3)

PARAMETER	SYMBOL	CONDITIONS	MIN	TYP	MAX	UNITS
ANALOG SWITCH						
Analog Signal Range	V _{COM} , V _{NO} , V _{NC}		0		V _{CC}	V
On-Resistance	R _{ON}	V _{COM} = 0 to V _{CC} , I _{COM} = 25mA		2	4	Ω
On-Resistance Match Between Channels	ΔR _{ON}	V _{CC} = 2.8V, I _{COM} = 25mA; V _{NO} = 1.5V or V _{NC} = 1.5V (Note 4)		0.1	0.2	Ω
On-Resistance Flatness	R _{FLAT}	V _{CC} = 2.5V, I _{COM} = 25mA; V _{COM} = 0 to V _{CC} (Note 5)		0.2	0.5	Ω
Off-Leakage Current	I _{COM} (OFF)	V _{CC} = 4V, V _{COM} = 0, 4V; V _{NO} , V _{NC} = 4V, 0	-250		+250	nA
		V _{CC} = 5.5V, V _{COM} = 5.5V; V _{NO} , V _{NC} with 50μA sink current to GND			180	μA
On-Leakage Current	I _{COM} (ON)	V _{CC} = 5.5V, V _{COM} = 0, 5.5V; V _{NO} , V _{NC} unconnected	-250		+250	nA
-3dB Bandwidth	BW	R _L = R _S = 50Ω, C _L = 5pF, Figure 4		670		MHz
Off-Isolation	V _{ISO}	f = 1MHz, V _{NO} , V _{NC} = 0; C _L = 5pF, R _L = R _S = 50Ω, Figure 4 (Note 6)		-60		dB
Crosstalk	V _{CT}	f = 1MHz, V _{NO} , V _{NC} = 0; R _L = R _S = 50Ω, Figure 4 (Note 7)		-120		dB
LOGIC INPUTS						
Input Logic High	V _{IH}		1.4			V
Input Logic Low	V _{IL}				0.5	V
Input Leakage Current	I _{LEAK}	0 ≤ V ≤ V _{IL} and V _{IH} ≤ V ≤ V _{CC} ; V _{CC} = 5.5V	-250		+250	nA

三通道DPDT、低电容数据开关

MAX4996/MAX4996L

ELECTRICAL CHARACTERISTICS (continued)

(V_{CC} = +2.5V to +5.5V, T_A = -40°C to +85°C, unless otherwise noted. Typical values are at V_{CC} = 2.8V, T_A = +25°C.) (Notes 2, 3)

PARAMETER	SYMBOL	CONDITIONS	MIN	TYP	MAX	UNITS
SWITCH DYNAMICS						
Turn-On Time	t _{ON}	V _{CC} = 2.7V, V _{NO_} or V _{N C_} = 1.5V; R _L = 50Ω, C _L = 35pF, Figure 1			100	μs
Turn-Off Time	t _{OFF}	V _{CC} = 2.7V, V _{NO_} or V _{N C_} = 1.5V; R _L = 50Ω, C _L = 35pF, Figure 1			6	μs
Break-Before-Make Interval	t _{B B M}	V _{CC} = 2.7V; V _{NO_} or V _{N C_} = 1.5V; R _L = 50Ω, C _L = 35pF, Figure 2		10		μs
Output Skew Between Switches	t _{S K E W}	R _L = R _S = 50Ω, Figure 3		40		Ps
NO or NC Off-Capacitance	C _{N O_ (OFF)} C _{N C_ (OFF)}	f = 10MHz, V _{B I A S} = 0V, signal = 500mV _{P-P} , Figure 5		2.5		pF
COM Off-Capacitance	C _{C O M_ (OFF)}	f = 10MHz, V _{B I A S} = 0V, signal = 500mV _{P-P} , Figure 5		4		pF
COM On-Capacitance	C _{C O M_ (ON)}	f = 10MHz, V _{B I A S} = 0V, signal = 500mV _{P-P} , Figure 5		6		pF
Operating Power-Supply Range	V _{CC}		2.5		5.5	V
Shutdown Supply Current		V _{E N} = 0 (MAX4996), V _{E N} = V _{CC} (MAX4996L)		0.1	0.5	μA
V _{CC} Supply Current	I _{CC}	V _{C B_} = 0 or V _{CC} ; V _{E N} = V _{CC} (MAX4996); V _{E N} = 0 (MAX4996L)	V _{CC} = 2.8V	1	2	μA
			V _{CC} = 5.5V	5	10	
Increase in Supply Current with V _{CB} / V _{EN} Voltage		0 ≤ V _{C B_} ≤ V _{I L} or V _{I H} ≤ V _{C B_} ≤ V _{CC} or 0 ≤ V _{E N} ≤ V _{I L} or V _{I H} ≤ V _{E N} ≤ V _{CC}			5	μA
ESD Protection		Human Body Model		±2		kV

Note 2: The algebraic convention is used. The most negative value is shown in the minimum column.

Note 3: Parts are 100% tested at T_A = +25°C. Limits across the full temperature range are guaranteed by correlation and design.

Note 4: ΔRON = RON(MAX) - RON(MIN).

Note 5: Flatness is defined as the difference between the maximum and minimum value of on-resistance as measured over the specified analog signal ranges.

Note 6: Off-isolation = 20log₁₀ [V_{C O M_} / (V_{N O_} or V_{N C_})], V_{C O M_} = output, V_{N O_} or V_{N C_} = input to off switch.

Note 7: Between any two switches.

三通道DPDT、低电容数据开关

MAX4996/MAX4996L

典型工作特性

($V_{CC} = 3V$, $T_A = +25^\circ C$, unless otherwise noted.)

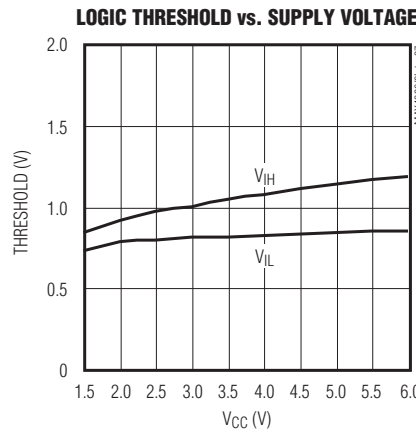
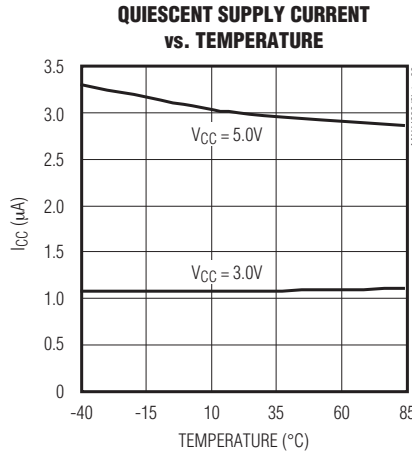
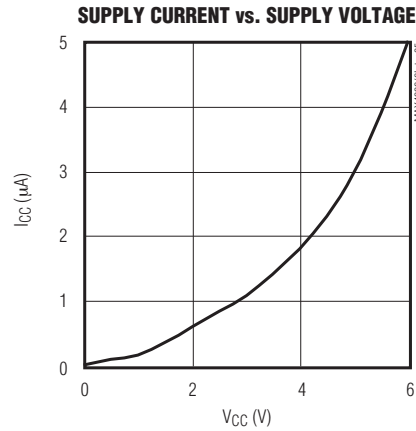
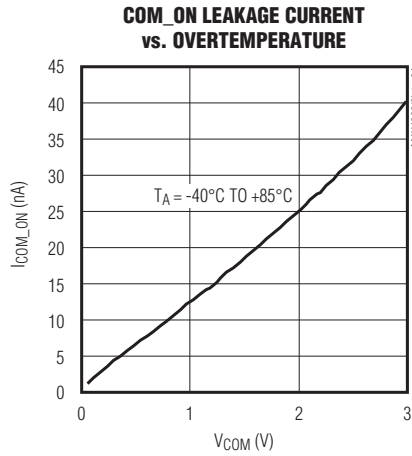
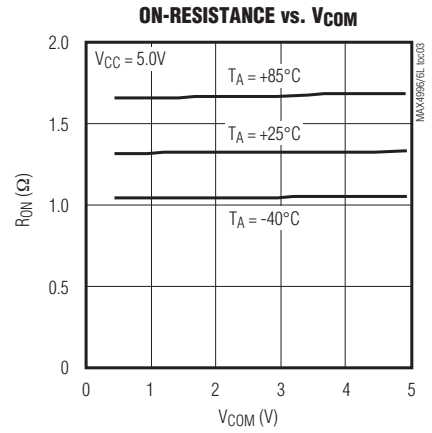
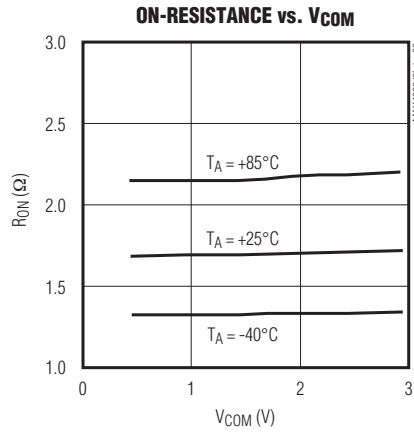
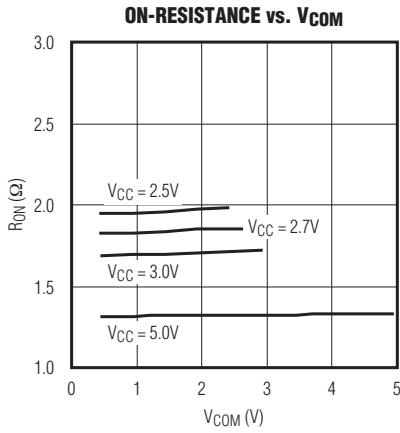

三通道DPDT、低电容数据开关

典型工作特性(续)

($V_{CC} = 3V$, $T_A = +25^\circ C$, unless otherwise noted.)

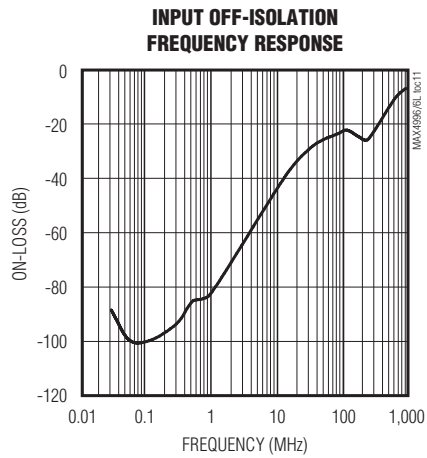
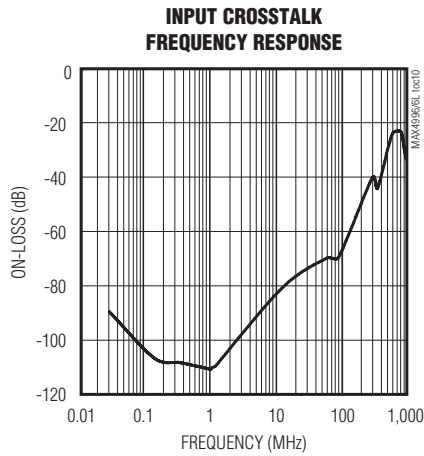
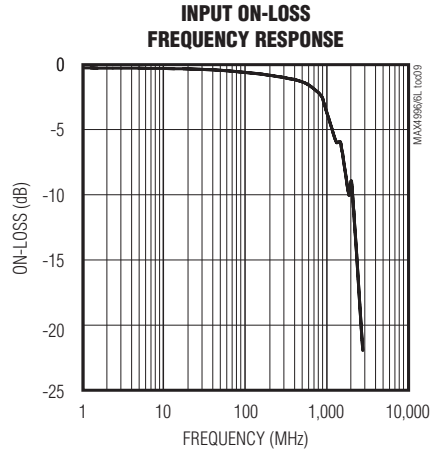
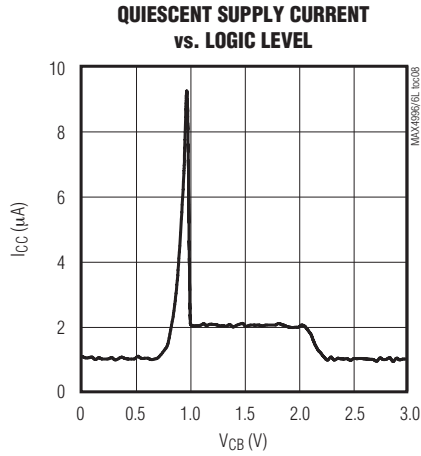

MAX4996/MAX4996L

三通道DPDT、低电容数据开关

MAX4996/MAX4996L

引脚说明

引脚	名称	功能
1	CB12	模拟开关1和2的数字控制输入。驱动CB12至低电平，将COM1连接至NC1，COM2连接至NC2；驱动CB12至高电平，将COM1连接至NO1，COM2连接至NO2。
2	CB34	模拟开关3和4的数字控制输入。驱动CB34至低电平，将COM3连接至NC3，COM4连接至NC4；驱动CB34至高电平，将COM3连接至NO3，COM4连接至NO4。
3	CB56	模拟开关5和6的数字控制输入。驱动CB56至低电平，将COM5连接至NC5，COM6连接至NC6；驱动CB56至高电平，将COM5连接至NO5，COM6连接至NO6。
4	COM4	模拟开关4—公共端。
5	COM5	模拟开关5—公共端。
6	COM6	模拟开关6—公共端。
7	NC6	模拟开关6—常闭端。
8	NC5	模拟开关5—常闭端。
9	NC4	模拟开关4—常闭端。
10	NC3	模拟开关3—常闭端。
11	NC2	模拟开关2—常闭端。
12	NC1	模拟开关1—常闭端。
13	GND	地。
14	V _{CC}	正电源电压。采用0.1μF陶瓷电容将V _{CC} 旁路至GND，电容应尽可能靠近器件放置。
15	EN, $\overline{\text{EN}}$	使能逻辑输入。对于MAX4996，驱动EN至高电平，使能所有开关；驱动EN至低电平，禁止所有开关。对于MAX4996L，驱动 $\overline{\text{EN}}$ 至低电平，使能所有开关；驱动 $\overline{\text{EN}}$ 至高电平，禁止所有开关。开关禁止时，COM_端为高阻态。(参见引脚配置/真值表。)
16	COM3	模拟开关3—公共端。
17	COM2	模拟开关2—公共端。
18	COM1	模拟开关1—公共端。
19	NO1	模拟开关1—常开端。
20	NO2	模拟开关2—常开端。
21	NO3	模拟开关3—常开端。
22	NO4	模拟开关4—常开端。
23	NO5	模拟开关5—常开端。
24	NO6	模拟开关6—常开端。
—	EP	裸焊盘。内部连接至GND，将其连接至大面积地平面有助于改善散热，不要将其作为电气连接点。

三通道DPDT、低电容数据开关

测试电路/时序图

MAX4996/MAX4996L



图1. 开关时间



图2. 先断后合的间隔

三通道DPDT、低电容数据开关

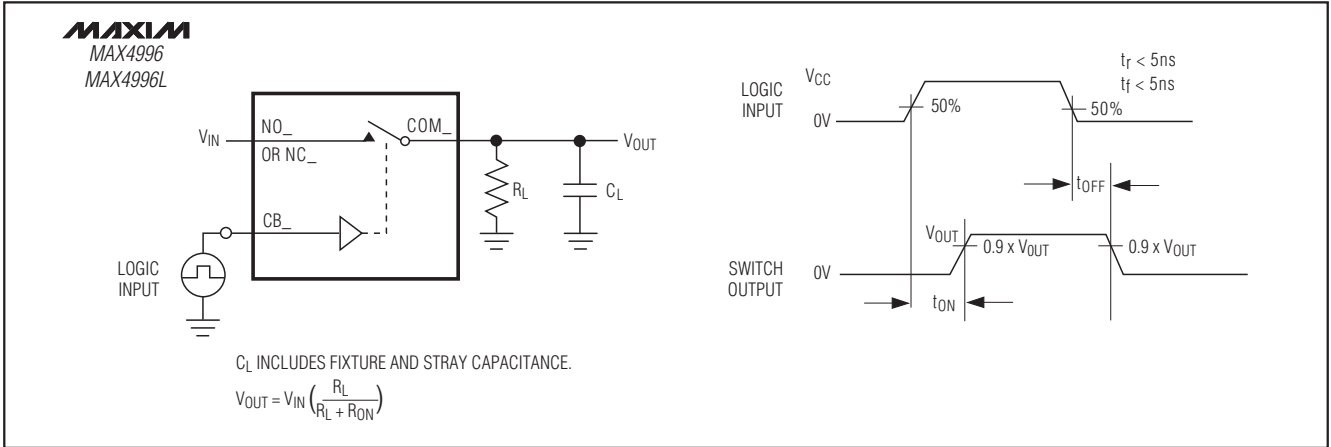
MAX4996/MAX4996L

测试电路/时序图(续)

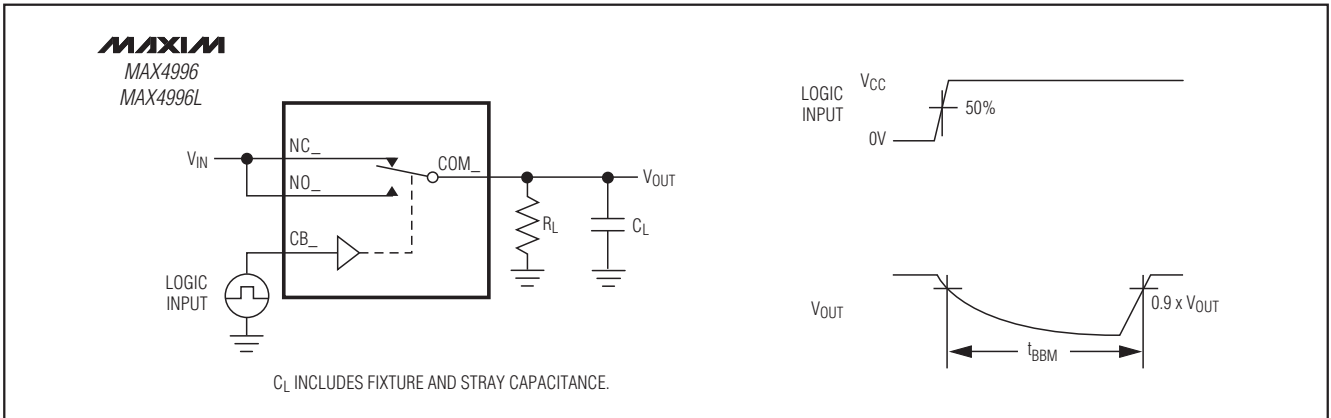

图3. 输入/输出偏差时序图

三通道DPDT、低电容数据开关

测试电路/时序图(续)

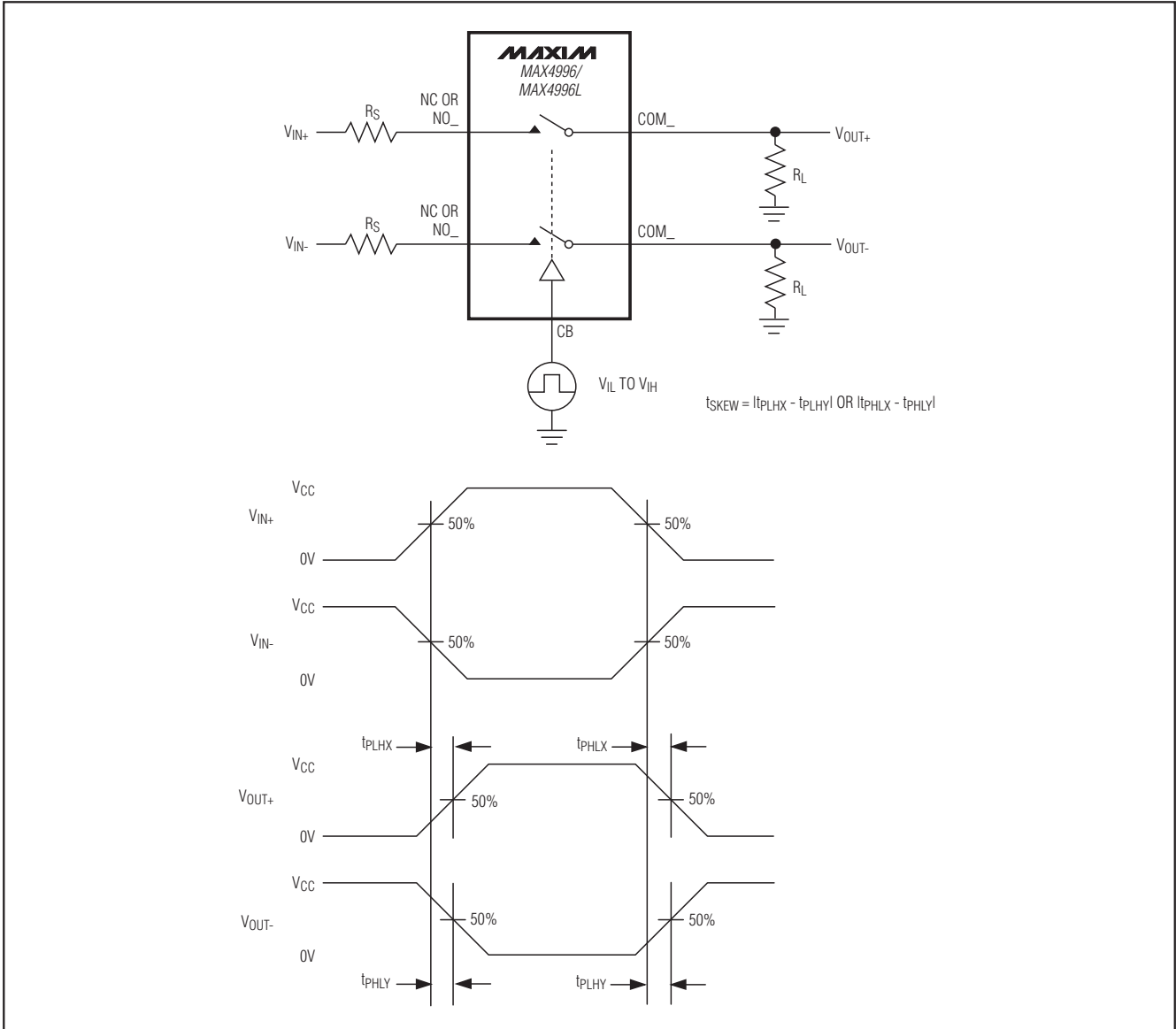

图4. 导通损耗、关断隔离和串扰



图5. 通道通/断电容

MAX4996/MAX4996L

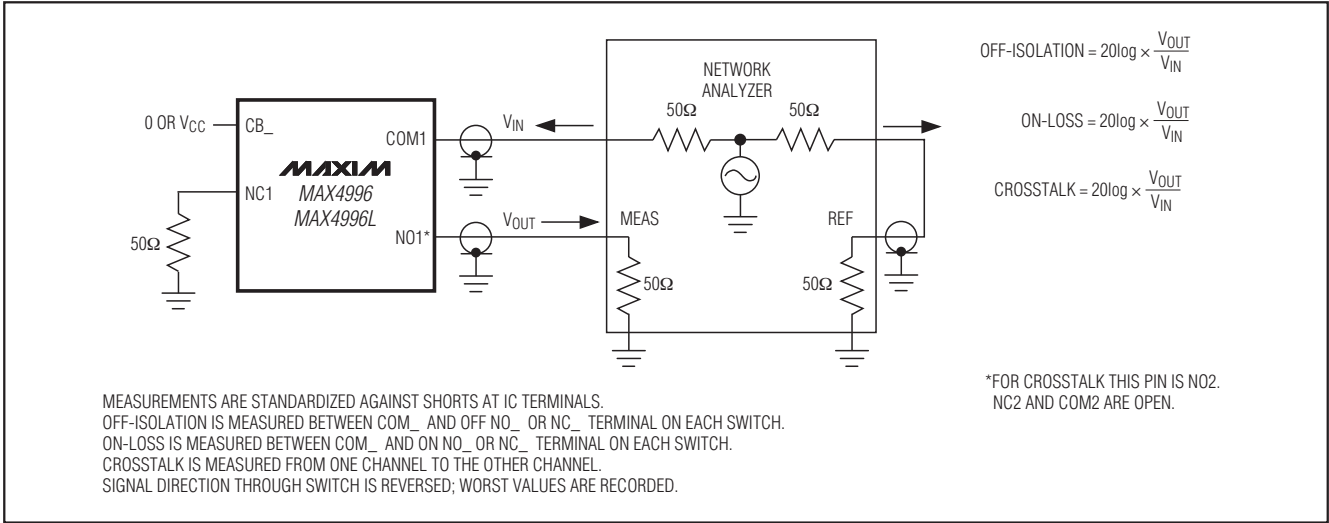
三通道DPDT、低电容数据开关

MAX4996/MAX4996L

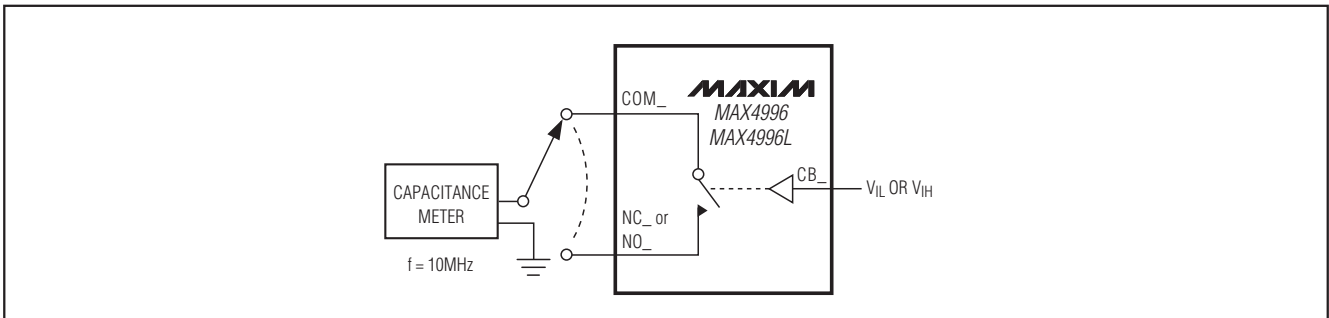
详细说明

MAX4996/MAX4996L三路DPDT模拟开关采用+2.5V至+5.5V单电源供电，具有 2.0Ω (典型值)导通电阻、极低的导通电容(典型值为6pF)和极低的电源电流损耗。低电阻和低电容特性，使开关非常适合高频应用。

MAX4996具有一个高电平有效使能输入(EN)，用于禁止开关；MAX4996L则具有一个低电平有效使能输入(\overline{EN})，用于禁止开关。使能输入不仅可以降低电源电流，而且可以将COM_输出置于高阻态。

数字控制输入

每对开关均具有一个数字控制逻辑输入CB_。CB_控制开关的位置，如引脚配置/真值表所示。MAX4996/MAX4996L还具有一个可以闭合或断开所有开关的使能输入。驱动MAX4996的EN至低电平或MAX4996L的 \overline{EN} 至高电平，可以禁止开关切换。开关禁止时为高阻态，电源电流降至 $0.1\mu A$ (典型值)。将MAX4996的EN驱动至高电平或将MAX4996L的 \overline{EN} 驱动至低电平，将使能所有开关。

满摆幅驱动数字输入(CB_、EN、 \overline{EN})时，电源电流最小。

模拟信号电平

MAX4996/MAX4996L具有非常低的导通电阻，并在模拟输入信号从地电位至 V_{CC} 的整个变化范围内保持稳定(参见典型工作特性)。这些开关可双向工作，因此NO_、NC_和COM_既可作为输入也可作为输出。

应用信息

电源旁路

电源旁路能够提高噪声容限，防止开关噪声通过 V_{CC} 电源耦合到其它器件。在 V_{CC} 和GND之间连接一只 $0.1\mu F$ 陶瓷电容即可满足大多数应用要求。

电源排序

要求 V_{CC} 始终在加载模拟信号前施加。

功能框图

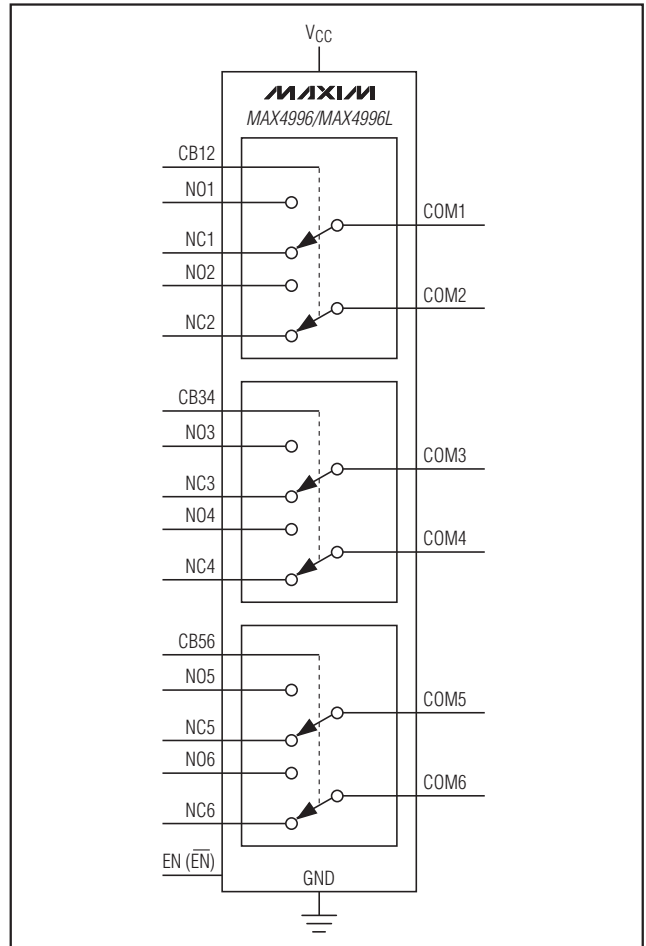

芯片信息

PROCESS: BiCMOS

三通道DPDT、低电容数据开关

典型工作电路

MAX4996/MAX4996L

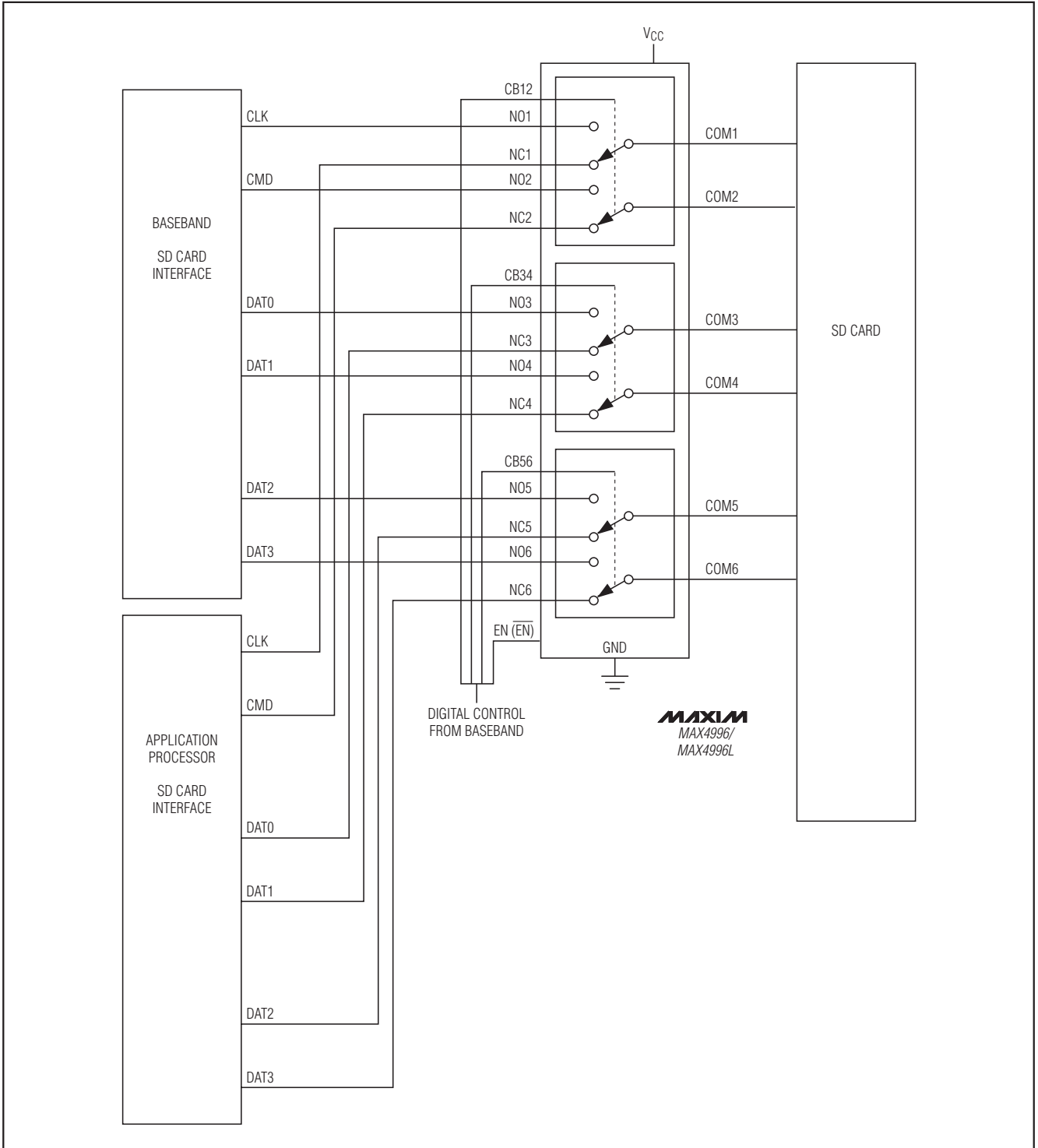

三通道DPDT、低电容数据开关

MAX4996/MAX4996L

封装信息

(本数据资料提供的封装图可能不是最近的规格, 如需最近的封装外形信息, 请查询 www.maxim-ic.com.cn/packages.)

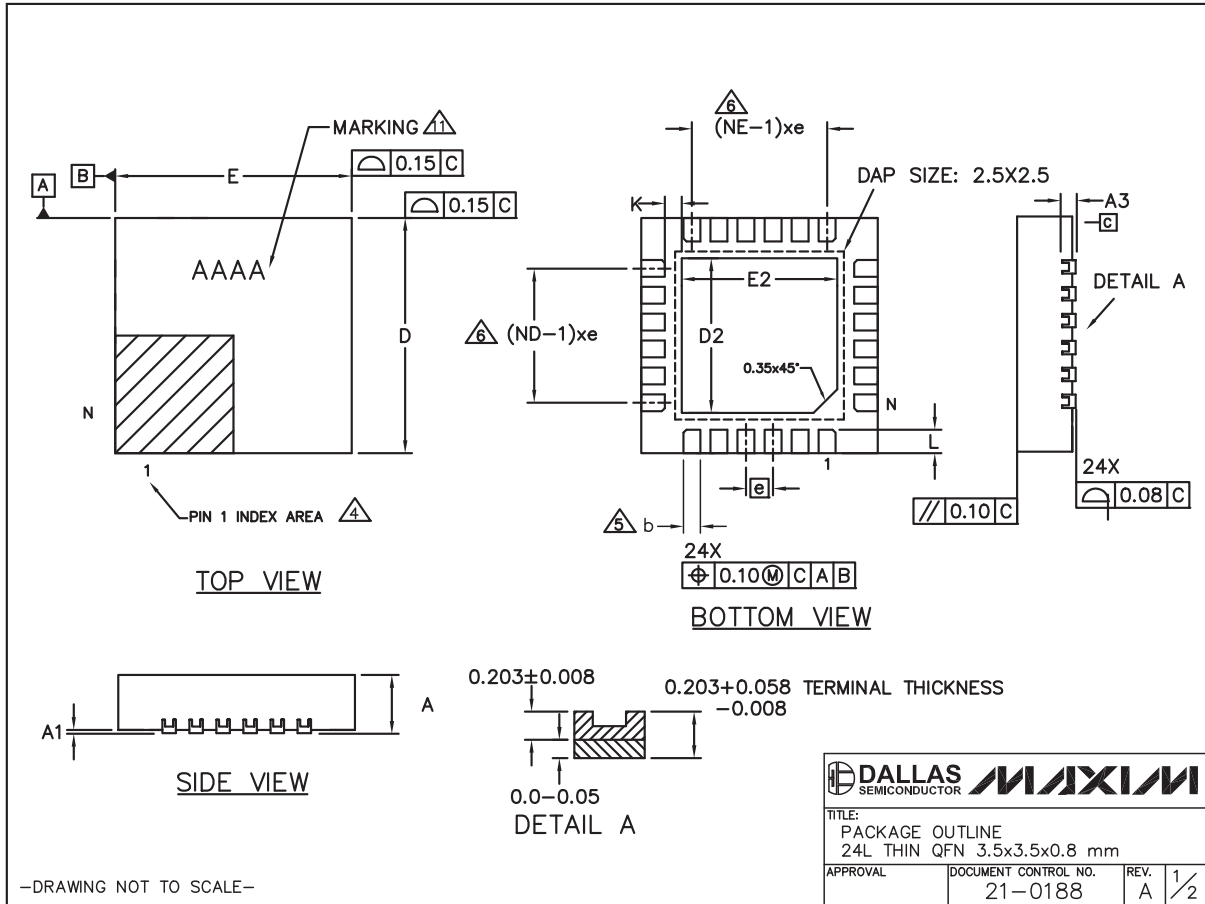

24L THIN QFN EPS

-DRAWING NOT TO SCALE-

三通道DPDT、低电容数据开关

封装信息(续)

(本数据资料提供的封装图可能不是最近的规格, 如需最近的封装外形信息, 请查询 www.maxim-ic.com.cn/packages.)

MAX4996/MAX4996L

NOTES:

1. DIMENSIONING & TOLERANCING CONFORM TO ASME Y14.5M-1994.
2. ALL DIMENSIONS ARE IN MILLIMETERS. ANGLES ARE IN DEGREES.
3. N IS THE TOTAL NUMBER OF TERMINALS.

⚠ THE TERMINAL #1 IDENTIFIER AND TERMINAL NUMBERING CONVENTION SHALL CONFORM TO JESD 95-1 SPP-012. DETAILS OF TERMINAL #1 IDENTIFIER ARE OPTIONAL, BUT MUST BE LOCATED WITHIN THE ZONE INDICATED. THE TERMINAL #1 IDENTIFIER MAY BE EITHER A MOLD OR MARKED FEATURE.

⚠ DIMENSION b APPLIES TO METALLIZED TERMINAL AND IS MEASURED BETWEEN 0.25mm AND 0.30mm FROM TERMINAL TIP.

⚠ ND AND NE REFER TO THE NUMBER OF TERMINALS ON EACH D AND E SIDE RESPECTIVELY.

7. DEPOPULATION IS POSSIBLE IN A SYMMETRICAL FASHION.
8. COPLANARITY APPLIES TO THE EXPOSED HEAT SINK SLUG AS WELL AS THE TERMINALS.
9. REFER TO JEDEC MO-220 EXCEPT D2, E2, & L DIMENSIONS.
10. WARPAGE SHALL NOT EXCEED 0.10mm.

⚠ MARKING IS FOR PACKAGE ORIENTATION PURPOSE ONLY.

COMMON DIMENSION				NOTE
REF.	MIN.	NOM.	MAX.	
A	0.70	0.75	0.80	
A1	0	-	0.05	
A3	0.20 REF			
b	0.15	0.20	0.25	
D	3.40	3.50	3.60	
E	3.40	3.50	3.60	
e	0.40 BSC.			
K	0.25	-	-	
L	0.30	0.35	0.40	
N	24			
ND	6			
NE	6			

	D2			E2		
	MIN.	NOM.	MAX.	MIN.	NOM.	MAX.
T243A3-1	2.20	2.30	2.40	2.20	2.30	2.40

—DRAWING NOT TO SCALE—

TITLE: PACKAGE OUTLINE 24L THIN QFN 3.5x3.5x0.8 mm	
APPROVAL	DOCUMENT CONTROL NO. 21-0188 REV. A 2/2

Maxim北京办事处

北京 8328信箱 邮政编码 100083
 免费电话: 800 810 0310
 电话: 010-6211 5199
 传真: 010-6211 5299

Maxim不对Maxim产品以外的任何电路使用负责, 也不提供其专利许可。Maxim保留在任何时间、没有任何通报的前提下修改产品资料和规格的权利。

Maxim Integrated Products, 120 San Gabriel Drive, Sunnyvale, CA 94086 408-737-7600 13