

●新特器件应用

池 Li 离子 NiMH 和 Nicd 电流充电器 MAX846

西安电子科技大学 226#信箱 蔡朝阳

摘要: MAX846 既可以单独对 Li+ 电池充电, 也可以与廉价 μP 相结合, 组成适用于多种电池的充电系统。该电路内含独立的电压和电流回路, 易于控制, 内置 0.5% 的基准, 增加了充电设备的安全可靠性, 内置 LDO 及具有复位功能的 PWROK 简化了电路设计, 可降低系统成本。

关键词: 充电系统核心 微控制器 MAX846A

1、性能简述

MAX846A 是美国 MAXIM 公司新推出的低成本、多种化学电池充电器的系统核心, 既可单独对 Li+ 电池充电, 也可以与低成本微控制器组成通用充电系统, 内置精度为 0.5% 的高精密电压基准, 为整个系统安全可靠的工作提供了保障, 其内部还含有一个精度为 1%、输出电压为 3.3V 的线性稳压器, 可为外接微控制器及 ADC 供电并提供基准。

MAX846 以上特点将大大简化设计过程, 节省空间的 QSOP 封装。可让您轻易的将其用于任何便携设备的电池电源系统。

2、管脚说明

MAX846A 内部结构如图 1 所示, 管脚排列如图 2 所示, 各引脚详细功能如表 1 所列。

3、设计参考

便携式设备电源系统的设计, 除了要求所占空间尽可能小外还应具备效率高、易于控制、适用于多种电池等特点, 尽可能避免对同一性能电路的重复设计。MAX846 可进一步简化便携设备的电源系统设计, 它可以对 Li+、NiCd、NiMH 等多种电池充电, 可方便

的用于如大哥大、笔记本电脑的电池充电系统中。

由 MAX846 组成的典型 Li+ 电池充电



图 1 MAX846 内部结构



图 2 MAX846A 封装图

表1 MAX846 引脚定义

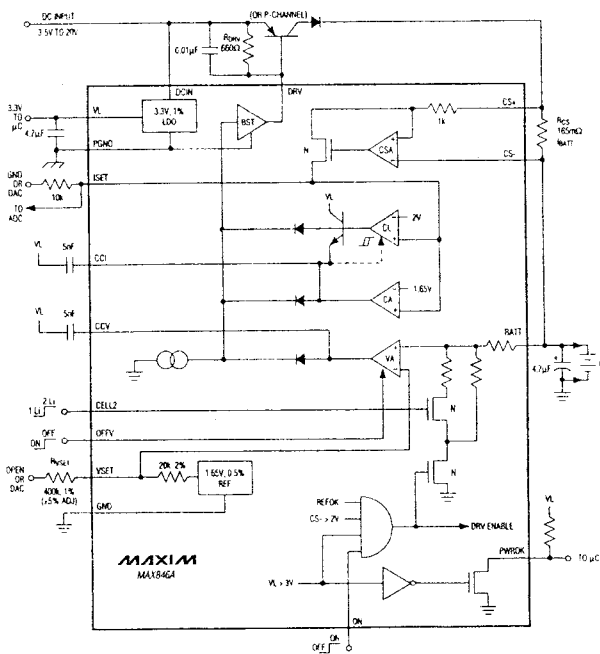
引脚	符号	功能描述
1	DCIN	电源输入 $3.7V \leq DCIN \leq 21V$
2	VL	基准电压输出, 精度为 1%, 输出电压为 3.3V, 最大输出电流为 20mA, 采用 LDO 输出。
3	CCI	电流调整回路补偿端与 V_L 之间接 5~10nF 电容
4	GND	系统地
5	CCV	电压调整回路补偿端, 与 V_L 之间接 5~10nF 电容
6	VSET	充电电压调整端
7	ISET	电流设置输入/电流监控输出
8	OFFV	电压环路截止控制端, 高电平时截止, 为 NiCd NiMH 充电。
9	PWROK	为微控制器提供复位, 当 $V_L < 3V$ 时, 该管脚为低。
10	CELL2	定义 Li+ 电池数目, CELL2 接 V_L 为 2 节。
11	ON	ON/OFF
12	BATT	电池正极
13	CS+	电流传感器高端输入
14	CS-	电流传感器低端输入
15	PGND	电源地
16	DRV	PNP 管或 P 沟道场效应管驱动, 只吸收电流最佳电流。设置为 1mA (PNP 管的 $R_{DRV} = 660\Omega$), 详见典型电路。

器如图 3 所示, 其充电曲线如图 4 所示。

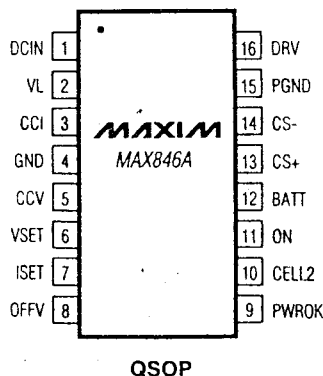
以上典型电路设计过程如下:

● 定义充电电池数目:

数目 GND VL
CELL2 1 2

● 定义浮动电压 V_F : 根据电池特性确定 V_F , 笔者选 $V_F = 4.5V$, 由 V_F 确定 V_{VSET} 所接电阻 R_{VSET} 。

$$R_{VSET} = \frac{\left(\frac{4.2}{1.65} V_X - V_F \right)}{(V_F - 4.2)} 20k\Omega$$

$V_X = 0$ 或 V_L , $\therefore V_F > 4.2$, $\therefore V_X$ 选 V_L , 计算得出 $R_{VSET} = 260k\Omega$

当选取 $V_F = 4.2V$ 时, V_{SET} 引脚不接

● R_{CS} 与 R_{ISET} 的选取计算: 因为电流调整环路将维持 I_{SET} 点电压 $V_{ISET} = 1.65V$, 所以 $R_{CS} = V_{CS} / I_{BATT}$

$$R_{ISET} (k\Omega) = 1.65V / V_{CS}$$

选 I_{BATT} 为 1A, 为便于计算, 选 $V_{CS} = 0.165V$, $\therefore R_{ISET} = 1.65 / 0.165k\Omega = 10k\Omega$, $R_{CS} = 0.165 / 1 = 0.165\Omega$ 。



图3 用 MAX846 组成的 Li+ 电池充电器电路



图4 MAX846 充电曲线(Li+)

以上数据仅供参考，设计时可根据具体情况另行计算。

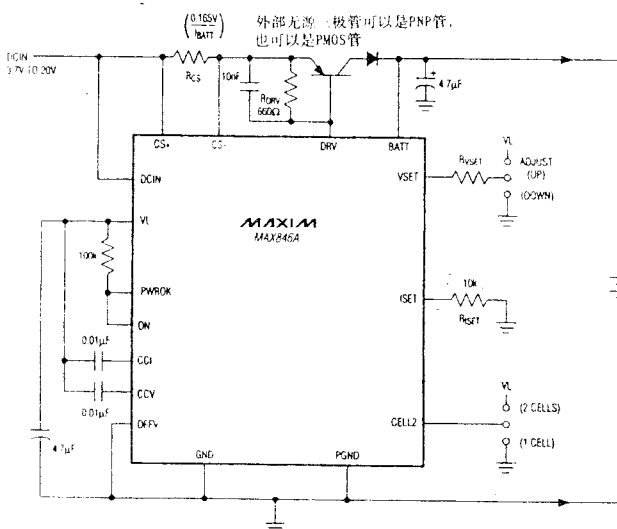
由 MAX846A 组成的与微控制器接口的典型电路如图 5 所示。

该电路所组成的充电器可对 Li⁺、

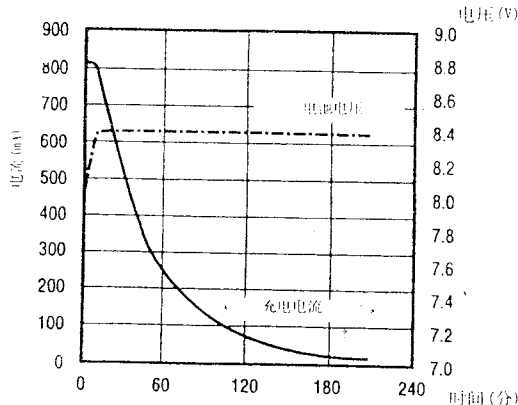
NiCd、NiMH 等电池时进行充电，电路中与控制微控制器接口部分详见图 6、图 7 所示。

以上只是对 MAX846 典型设计的概述，其具体电路因篇幅所限，不一一介绍了。

咨询编号: 970602



图 5 与 μP 接口的 MAX846 电路



图 6 与带 PWM 的微处理器的接口电路

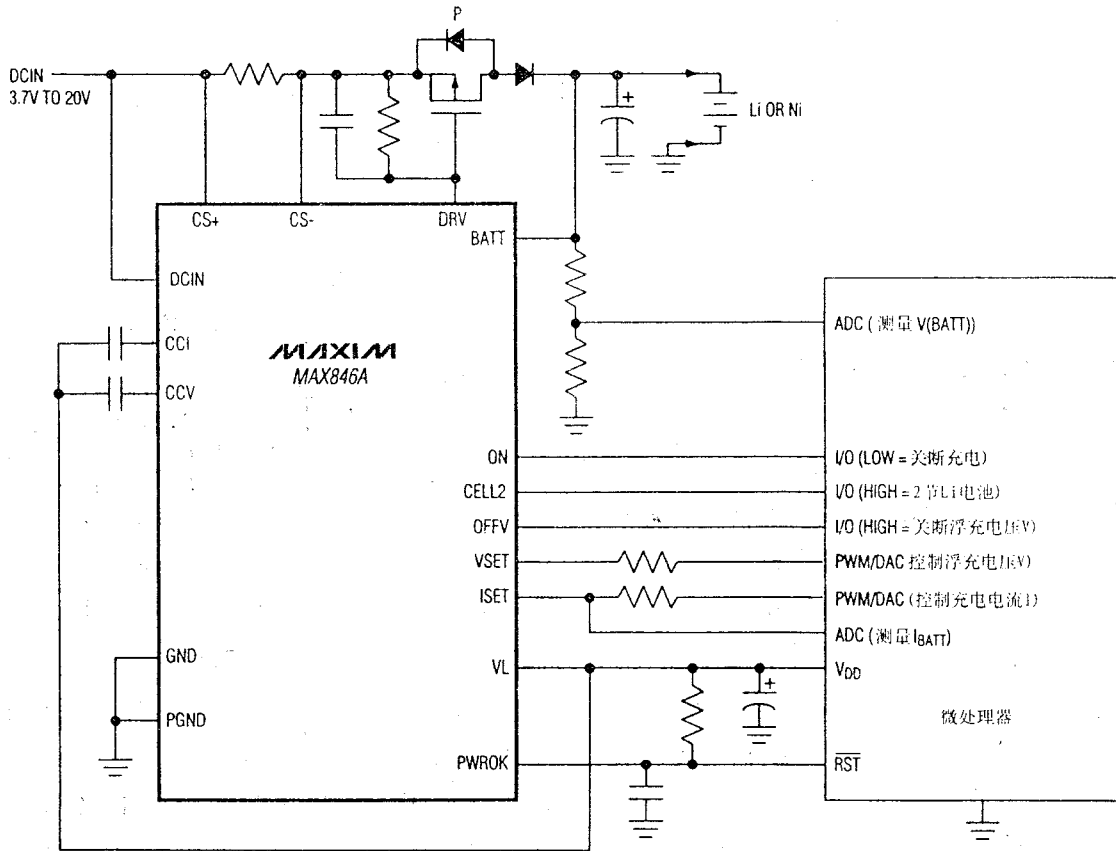

图 7 与带输出电流 DAC 的微处理器的接口电路

完善的电池 充电系统可节省成本

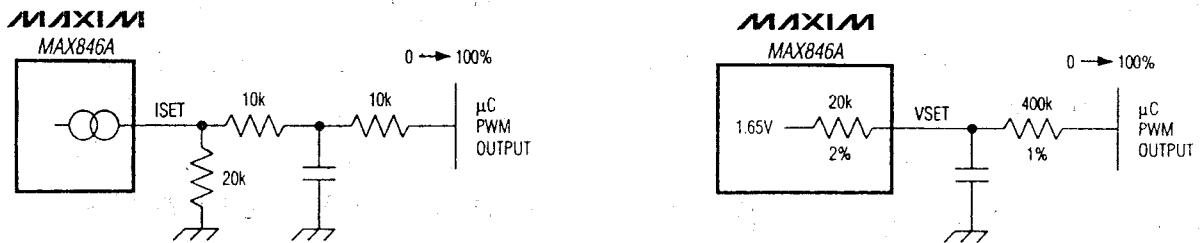
以独立的电压电流回路为Li+、NiMH或NiCd电池充电

MAX846是低成本而又适用于多种化学结构电池的充电器模组。它采用独立的电压和电流回路，可以灵活地为锂离子、镍氢合金或镍镉电池充电。它可以单独用作Li+充电器，也可以与低成本微控制器配合，作为一个通用充电器。其内置0.5%基准可以安全地为锂电充电。可以由内装1%线性调节器为任意的微控制器供电，并为其模数转换器提供基准。此外并有免费的板上复位附件，向微控制器报知功率意外损耗。

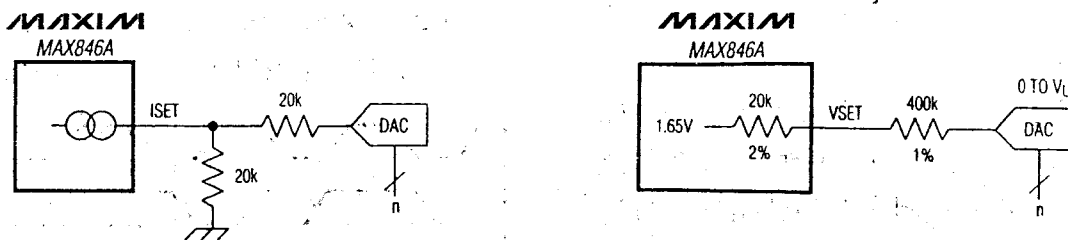
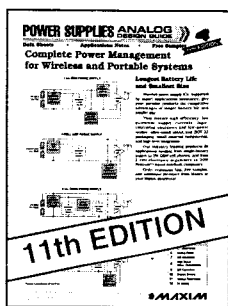
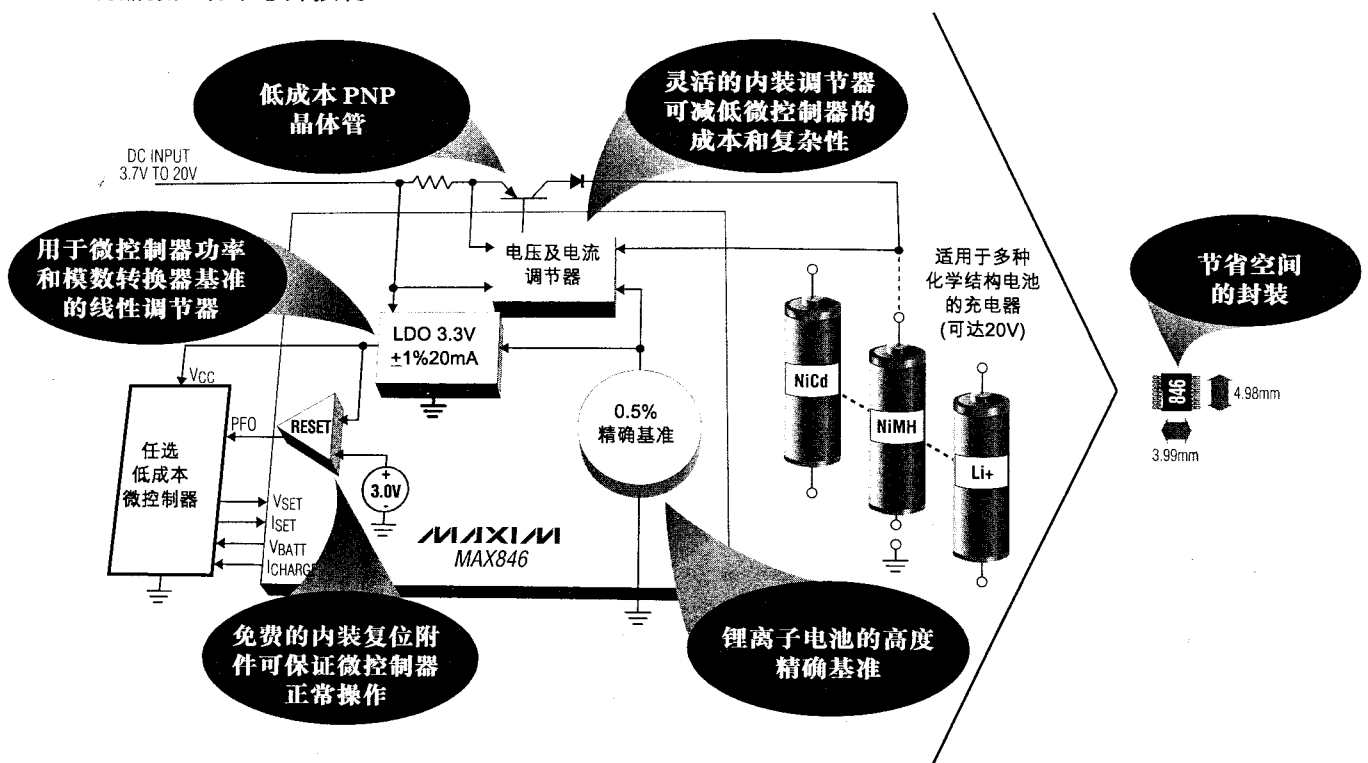

免费提供电源设计指南
包括：数据表和免费样品卡。

欢迎索取设计指南，请在《免费查询表》相应的查询号上划圈，或与您所在的当地代理商联系。

MAXIM

<http://www.maxim-ic.com>



P&S (Wuhan) (86) 27-7885651, FAX (86) 27-7802985

China: P & S, (Wuhan) (86) 27 7885651, FAX (86) 27 7802985, (Beijing) (86) 1 2536518, (Shanghai) (86) 21 63732879, (Shenzhen) (86) 755 3223285, (Chengdu) (86) 28 5211423; India: Sritech Information Technology Pvt Ltd., (Bangalore) 80-640661,640386, FAX 80-6633508; Hong Kong: Maxim Integrated Products, Inc: 852-2376-3000, FAX 852-2376-3001; Korea: Maxim Integrated Products (Korea) 82-2-508-1170, FAX 82-2-508-1171; Taiwan: Maxim Integrated Products (Taiwan) 886-2-558-6801, FAX 886-2-555-6348, Solomon Technology Corp., (02) 788-8989, FAX (02) 788-8029; Singapore: Maxim Singapore, (Singapore) 65-841-7117, FAX 65-841-7227, Electronic Resources Limited, (65) 298-0888, FAX (65) 298-1111; Malaysia: Electronic Resources (Malaysia) Sdn. Bhd., (Kuala Lumpur) (60) 3-7038498, FAX (60) 3-7038526, (Penang) (60) 4-6562895, FAX (60) 4-6588872; Thailand: Electronic Resources (Thailand) Co. Ltd., (Bangkok) (662) 3701280-90, FAX (662) 3701277-8; Japan: Maxim Japan Co., Ltd., (03) 3232-6149, FAX (03) 3232-6149; Internix, (03) 3369-1105, FAX (03) 3363-8486; Easton (03) 3279-1920, FAX (03) 3279-1935; Sil Walker (03) 3341-3651, FAX (03) 3341-3974; Microtek (03) 5300-5535, FAX (03) 5300-5515; Australia: Veltek Pty. Ltd., (Victoria) (03) 9574 9300, FAX (03) 9574 9773.

MAXIM is a registered trademark of Maxim Integrated Products. © 1996 Maxim Integrated Products.

咨询卡编号 0092

±0.75% 精密锂离子电池充电器 可提供 4A 充电电流而不会自热

MAX745 可提供对锂离子电池组充电时必备的所有功能。它采用效率高达 90% 的开关方式设计,能提供高达 4A 的可调充电电流,而不会产生过大的热量。在电池两端,精密输出电压总误差小于 0.75%,使蓄电量达到最大程度。独立的电压和电流控制回路协同工作,可在电流调节和电压调节之间平稳过渡。

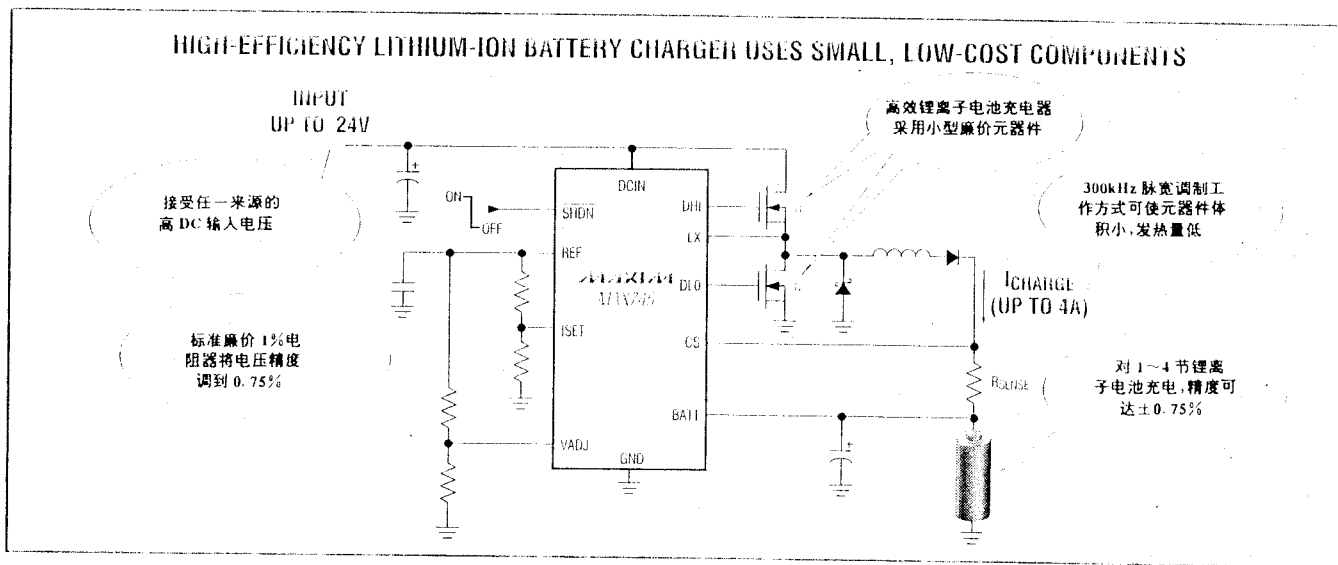

MAX745 采用 300kHz 脉宽调制开关方式控制器,能以小型低噪声外部元器件提供精密高效电压和电流调节。

根据您的应用选择理想的电池充电器

器件	化学组成				说明
	Li+	NiCd	NiMH	多种	
MAX745	✓				开关方式,独立系统
MAX846A	✓	✓	✓	✓	线性方式,独立系统或微控制器可调
MAX1647/1648	✓	✓	✓	✓	开关方式,带 SMBus™ 接口
MAX2003A		✓	✓		开关方式,独立系统
MAX712/713		✓	✓		线性方式,独立系统

SMBus 是 Intel 公司的注册商标

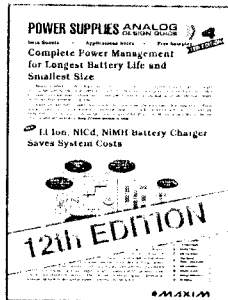

免费赠送无线设计指南——24 小时内发送!

包括:技术条件和免费样品插卡

要获取设计指南,请在读者反馈号上划圈或与您当地经销商联系



<http://www.maxim-ic.com>

P&S 武汉力源电子股份有限公司 (MAXIM 中国总代理)



地址:武汉市武昌单刀路 15 号 通信:武汉市 70020 信箱 邮编:430070 电话:(027)7493500~7493506 传真:7491166
 北京办事处:海淀区海淀路 19-1 号中成大厦 1104 室 邮编:100080 电话:(010)62536518 深圳办事处:福田爱华路北口长城俱乐部一楼 102 室
 邮编:518031 电话:(0755)3353183 上海办事处:长乐路 1219 号长鑫大厦 605 室 邮编:200031 电话:(021)64714208 成都办事处:一环
 路南一段 53 号金城大厦 504 室 邮编:610061 电话:(028)5563631 南京办事处:中山南路 289 号都市宾馆 410 室 邮编:210005 电话:(025)
 4526775 武汉办事处:武昌珞瑜路 70 号 邮编:430070 电话:(027)7862631 香港办事处:九龙佐敦道吴淞街 122-124 号利际商业大楼 6 楼 B
 座 电话:(852)23142786

查询号:6

MAXIM is a registered trademark of Maxim Integrated Products. © 1997 Maxim Integrated Products.



Cost-Saving Multichemistry Battery-Charger System

MAX846A

General Description

The MAX846A is a cost-saving multichemistry battery-charger system that comes in a space-saving 16-pin QSOP. This integrated system allows different battery chemistries (Li-Ion, NiMH or NiCd cells) to be charged using one circuit.

In its simplest application, the MAX846A is a stand-alone, current-limited float voltage source that charges Li-Ion cells. It can also be paired up with a low-cost microcontroller (μC) to build a universal charger capable of charging Li-Ion, NiMH, and NiCd cells.

An internal 0.5%-accurate reference allows safe charging of Li-Ion cells that require tight voltage accuracy. The voltage- and current-regulation loops used to control a low-cost external PNP transistor (or P-channel MOSFET) are independent of each other, allowing more flexibility in the charging algorithms.

The MAX846A has a built-in 1%, 3.3V, 20mA linear regulator capable of powering the μC and providing a reference for the μC 's analog-to-digital converters. An on-board reset notifies the controller upon any unexpected loss of power. The μC can be inexpensive, since its only functions are to monitor the voltage and current and to change the charging algorithms.

Applications

- Li-Ion Battery Packs
- Desktop Cradle Chargers
- Li-Ion/NiMH/NiCd Multichemistry Battery Chargers
- Cellular Phones
- Notebook Computers
- Hand-Held Instruments

Pin Configuration

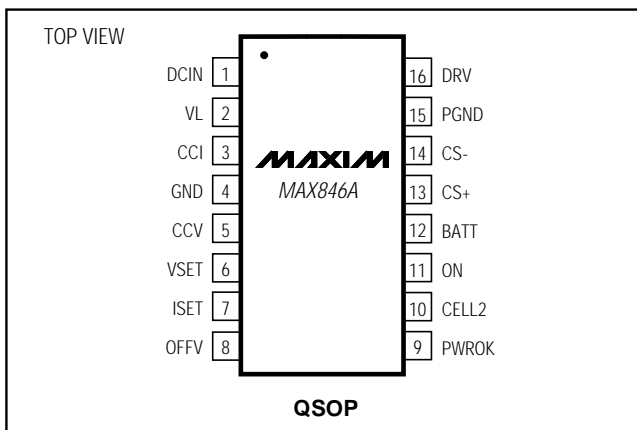

Features

- ◆ **Multichemistry Charger System (Li-Ion, NiMH, NiCd)**
- ◆ **Independent Voltage and Current Loops**
- ◆ **$\pm 0.5\%$ Internal Reference for Li-Ion Cells**
- ◆ **Lowers Cost:**
 - Stands Alone or Uses Low-Cost μC
 - Built-In 1% Linear Regulator Powers μC
 - Linear Regulator Provides Reference to μC ADCs
 - Built-In μC Reset
 - Controls Low-Cost External PNP Transistor or P-Channel MOSFET
- ◆ **Space-Saving 16-Pin QSOP**
- ◆ **Charging-Current-Monitor Output**
- ◆ **$< 1\mu\text{A}$ Battery Drain when Off**

Ordering Information

PART	TEMP. RANGE	PIN-PACKAGE
MAX846AC/D	0°C to +70°C	Dice*
MAX846AEEE	-40°C to +85°C	16 QSOP

*Dice are tested at $T_A = +25^\circ\text{C}$ only. Contact factory for details.

Typical Operating Circuit

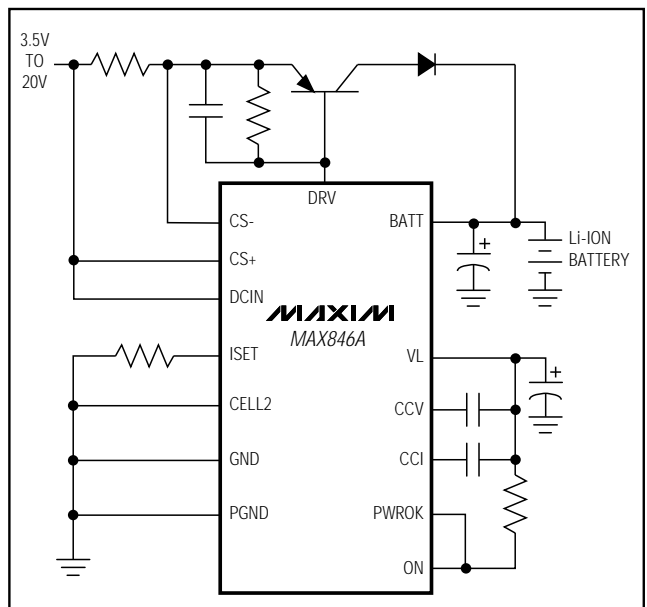

Cost-Saving Multichemistry Battery-Charger System

MAX846A

ABSOLUTE MAXIMUM RATINGS

DCIN, DRV, CS+, CS-, BATT to GND.....	-0.3V, +21V
PGND to GND.....	±0.3V
VL to GND.....	-0.3V, 7V
IPWROK.....	10mA
PWROK, ISET, CCI, CCV, OFFV, VSET, CELL2, ON to GND.....	-0.3V, VL + 0.3V
CS+ to CS-.....	±0.3V
VL Short to GND.....	Continuous
IDRV.....	100mA

Continuous Power Dissipation (TA = +70°C)	
QSOP (derate 8.3mW/°C above +70°C).....	667mW
Operating Temperature Range	
MAX846AEEE.....	-40°C to +85°C
Junction Temperature.....	+150°C
Storage Temperature Range.....	-65°C to +160°C
Lead Temperature (soldering, 10sec).....	+300°C

Stresses beyond those listed under "Absolute Maximum Ratings" may cause permanent damage to the device. These are stress ratings only, and functional operation of the device at these or any other conditions beyond those indicated in the operational sections of the specifications is not implied. Exposure to absolute maximum rating conditions for extended periods may affect device reliability.

ELECTRICAL CHARACTERISTICS

(V_{DCIN} = 10V, ON = VL, I_{VL} = I_{VSET} = 0mA, V_{CS-} = V_{CS+} = 10V, V_{BATT} = 4.5V, V_{OFFV} = V_{CELL2} = 0V, T_A = 0°C to +85°C, unless otherwise noted. Typical values are at T_A = +25°C.)

PARAMETER	CONDITIONS	MIN	TYP	MAX	UNITS
VL REGULATOR					
DCIN Supply Current	V _{DCIN} = 20V, I _{DRV} = I _{VL} = 0mA			5	mA
Operating Range		3.7		20.0	V
Output Voltage	0mA < I _{VL} < 20mA, 3.7V < V _{DCIN} < 20V	3.267	3.305	3.333	V
Short-Circuit Current Limit	VL = GND		50		mA
PWROK Trip Level	Rising VL edge, 2% hysteresis	2.9	3.0	3.1	V
VL Undervoltage-Lockout Level		2.5		2.9	V
REFERENCE					
Output Voltage	Measured at VSET, I _{VSET} = 0mA, V _{ON} = 0V	-0.5%	1.650	+0.5%	V
Output Resistance		-2%	20	+2%	kΩ
CURRENT-SENSE AMPLIFIER					
Transconductance	V _{ISET} = 1.7V, V _{CS+} - V _{CS-} = 165mV	0.95	1	1.05	mA/V
Output Offset Current	V _{CS+} = 4V			3	μA
Input Common-Mode Range	Measured at V _{CS-} , V _{CS+} - V _{CS-} = 165mV	2.1		20.0	V
Maximum Differential Input Voltage	V _{CS-} = V _{ISET} = 2.1V, CSA transconductance >0.9mA/V	225			mV
CS- Lockout Voltage	When V _{CS-} is less than this voltage, DRV is disabled.	1.9		2.1	V
CS+, CS- Input Current	V _{CS+} = 20V, V _{CS+} - V _{CS-} = 165mV			250	μA
CS+, CS- Off Input Current	DCIN = VL = ON = GND		0.01	10	μA

Cost-Saving Multichemistry Battery-Charger System

MAX846A

ELECTRICAL CHARACTERISTICS (continued)

($V_{DCIN} = 10V$, $ON = VL$, $I_{VL} = I_{VSET} = 0mA$, $V_{CS-} = V_{CS+} = 10V$, $V_{BATT} = 4.5V$, $V_{OFFV} = V_{CELL2} = 0V$, $T_A = 0^\circ C$ to $+85^\circ C$, unless otherwise noted. Typical values are at $T_A = +25^\circ C$.)

PARAMETER	CONDITIONS	MIN	TYP	MAX	UNITS
VOLTAGE LOOP					
Voltage-Loop Set Point	$V_{VSET} = 1.650V$, $V_{CELL2} = 0V$, $I_{DRV} = 1mA$, $V_{DRV} = 10V$	-0.25%	4.2	+0.25%	V
	$V_{VSET} = 1.650V$, $V_{CELL2} = VL$, $I_{DRV} = 1mA$, $V_{DRV} = 10V$	-0.25%	8.4	+0.25%	
VSET Common-Mode Input Range		1.25		2.0	V
CCV Output Impedance			150		$k\Omega$
Voltage-Loop Load Regulation	$1mA < I_{DRV} < 5mA$		0.05		%
BATT Input Current	$V_{BATT} = 10V$, $CELL2 = GND$ or VL			225	μA
BATT Off Input Current	$V_{BATT} = 10V$, $ON = GND$, $CELL2 = GND$ or VL		0.01	1	μA
CURRENT LOOP					
Current-Loop Set Point	$I_{DRV} = 5mA$, $V_{DRV} = 10V$	1.634	1.650	1.666	V
CA Voltage Gain			5		V/V
CCI Output Impedance			50		$k\Omega$
Overcurrent Trip Level	When V_{ISET} exceeds this voltage, DRV current is disabled.	1.90		2.1	V
DRIVER					
DRV Sink Current	$V_{DRV} = 3V$	20			mA
DRV Off Current	$V_{DRV} = 20V$, $V_{ON} = 0V$		0.1	100	μA
LOGIC INPUTS AND OUTPUTS					
Input High Level	CELL2, ON, OFFV	2.4		VL	V
Input Low Level	CELL2, ON, OFFV	0		0.8	V
Input Current	CELL2, ON, OFFV		0.01	1	μA
PWROK Output Low Level	$I_{PWROK} = 1mA$, $V_{DCIN} = V_{VL} = 2.5V$			0.4	V
PWROK Output High Leakage	$V_{PWROK} = 3.3V$		0.01	1	μA

Cost-Saving Multichemistry Battery-Charger System

MAX846A

ELECTRICAL CHARACTERISTICS (Note 1)

($V_{DCIN} = 10V$, $ON = VL$, $I_{VL} = I_{VSET} = 0mA$, $V_{CS-} = V_{CS+} = 10V$, $V_{BATT} = 4.5V$, $V_{OFFV} = V_{CELL2} = 0V$, $T_A = -40^{\circ}C$ to $+85^{\circ}C$, unless otherwise noted.)

PARAMETER	CONDITIONS	MIN	TYP	MAX	UNITS
VL REGULATOR					
DCIN Supply Current	$V_{DCIN} = 20V$, $I_{DRV} = I_{VL} = 0mA$			5	mA
Output Voltage	$0mA < I_{VL} < 20mA$, $3.7V < V_{DCIN} < 20V$	3.259		3.341	V
PWROK Trip Level	Rising VL edge, 2% hysteresis	2.9		3.1	V
VL Undervoltage-Lockout Level		2.5		3.0	V
REFERENCE					
Output Voltage	Measured at V_{SET} , $I_{VSET} = 0mA$, $V_{ON} = 0V$	-0.7%	1.650	+0.7%	V
Output Resistance		-2%	20	+2%	k Ω
CURRENT-SENSE AMPLIFIER					
Transconductance	$V_{ISET} = 1.7V$, $V_{CS+} - V_{CS-} = 165mV$	0.93		1.07	mA/V
Output Offset Current	$V_{CS+} = 4V$			5	μA
CS+, CS- Off Input Current	$V_{ON} = 0V$, $V_{CS+} = V_{CS-} = 10V$			10	μA
VOLTAGE LOOP					
Voltage-Loop Set Point	$V_{VSET} = 1.650V$, $V_{CELL2} = 0V$, $I_{DRV} = 1mA$, $V_{DRV} = 10V$	-0.35%	4.2	+0.35%	V
	$V_{VSET} = 1.650V$, $V_{CELL2} = VL$, $I_{DRV} = 1mA$, $V_{DRV} = 10V$	-0.35%	8.4	+0.35%	
BATT Off Input Current	$V_{BATT} = 10V$, $ON = GND$, $CELL2 = GND$ or VL			1	μA
CURRENT LOOP					
Current-Loop Set Point	$I_{DRV} = 5mA$, $V_{DRV} = 10V$	1.625		1.675	V
Overcurrent Trip Level	When V_{ISET} exceeds this voltage, DRV current is disabled.	1.86		2.14	V
DRIVER					
DRV Sink Current	$V_{DRV} = 3V$	20			mA
DRV Off Current	$V_{DRV} = 20V$, $ON = GND$			100	μA

Note 1: Specifications to $-40^{\circ}C$ are guaranteed by design and not production tested.

Cost-Saving Multichemistry Battery-Charger System

Typical Operating Characteristics

($T_A = +25^\circ\text{C}$, unless otherwise noted.)

MAX846A

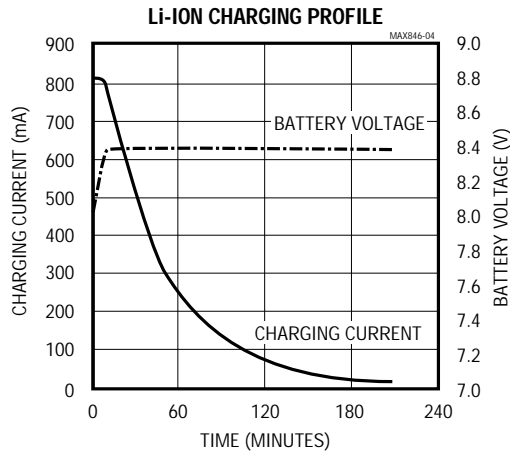
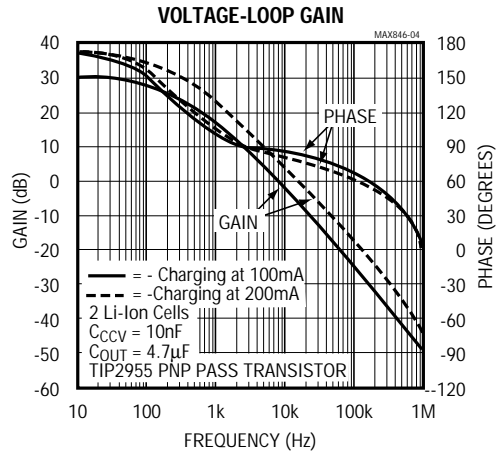
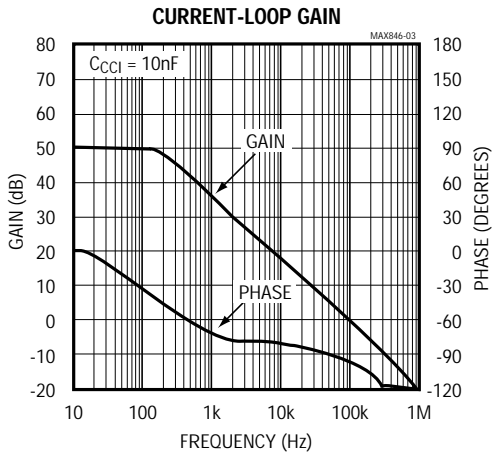
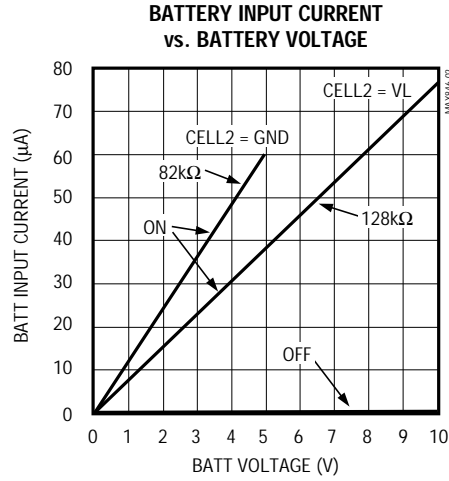
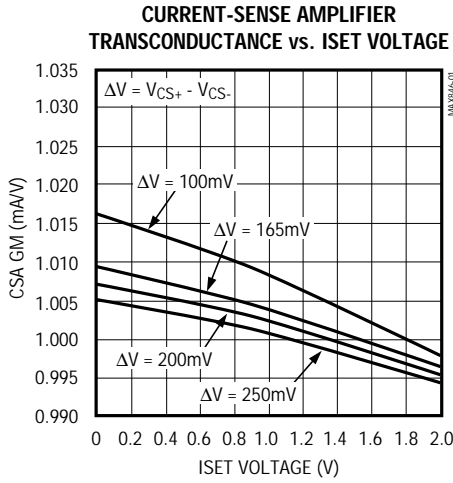

Cost-Saving Multichemistry Battery-Charger System

MAX846A

Pin Description

PIN	NAME	FUNCTION
1	DCIN	Supply Input from External DC Source. $3.7V \leq V_{DCIN} \leq 20V$.
2	VL	3.3V, 20mA, 1% Linear-Regulator Output. VL powers the system μC and other components. Bypass to GND with a 4.7 μF tantalum or ceramic capacitor.
3	CCI	Current-Regulation-Loop Compensation Pin. Connect a compensation capacitor (typically 10nF) from CCI to VL.
4	GND	Ground
5	CCV	Voltage-Regulation-Loop Compensation Pin. Connect a compensation capacitor (typically 10nF) from CCV to VL.
6	VSET	Float-Voltage Reference-Adjust Input. Leave VSET open for a 4.2V default. See the <i>Applications Information</i> section for adjustment information.
7	ISET	Current-Set Input/Current-Monitor Output. ISET sets the current-regulation point. Connect a resistor from ISET to GND to monitor the charging current. ISET voltage is regulated at 1.65V by the current-regulation loop. To adjust the current-regulation point, either modify the resistance from ISET to ground or connect a fixed resistor and adjust the voltage on the other side of the resistor (Figure 5). The transconductance of the current-sense amplifier is 1mA/V.
8	OFFV	Logic Input that disables the voltage-regulation loop. Set OFFV high for NiCd or NiMH batteries.
9	PWROK	Open-Drain, Power-Good Output to μC . PWROK is low when VL is less than 3V. The reset timeout period can be set externally using an RC circuit (Figure 3).
10	CELL2	Digital Input. CELL2 programs the number of Li-Ion cells to be charged. A high level equals two cells; a low level equals one cell.
11	ON	Charger ON/OFF Input. When low, the driver section is turned off and $I_{BATT} < 1\mu A$. The VL regulator is always active.
12	BATT	Battery Input. Connect BATT to positive battery terminal.
13	CS+	Current-Sense Amplifier High-Side Input. Connect CS+ to the sense resistor's power-source side. The sense resistor may be placed on either side of the pass transistor.
14	CS-	Current-Sense Amplifier Low-Side Input. Connect CS- to the sense resistor's battery side.
15	PGND	Power Ground
16	DRV	External Pass Transistor (P-channel MOSFET or PNP) Base/Gate Drive Output. DRV sinks current only.

Detailed Description

The MAX846A battery-charging controller combines three functional blocks: a 3.3V precision, low-dropout linear regulator (LDO), a precision voltage reference, and a voltage/current regulator (Figure 1).

Linear Regulator

The LDO regulator output voltage (VL) is two times the internal reference voltage; therefore, the reference and LDO track. VL delivers up to 20mA to an external load and is short-circuit protected. The power-good output (PWROK) provides microcontroller (μC) reset and charge-current inhibition.

Voltage Reference

The precision internal reference provides a voltage to accurately set the float voltage for lithium-ion (Li-Ion) battery charging. The reference output connects in series with an internal, 2%-accurate, 20k Ω resistor. This allows the float voltage to be adjusted using one external 1% resistor (R_{VSET}) to form a voltage divider (Figure 4). The float-voltage accuracy is important for battery life and to ensure full capacity in Li-Ion batteries. Table 1 shows the accuracies attainable using the MAX846A.

Cost-Saving Multichemistry Battery-Charger System

Voltage/Current Regulator

The voltage/current regulator consists of a precision attenuator, voltage loop, current-sense amplifier, and current loop. The attenuator can be pin programmed to set the regulation voltage for one or two Li-Ion cells (4.2V and 8.4V, respectively). The current-sense amplifier is configured to sense the battery current on the high side. It is, in essence, a transconductance amplifier converting the voltage across an external sense resistor (R_{CS}) to a current, and applying this current to an external load resistor (R_{ISET}). Set the charge current by selecting R_{CS} and R_{ISET} . The charge current can also be adjusted by varying the voltage at the low side of R_{ISET} or by summing/subtracting current from the ISET node (Figure 5). The voltage and current loops are individually compensated using external capacitors at CCV and CCI, respectively. The outputs of these two loops are OR'ed together and drive an open-drain, internal N-channel MOSFET transistor sinking current to ground. An external P-channel MOSFET or PNP transistor pass element completes the loop.

Stability

The *Typical Operating Characteristics* show the loop gains for the current loop and voltage loop. The dominant pole for each loop is set by the compensation capacitor connected to each capacitive compensation pin (CCI, CCV). The DC loop gains are about 50dB for the current loop and about 33dB for the voltage loop, for a battery impedance of 250m Ω .

The CCI output impedance (50k Ω) and the CCI capacitor determine the current-loop dominant pole. In Figure 2, the recommended C_{CCV} is 10nF, which places a dominant pole at 300Hz. There is a high-frequency pole, due to the external PNP, at approximately f_T/β . This pole frequency (on the order of a few hundred kilohertz) will vary with the type of PNP used. Connect a 10nF capacitor between the base and emitter of the

PNP to prevent self-oscillation (due to the high-impedance base drive).

Similarly, the CCV output impedance (150k Ω) and the CCV capacitor set the voltage-loop dominant pole. In Figure 2, the compensation capacitance is 10nF, which places a dominant pole at 200Hz.

The battery impedance directly affects the voltage-loop DC and high-frequency gain. At DC, the loop gain is proportional to the battery resistance. At higher frequencies, the AC impedance of the battery and its connections introduces an additional high-frequency zero. A 4.7 μ F output capacitor in parallel with the battery, mounted close to BATT, minimizes the impact of this impedance. The effect of the battery impedance on DC gain is noticeable in the Voltage-Loop-Gain graph (see *Typical Operating Characteristics*). The solid line represents voltage-loop gain versus frequency for a fully charged battery, when the battery energy level is high and the ESR is low. The charging current is 100mA. The dashed line shows the loop gain with a 200mA charging current, a lower amount of stored energy in the battery, and a higher battery ESR.

Applications Information

Stand-Alone Li-Ion Charger

Figure 2 shows the stand-alone configuration of the MAX846A. Select the external components and pin configurations as follows:

- Program the number of cells: Connect CELL2 to GND for one-cell operation, or to VL for two-cell operation.
- Program the float voltage: Connect a 1% resistor from VSET to GND to adjust the float voltage down, or to VL to adjust it up. If VSET is unconnected, the float voltage will be 4.2V per cell. Let the desired float voltage per cell be V_F , and calculate the resistor value as follows:

Table 1. Float-Voltage Accuracy

ERROR SOURCE	ERROR
Internal-reference accuracy	±0.5%
VSET error due to external divider. Calculated from a 2% internal 20k Ω resistor tolerance and a 1% external R_{VSET} resistor tolerance. The total error is 3% x (adjustment). Assume max adjustment range of 5%.	±0.15%
VSET amplifier and divider accuracy	±0.25%
TOTAL	±0.9%

Cost-Saving Multichemistry Battery-Charger System

MAX846A

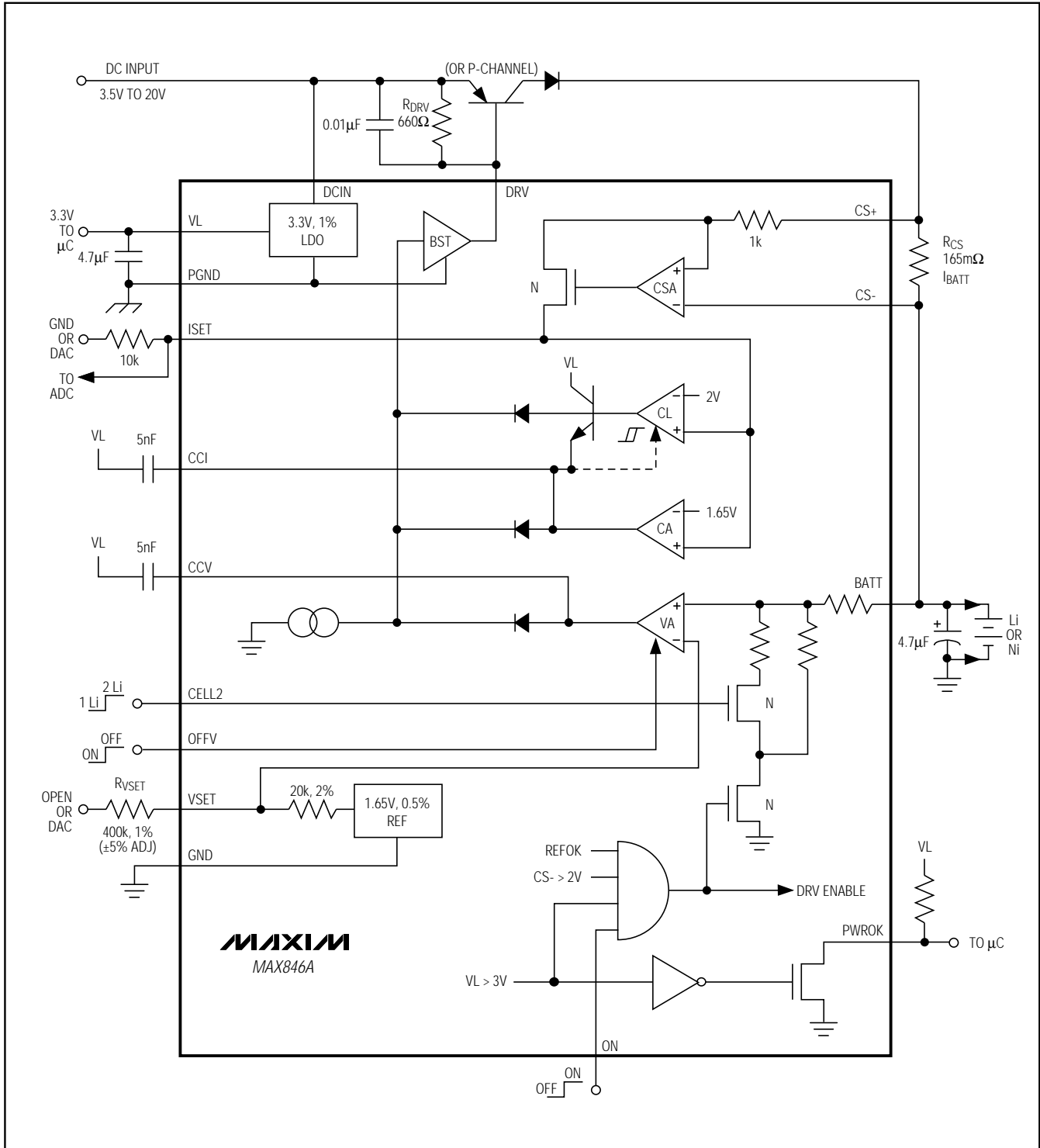

Figure 1. Functional Diagram

Cost-Saving Multichemistry Battery-Charger System

MAX846A

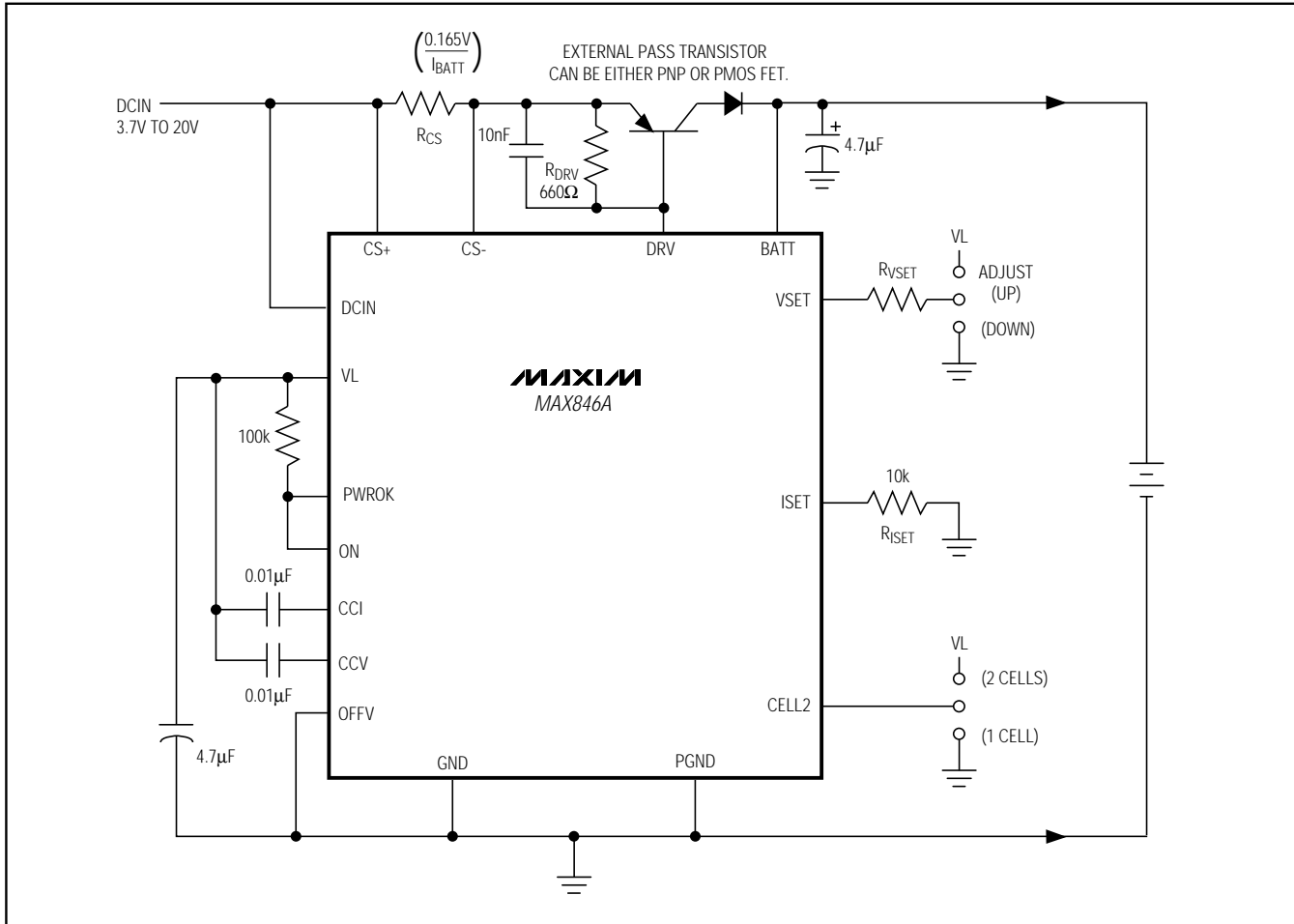

Figure 2. Stand-Alone Li-Ion Charger

$$R_{VSET} = 20k\Omega \left(\frac{4.2}{1.65} \frac{V_X - V_F}{V_F - 4.2} \right)$$

where V_X is either GND or VL, and V_F is the per-cell float voltage. In the circuit of Figure 1, R_{VSET} is 400k Ω . R_{VSET} and the internal 20k Ω resistor form a divider, resulting in an adjustment range of approximately $\pm 5\%$.

The current-regulation loop attempts to maintain the voltage on ISET at 1.65V. Selecting resistor R_{ISET} determines the reflected voltage required at the current-sense amplifier input.

- Calculate R_{CS} and R_{ISET} as follows:

$$R_{CS} = V_{CS} / I_{BATT}$$

$$R_{ISET} \text{ (in } k\Omega) = 1.65V / V_{CS}$$

where the recommended value for V_{CS} is 165mV.

- Connect ON to PWROK to prevent the charge current from turning on until the voltages have settled.

Minimize power dissipation in the external pass transistor. Power dissipation can be controlled by setting the DCIN input supply as low as possible, or by making V_{DCIN} track the battery voltage.

Microprocessor-Controlled Multichemistry Operation

The MAX846A is highly adjustable, allowing for simple interfacing with a low-cost μC to charge Ni-based and Li-Ion batteries using one application circuit (Figure 3).

Cost-Saving Multichemistry Battery-Charger System

MAX846A

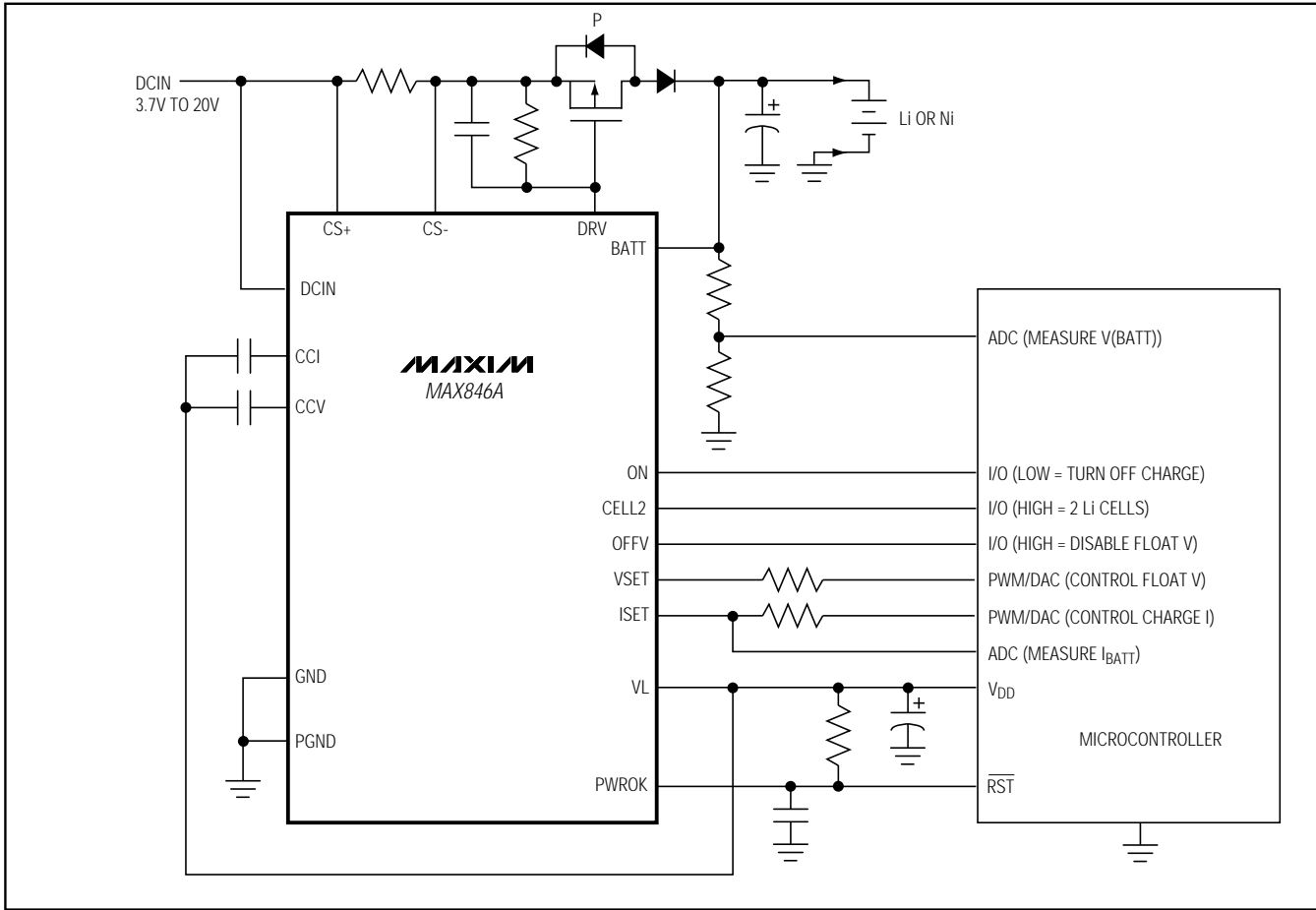

Figure 3. Desktop Multichemistry Charger Concept

Component selection is similar to that of stand-alone operation. By using DACs or μC PWM outputs, the float voltage and charging current can be adjusted by the μC . When a Ni-based battery is being charged, disable the float-voltage regulation using the OFFV input. The μC can also monitor the charge current through the battery by reading the ISET output's voltage using its ADC. Similarly, the battery voltage can be measured using a voltage divider from the battery.

Note that the μC only needs to configure the system for correct voltage and current levels for the battery being charged, and for Ni-based batteries to detect end-of-charge and adjust the current level to trickle. The controller is not burdened with the regulation task.

Float-voltage accuracy is important for battery life and for reaching full capacity for Li-Ion batteries. Table 1 shows the accuracy attainable using the MAX846A.

For best float-voltage accuracy, set the DRV current to 1mA ($R_{\text{DRV}} = 660\Omega$ for a PNP pass transistor).

High-Power Multichemistry Offline Charger

The circuit in Figure 6 minimizes power dissipation in the pass transistor by providing optical feedback to the input power source. The offline AC/DC converter maintains 1.2V across the PNP. This allows much higher charging currents than can be used with conventional power sources.

Cost-Saving Multichemistry Battery-Charger System

MAX846A

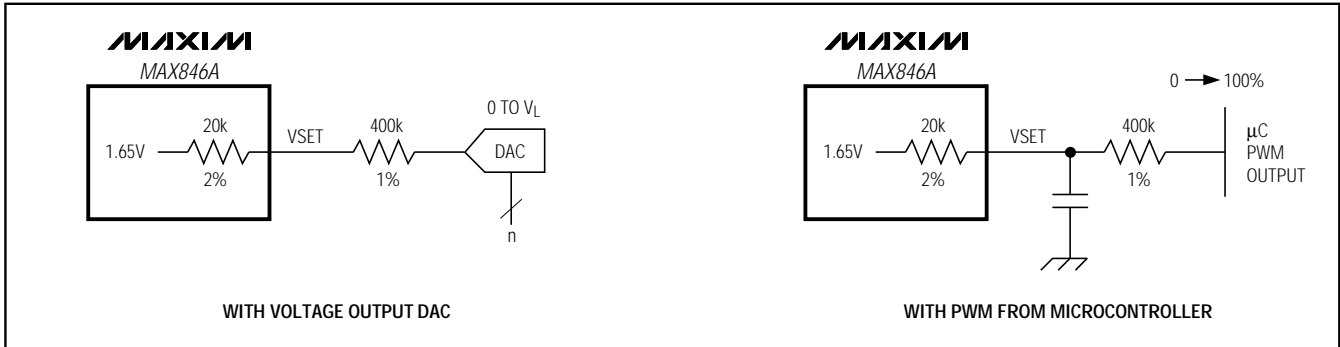

Figure 4. VSET Adjustment Methods

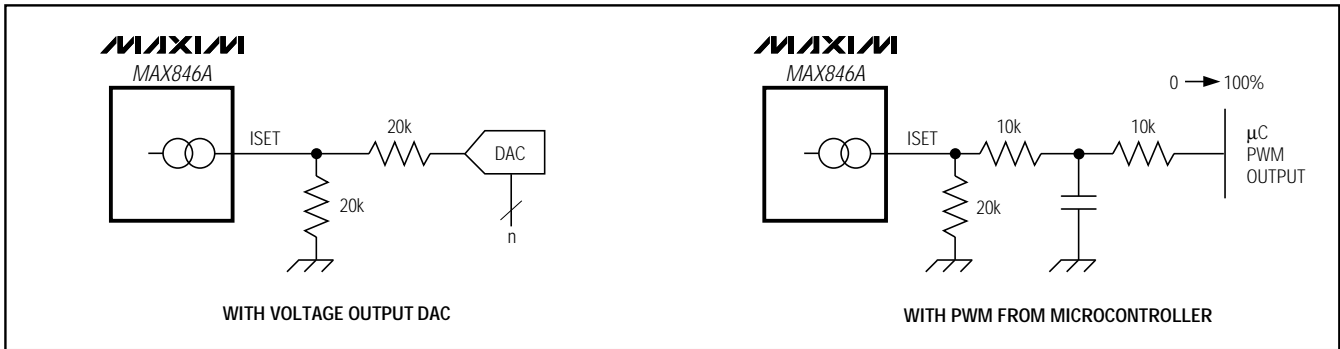

Figure 5. ISET Adjustment Methods

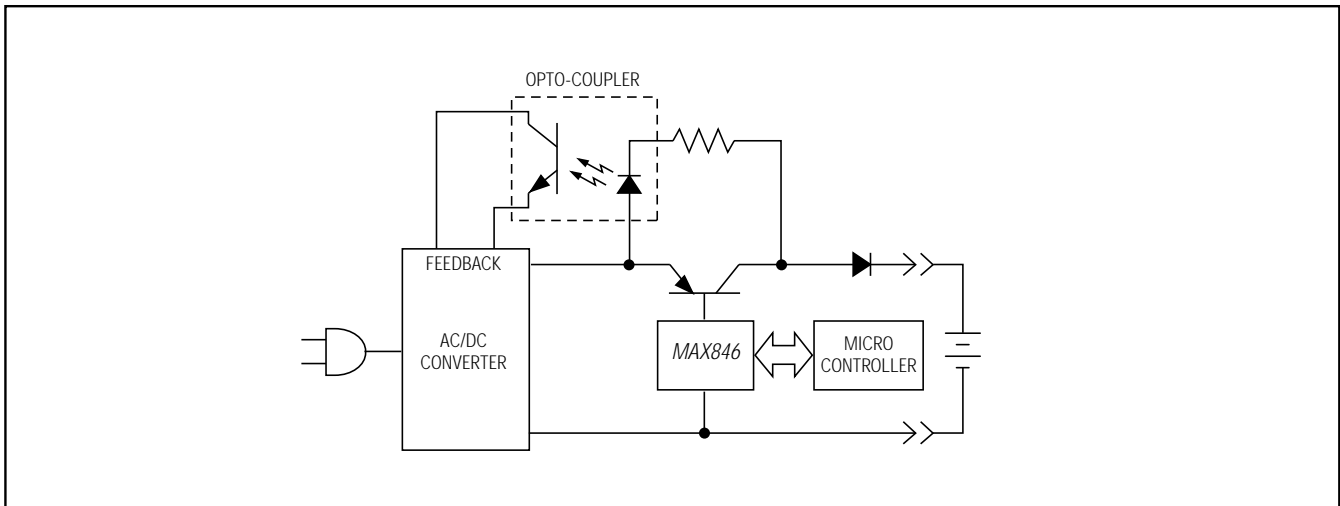
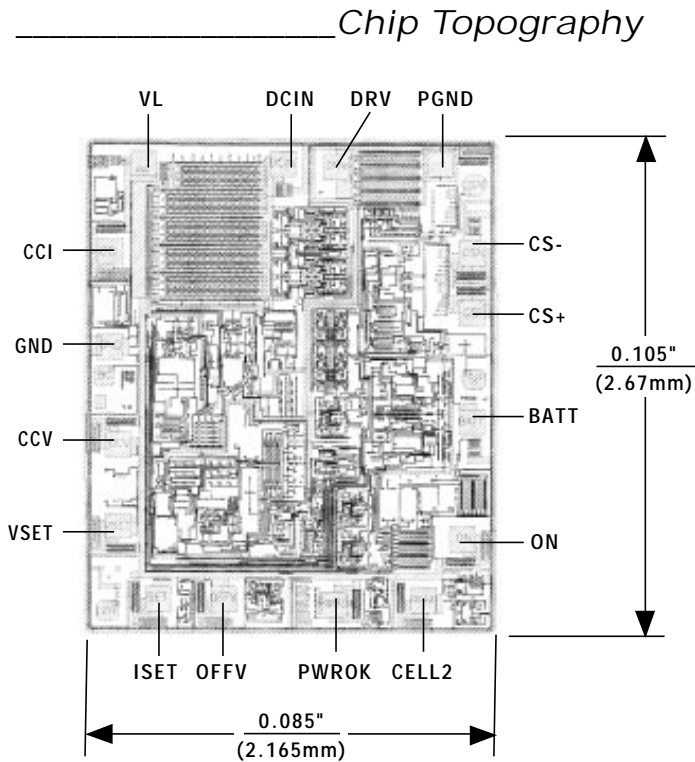

Figure 6. Low-Cost Desktop Multichemistry Charger Concept

Cost-Saving Multichemistry Battery-Charger System

MAX846A



SUBSTRATE CONNECTED TO GND
TRANSISTOR COUNT: 349

Maxim cannot assume responsibility for use of any circuitry other than circuitry entirely embodied in a Maxim product. No circuit patent licenses are implied. Maxim reserves the right to change the circuitry and specifications without notice at any time.

12 Maxim Integrated Products, 120 San Gabriel Drive, Sunnyvale, CA 94086 (408) 737-7600

© 1996 Maxim Integrated Products

Printed USA

MAXIM is a registered trademark of Maxim Integrated Products.



MAX846A Evaluation Kit

Evaluates: MAX846A

General Description

The MAX846A evaluation kit (EV kit) is a stand-alone charger for lithium-ion (Li-Ion) batteries. The charging regulator consists of voltage and current loops driving an external, low-cost, PNP pass transistor. In voltage-regulation mode, a current-to-voltage converter supplies a voltage proportional to the current flowing through the Li-Ion battery. The float voltage and charging current can be programmed with just two external resistors. The MAX846A EV kit is shipped configured for charging two Li-Ion cells at 800mA from a 10V power source.

The MAX846A EV kit is a fully assembled and tested surface-mount printed circuit board.

Features

- ◆ **0.5% Internal Reference for Li-Ion Charging**
- ◆ **Regulates Voltage and Current into Battery**
- ◆ **Selectable 1 or 2-Cell Li-Ion Charge**
- ◆ **1%, 3.3V, On-Chip, Low-Dropout Linear Regulator**
- ◆ **1µA Max Battery Drain when Off**
- ◆ **Power-Good Function**
- ◆ **Surface-Mount Components**
- ◆ **Fully Assembled and Tested**

Component List

DESIGNATION	QTY	DESCRIPTION
C1	1	22µF, 35V electrolytic capacitor Sanyo 35CV22GX
C2	1	0.1µF ceramic capacitors
C3	1	4.7µF, 16V tantalum capacitor Sprague 595D475X0016A2B
C4, C5, C6	3	0.01µF ceramic capacitors
C7	1	4.7µF, 35V electrolytic capacitor Sanyo 35CV4.7GX
D1	1	1A, 100V fast-recovery diode Nihon EC10DS1
Q1	1	PNP power transistor (SOT-223) Zetex FZT749
R1, R6	2	0.400Ω, 1%, 1/2W resistors Dale WSL-2010-R400-F or IRC LR2010-01-R400-F
R2	1	680Ω, 5% resistor
R3	1	10kΩ, 5% resistor
R4	1	100kΩ, 5% resistor
R5	1	825kΩ, 1% resistor
U1	1	Maxim MAX846AEEE
J1	1	PC mount jack RDI Electronics DJ-005
J2	1	2-pin term connector
JU1–JU4	4	3-pin headers
JU5	1	2-pin header
None	0	6.0V at 800mA AC adapter (1 cell) James Electronics 14311 (not supplied) 9V at 830mA AC adapter (2 cells) James Electronics 14323 (not supplied)
None	4	Shunts
None	1	MAX846A PC board

Ordering Information

PART	TEMP. RANGE	BOARD TYPE
MAX846EVKIT	0°C to +70°C	Surface Mount

Component Suppliers

SUPPLIER	PHONE	FAX
AVX	(803) 946-0690 (800) 282-4975	(803) 626-3123
Dale-Vishay	(402) 564-3131	(402) 563-6418
IRC	(512) 992-7900	(512) 992-3377
James Electronics	(312) 463-6500	(312) 463-1504
Motorola	(602) 303-5454	(602) 994-6430
Nichicon	(847) 843-7500	(847) 843-2798
Nihon	(805) 867-2555	(805) 867-2698
Sanyo	(619) 661-6835	(619) 661-1055
Sprague	(603) 224-1961	(603) 224-1430
RDI Electronics	(914) 773-1000	(914) 773-1111
Vishay/Vitramon	(203) 268-6261	(203) 452-5670
Zetex	(516) 543-7100	(516) 864-7630



MAX846A Evaluation Kit

Evaluates: MAX846A

Quick Start

The MAX846A Evaluation Kit (EV kit) is fully assembled and tested. Follow these steps to verify board operation. **Do not turn on the power supply until all connections are completed.**

- 1) Place the shunt across JU2's pins to set the number of cells being charged in the battery pack. The EV kit is shipped configured for two lithium-ion (Li-Ion) cells (shunt across pins 1 and 2).
- 2) Set the charging current with R1 and R6. The charge current is preset for 800mA ($R1 = R6 = 400m\Omega$). For 400mA charge current, remove R6. Consult the battery manufacturer for recommended charging currents.
- 3) Connect the battery pack to the two-pin power connector J2. Observe the polarity markings.
- 4) Connect the external supply voltage to the VIN and GND pads. For charging one cell, use a 6V supply; for 2 cells, use a 10V supply.
- 5) Turn on the power supply to the board and confirm the voltage across the battery using a voltmeter.

Detailed Description

The MAX846A EV kit is a stand-alone charger for Li-Ion batteries. The charging regulator consists of voltage and current loops driving an external, low-cost, PNP pass transistor (Q1). The MAX846A requires an input 1V greater than the maximum charging voltage.

Higher input voltages and charging currents can be used as long as Q1's power dissipation does not exceed 2W. (At 2W, Q1 may exceed +70°C). For higher power dissipation and cooler operation, replace Q1 with a TO220 transistor (TIP42) and heatsink in holes provided.

Selecting the Number of Li-Ion Cells

Jumper JU2 selects the number of battery-pack cells. Place the shunt across JU2's pins to select the desired number of cells (Table 1). The MAX846A EV kit is shipped configured for two cells.

Table 1. Jumper JU2 Functions

SHUNT LOCATION	CELL2 PIN	NUMBER OF CELLS
1 & 2	Connected to VL	2
2 & 3	Connected to GND	1

Jumper Selection

The three-pin header JU1 selects shutdown mode. Table 2 lists the selectable jumper options.

Table 2. Jumper JU1 Functions

SHUNT LOCATION	ON PIN	MAX846A OUTPUT
1 & 2	Connected to PWROK	Enabled
2 & 3	Connected to GND	Shutdown mode, $I_{BATT} < 1\mu A$

The three-pin header JU3 disables the voltage-regulation loop. Table 3 lists the selectable jumper options. The MAX846A EV kit is shipped configured for two Li-Ion cells with the voltage-regulation loop enabled.

Table 3. Jumper JU3 Functions

SHUNT LOCATION	OFFV PIN	CHARGER STATUS
1 & 2	Connected to VL	Voltage loop disabled
2 & 3	Connected to GND	Voltage loop enabled

The three-pin header JU4 selects the float-voltage reference. An 825k Ω , 1% resistor is provided for adjusting the float voltage. Table 4 lists the selectable jumper options. The MAX846A EV kit is shipped configured for two Li-Ion cells with the default float voltage reference at 8.4V.

Table 4. Jumper JU4 Functions

SHUNT LOCATION	VSET PIN	FLOAT VOLTAGE
1 & 2	Connected to VL	Adjust up
2 & 3	Connected to GND	Adjust down
Open	Floating	8.4V for 2 Li-Ion cells, 4.2V for 1 Li-Ion cell

The two-pin header JU5 enables adjustment of the current-regulation point. When shorted, a 10k Ω , 5% resistor (R3) connects the ISET pin to GND, and the charging current is determined by R1 and R6. During float charge, the charging current can be monitored at the ISET pin. When open, an external voltage source must be connected between ICNTRL and GND to adjust the charging current. Refer to the *Detailed Description* in the MAX846A data sheet for more information.

MAX846A Evaluation Kit

Evaluates: MAX846A

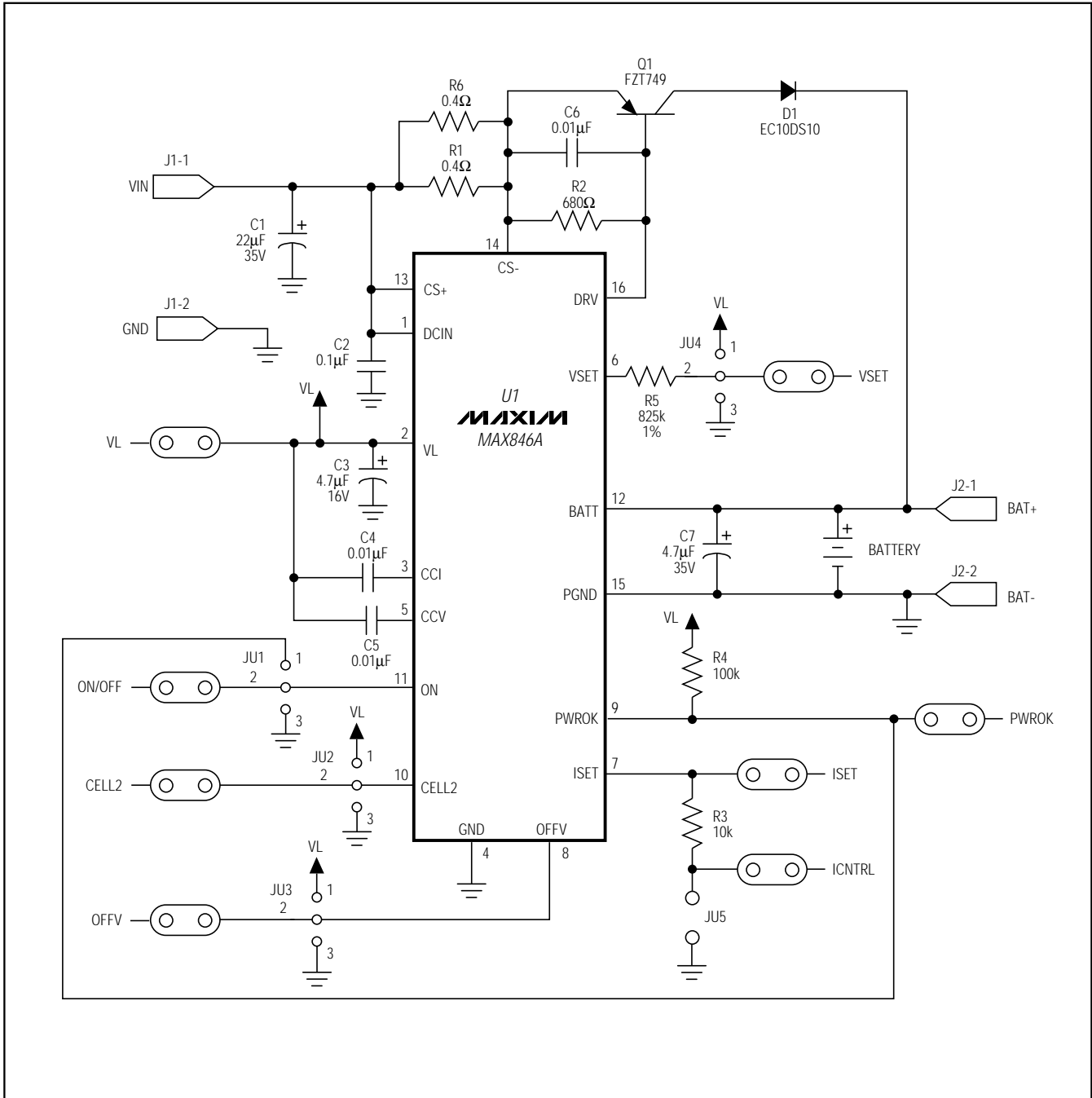

Figure 1. MAX846A EV Kit Schematic

MAX846A Evaluation Kit

Evaluates: MAX846A

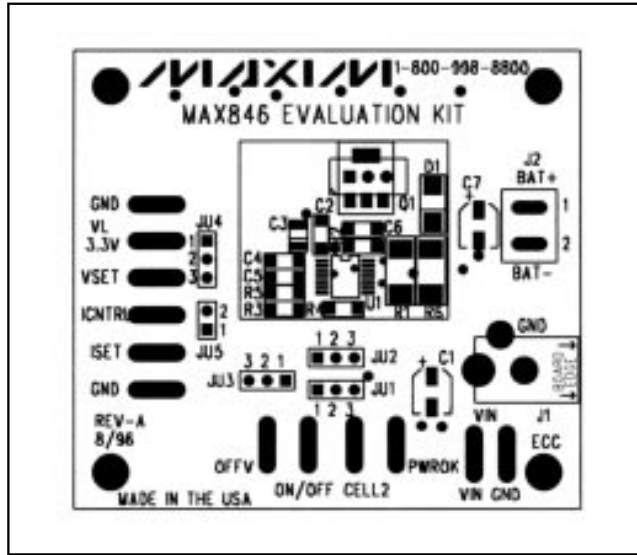

Figure 2. MAX846A EV Kit Component Placement Guide

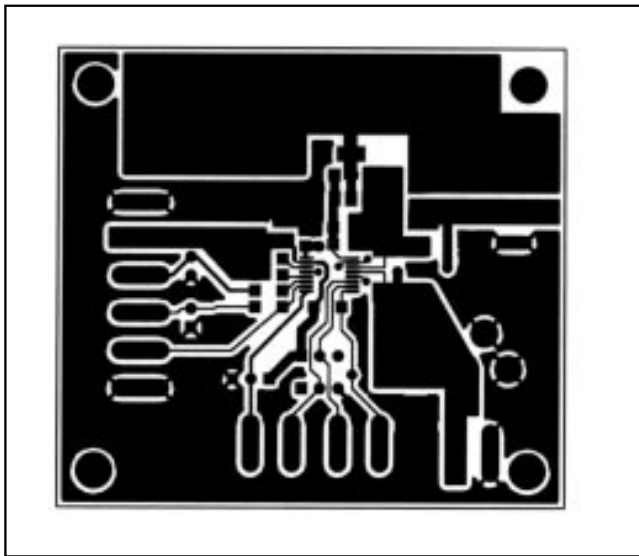

Figure 3. MAX846A EV Kit PC Board Layout—Component Side

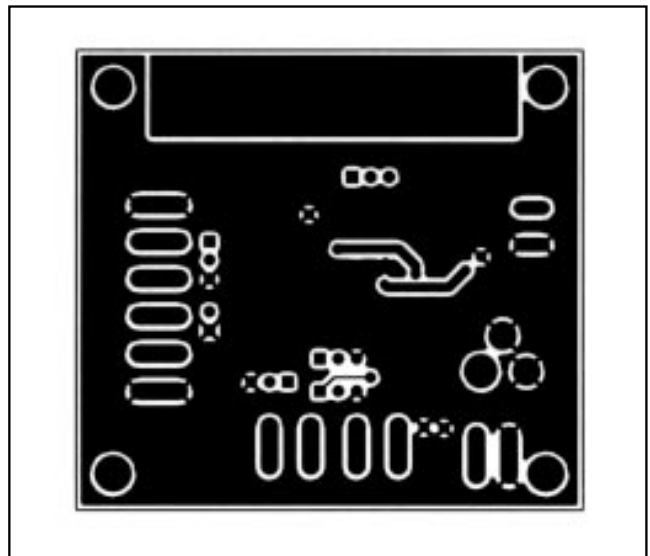

Figure 4. MAX846A EV Kit PC Board Layout—Solder Side

Maxim cannot assume responsibility for use of any circuitry other than circuitry entirely embodied in a Maxim product. No circuit patent licenses are implied. Maxim reserves the right to change the circuitry and specifications without notice at any time.

4 _____ Maxim Integrated Products, 120 San Gabriel Drive, Sunnyvale, CA 94086 (408) 737-7600

© 1996 Maxim Integrated Products

Printed USA

MAXIM is a registered trademark of Maxim Integrated Products.