

# PT2262 ENCODER PT2272 DECODER PRELIMINARY



## FEATURES

- 12 tri-state address bus supports 531, 441 codes
- Up to six data bits mode
- Good noise immunity with "noise recognition and bypass" scheme
- Encoder directly couples to IR transmitter with pulse mode DATA OUT waveform
- Optional latched or momentary data line waveform output
- High output current, directly driving transistor or TRIAC
- 3V to 15V operation

## GENERAL DESCRIPTION

The PT2262 encodes twelve bits of information and serially transmits it upon receipt of transmit enable TE, signal. The twelve inputs can be addressed with trinary data (0, 1, Floating) to allow  $3^{12}$  (531441) different codes.

There are two types of decoder available for PT2262. One is without data - PT2272 and the other is with data - PT2272-L4/M4 or PT2272-L6/M6. The PT2272 will receive the 12-bit word and consider them all as addresses while the PT2272-L4/M4 and PT2272-L6/M6 will interpret the first 8 or 6 transmitted bits as address respectively and the remaining as data. Once a received address is recognized as matching that of the decoder, a valid transmission, VT, output will go high on both types of decoders. For PT2272-L4/M4 and PT2272-L6/M6, it will output the data bits received.

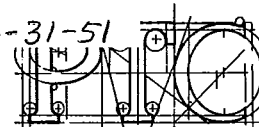

### PIN DIAGRAMS

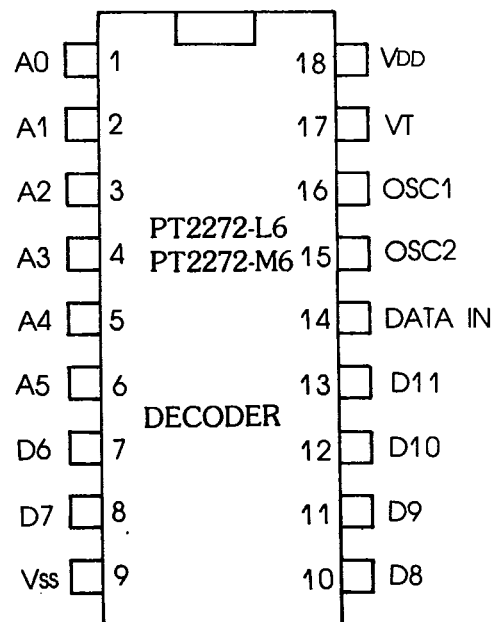
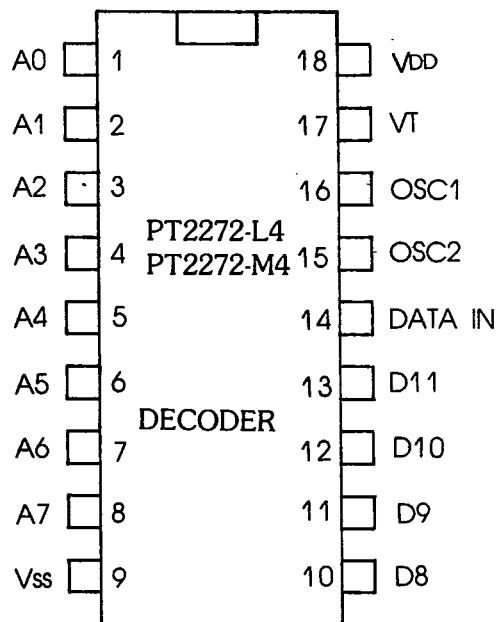
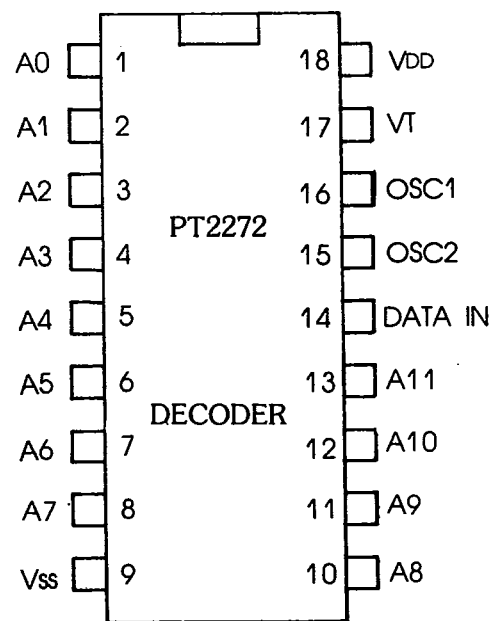
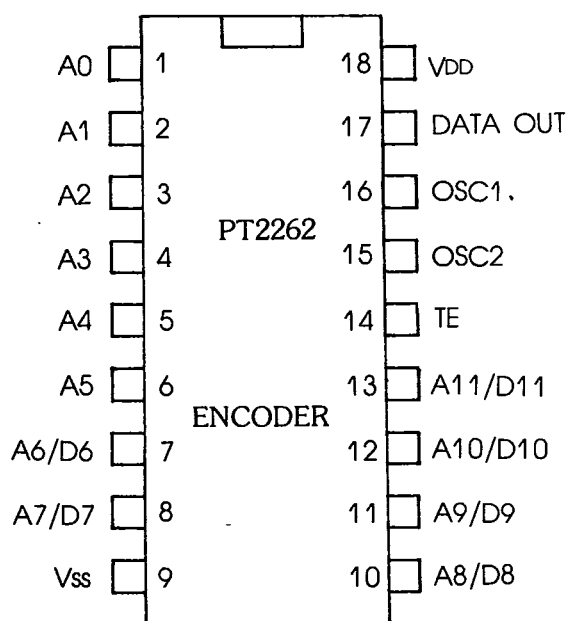

TABLE 1: PIN DESCRIPTION FOR PT2262 ENCODER

PIN NO.	NAME	FUNCTION
1-8 10-13	A0-A5 A6/D6-A11/D11	These inputs will be encoded and serially outputted from the encoder
9	Vss	The most negative supply
14	TE	This pin enables the transmission
15-16	OSC1, OSC2	These pins accept a resistor connected between them to determine the basic clock rate
17	DATA OUT	The serial output of the encoded signals
18	VDD	The most positive supply

TABLE 2: PIN DESCRIPTION FOR PT2272 DECODER

PIN NO.	NAME	FUNCTION
1-6	A0-A5	They must match the encoder inputs in order for the decoder to output data or VT signal.  Data outputs will give the information that is presented to the encoder inputs.
	PT2272 -L4/M4 -L6/M6	
7	A6 A6 D6	
8	A7 A7 D7	
10	A8 D8 D8	
11	A9 D9 D9	
12	A10 D10 D10	
13	A11 D11 D11	
9	Vss	The most negative supply
14	DATA IN	The input of the received signal
15-16	OSC1, OSC2	These pins accept a resistor connected between them to determine the basic clock rate
17	VT, VALID TRANSMISSION	This output will go high to signify a valid transmission
18	VDD	The most positive supply



### BLOCK DIAGRAM

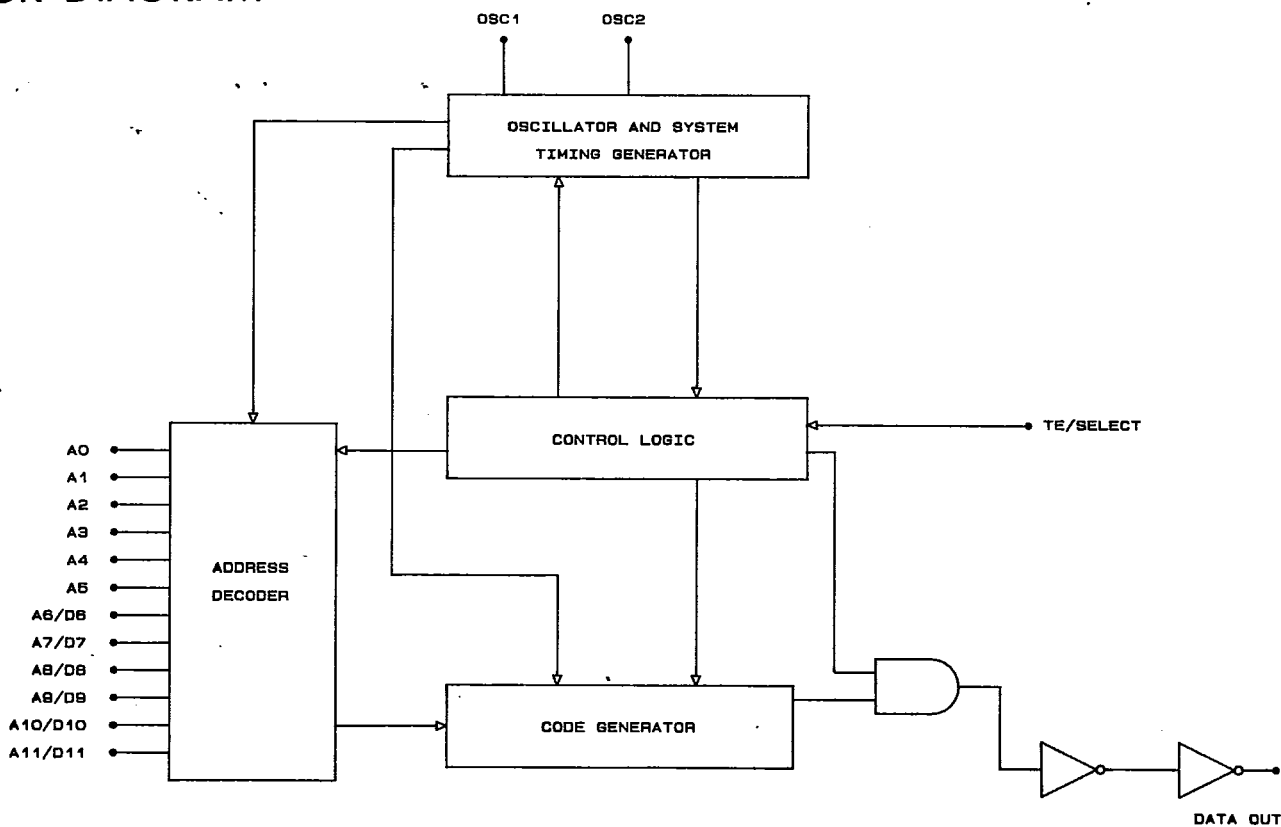

### PT2262 BLOCK DIAGRAM

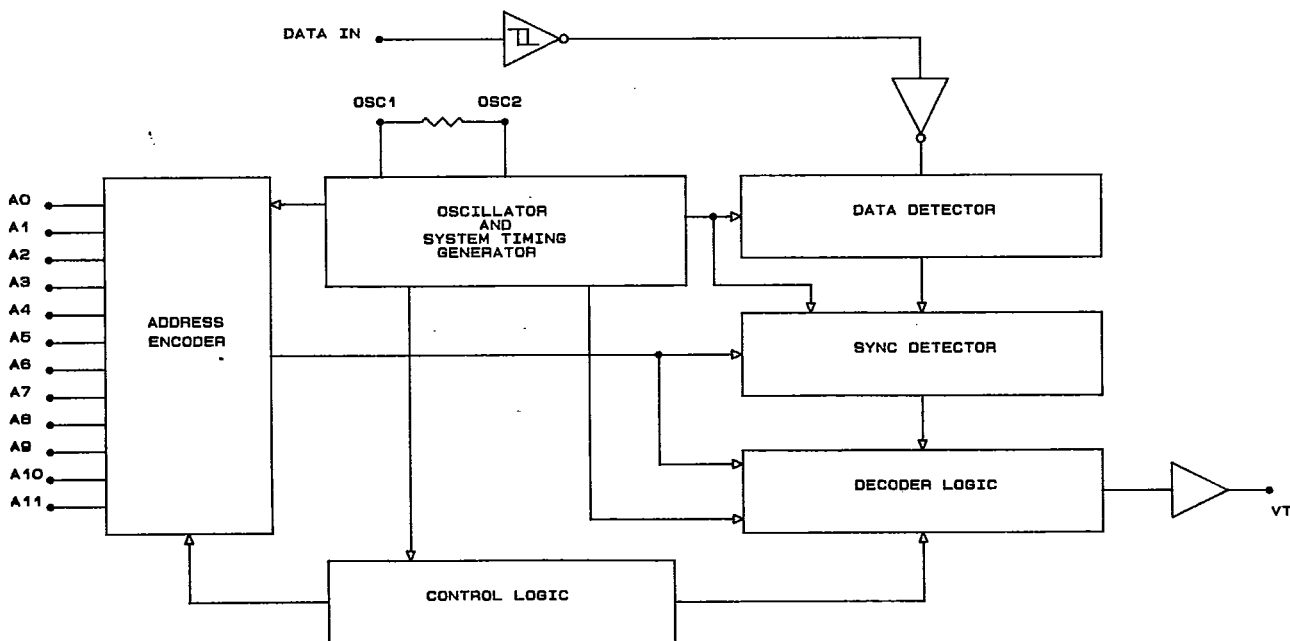

### PT-2272 BLOCK DIAGRAM

# BLOCK DIAGRAM

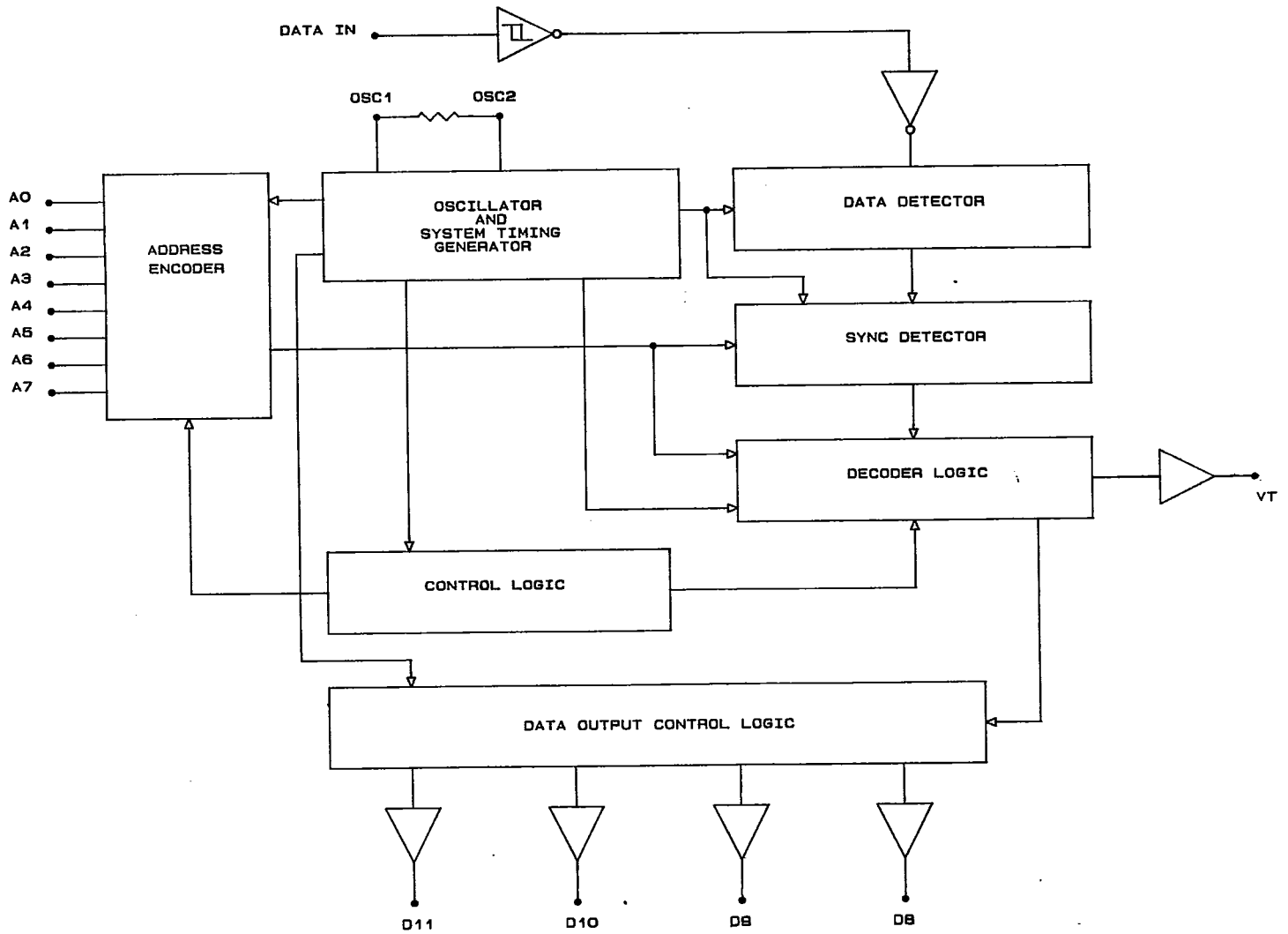

PT-2272- L4 M4 BLOCK DIAGRAM

NOTE: PT2272-L6/M6 IS IDENTICAL WITH PT-2272-L4/M4 EXCEPT FOR THE NUMBER OF DATA AND ADDRESS BITS.

# OPERATION FLOW CHART

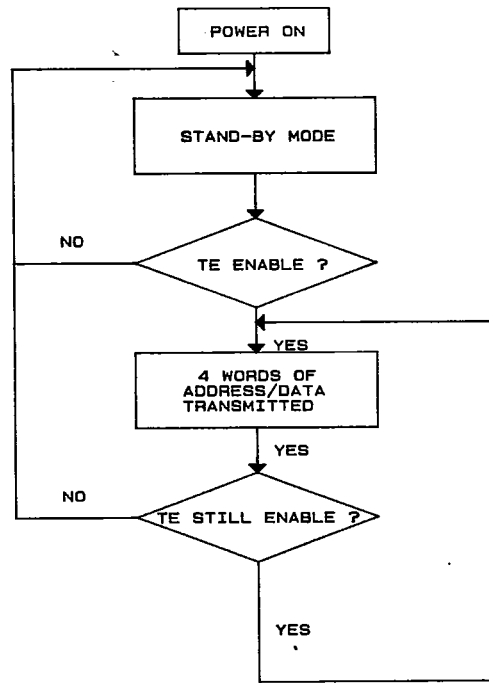

## ENCODER

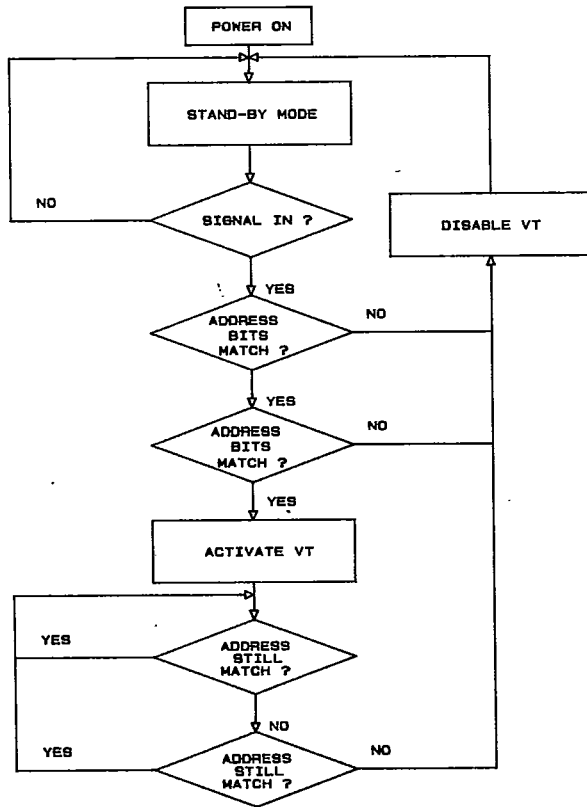

DECODER WITHOUT DATA

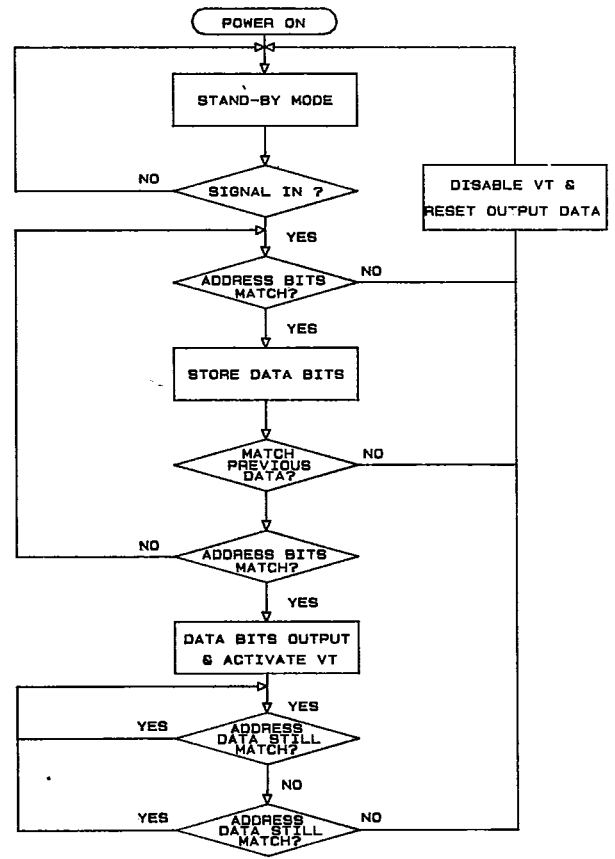

DECODER WITH DATA

# BITS WAVEFORM FROM DATA OUT PIN

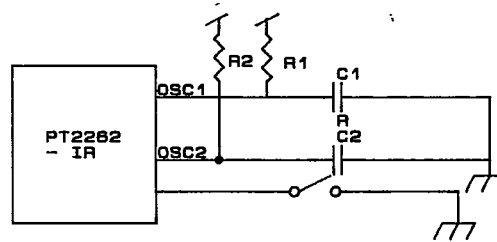
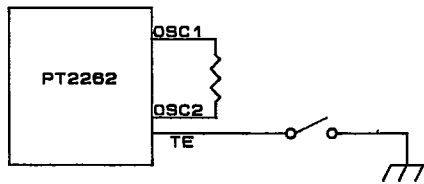
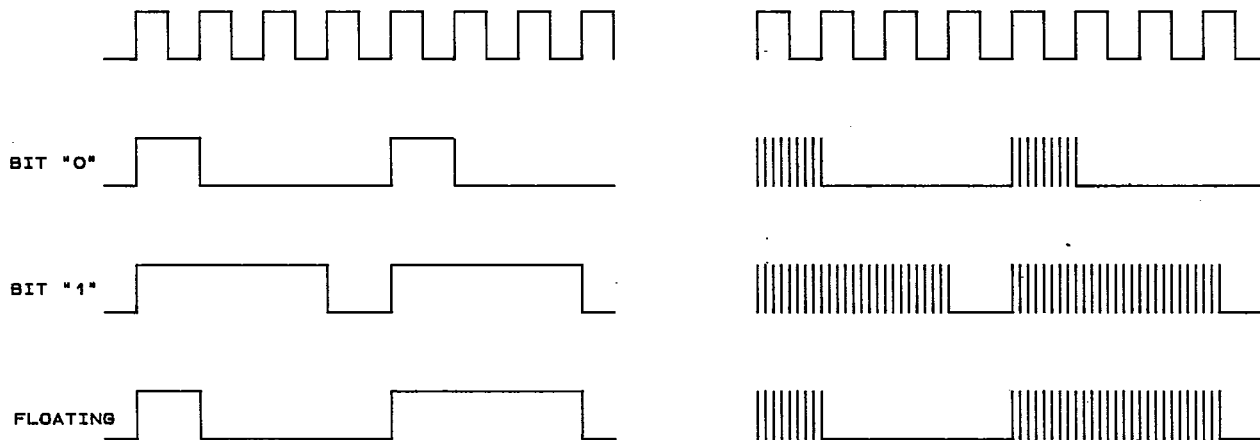

- Note:
1. In pulse waveform. The carrier pulse has very narrow duty cycle so as to achieve high transmitting ability with limited average transmitting power. The duty cycle can be adjusted by changing R1, R2, C1, C2. This scheme is most suitable for infrared application.
  2. Decoder OSC frequency must be 2.5 to 8 times as high as that of Encoder. The wide tolerance (+50%, -50%) allow the use of low precision R. We suggest 4.7M $\Omega$  in Encoder and 680K $\Omega$  in Decoder.



# TIMING DIAGRAM

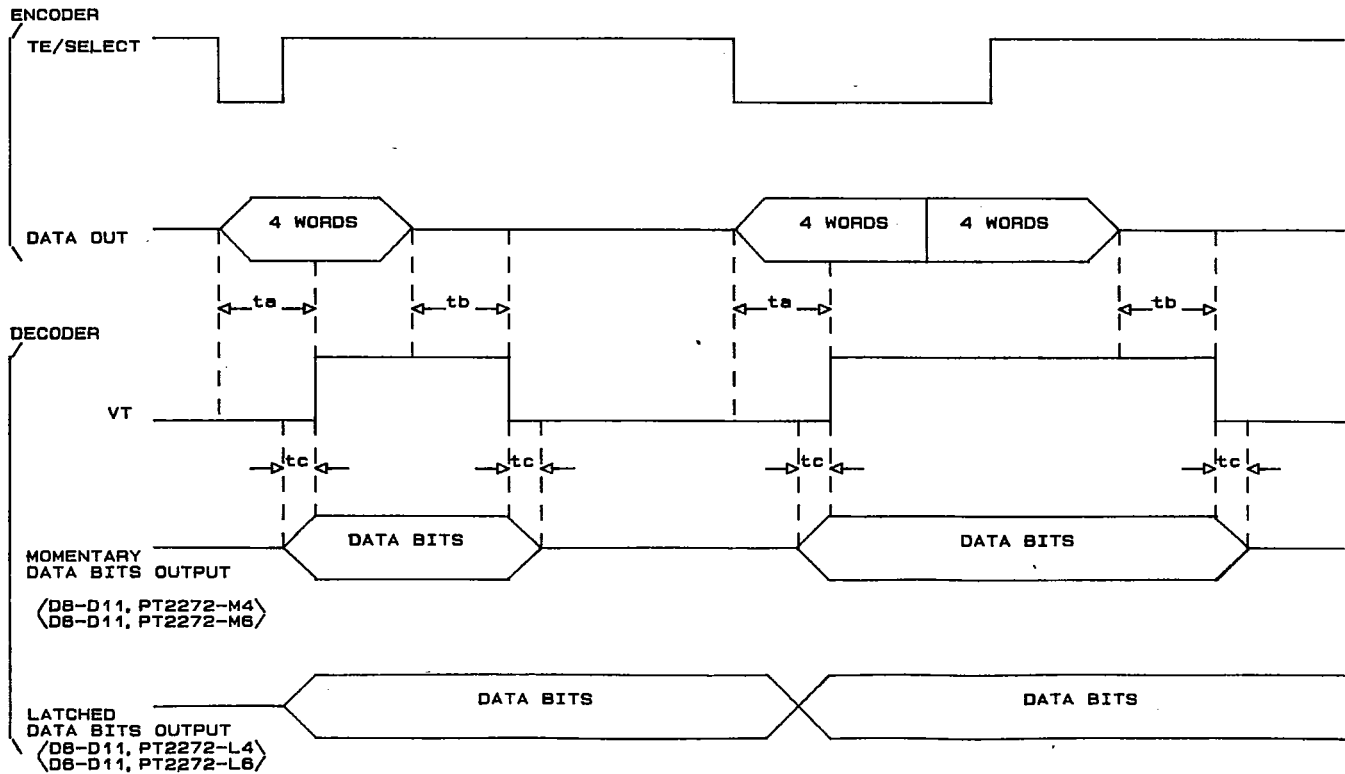

- Note: 1. In case of ideal transmission,  
 $t_a = 2 \text{ words data width (Encoder clock width} \cdot 32)$   
 $t_b = 2 \text{ words data width (Encoder clock width} \cdot 32)$   
 $t_c = 1 \text{ OSC clock width}$   
 In case that received signal is subjected to distortion or noise,  $t_a$ ,  $t_b$  may be longer. That means words of data are missed.
2.  $t_c$  is deliberately specified so as to allow VT signal to latch data bits with either rising or falling edge.



### DC CHARACTERISTICS

PARAMETER	SYMBOL	CONDITION	MIN	TYP	MAX	UNIT
Operating Voltage	V <sub>cc</sub>		3		15	V
Quiescent Current	I <sub>c</sub>	V <sub>cc</sub> =12V OCS stop A0-A11 open		0.02	0.3	μA
Output Drive Current	I <sub>OH</sub>	V <sub>cc</sub> =5V V <sub>OH</sub> =4V	4			mA
		V <sub>cc</sub> =8V V <sub>OH</sub> =4V	15			mA
PT-2272-XX (VT, D1-D6)	I <sub>OL</sub>	V <sub>cc</sub> =12V V <sub>OH</sub> =6V	40			mA
		V <sub>cc</sub> =5V V <sub>OL</sub> =1V	2			mA
		V <sub>cc</sub> =8V V <sub>OL</sub> =4V	6			mA
Output Drive Current	I <sub>OH</sub>	V <sub>cc</sub> =12V V <sub>OL</sub> =6V	12			mA
		V <sub>cc</sub> =5V V <sub>OH</sub> =3V	3			mA
		V <sub>cc</sub> =8V V <sub>OH</sub> =4V	6			mA
PT-2262 D0	I <sub>OL</sub>	V <sub>cc</sub> =12V V <sub>OH</sub> =6V	10			mA
		V <sub>cc</sub> =5V V <sub>OL</sub> =2V	2			mA
		V <sub>cc</sub> =8V V <sub>OL</sub> =4V	5			mA
		V <sub>cc</sub> =12V V <sub>OL</sub> =6V	9			mA

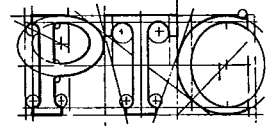

# ENCODER OSC FREQUENCY

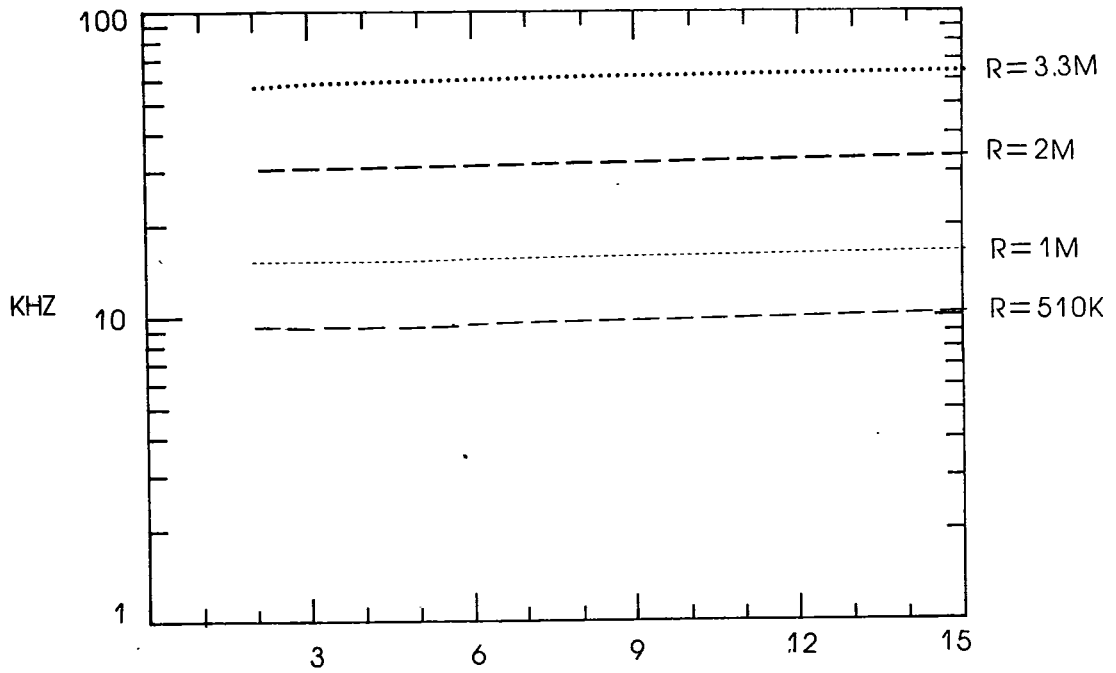

# DECODER OSC FREQUENCY

Voltage

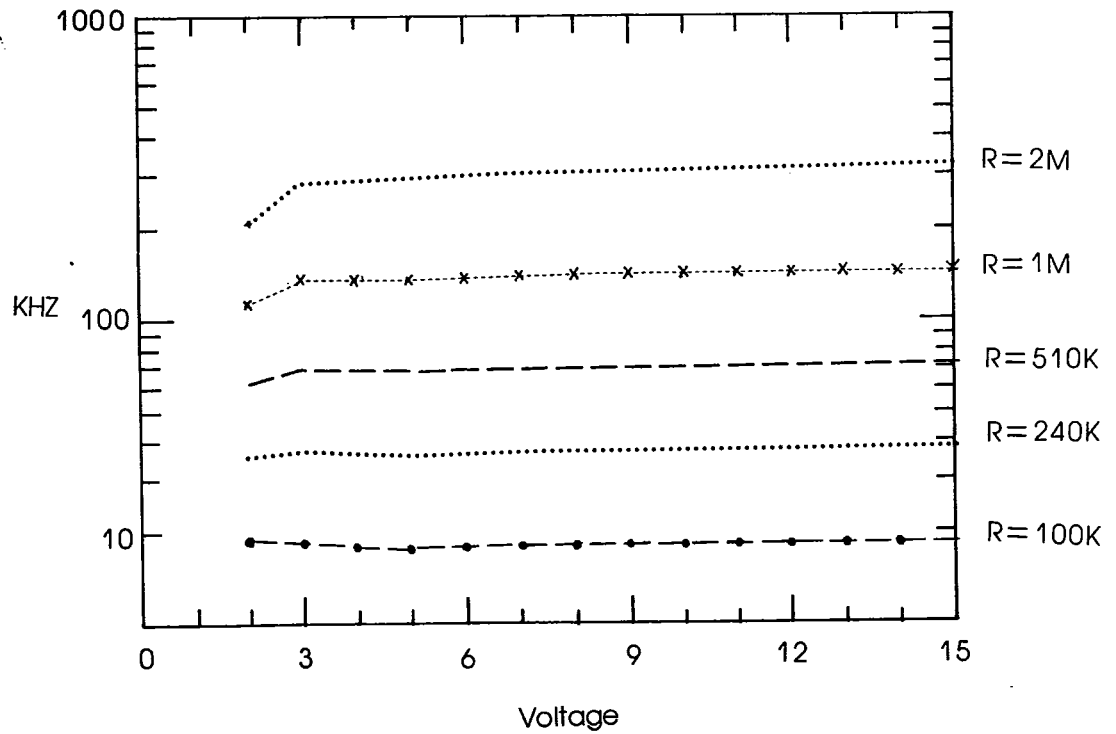

# APPLICATION CIRCUIT

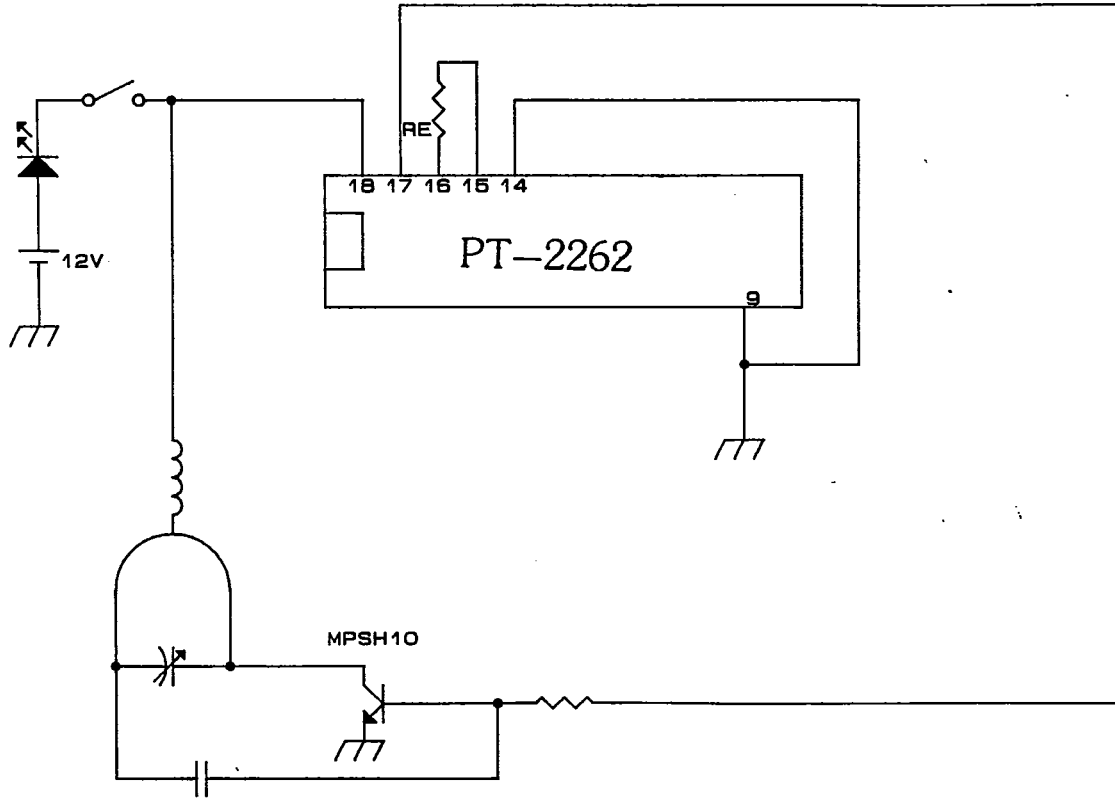

RECOMMEND UHF TRANSMITTER CIRCUIT WITHOUT ANY DATA. THIS CIRCUIT CAN SUPPORT  $3^{12} = 531441$  CODES.



# APPLICATION CIRCUIT

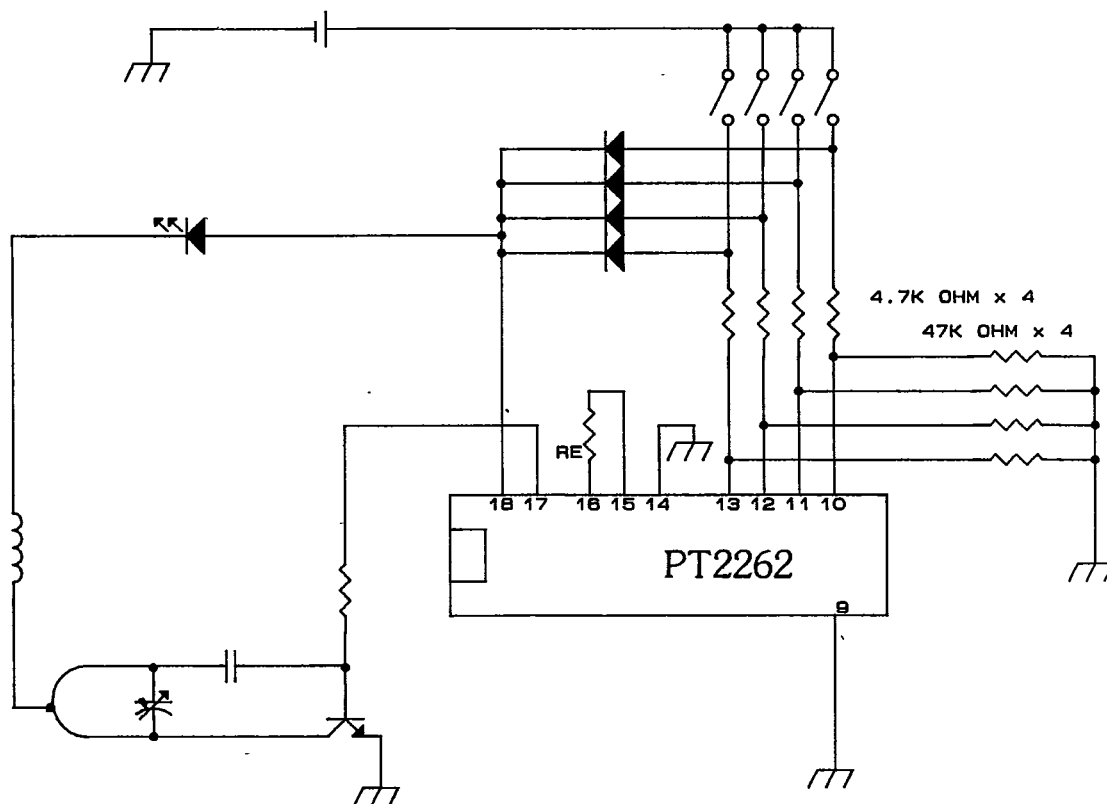

RECOMMAND UHF 4-DATA TRANSMITTER CIRCUIT.

# APPLICATION CIRCUIT

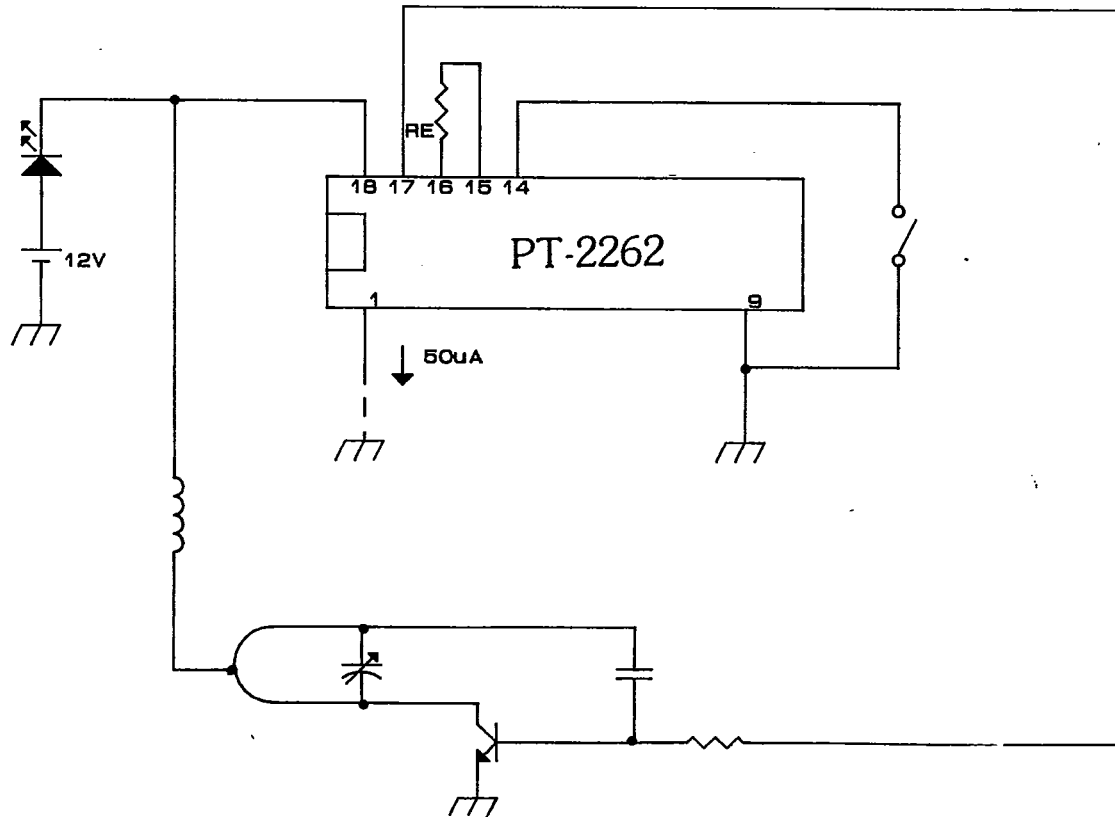

IN THIS APPLICATION CIRCUIT, ANOTHER 50µA CURRENT WILL COME FROM A0 IF A0 IS GROUNDING, THIS IS RESERVED FOR VENDER'S TESTING MODE.

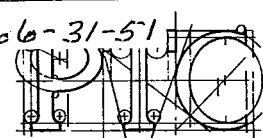

## ORDER INFORMATION

### ENCODER

PART NUMBER	WAVEFORM	PACKAGE
PT2262	Normal	18 PIN DIP
PT2262-IR	Pulse	18 PIN DIP

### DECODER

PART NUMBER	DATA BITS	WAVEFORM	PACKAGE
PT2272	0		18 PIN DIP
PT2272-L2	2	Latched	18 PIN DIP
PT2272-M2	2	Momentary	18 PIN DIP
PT2272-L4	4	Latched	18 PIN DIP
PT2272-M4	4	Momentary	18 PIN DIP
PT2272-L6	6	Latched	18 PIN DIP
PT2272-M6	6	Momentary	18 PIN DIP

NOTE: 1. Character L stands for latched data bits output.  
 2. Character M stands for momentary data bits output.

The PTC standard product code system is shown as follows:

Example: 2262  
 PT-2272-XX-E

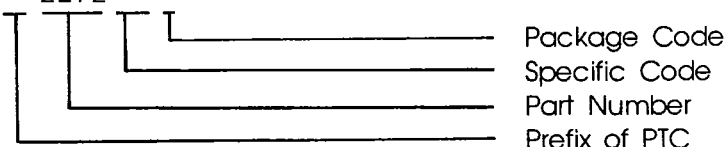

**Part Number** : 4 digits for various products

**Specific Code** : One or two digits, letters, defining specific device performance characteristics. This code will be omitted if only one version is available

**Package Code:** - : For plastic DIP, this code will be omitted  
 C : Ceramic DIP  
 F : Flat package  
 H : Chip form  
 L : Plastic Leadless Chip Carrier  
 P : Pin Grid Array  
 S : Small Outline  
 J : Plastic Leadless Chip Carrier