



**DUAL-BAND RF SYNTHESIZER WITH INTEGRATED VCOS  
FOR WIRELESS COMMUNICATIONS**

**Features**

- Dual-Band RF Synthesizers
  - RF1: 900 MHz to 1.8 GHz
  - RF2: 750 MHz to 1.5 GHz
- IF Synthesizer
  - IF: 62.5 MHz to 1000 MHz
- Integrated VCOS, Loop Filters, Varactors, and Resonators
- Minimal (2) External Components Required
- Low Phase Noise
- Programmable Power Down Modes
- 1  $\mu$ A Standby Current
- 18 mA Typical Supply Current
- 2.7 V to 3.6 V Operation
- Packages: 24-Pin TSSOP, 28-Lead MLP

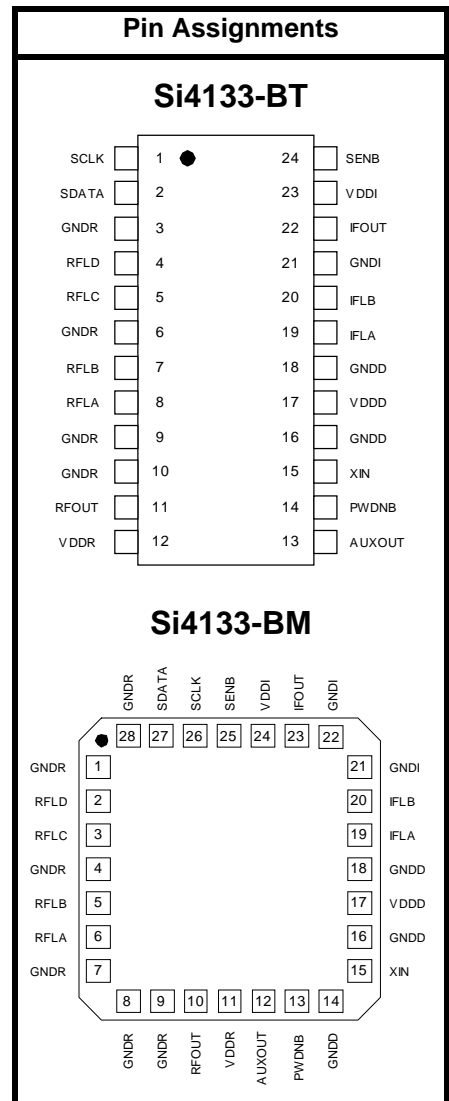
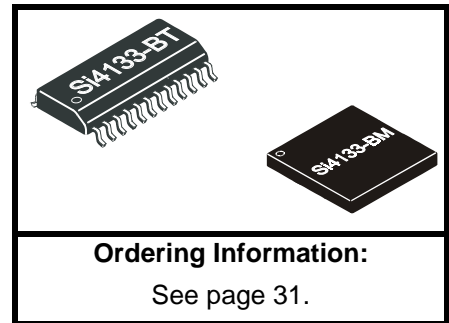
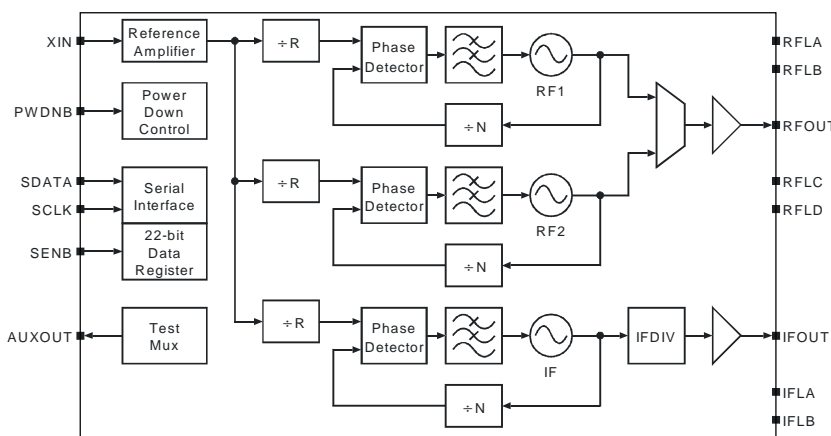
**Applications**

- Dual-Band Communications
- Digital Cellular Telephones
- GSM, DCS1800, PCS1900
- Digital Cordless Phones
- Analog Cordless Phones
- Wireless LAN and WAN

**Description**

The Si4133 is a monolithic integrated circuit that performs both IF and dual-band RF synthesis for wireless communications applications. The Si4133 includes three VCOS, loop filters, reference and VCO dividers, and phase detectors. Divider and power-down settings are programmable through a three-wire serial interface.

**Functional Block Diagram**



Patents pending



---

**TABLE OF CONTENTS**


---

<b><u>Section</u></b>	<b><u>Page</u></b>
<b>Electrical Specifications</b> .....	<b>4</b>
<b>Functional Description</b> .....	<b>16</b>
Serial Interface .....	16
Setting the VCO Center Frequencies .....	16
Extended Frequency Operation .....	17
Self-Tuning Algorithm .....	17
Output Frequencies .....	18
PLL Loop Dynamics .....	18
RF and IF Outputs .....	19
Reference Frequency Amplifier .....	19
Power Down Modes .....	19
Auxiliary Output (AUXOUT) .....	20
<b>Control Registers</b> .....	<b>21</b>
<b>Pin Descriptions: Si4133-BT</b> .....	<b>27</b>
<b>Pin Descriptions: Si4133-BM</b> .....	<b>29</b>
<b>Ordering Guide</b> .....	<b>31</b>
<b>Si4133 Derivative Devices</b> .....	<b>31</b>
<b>Package Outline: Si4133-BT</b> .....	<b>32</b>
<b>Package Outline: Si4133-BM</b> .....	<b>33</b>
<b>Contact Information</b> .....	<b>34</b>



## Electrical Specifications

**Table 1. Recommended Operating Conditions**

Parameter	Symbol	Test Condition	Min	Typ	Max	Unit
Ambient Temperature	$T_A$		-40	25	85	°C
Supply Voltage	$V_{DD}$		2.7	3.0	3.6	V
Supply Voltages Difference	$V_{\Delta}$	$(V_{DDR} - V_{DDD}),$ $(V_{DDI} - V_{DDD})$	-0.3	—	0.3	V

**Note:** All minimum and maximum specifications are guaranteed and apply across the recommended operating conditions. Typical values apply at nominal supply voltages and an operating temperature of 25°C unless otherwise stated.

**Table 2. Absolute Maximum Ratings<sup>1,2</sup>**

Parameter	Symbol	Value	Unit
DC Supply Voltage	$V_{DD}$	-0.5 to 4.0	V
Input Current <sup>3</sup>	$I_{IN}$	±10	mA
Input Voltage <sup>3</sup>	$V_{IN}$	-0.3 to $V_{DD}+0.3$	V
Storage Temperature Range	$T_{STG}$	-55 to 150	°C

**Notes:**

1. Permanent device damage may occur if the above Absolute Maximum Ratings are exceeded. Functional operation should be restricted to the conditions as specified in the operational sections of this data sheet. Exposure to absolute maximum rating conditions for extended periods may affect device reliability.
2. **This device is a high performance RF integrated circuit with an ESD rating of < 2 kV. Handling and assembly of this device should only be done at ESD-protected workstations.**
3. For signals SCLK, SDATA, SENB, PWDNB and XIN.

**Table 3. DC Characteristics** $(V_{DD} = 2.7 \text{ to } 3.6 \text{ V}, T_A = -40 \text{ to } 85^\circ\text{C})$ 

Parameter	Symbol	Test Condition	Min	Typ	Max	Unit
Total Supply Current <sup>1</sup>		RF1 and IF operating	—	18	27	mA
RF1 Mode Supply Current <sup>1</sup>			—	10	16	mA
RF2 Mode Supply Current <sup>1</sup>			—	9	16	mA
IF Mode Supply Current <sup>1</sup>			—	8	13	mA
Standby Current		PWDNB = 0	—	1	—	$\mu\text{A}$
High Level Input Voltage <sup>2</sup>	$V_{IH}$		$0.7 V_{DD}$	—	—	V
Low Level Input Voltage <sup>2</sup>	$V_{IL}$		—	—	$0.3 V_{DD}$	V
High Level Input Current <sup>2</sup>	$I_{IH}$	$V_{IH} = 3.6 \text{ V},$ $V_{DD} = 3.6 \text{ V}$	-10	—	10	$\mu\text{A}$
Low Level Input Current <sup>2</sup>	$I_{IL}$	$V_{IL} = 0 \text{ V},$ $V_{DD} = 3.6 \text{ V}$	-10	—	10	$\mu\text{A}$
High Level Output Voltage <sup>3</sup>	$V_{OH}$	$I_{OH} = -500 \mu\text{A}$	$V_{DD} - 0.4$	—	—	V
Low Level Output Voltage <sup>3</sup>	$V_{OL}$	$I_{OH} = 500 \mu\text{A}$	—	—	0.4	V

**Notes:**

1. RF1 = 1.6 GHz, RF2 = 1.1 GHz, IFOUT = 550 MHz, LPWR = 0
2. For signals SCLK, SDATA, SENB, and PWDNB.
3. For signal AUXOUT.

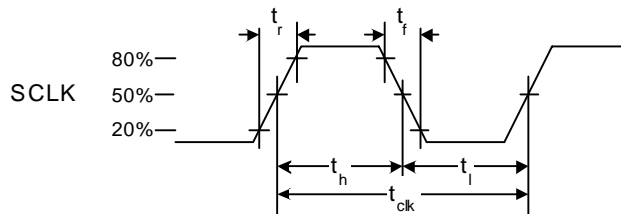


**Table 4. Serial Interface Timing**  
 ( $V_{DD} = 2.7$  to  $3.6$  V,  $T_A = -40$  to  $85^\circ\text{C}$ )

Parameter <sup>1</sup>	Symbol	Test Condition	Min	Typ	Max	Unit
SCLK Cycle Time	$t_{clk}$	Figure 1	40	—	—	ns
SCLK Rise Time	$t_r$	Figure 1	—	—	50	ns
SCLK Fall Time	$t_f$	Figure 1	—	—	50	ns
SCLK High Time	$t_h$	Figure 1	10	—	—	ns
SCLK Low Time	$t_l$	Figure 1	10	—	—	ns
SDATA Setup Time to SCLK $\uparrow$ <sup>2</sup>	$t_{su}$	Figure 2	5	—	—	ns
SDATA Hold Time from SCLK $\uparrow$ <sup>2</sup>	$t_{hold}$	Figure 2	0	—	—	ns
SENB $\downarrow$ to SCLK $\uparrow$ Delay Time <sup>2</sup>	$t_{en1}$	Figure 2	10	—	—	ns
SCLK $\uparrow$ to SENB $\uparrow$ Delay Time <sup>2</sup>	$t_{en2}$	Figure 2	12	—	—	ns
SENB $\uparrow$ to SCLK $\uparrow$ Delay Time <sup>2</sup>	$t_{en3}$	Figure 2	12	—	—	ns
SENB Pulse Width	$t_w$	Figure 2	10	—	—	ns

**Notes:**

1. All timing is referenced to the 50% level of the waveforms unless otherwise noted.
2. Timing is not referenced to 50% level of the waveform. See Figure 2.



**Figure 1. SCLK Timing Diagram**

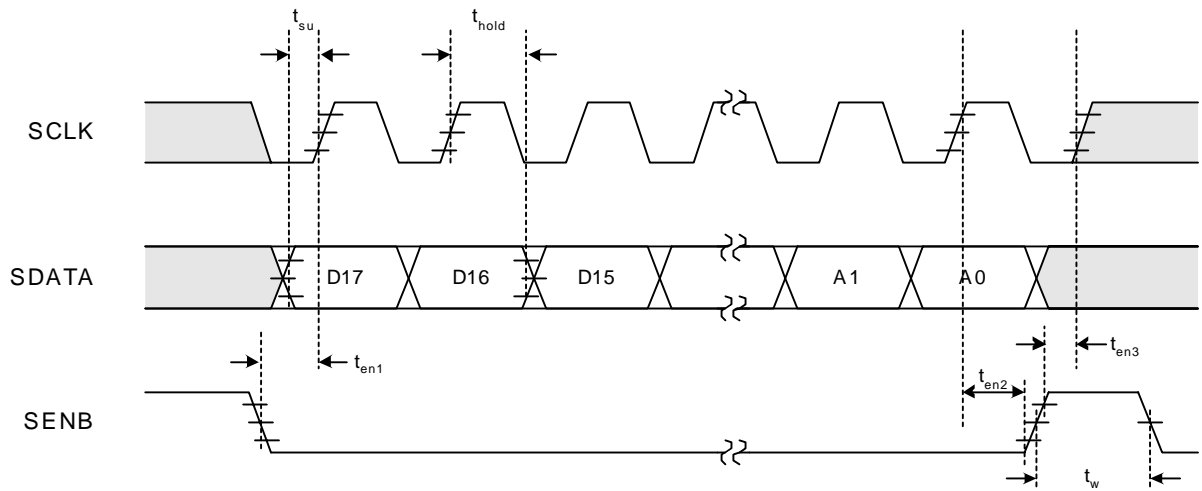


Figure 2. Serial Interface Timing Diagram

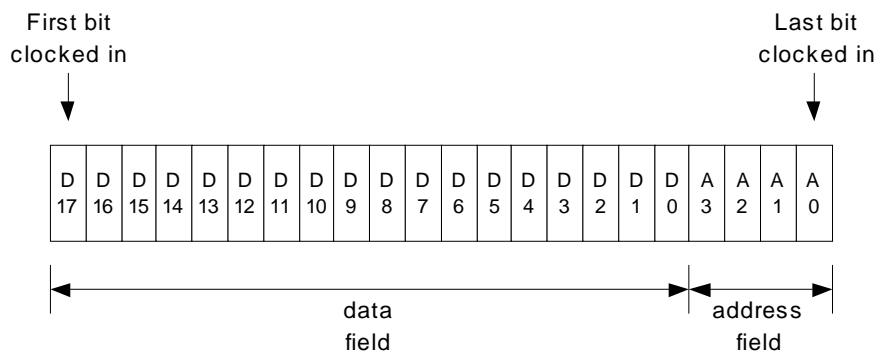


Figure 3. Serial Word Format

**Table 5. RF and IF Synthesizer Characteristics** $(V_{DD} = 2.7 \text{ to } 3.6 \text{ V}, T_A = -40 \text{ to } 85^\circ\text{C})$ 

Parameter <sup>1</sup>	Symbol	Test Condition	Min	Typ	Max	Unit
XIN Input Frequency	$f_{REF}$		2	—	26	MHz
Reference Amplifier Sensitivity	$V_{REF}$		0.5	—	$V_{DD} + 0.3 \text{ V}$	$V_{P-P}$
Phase Detector Update Frequency	$f_\phi$	$f_\phi = f_{REF}/R$	0.010	—	1.0	MHz
RF1 VCO Center Frequency Range	$f_{CEN}$		947	—	1720	MHz
RF1 VCO Tuning Range <sup>2</sup>		Extended frequency operation	1850	—	2050	MHz
RF2 VCO Center Frequency Range	$f_{CEN}$		789	—	1429	MHz
RF Tuning Range from $f_{CEN}$		Note: $L_{EXT} \pm 10\%$	-5	—	5	%
IF VCO Center Frequency Range	$f_{CEN}$		526	—	952	MHz
IFOUT Tuning Range		with IFDIV	62.5	—	1000	MHz
IFOUT Tuning Range from $f_{CEN}$		Note: $L_{EXT} \pm 10\%$	-5	—	5	%
RF1 VCO Pushing		Open loop	—	500	—	kHz/V
RF2 VCO Pushing			—	400	—	kHz/V
IF VCO Pushing			—	300	—	kHz/V
RF1 VCO Pulling		VSWR = 2:1, all phases, open loop	—	900	—	MHz
RF2 VCO Pulling			—	300	—	kHz
IF VCO Pulling			—	100	—	kHz
RF1 Phase Noise		1 MHz offset	—	-132	—	dBc/Hz
RF1 Integrated Phase Error		10 Hz to 100 kHz	—	0.9	—	degrees rms
RF2 Phase Noise		1 MHz offset	—	-134	—	dBc/Hz
RF2 Integrated Phase Error		10 Hz to 100 kHz	—	0.7	—	degrees rms
IF Phase Noise		100 kHz offset	—	-117	—	dBc/Hz
IF Integrated Phase Error		100 Hz to 100 kHz	—	0.4	—	degrees rms

**Notes:**

- $f_\phi = 200 \text{ kHz}$ , RF1 = 1.6 GHz, RF2 = 1.2 GHz, IFOUT = 550 MHz, LPWR = 0, for all parameters unless otherwise noted.
- Extended frequency operation only.  $V_{DD} \geq 3.0 \text{ V}$ , MLP only, VCO Tuning Range fixed by directly shorting the RFLA and RFLB pins. See Application Note 41 for more details on the Si4133 extended frequency operation.
- From power up request (PWRDN $\uparrow$  or SENB $\uparrow$  during a write of 1 to bits PDIB and PDRB in Register 2) to RF and IF synthesizers ready (settled to within 0.1 ppm frequency error).
- From power down request (PWRDN $\downarrow$ , or SENB $\uparrow$  during a write of 0 to bits PDIB and PDRB in Register 2) to supply current equal to  $I_{PWRDN}$ .



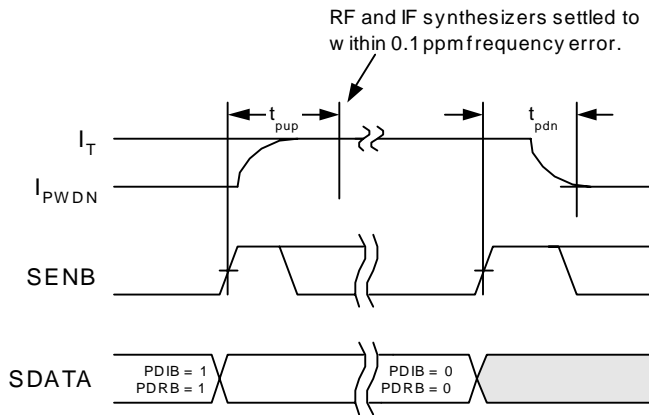
**Table 5. RF and IF Synthesizer Characteristics (Continued)** $(V_{DD} = 2.7$  to  $3.6$  V,  $T_A = -40$  to  $85^\circ\text{C}$ )

Parameter <sup>1</sup>	Symbol	Test Condition	Min	Typ	Max	Unit
RF1 Harmonic Suppression		Second Harmonic	—	-26	-20	dBc
RF2 Harmonic Suppression			—	-26	-20	dBc
IF Harmonic Suppression			—	-26	-20	dBc
RFOUT Power Level		$Z_L = 50 \Omega$	-8	-3	1	dBm
RFOUT Power Level <sup>2</sup>		$Z_L = 50 \Omega$ , RF1 active, Extended frequency operation	-14	-7	1	dBm
IFOUT Power Level		$Z_L = 50 \Omega$	-8	-4	0	dBm
RF1 Output Reference Spurs		Offset = 200 kHz	—	-65	—	dBc
		Offset = 400 kHz	—	-71	—	dBc
		Offset = 600 kHz	—	-75	—	dBc
RF2 Output Reference Spurs		Offset = 200 kHz	—	-65	—	dBc
		Offset = 400 kHz	—	-71	—	dBc
		Offset = 600 kHz	—	-75	—	dBc
Power Up Request to Synthesizer Ready <sup>3</sup> Time	$t_{pup}$	Figures 4, 5	—	$40/f_\phi$	$50/f_\phi$	
Power Down Request to Synthesizer Off <sup>4</sup> Time	$t_{pdn}$	Figures 4, 5	—	—	100	ns

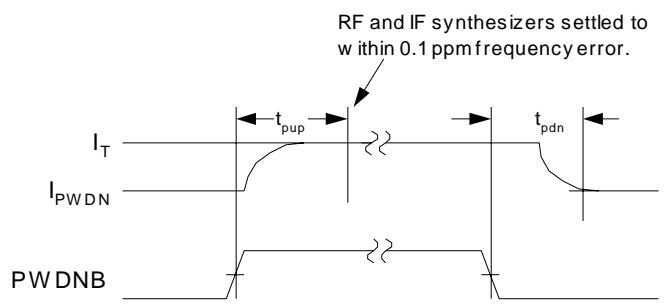
**Notes:**

- $f_\phi = 200$  kHz, RF1 = 1.6 GHz, RF2 = 1.2 GHz, IFOUT = 550 MHz, LPWR = 0, for all parameters unless otherwise noted.
- Extended frequency operation only.  $V_{DD} \geq 3.0$  V, MLP only, VCO Tuning Range fixed by directly shorting the RFLA and RFLB pins. See Application Note 41 for more details on the Si4133 extended frequency operation.
- From power up request (PWDNB $\uparrow$  or SENB $\uparrow$  during a write of 1 to bits PDIB and PDRB in Register 2) to RF and IF synthesizers ready (settled to within 0.1 ppm frequency error).
- From power down request (PWDNB $\downarrow$ , or SENB $\uparrow$  during a write of 0 to bits PDIB and PDRB in Register 2) to supply current equal to  $I_{P_{WPN}}$ .

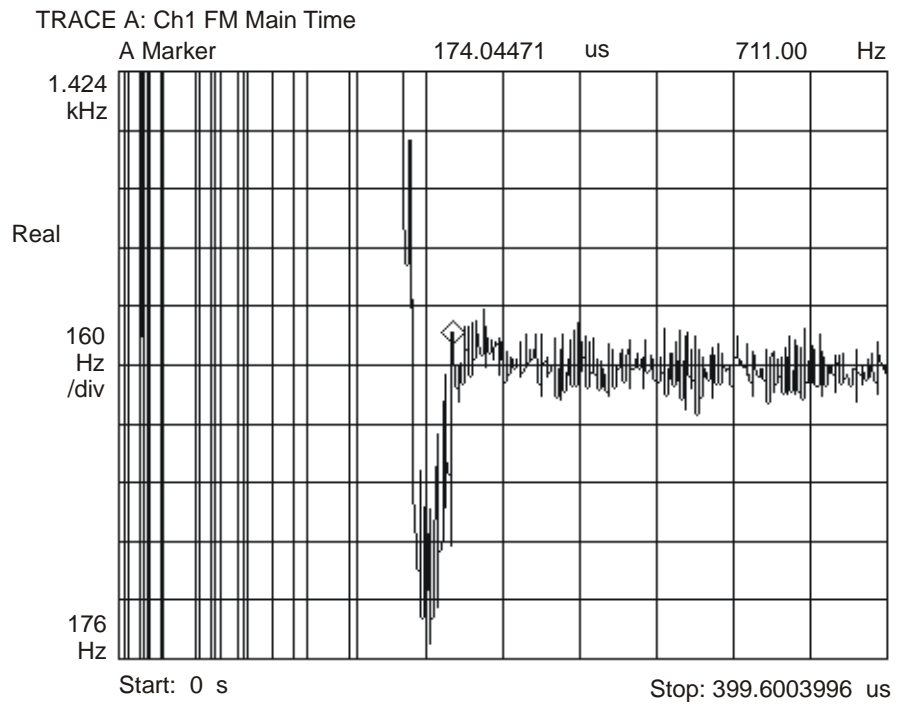




**Figure 4. Software Power Management Timing Diagram**



**Figure 5. Hardware Power Management Timing Diagram**



**Figure 6. Typical Transient Response RF1 at 1.6 GHz with 200 kHz Phase Detector Update Frequency**

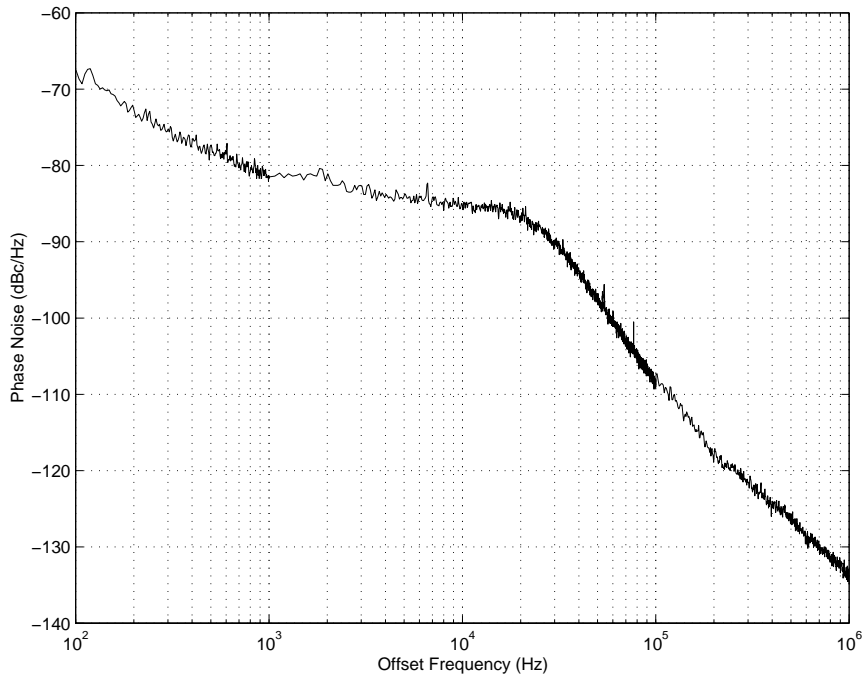


Figure 7. Typical RF1 Phase Noise at 1.6 GHz with 200 kHz Phase Detector Update Frequency

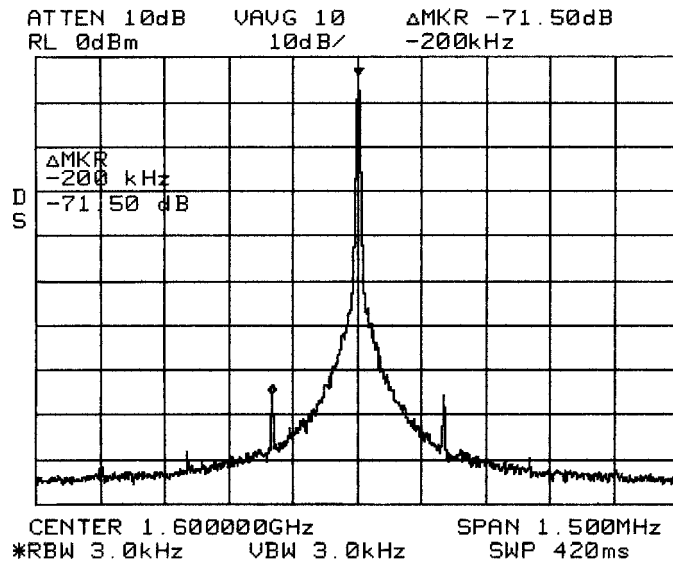
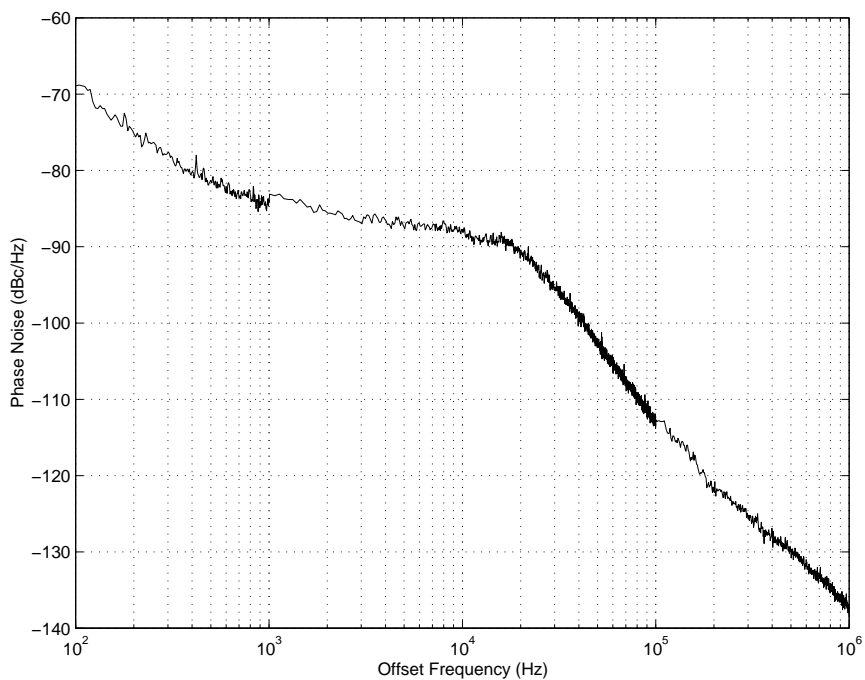
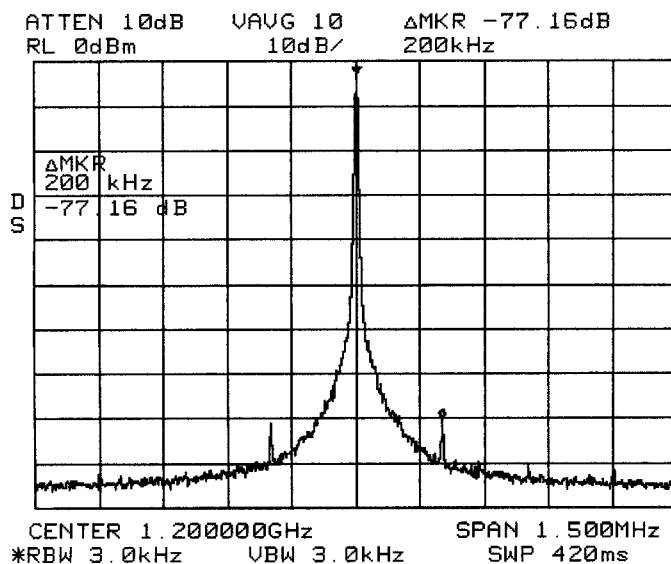


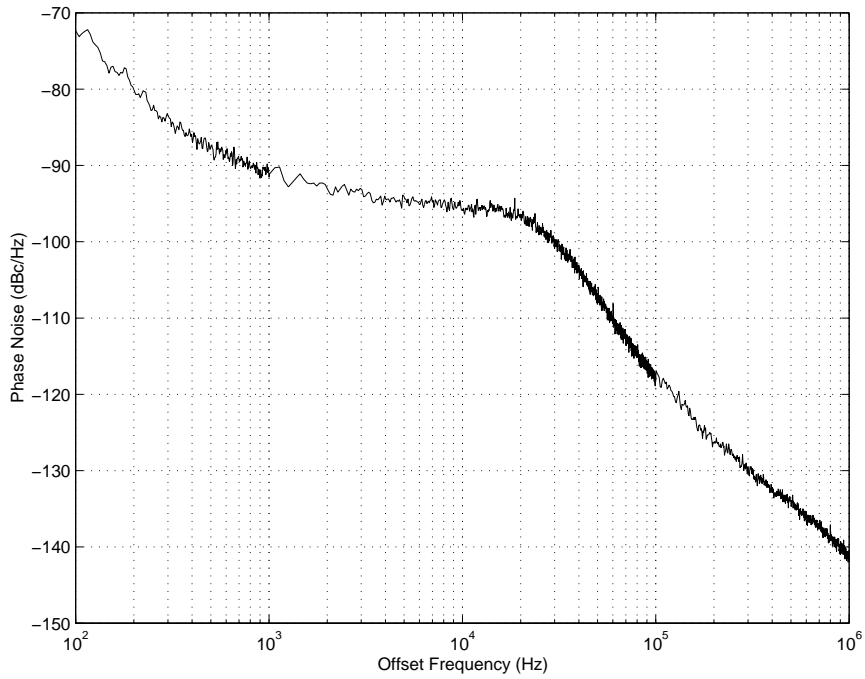
Figure 8. Typical RF1 Spurious Response at 1.6 GHz with 200 kHz Phase Detector Update Frequency



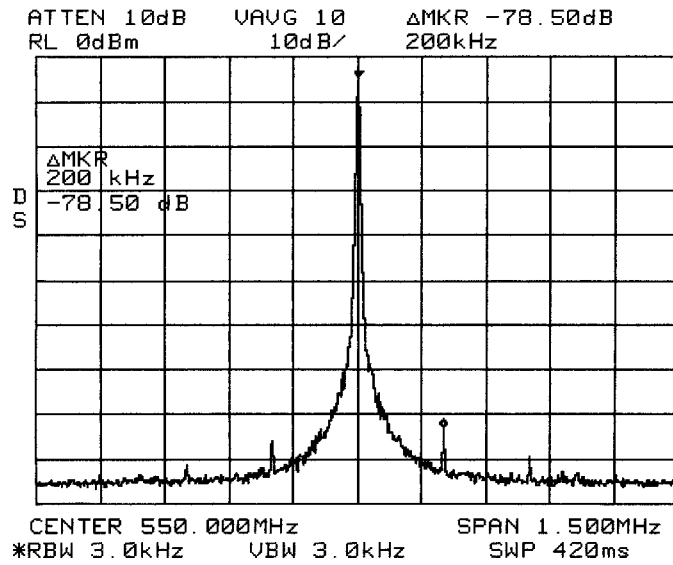
**Figure 9. Typical RF2 Phase Noise at 1.2 GHz with 200 kHz Phase Detector Update Frequency**



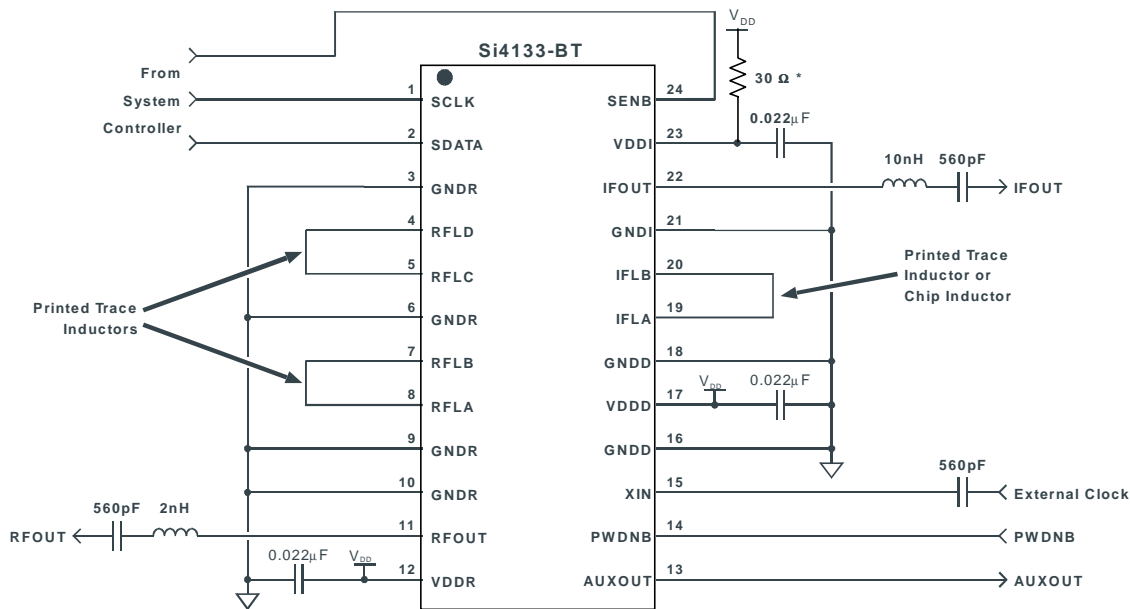
**Figure 10. Typical RF2 Spurious Response at 1.2 GHz with 200 kHz Phase Detector Update Frequency**



**Figure 11. Typical IF Phase Noise at 550 MHz with 200 kHz Phase Detector Update Frequency**

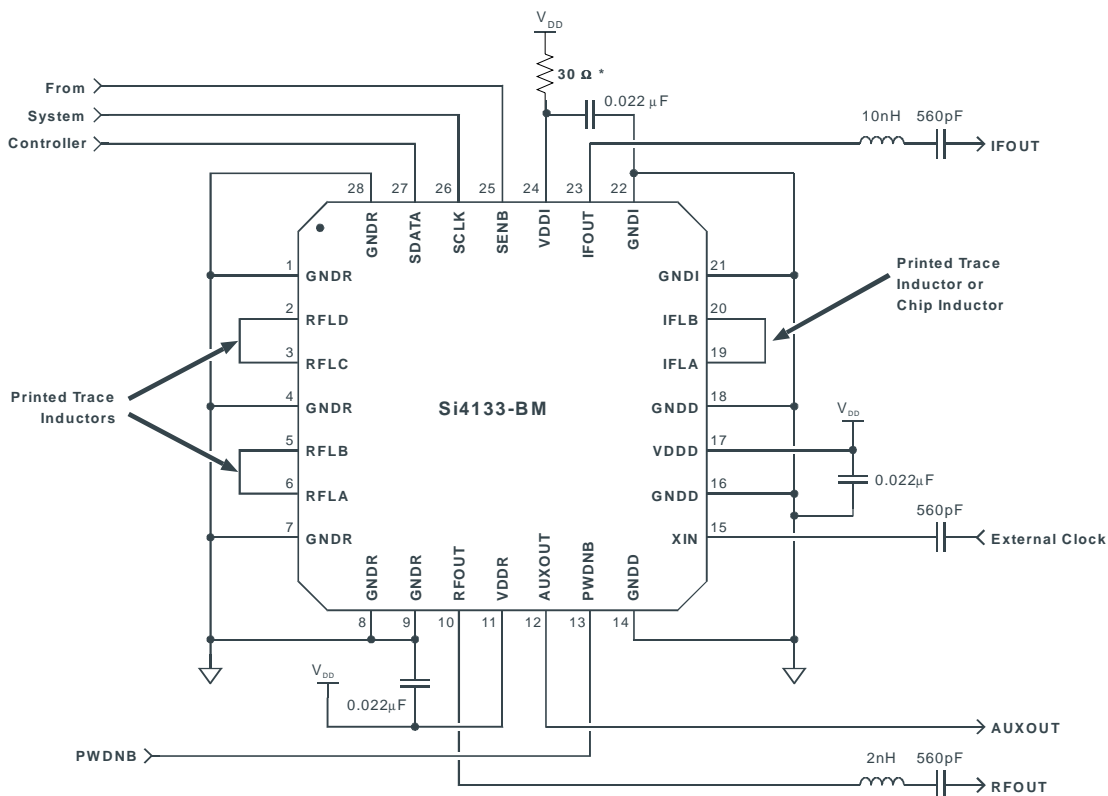


**Figure 12. IF Spurious Response at 550 MHz with 200 kHz Phase Detector Update Frequency**



\* Add 30 Ω series resistance if using IF output divide values 2, 4, or 8.

**Figure 13. Typical Application Circuit: Si4133-BT**



\* Add 30 Ω series resistance if using IF output divide values 2, 4, or 8.

**Figure 14. Typical Application Circuit: Si4133-BM**

## Functional Description

The Si4133 is a monolithic integrated circuit that performs IF and dual-band RF synthesis for wireless communications applications. This integrated circuit (IC), with minimal external components, completes the frequency synthesis function necessary for RF communications systems.

The Si4133 has three complete phase-locked loops (PLLs) with integrated voltage-controlled oscillators (VCOs). The low phase noise of the VCOs makes the Si4133 suitable for use in demanding wireless communications applications. Phase detectors, loop filters, and reference and output frequency dividers are integrated. The IC is programmed through a three-wire serial interface.

Two PLLs are provided for dual-band RF synthesis. These RF PLLs are multiplexed so that only one PLL is active at a given time (as determined by the setting of an internal register). The active PLL is the last one written. The center frequency of the VCO in each PLL is set by the value of an external inductance. Inaccuracies in these inductances are compensated for by the self-tuning algorithm. The algorithm is run following power-up or following a change in the programmed output frequency.

Each RF PLL, when active, can adjust the RF output frequency by  $\pm 5\%$  of its VCO's center frequency. Because the two VCOs can be set to have widely separated center frequencies, the RF output can be programmed to service two widely separated frequency bands by simply programming the corresponding N-Divider. One RF VCO is optimized to have its center frequency set between 947 MHz and 1.72 GHz, while the second RF VCO is optimized to have its center frequency set between 789 MHz and 1.429 GHz.

One PLL is provided for IF frequency synthesis. The center frequency of this circuit's VCO is set by connection of an external inductance. The PLL can adjust the IF output frequency by  $\pm 5\%$  of the VCO center frequency. Inaccuracies in the value of the external inductance are compensated for by the Si4133's proprietary self-tuning algorithm. This algorithm is initiated each time the PLL is powered-up (by either the PWDNB pin or by software) and/or each time a new output frequency is programmed.

The IF VCO can have its center frequency set as low as 526 MHz and as high as 952 MHz. An IF output divider is provided to divide down the IF output frequencies, if needed. The divider is programmable, capable of dividing by 1, 2, 4, or 8.

The unique PLL architecture used in the Si4133 produces settling (lock) times that are comparable in speed to fractional-N architectures without suffering the high phase noise or spurious modulation effects often associated with those designs.

## Serial Interface

A timing diagram for the serial interface is shown in Figure 2 on page 7. Figure 3 on page 7 shows the format of the serial word.

The Si4133 is programmed serially with 22-bit words comprised of 18-bit data fields and 4-bit address fields. When the serial interface is enabled (i.e., when SENB is low) data and address bits on the SDATA pin are clocked into an internal shift register on the rising edge of SCLK. Data in the shift register is then transferred on the rising edge of SENB into the internal data register addressed in the address field. The serial interface is disabled when SENB is high.

Table 12 on page 21 summarizes the data register functions and addresses. The internal shift register will ignore any leading bits before the 22 required bits.

## Setting the VCO Center Frequencies

The PLLs can adjust the IF and RF output frequencies  $\pm 5\%$  of the center frequencies of their VCOs. Each center frequency is established by the value of an external inductance connected to the respective VCO. Manufacturing tolerances of  $\pm 10\%$  for the external inductances are acceptable. The Si4133 will compensate for inaccuracies in each inductance by executing a self-tuning algorithm following PLL power-up or following a change in the programmed output frequency.

Because the total tank inductance is in the low nH range, the inductance of the package needs to be considered in determining the correct external inductance. The total inductance ( $L_{TOT}$ ) presented to each VCO is the sum of the external inductance ( $L_{EXT}$ ) and the package inductance ( $L_{PKG}$ ). Each VCO has a nominal capacitance ( $C_{NOM}$ ) in parallel with the total inductance, and the center frequency is as follows:



$$f_{\text{CEN}} = \frac{1}{2\pi\sqrt{L_{\text{TOT}} \cdot C_{\text{NOM}}}}$$

or

$$f_{\text{CEN}} = \frac{1}{2\pi\sqrt{(L_{\text{PKG}} + L_{\text{EXT}}) \cdot C_{\text{NOM}}}}$$

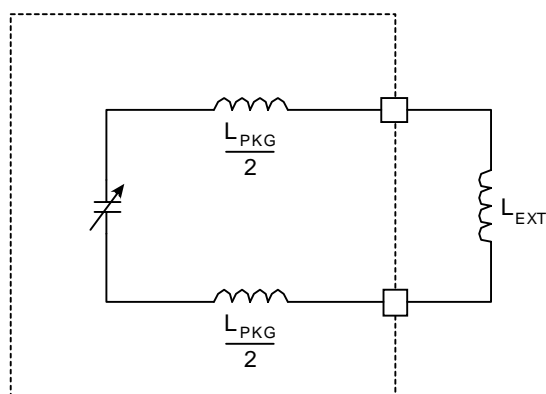
Tables 6 and 7 summarize the characteristics of each VCO.

**Table 6. Si4133-BT VCO Characteristics**

VCO	f <sub>CEN</sub> Range (MHz)		C <sub>NOM</sub> (pF)	L <sub>PKG</sub> (nH)	L <sub>EXT</sub> Range (nH)	
	Min	Max			Min	Max
RF1	947	1720	4.3	2.0	0.0	4.6
RF2	789	1429	4.8	2.3	0.3	6.2
IF	526	952	6.5	2.1	2.2	12.0

**Table 7. Si4133-BM VCO Characteristics**

VCO	f <sub>CEN</sub> Range (MHz)		C <sub>NOM</sub> (pF)	L <sub>PKG</sub> (nH)	L <sub>EXT</sub> Range (nH)	
	Min	Max			Min	Max
RF1	947	1720	4.3	1.5	0.5	5.1
RF2	789	1429	4.8	1.5	1.1	7.0
IF	526	952	6.5	1.6	2.7	12.5



**Figure 15. External Inductance Connection**

As a design example, suppose the goal is to synthesize frequencies in a 25 MHz band between 1120 MHz and

1145 MHz. The center frequency should be defined as midway between the two extremes, or 1132.5 MHz. The PLL will be able to adjust the VCO output frequency  $\pm 5\%$  of the center frequency, or  $\pm 56.6$  MHz of 1132.5 MHz (i.e., from approximately 1076 MHz to 1189 MHz). The RF2 VCO has a C<sub>NOM</sub> of 4.8 pF. A 4.1 nH inductance (correct to two digits) in parallel with this capacitance will yield the desired center frequency. An external inductance of 1.8 nH should be connected between RFLC and RFLD as shown in Figure 15. This, in addition to 2.3 nH of package inductance, will present the correct total inductance to the VCO. In manufacturing, the external inductance can vary  $\pm 10\%$  of its nominal value and the Si4133 will correct for the variation with the self-tuning algorithm.

For more information on designing the external trace inductors, refer to Application Note 31.

## Extended Frequency Operation

The Si4133 may operate at an extended frequency range of 1850 MHz to 2050 MHz by connecting the RFLA and RFLB pins directly. For information on configuring the Si4133 for extended frequency operation, refer to Application Note 41.

## Self-Tuning Algorithm

The self-tuning algorithm is initiated immediately following power-up of a PLL or, if the PLL is already powered, following a change in its programmed output frequency. This algorithm attempts to tune the VCO so that its free-running frequency is near the desired output frequency. In doing so, the algorithm will compensate for manufacturing tolerance errors in the value of the external inductance connected to the VCO. It will also reduce the frequency error for which the PLL must correct to get the precise desired output frequency. The self-tuning algorithm will leave the VCO oscillating at a frequency in error by somewhat less than 1% of the desired output frequency.

After self-tuning, the PLL controls the VCO oscillation frequency. The PLL will complete frequency locking, eliminating any remaining frequency error. Thereafter, it will maintain frequency-lock, compensating for effects caused by temperature and supply voltage variations.

The Si4133's self-tuning algorithm will compensate for component value errors at any temperature within the specified temperature range. However, the ability of the PLL to compensate for drift in component values that occur after self-tuning is limited. For external inductances with temperature coefficients around  $\pm 150$  ppm/ $^{\circ}\text{C}$ , the PLL will be able to maintain lock for changes in temperature of approximately  $\pm 30$   $^{\circ}\text{C}$ .

Applications where the PLL is regularly powered-down or the frequency is periodically reprogrammed minimize or eliminate the potential effects of temperature drift because the VCO is re-tuned in either case. In applications where the ambient temperature can drift substantially after self-tuning, it may be necessary to monitor the lock-detect bar (LDET<sub>B</sub>) signal on the AUXOUT pin to determine whether a PLL is about to run out of locking capability. (See “Auxiliary Output (AUXOUT)” for how to select LDET<sub>B</sub>.) The LDET<sub>B</sub> signal will be low after self-tuning has completed but will rise when either the IF or RF PLL nears the limit of its compensation range. (LDET<sub>B</sub> will also be high when either PLL is executing the self-tuning algorithm.) The output frequency will still be locked when LDET<sub>B</sub> goes high, but the PLL will eventually lose lock if the temperature continues to drift in the same direction. Therefore, if LDET<sub>B</sub> goes high both the IF and RF PLLs should promptly be re-tuned by initiating the self-tuning algorithm.

## Output Frequencies

The IF and RF output frequencies are set by programming the R- and N-Divider registers. Each PLL has its own R and N registers so that each can be programmed independently. Programming either the R- or N-Divider register for RF1 or RF2 automatically selects the associated output.

The reference frequency on the XIN pin is divided by R and this signal is input to the PLL’s phase detector. The other input to the phase detector is the PLL’s VCO output frequency divided by N. The PLL acts to make these frequencies equal. That is, after an initial transient

$$\frac{f_{OUT}}{N} = \frac{f_{REF}}{R}$$

or

$$f_{OUT} = \frac{N}{R} \cdot f_{REF}$$

The R values are set by programming the RF1 R-Divider register (Register 6), the RF2 R-Divider register (Register 7) and the IF R-Divider register (Register 8).

The N values are set by programming the RF1 N-Divider register (Register 3), the RF2 N-Divider register (Register 4), and the IF N-Divider register (Register 5).

Each N-Divider is implemented as a conventional high speed divider. That is, it consists of a dual-modulus prescaler, a swallow counter, and a lower speed synchronous counter. However, the control of these sub-circuits is handled automatically. Only the appropriate N value should be programmed.

## PLL Loop Dynamics

The transient response for each PLL is determined by its phase detector update rate  $f_\phi$  (equal to  $f_{REF}/R$ ) and the phase detector gain programmed for each RF1, RF2, or IF synthesizer. (See Register 1.) Four different settings for the phase detector gain are available for each PLL. The highest gain is programmed by setting the two phase detector gain bits to 00, and the lowest by setting the bits to 11. The values of the available gains, relative to the highest gain, are as follows:

**Table 8. Gain Values (Register 1)**

K <sub>P</sub> Bits	Relative P.D. Gain
00	1
01	1/2
10	1/4
11	1/8

The gain value bits can be automatically set by setting the Auto K<sub>P</sub> bit (bit 2) in the Main Configuration register to 1. In setting this bit, the gain values will be optimized for a given value of N. In general, a higher phase detector gain will decrease in-band phase noise and increase the speed of the PLL transient until the point at which stability begins to be compromised. The optimal gain depends on N. Table 9 lists recommended settings for different values of N. These are the settings used when the Auto K<sub>P</sub> bit is set.

**Table 9. Optimal K<sub>P</sub> Settings**

N	RF1 K <sub>P1</sub> <1:0>	RF2 K <sub>P2</sub> <3:2>	IF K <sub>P1</sub> <5:4>
≤2047	00	00	00
2048 to 4095	00	00	01
4096 to 8191	00	01	10
8192 to 16383	01	10	11
16384 to 32767	10	11	11
≥32768	11	11	11

The VCO gain and loop filter characteristics are not programmable.

The settling time for the PLL is directly proportional to its phase detector update period  $T_\phi$  ( $T_\phi$  equals  $1/f_\phi$ ). A typical transient response is shown in Figure 6 on page 11. During the first 13 update periods the Si4133 executes the self-tuning algorithm. Thereafter the PLL

controls the output frequency. Because of the unique architecture of the Si4133 PLLs, the time required to settle the output frequency to 0.1 ppm error is only about 25 update periods. Thus, the total time after power-up or a change in programmed frequency until the synthesized frequency is well settled—including time for self-tuning—is around 40 update periods.

**Note:** The settling time analysis holds for RF1  $f_{\phi} \leq 500$  kHz.

For RF1  $f_{\phi} > 500$  kHz, the settling time is larger.

## RF and IF Outputs

The RFOUT and IFOUT pins are driven by amplifiers that buffer the RF VCOs and IF VCO, respectively. The RF output amplifier receives its input from either the RF1 or RF2 VCO, depending upon which R- or N-Divider register was last written. For example, programming the N-Divider register for RF1 automatically selects the RF1 VCO output.

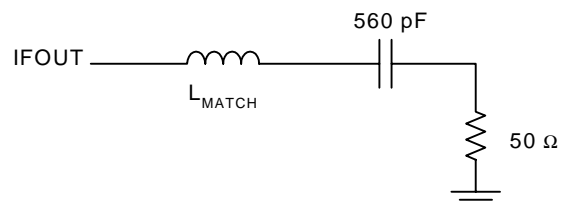
Figures 13 and 14 show application diagrams for the Si4133. The RF output signal must be AC coupled to its load through a capacitor. An external inductance between the RFOUT pin and the AC coupling capacitor is required as part of an output matching network to maximize power delivered to the load. This 2 nH inductance may be realized with a PC board trace. The network is made to provide an adequate match to an external 50  $\Omega$  load for both the RF1 and RF2 frequency bands. The matching network also filters the output signal to reduce harmonic distortion.

The IFOUT pin must also be AC coupled to its load through a capacitor. The IF output level is dependent upon the load. Figure 18 on page 20 displays the output level versus load resistance for a variety of output frequencies. For resistive loads greater than 500  $\Omega$  the output level saturates and the bias currents in the IF output amplifier are higher than they need to be. The LPWR bit in the Main Configuration register (Register 0) can be set to 1 to reduce the bias currents and therefore reduce the power dissipated by the IF amplifier. For loads less than 500  $\Omega$ , LPWR should be set to 0 to maximize the output level.

For IF frequencies greater than 500 MHz, a matching network is required in order to drive a 50  $\Omega$  load. See Figure 16 below. The value of  $L_{MATCH}$  can be determined from Table 10.

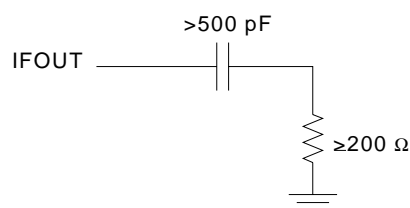
**Table 10.  $L_{MATCH}$  Values**

Frequency	$L_{MATCH}$
500–600 MHz	40 nH
600–800 MHz	27 nH
800 MHz–1 GHz	18 nH



**Figure 16. IF Frequencies > 500 MHz**

For frequencies less than 500 MHz, the IF output buffer can directly drive a 200  $\Omega$  resistive load or higher. For resistive loads greater than 500  $\Omega$  ( $f < 500$  MHz) the LPWR bit can be set to reduce the power consumed by the IF output buffer. See Figure 17 below.



**Figure 17. IF Frequencies < 500 MHz**

## Reference Frequency Amplifier

The Si4133 provides a reference frequency amplifier. If the driving signal has CMOS levels it can be connected directly to the XIN pin. Otherwise, the reference frequency signal should be AC coupled to the XIN pin through a 560 pF capacitor.

## Power Down Modes

Table 11 summarizes the power down functionality. The Si4133 can be powered down by taking the PWDNB pin low or by setting bits in the Power Down register (Register 2). When the PWDNB pin is low, the Si4133 will be powered down regardless of the Power Down register settings. When the PWDNB pin is high, power management is under control of the Power Down register bits.

The IF and RF sections of the Si4133 circuitry can be individually powered down by setting the Power Down register bits PDIB and PDRB low, respectively. Note that the reference frequency amplifier will also be powered up if either the PDRB and PDIB bits are high. Also, setting the AUTOPDB bit to 1 in the Main Configuration register (Register 0) is equivalent to setting both bits in the Power Down register to 1.

The serial interface remains available and can be written in all power down modes.



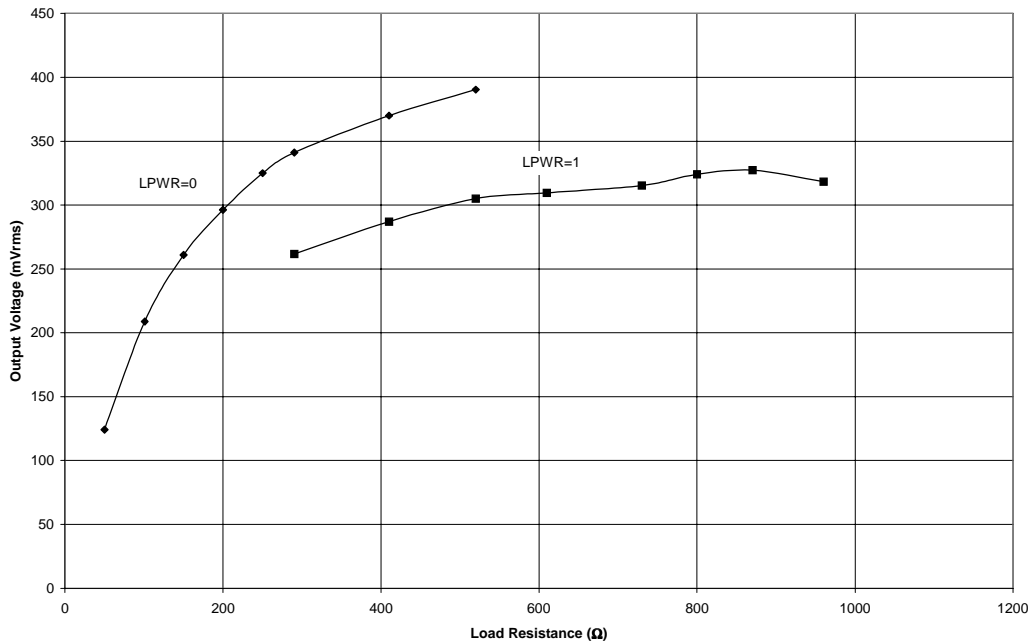
## Auxiliary Output (AUXOUT)

The signal appearing on AUXOUT is selected by setting the AUXSEL bits in the Main Configuration register (Register 0).

The LDET signal can be selected by setting the AUXSEL bits to 11. This signal can be used to indicate that the IF or RF PLL is about to lose lock due to excessive ambient temperature drift and should be re-tuned.

**Table 11. Power Down Configuration**

PWDNB Pin	AUTOPDB	PDIB	PDRB	IF Circuitry	RF Circuitry
PWDNB = 0	X	X	X	OFF	OFF
PWDNB = 1	0	0	0	OFF	OFF
	0	0	1	OFF	ON
	0	1	0	ON	OFF
	0	1	1	ON	ON
	1	x	x	ON	ON



**Figure 18. Typical IF Output Voltage vs. Load Resistance at 550 MHz**

## Control Registers

Table 12. Register Summary

Register	Name	Bit 17	Bit 16	Bit 15	Bit 14	Bit 13	Bit 12	Bit 11	Bit 10	Bit 9	Bit 8	Bit 7	Bit 6	Bit 5	Bit 4	Bit 3	Bit 2	Bit 1	Bit 0	
0	Main Configuration	0	0	0	0	AUXSEL [1:0]		IFDIV [1:0]		0	0	0	0	LPWR	0	AUTO PDB	AUTO K <sub>P</sub>	RF PWR	0	
1	Phase Detector Gain	0	0	0	0	0	0	0	0	0	0	0	0	K <sub>P1</sub> [1:0]		K <sub>P2</sub> [1:0]		K <sub>P1</sub> [1:0]		
2	Power Down	0	0	0	0	0	0	0	0	0	0	0	0	0	0	0	0	0	PDIB	PDRB
3	RF1 N-Divider	N <sub>RF1</sub> [17:0]																		
4	RF2 N-Divider	0	N <sub>RF2</sub> [16:0]																	
5	IF N-Divider	0	0	N <sub>IF</sub> [15:0]																
6	RF1 R-Divider	0	0	0	0	0	R <sub>RF1</sub> [12:0]													
7	RF2 R-Divider	0	0	0	0	0	R <sub>RF2</sub> [12:0]													
8	IF R-Divider	0	0	0	0	0	R <sub>IF</sub> [12:0]													
9	Reserved																			
.																				
.																				
.																				
15	Reserved																			

**Note:** Registers 9–15 are reserved. Writes to these registers may result in unpredictable behavior. Any register not listed here is reserved and should not be written.



## Register 0. Main Configuration Address Field = A[3:0] = 0000

Bit	D17	D16	D15	D14	D13	D12	D11	D10	D9	D8	D7	D6	D5	D4	D3	D2	D1	D0
Name	0	0	0	0	AUXSEL [1:0]	IFDIV [1:0]	0	0	0	0	0	0	LPWR	0	AUTO PDB	AUTO K <sub>p</sub>	RF PWR	0

Bit	Name	Function
17:14	Reserved	Program to zero.
13:12	AUXSEL[1:0]	<b>Auxiliary Output Pin Definition.</b> 00 = Reserved. 01 = Force output low. 10 = Reserved. 11 = Lock Detect—LDET <sub>B</sub> .
11:10	IFDIV[1:0]	<b>IF Output Divider.</b> 00 = IFOUT = IFVCO Frequency 01 = IFOUT = IFVCO Frequency/2 10 = IFOUT = IFVCO Frequency/4 11 = IFOUT = IFVCO Frequency/8
9:6	Reserved	Program to zero.
5	LPWR	<b>Output Power-Level Settings for IF Synthesizer Circuit.</b> 0 = R <sub>LOAD</sub> < 500 Ω—normal power mode. 1 = R <sub>LOAD</sub> ≥ 500 Ω—low power mode.
4	Reserved	Program to zero.
3	AUTOPDB	<b>Auto Power Down.</b> 0 = Software powerdown is controlled by Register 2. 1 = Equivalent to setting all bits in Register 2 = 1.
2	AUTOK <sub>p</sub>	<b>Auto K<sub>p</sub> Setting.</b> 0 = K <sub>p</sub> s are controlled by Register 1. 1 = K <sub>p</sub> s are set according to Table 9 on page 18.
1	RFPWR	Program to zero. (Used for extended frequency operation. See AN41 for more information.)
0	Reserved	Program to zero.

**Register 1. Phase Detector Gain** Address Field (A[3:0]) = 0001

Bit	D17	D16	D15	D14	D13	D12	D11	D10	D9	D8	D7	D6	D5	D4	D3	D2	D1	D0
Name	0	0	0	0	0	0	0	0	0	0	0	0	K <sub>P1</sub> [1:0]		K <sub>P2</sub> [1:0]		K <sub>P1</sub> [1:0]	

Bit	Name	Function
17:6	Reserved	Program to zero.
5:4	K <sub>P1</sub> [1:0]	<b>IF Phase Detector Gain Constant.*</b> N Value      K <sub>P1</sub> <2048        = 00 2048–4095   = 01 4096–8191   = 10 >8191        = 11
3:2	K <sub>P2</sub> [1:0]	<b>RF2 Phase Detector Gain Constant.*</b> N Value      K <sub>P2</sub> <4096        = 00 4096–8191   = 01 8192–16383   = 10 >16383       = 11
1:0	K <sub>P1</sub> [1:0]	<b>RF1 Phase Detector Gain Constant.*</b> N Value      K <sub>P1</sub> <8192        = 00 8192–16383   = 01 16384–32767 = 10 >32767       = 11

**\*Note:** When AUTOK<sub>P</sub> = 1, these bits do not need to be programmed. When AUTOK<sub>P</sub> = 0, use these recommended values for programming Phase Detector Gain.



## Register 2. Power Down Address Field (A[3:0]) = 0010

Bit	D17	D16	D15	D14	D13	D12	D11	D10	D9	D8	D7	D6	D5	D4	D3	D2	D1	D0
Name	0	0	0	0	0	0	0	0	0	0	0	0	0	0	0	0	PDIB	PDRB

Bit	Name	Function
17:2	Reserved	Program to 0.
1	PDIB	<b>Power Down IF Synthesizer.</b> 0 = IF synthesizer powered down. 1 = IF synthesizer on.
0	PDRB	<b>Power Down RF Synthesizer.</b> 0 = RF synthesizer powered down. 1 = RF synthesizer on.

**Note:** Enabling any PLL with PDIB or PDRB will automatically power on the reference amplifier.

## Register 3. RF1 N-Divider Address Field (A[3:0]) = 0011

Bit	D17	D16	D15	D14	D13	D12	D11	D10	D9	D8	D7	D6	D5	D4	D3	D2	D1	D0
Name	N <sub>RF1</sub> [17:0]																	

Bit	Name	Function
17:0	N <sub>RF1</sub> [17:0]	<b>N-Divider for RF1 Synthesizer.</b>

## Register 4. RF2 N-Divider Address Field = A[3:0] = 0100

Bit	D17	D16	D15	D14	D13	D12	D11	D10	D9	D8	D7	D6	D5	D4	D3	D2	D1	D0
Name	0	N <sub>RF2</sub> [16:0]																

Bit	Name	Function
17	Reserved	Program to 0.
16:0	N <sub>RF2</sub> [16:0]	<b>N-Divider for RF2 Synthesizer.</b>



**Register 5. IF N-Divider Address Field (A[3:0]) = 0101**

Bit	D17	D16	D15	D14	D13	D12	D11	D10	D9	D8	D7	D6	D5	D4	D3	D2	D1	D0
Name	0	0	N <sub>IF</sub> [15:0]															

Bit	Name	Function
17:16	Reserved	Program to zero.
15:0	N <sub>IF</sub> [15:0]	<b>N-Divider for IF Synthesizer.</b>

**Register 6. RF1 R-Divider Address Field (A[3:0]) = 0110**

Bit	D17	D16	D15	D14	D13	D12	D11	D10	D9	D8	D7	D6	D5	D4	D3	D2	D1	D0
Name	0	0	0	0	0	R <sub>RF1</sub> [12:0]												

Bit	Name	Function
17:13	Reserved	Program to zero.
12:0	R <sub>RF1</sub> [12:0]	<b>R-Divider for RF1 Synthesizer.</b> R <sub>RF1</sub> can be any value from 7 to 8189 if K <sub>P1</sub> = 00 8 to 8189 if K <sub>P1</sub> = 01 10 to 8189 if K <sub>P1</sub> = 10 14 to 8189 if K <sub>P1</sub> = 11

**Register 7. RF2 R-Divider Address Field (A[3:0]) = 0111**

Bit	D17	D16	D15	D14	D13	D12	D11	D10	D9	D8	D7	D6	D5	D4	D3	D2	D1	D0
Name	0	0	0	0	0	R <sub>RF2</sub> [12:0]												

Bit	Name	Function
17:13	Reserved	Program to zero.
12:0	R <sub>RF2</sub> [12:0]	<b>R-Divider for RF2 Synthesizer.</b> R <sub>RF2</sub> can be any value from 7 to 8189 if K <sub>P2</sub> = 00 8 to 8189 if K <sub>P2</sub> = 01 10 to 8189 if K <sub>P2</sub> = 10 14 to 8189 if K <sub>P2</sub> = 11

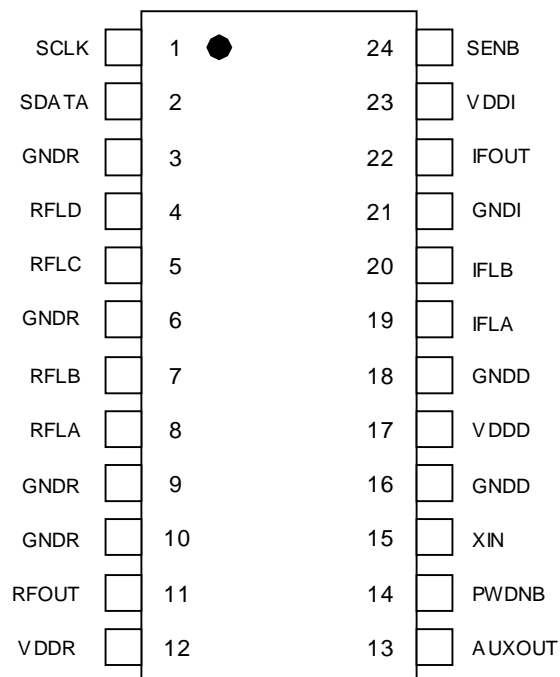


**Register 8. IF R-Divider Address Field (A[3:0]) = 1000**

Bit	D17	D16	D15	D14	D13	D12	D11	D10	D9	D8	D7	D6	D5	D4	D3	D2	D1	D0
Name	0	0	0	0	0	R <sub>IF</sub> [12:0]												

Bit	Name	Function
17:13	Reserved	Program to zero.
12:0	R <sub>IF</sub> [12:0]	<b>R-Divider for IF Synthesizer.</b> R <sub>IF</sub> can be any value from <ul style="list-style-type: none"> <li>7 to 8189 if K<sub>P1</sub> = 00</li> <li>8 to 8189 if K<sub>P1</sub> = 01</li> <li>10 to 8189 if K<sub>P1</sub> = 10</li> <li>14 to 8189 if K<sub>P1</sub> = 11</li> </ul>

## Pin Descriptions: Si4133-BT

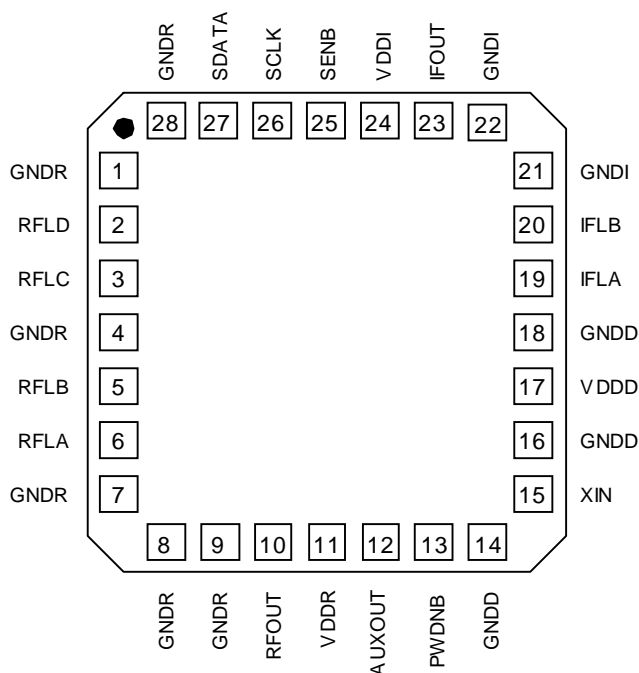


Pin Number(s)	Name	Description
1	SCLK	Serial clock input
2	SDATA	Serial data input
3, 6, 9, 10	GNDR	Common ground for RF analog circuitry
4, 5	RFLC, RFLD	Pins for inductor connection to RF2 VCO
7, 8	RFLA, RFLB	Pins for inductor connection to RF1 VCO
11	RFOUT	Radio frequency (RF) output of the selected RF VCO
12	VDDR	Supply voltage for the RF analog circuitry
13	AUXOUT	Auxiliary output
14	PWDNB	Power down input pin
15	XIN	Reference frequency amplifier input
16, 18	GNDD	Common ground for digital circuitry
17	VDDD	Supply voltage for digital circuitry
19, 20	IFLA, IFLB	Pins for inductor connection to IF VCO
21	GNDI	Common ground for IF analog circuitry
22	IFOUT	Intermediate frequency (IF) output of the IF VCO
23	VDDI	Supply voltage for IF analog circuitry
24	SENB	Enable serial port input

**Table 13. Pin Descriptions for Si4133 Derivatives—TSSOP**

Pin Number	Si4133	Si4123	Si4122	Si4113	Si4112
1	SCLK	SCLK	SCLK	SCLK	SCLK
2	SDATA	SDATA	SDATA	SDATA	SDATA
3	GNDR	GNDR	GNDR	GNDR	GNDD
4	RFLD	GNDR	RFLD	RFLD	GNDD
5	RFLC	GNDR	RFLC	RFLC	GNDD
6	GNDR	GNDR	GNDR	GNDR	GNDD
7	RFLB	RFLB	GNDR	RFLB	GNDD
8	RFLA	RFLA	GNDR	RFLA	GNDD
9	GNDR	GNDR	GNDR	GNDR	GNDD
10	GNDR	GNDR	GNDR	GNDR	GNDD
11	RFOUT	RFOUT	RFOUT	RFOUT	GNDD
12	VDDR	VDDR	VDDR	VDDR	VDDD
13	AUXOUT	AUXOUT	AUXOUT	AUXOUT	AUXOUT
14	PWDNB	PWDNB	PWDNB	PWDNB	PWDNB
15	XIN	XIN	XIN	XIN	XIN
16	GNDD	GNDD	GNDD	GNDD	GNDD
17	VDDD	VDDD	VDDD	VDDD	VDDD
18	GNDD	GNDD	GNDD	GNDD	GNDD
19	IFLA	IFLA	IFLA	GNDD	IFLA
20	IFLB	IFLB	IFLB	GNDD	IFLB
21	GNDI	GNDI	GNDI	GNDD	GNDI
22	IFOUT	IFOUT	IFOUT	GNDD	IFOUT
23	VDDI	VDDI	VDDI	VDDD	VDDI
24	SENB	SENB	SENB	SENB	SENB

## Pin Descriptions: Si4133-BM



Pin Number(s)	Name	Description
1, 4, 7-9, 28	GNDR	Common ground for RF analog circuitry
2, 3	RFLC, RFLD	Pins for inductor connection to RF2 VCO
5,6	RFLA, RFLB	Pins for inductor connection to RF1 VCO
10	RFOUT	Radio frequency (RF) output of the selected RF VCO
11	VDDR	Supply voltage for the RF analog circuitry
12	AUXOUT	Auxiliary output
13	PWDNB	Power down input pin
14, 16, 18	GNDD	Common ground for digital circuitry
15	XIN	Reference frequency amplifier input
17	VDDD	Supply voltage for digital circuitry
19, 20	IFLA, IFLB	Pins for inductor connection to IF VCO
21, 22	GNDI	Common ground for IF analog circuitry
23	IFOUT	Intermediate frequency (IF) output of the IF VCO
24	VDDI	Supply voltage for IF analog circuitry
25	SENB	Enable serial port input
26	SCLK	Serial clock input
27	SDATA	Serial data input



Table 14. Pin Descriptions for Si4133 Derivatives—MLP

Pin Number	Si4133	Si4123	Si4122	Si4113	Si4112
1	GNDR	GNDR	GNDR	GNDR	GNDD
2	RFLD	GNDR	RFLD	RFLD	GNDD
3	RFLC	GNDR	RFLC	RFLC	GNDD
4	GNDR	GNDR	GNDR	GNDR	GNDD
5	RFLB	RFLB	GNDR	RFLB	GNDD
6	RFLA	RFLA	GNDR	RFLA	GNDD
7	GNDR	GNDR	GNDR	GNDR	GNDD
8	GNDR	GNDR	GNDR	GNDR	GNDD
9	GNDR	GNDR	GNDR	GNDR	GNDD
10	RFOUT	RFOUT	RFOUT	RFOUT	GNDD
11	VDDR	VDDR	VDDR	VDDR	VDDD
12	AUXOUT	AUXOUT	AUXOUT	AUXOUT	AUXOUT
13	PWDNB	PWDNB	PWDNB	PWDNB	PWDNB
14	GNDD	GNDD	GNDD	GNDD	GNDD
15	XIN	XIN	XIN	XIN	XIN
16	GNDD	GNDD	GNDD	GNDD	GNDD
17	VDDD	VDDD	VDDD	VDDD	VDDD
18	GNDD	GNDD	GNDD	GNDD	GNDD
19	IFLA	IFLA	IFLA	GNDD	IFLA
20	IFLB	IFLB	IFLB	GNDD	IFLB
21	GNDI	GNDI	GNDI	GNDD	GNDI
22	GNDI	GNDI	GNDI	GNDD	GNDI
23	IFOUT	IFOUT	IFOUT	GNDD	IFOUT
24	VDDI	VDDI	VDDI	VDDD	VDDI
25	SENB	SENB	SENB	SENB	SENB
26	SCLK	SCLK	SCLK	SCLK	SCLK
27	SDATA	SDATA	SDATA	SDATA	SDATA
28	GNDR	GNDR	GNDR	GNDR	GNDD

## Ordering Guide

Ordering Part Number	Description	Operating Temperature
Si4133-BM	RF1/RF2/IF OUT	-40 to 85°C
Si4133-BT	RF1/RF2/IF OUT	-40 to 85°C
Si4123-BM	RF1/IF OUT	-40 to 85°C
Si4123-BT	RF1/IF OUT	-40 to 85°C
Si4122-BM	RF2/IF OUT	-40 to 85°C
Si4122-BT	RF2/IF OUT	-40 to 85°C
Si4113-BM	RF1 OUT	-40 to 85°C
Si4113-BT	RF1 OUT	-40 to 85°C
Si4112-BM	IF OUT	-40 to 85°C
Si4112-BT	IF OUT	-40 to 85°C

## Si4133 Derivative Devices

The Si4133 performs both IF and dual-band RF frequency synthesis. The Si4112, Si4113, Si4122, and the Si4123 are derivatives of this device. Table 15 outlines which synthesizers each derivative device features as well as which pins and registers coincide with each synthesizer.

**Table 15. Si4133 Derivatives**

Name	Synthesizer	Pins	Registers
Si4112	IF	IFLA, IFLB	$N_{IF}$ , $R_{IF}$ , PDIB, IFDIV, LPWR, AUTOPDB = 0, PDRB = 0
Si4113	RF1, RF2	RFLA, RFLB, RFLC, RFLD	$N_{RF1}$ , $N_{RF2}$ , $R_{RF1}$ , $R_{RF2}$ , PDRB, AUTOPDB = 0, PDIB = 0
Si4122	RF2, IF	RFLC, RFLD, IFLA, IFLB	$N_{RF2}$ , $R_{RF2}$ , PDRB, $N_{IF}$ , $R_{IF}$ , PDIB, IFDIV, LPWR
Si4123	RF1, IF	RFLA, RFLB, IFLA, IFLB	$N_{RF1}$ , $R_{RF1}$ , PDRB, $N_{IF}$ , $R_{IF}$ , PDIB, IFDIV, LPWR
Si4133	RF1, RF2, IF	RFLA, RFLB, RFLC, RFLD, IFLA, IFLB	$N_{RF1}$ , $N_{RF2}$ , $R_{RF1}$ , $R_{RF2}$ , PDRB, $N_{IF}$ , $R_{IF}$ , PDIB, IFDIV, LPWR



## Package Outline: Si4133-BT

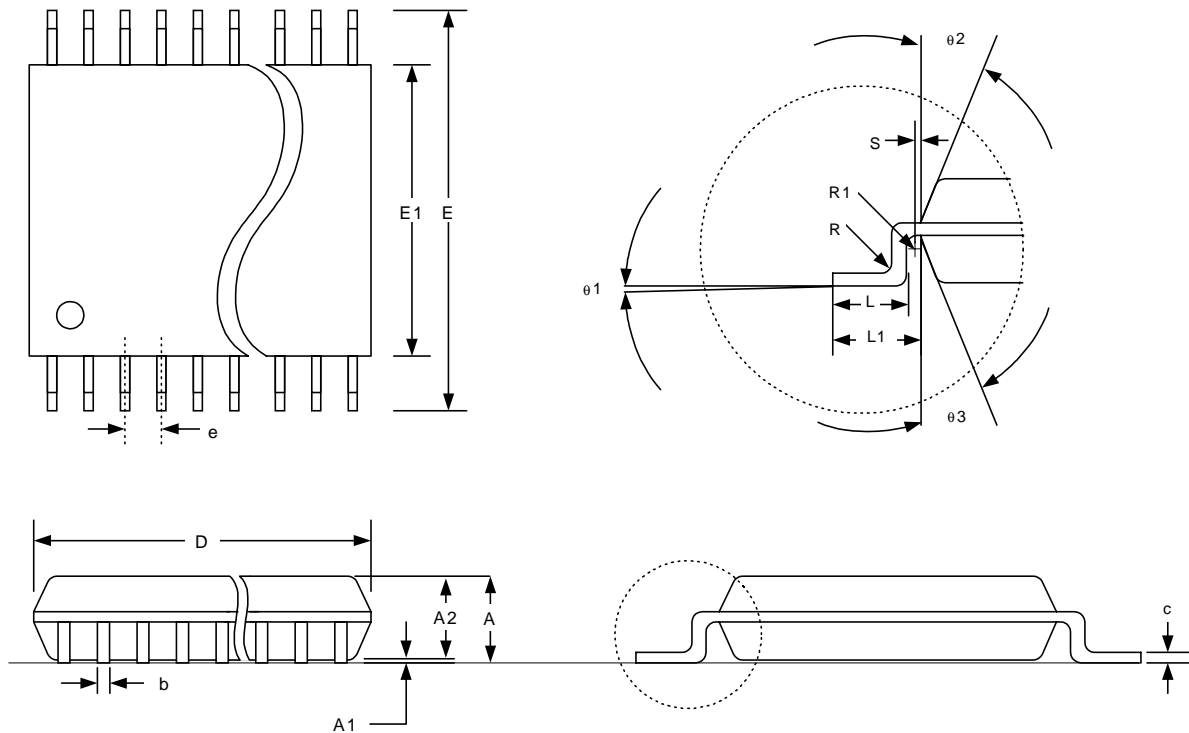


Figure 19. 24-pin Thin Small Shrink Outline Package (TSSOP)

Table 16. Package Diagram Dimensions

Symbol	Millimeters		
	Min	Nom	Max
A	—	1.10	1.20
A1	0.05	—	0.15
A2	0.80	1.00	1.05
b	0.19	—	0.30
c	0.09	—	0.20
D	7.70	7.80	7.90
e	0.65 BSC		
E	6.40 BSC		
E1	4.30	4.40	4.50
L	0.45	0.60	0.75
L1	1.00 REF		
R	0.09	—	—
R1	0.09	—	—
S	0.20	—	—
θ1	0	—	8
θ2	12 REF		
θ3	12 REF		



## Package Outline: Si4133-BM

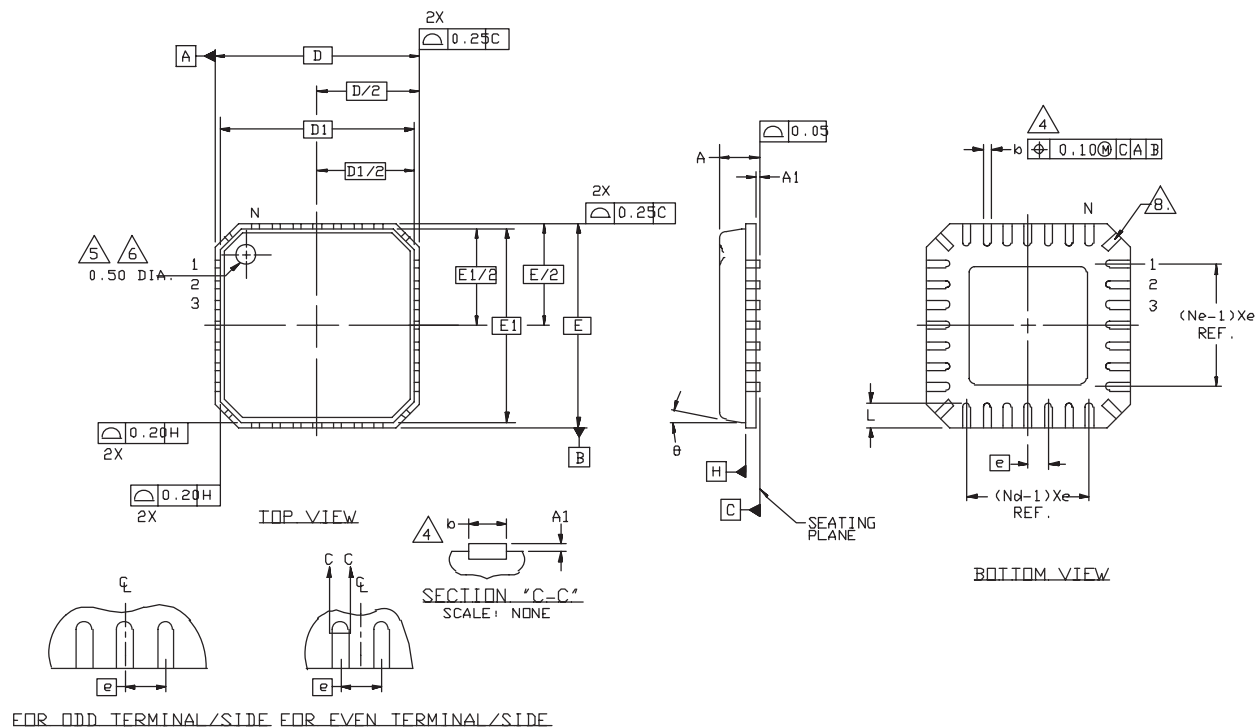


Figure 20. 28-Pin Micro Leadframe Package (MLP)

Table 17. Package Dimensions

Controlling Dimension: mm

Symbol	Millimeters		
	Min	Nom	Max
A	—	0.90	1.00
A1	0.00	0.01	0.05
b	0.18	0.23	0.30
D	5.00 BSC		
D1	4.75 BSC		
E	5.00 BSC		
E1	4.75 BSC		
N	28		
Nd	7		
Ne	7		
e	0.50 BSC		
L	0.50	0.60	0.75
$\theta$			12°

## Contact Information

### Silicon Laboratories Inc.

4635 Boston Lane  
Austin, Texas 78735  
Tel: 1+ (512) 416-8500  
Fax: 1+ (512) 416-9669  
Toll Free: 1+ (877) 444-3032  
Email: [productinfo@silabs.com](mailto:productinfo@silabs.com)  
Internet: [www.silabs.com](http://www.silabs.com)

The information in this document is believed to be accurate in all respects at the time of publication but is subject to change without notice. Silicon Laboratories assumes no responsibility for errors and omissions, and disclaims responsibility for any consequences resulting from the use of information included herein. Additionally, Silicon Laboratories assumes no responsibility for the functioning of undescribed features or parameters. Silicon Laboratories reserves the right to make changes without further notice. Silicon Laboratories makes no warranty, representation or guarantee regarding the suitability of its products for any particular purpose, nor does Silicon Laboratories assume any liability arising out of the application or use of any product or circuit, and specifically disclaims any and all liability, including without limitation consequential or incidental damages. Silicon Laboratories products are not designed, intended, or authorized for use in applications intended to support or sustain life, or for any other application in which the failure of the Silicon Laboratories product could create a situation where personal injury or death may occur. Should Buyer purchase or use Silicon Laboratories products for any such unintended or unauthorized application, Buyer shall indemnify and hold Silicon Laboratories harmless against all claims and damages.

Silicon Laboratories and Silicon Labs are trademarks of Silicon Laboratories Inc.  
Other products or brandnames mentioned herein are trademarks or registered trademarks of their respective holders.