

## General description

VMP3111 is a compact, ultra high efficiency low voltage DC-DC power supply module. It integrated all necessary components in a small (0.7"x0.6"x0.14") package. The internal DC-DC converter can convert 3.6V-5.5V input voltage to 1.0-3.3V, up to 2.0A current. The small size, low profile and high efficiency makes it is the ideal choice for applications which size and energy requirement is critical.

## 1. Applications

- Instruments
- Handheld devices
- Communication equipments
- Battery powered devices
- Home entertainment
- Embedded, DSP, FPGA systems

## 2. Pinout

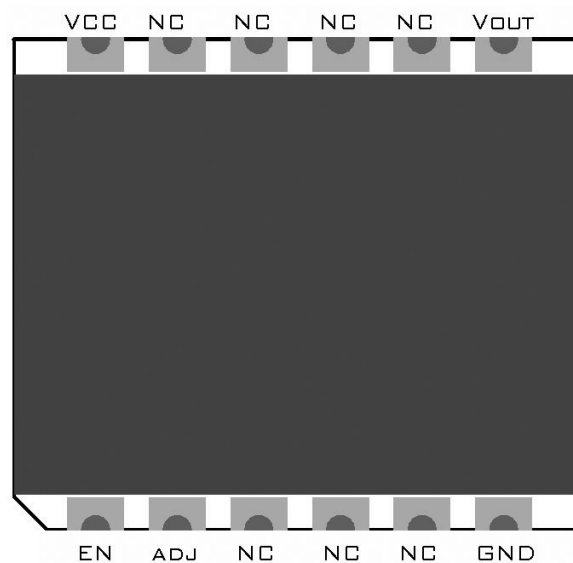

### Pin Description

Pin No.	Name	Function Description
2	ADJ	Output voltage adjustment. Output voltage = 3.3v when Connected to GND. Connect a resistor between GND and ADJ can adjust the output voltage between 1.0V to 3.3V
6	GND	Power Ground
7	Vout	Voltage Output
12	VCC	Power Input (3.6V-5.5V)

## 3. Electrical Characteristics

Parameters	Value
Supply Voltage	3.6V to 5.5V
Output Voltage	1.0V-3.3V adjustable
Output Current	2.0A
Efficiency	95% max
Idle Current	10uA
Vp-p	50mV(full load)

## 4. Reference Design

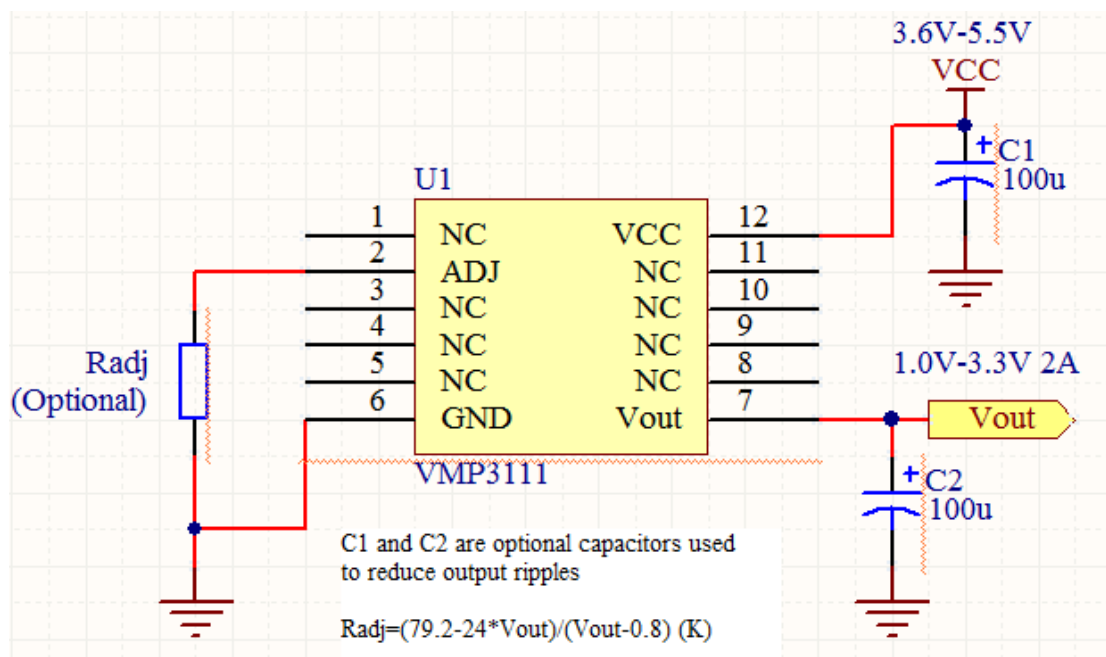

## 5. Set the output voltage

The output voltage is programmed by connecting a resistor between ADJ (pin2) and GND. The value of Radj us calculated by the following formular:

$$R_{adj} = \frac{79.2 - 24 \times V_{out}}{V_{out} - 0.8} \text{ (K}\Omega\text{)}$$

Radj can also be selected from the following table:

Vout (V)	Radj (k)
3.3	0.0
3.0	3.3
2.5	11.3
2.0	26.0
1.8	36.0

1.5	61.7
1.2	126.0
1.0	276.0

## 6. Footprint and dimensions

