

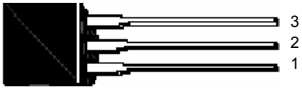

■ QUICK REFERENCE 【參考特性】

產品型號 Part Number	工業型號 Industry Part №	通態電流均方值 $I_{T(RMS)}$ (A)	斷態重復峰值電壓 V_{DRM} / V_{RRM} (V)	門極觸發電流 $I_{GT}(\mu A/mA)$	封裝外形 Package	包裝方式 Packing	元件標識 Marking
PCR206	PCR206	0.6A	200V	$\leq 200\mu A$	TO-92	1Kpcs/Bulk 10Kpcs/Box 100Kpcs/Box TO-92 Tape: 2000pcs/Box 每包1Kpcs 每盒10Kpcs	 元件標識可按客戶指定要求
PCR406	PCR406		400V				
PCR506	PCR506		500V				
PCR606	PCR606		600V				
PCR806	PCR806		800V				
說明 Explain	①此規格型號為高靈敏度-微觸發、單向可控矽 ②以常規電壓規格出貨, 高壓規格機種(特殊品種), 批量交期6~8周 ③門極觸發電流IGT值可根據客戶要求細分至多個規格, 單位 μA (微安)						

■ PINNING: TO-92 (TO-226) or TO-92 Tape & Reel 【TO-92直插封裝 或 TO-92直插編帶封裝】

Pin 管腳排列	Symbol 對應極性	Description 極性名詞	Description 極性含義	Practicality in Pin Arrange 元件實物與管腳排列	Pin Polarity Circuit diagram 腳位與極性 電路符號表示
1	K	Cathode	陰極		1=K 2=G 3=A 
2	G	Gate	門極		
3	A	Anode	陽極		

■ ABSOLUTE RATINGS (Limiting Values) 【額定值參數】

SYMBOL 符號表示	Parameter & Test Conditions 符號含義 及 參數測試條件說明	Value 數值	Unit 單位
$I_{T(RMS)}$	通態電流均方值: On-State RMS Current ($T_c=80^\circ C$) 180° Conduction Angles	0.6	A
I_{TSM}	通態浪湧電流: 1/2周期, 60Hz, 正弦波, 不重複 Peak Non-Repetitive Surge Current (1/2 Cycle, Sine Wave, 60Hz, $T_j=25^\circ C$)	6	
I_{GM}	正向門極最大電流: Forward Peak Gate Current (Pulse Width $\leq 1\mu S$, $T_c=25^\circ C$)	0.6	
i^2t	週期電流平方時間積: Circuit Fusing Consideration ($t=8.3ms$)	0.35	A ² ses
P_{GM}	門極平均峰值功率: Forward Peak Gate Power (Pulse Width $\leq 1\mu S$, $T_c=25^\circ C$)	0.5	W
$P_{G(AV)}$	門極平均散耗功率: Forward Average Gate Power($t=8.3ms$, $T_c=80^\circ C$)	0.05	
V_{DRM} or V_{RRM}	斷態重復峰值電壓: Peak Repetitive Off-State Voltage ($T_j=-40\sim 110^\circ C$, Sine Wave, 50~60Hz; Gate Open) (見參考特性對應說明)	200~800	V
T_j	工作結溫: Operating Junction Temperature Range @ Rate V_{RRM} and V_{DRM}	-40 ~ +110	°C
T_{stg}	貯存溫度: Storage Temperature Range	-40 ~ +150	
T_L	引腳承受焊錫極限溫度: Lead Solder Temperature (1/16, from case, 10 secs max)	260	

■ ELECTRICAL CHARACTERISTICS (Tj=25°C Unless Otherwise Noted) 【電參數】

SYMBOL 符號表示	Parameter & Test Conditions 參數符號含義 及 測試條件說明	Min 最小值	Typ 典型值	Max 最大值	Unit 單位
I_{GT}	門極 觸發電流: $V_D=12V_{DC}$, $R_L=140\Omega$ ($T_c=25^\circ C$)	5	50	200	μA
I_H	維持電流: Holding Current ($I_T=50mA$, $V_D=12V_{DC}$, $R_{GK}=1K\Omega$, $T_c=25^\circ C$)	→	0.5	6	mA
I_L	最大接入電流: Latching Current ($V_D=12V$, $I_{GT}=1mA$, $R_{GK}=1K\Omega$, $T_c=25^\circ C$)	→	0.6	7	
V_{GT}	門極 觸發電壓: $V_D=12V$, $R_L=140\Omega$ ($T_j=25^\circ C$)	→	0.5	0.8	V
V_{TM}	峰值通態電壓: Peak Forward On-State Voltage ($I_{TM}=0.4A$, $t_p=380\mu s$)	→	→	1.7	
dv / dt	斷態臨界電壓上升率: Critical Rate of Rise of Off-State Voltage ($T_j=125^\circ C$)	→	200	→	V/ μs
di / dt	通態臨界電流上升率: Critical Rate of Rise of On-State Current	→	→	50	A/ μs
R_D	通態輸出阻抗: Dynamic resistance slopes Resistance	→	→	1000	m Ω
$R_{th(j-c)}$	熱阻-結到外殼: Thermal Resistance-Junction-to-Case	→	→	50	°C/W
$R_{th(j-a)}$	熱阻-結到環境: Thermal Resistance-Junction-to-Ambient	→	→	400	

TO-92
Tape & Reel
TO-92
成型腳位
編帶封裝
器件尺寸

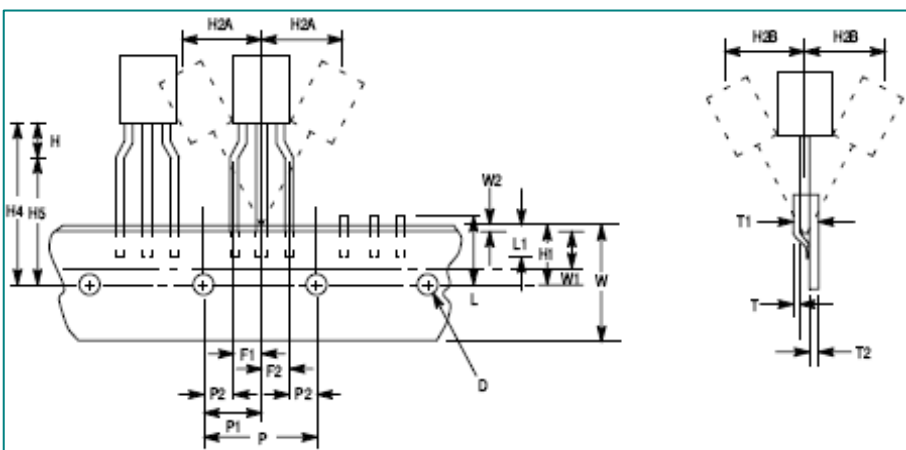
SYMBOL 符號表示	Item 項目詳述	Specification (規格尺寸說明)			
		Inches (英寸單位)		Millimeter (毫米單位)	
		Min (最小)	Max (最大)	Min (最小)	Max (最大)
D	Tape Feedhole Diameter	0.1496	0.1653	3.8	4.2
D2	Component Lead Thickness Dimension	0.015	0.020	0.380	0.510
F1, F2	Component Lead Pitch	0.945	0.11	2.4	2.8
H	Bottom of Component to Seating Plane	0.059	0.156	1.5	4
H1	Feedhole Location	0.3346	0.3741	8.5	9.5
H2A	Deflection Left or Right	0	0.039	0	1
H2B	Deflection Front or Rear	0	0.051	0	1
H4	Feedhole to Bottom of Component	0.7086	0.768	18	19.5
H5	Feedhole to Seating Plane	0.61	0.649	15.5	16.5
L	Defective Unit Clipped Dimension	0.3346	0.433	8.5	11
L1	Lead Wire Enclosure	0.09842	---	2.5	---
P	Feedhole Pitch	0.4921	0.5079	12.5	12.9
P1	Feedhole Center to Center Lead	0.2342	0.2658	5.95	6.75
P2	First Lead Spacing Dimension	0.1397	0.1556	3.55	3.95
T	Adhesive Tape Thickness	0.06	0.08	0.15	0.200
T1	Overall Taped Package Thickness	---	0.0567	---	1.440
T2	Carrier Strip Thickness	0.014	0.027	0.350	0.650
W	Carrier Strip Width	0.6889	0.7481	17.50	19.00
W1	Adhesive Tape Width	0.2165	0.2841	5.50	6.30
W2	Adhesive Tape Position	0.0059	0.01968	0.15	0.50

TO-92
or
TO-226
器件尺寸

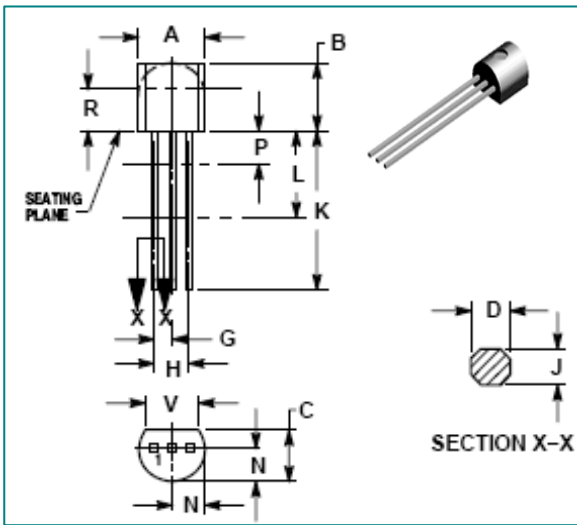

DIM	Specification (規格尺寸說明)			
	Inches (英寸單位)		Millimeter (毫米單位)	
	Min (最小)	Max (最大)	Min (最小)	Max (最大)
A	0.175	0.205	4.450	5.200
B	0.170	0.210	4.320	5.330
C	0.125	0.165	3.180	4.190
D	0.016	0.021	0.407	0.533
G	0.045	0.055	1.150	1.390
H	0.095	0.105	2.420	2.660
J	0.015	0.020	0.390	0.500
K	0.500	-----	12.70	-----
L	0.250	-----	6.350	-----
N	0.080	0.105	2.040	2.660
P	-----	0.100	-----	2.540
R	0.115	-----	2.930	-----
V	0.135	-----	3.430	-----

Fig. 1: Maximum average power dissipation versus average on-state current.

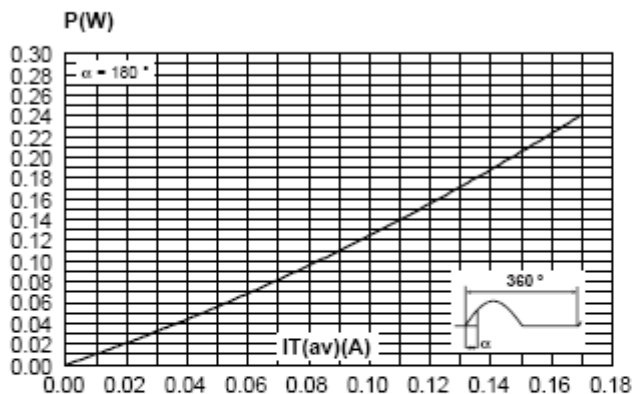

Fig. 3: Relative variation of thermal impedance junction to ambient versus pulse duration.

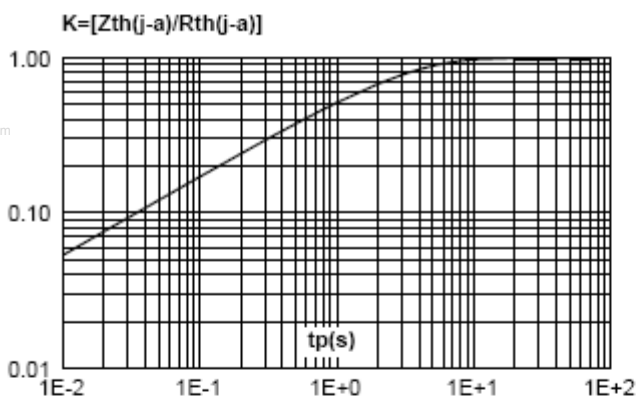

Fig. 5: Relative variation of holding current versus gate-cathode resistance (typical values).

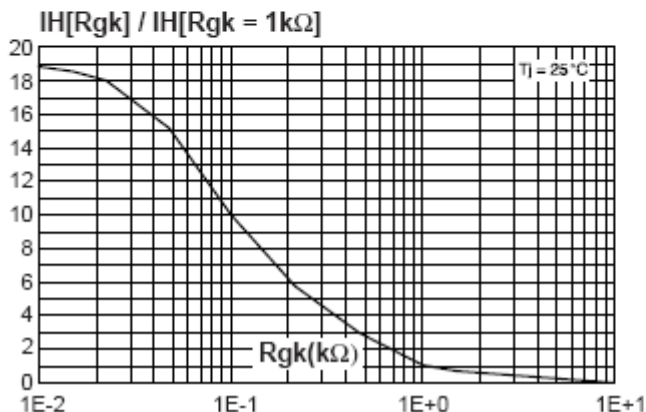

Fig. 2: Average and D.C. on-state current versus ambient temperature.

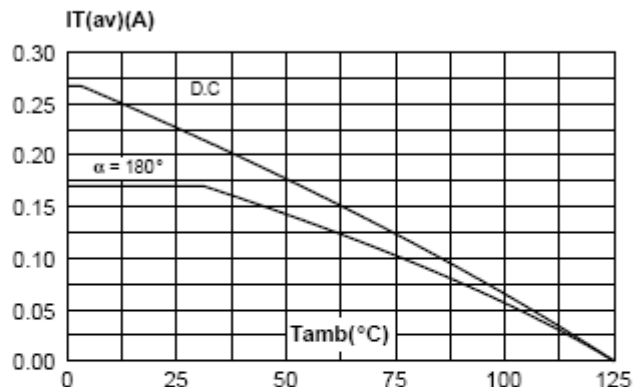

Fig. 4: Relative variation of gate trigger current, holding current and latching current versus junction temperature (typical values).

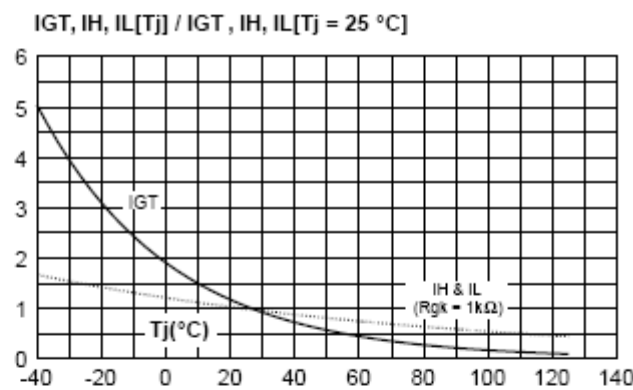

Fig. 6: Relative variation of dV/dt immunity versus gate-cathode resistance (typical values).

