

# SN54LS373, SN54LS374, SN54S373, SN54S374, SN74LS373, SN74LS374, SN74S373, SN74S374

## OCTAL D-TYPE TRANSPARENT LATCHES AND EDGE-TRIGGERED FLIP-FLOPS

SDLS165B – OCTOBER 1975 – REVISED AUGUST 2002

- Choice of Eight Latches or Eight D-Type Flip-Flops in a Single Package
- 3-State Bus-Driving Outputs
- Full Parallel Access for Loading
- Buffered Control Inputs
- Clock-Enable Input Has Hysteresis to Improve Noise Rejection ('S373 and 'S374)
- P-N-P Inputs Reduce DC Loading on Data Lines ('S373 and 'S374)

### description

These 8-bit registers feature 3-state outputs designed specifically for driving highly capacitive or relatively low-impedance loads. The high-impedance 3-state and increased high-logic-level drive provide these registers with the capability of being connected directly to and driving the bus lines in a bus-organized system without need for interface or pullup components. These devices are particularly attractive for implementing buffer registers, I/O ports, bidirectional bus drivers, and working registers.

The eight latches of the 'LS373 and 'S373 are transparent D-type latches, meaning that while the enable (C or CLK) input is high, the Q outputs follow the data (D) inputs. When C or CLK is taken low, the output is latched at the level of the data that was set up.

The eight flip-flops of the 'LS374 and 'S374 are edge-triggered D-type flip-flops. On the positive transition of the clock, the Q outputs are set to the logic states that were set up at the D inputs.

Schmitt-trigger buffered inputs at the enable/clock lines of the 'S373 and 'S374 devices simplify system design as ac and dc noise rejection is improved by typically 400 mV due to the input hysteresis. A buffered output-control ( $\overline{OC}$ ) input can be used to place the eight outputs in either a normal logic state (high or low logic levels) or the high-impedance state. In the high-impedance state, the outputs neither load nor drive the bus lines significantly.

$\overline{OC}$  does not affect the internal operation of the latches or flip-flops. That is, the old data can be retained or new data can be entered, even while the outputs are off.

SN54LS373, SN54LS374, SN54S373,  
SN54S374 . . . J OR W PACKAGE  
SN74LS373, SN74S374 . . . DW, N, OR NS PACKAGE  
SN74LS374 . . . DB, DW, N, OR NS PACKAGE  
SN74S373 . . . DW OR N PACKAGE  
(TOP VIEW)

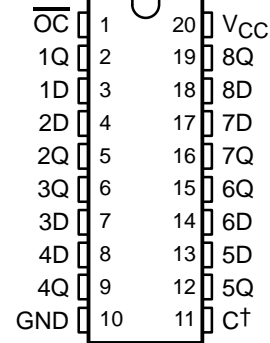

† C for 'LS373 and 'S373; CLK for 'LS374 and 'S374.

SN54LS373, SN54LS374, SN54S373,  
SN54S374 . . . FK PACKAGE  
(TOP VIEW)



† C for 'LS373 and 'S373; CLK for 'LS374 and 'S374.



Please be aware that an important notice concerning availability, standard warranty, and use in critical applications of Texas Instruments semiconductor products and disclaimers thereto appears at the end of this data sheet.

PRODUCTION DATA information is current as of publication date. Products conform to specifications per the terms of Texas Instruments standard warranty. Production processing does not necessarily include testing of all parameters.

**TEXAS  
INSTRUMENTS**

POST OFFICE BOX 655303 • DALLAS, TEXAS 75265

Copyright © 2002, Texas Instruments Incorporated  
On products compliant to MIL-PRF-38535, all parameters are tested unless otherwise noted. On all other products, production processing does not necessarily include testing of all parameters.

**SN54LS373, SN54LS374, SN54S373, SN54S374,  
SN74LS373, SN74LS374, SN74S373, SN74S374  
OCTAL D-TYPE TRANSPARENT LATCHES AND EDGE-TRIGGERED FLIP-FLOPS**

SDLS165B – OCTOBER 1975 – REVISED AUGUST 2002

**ORDERING INFORMATION**

<b>T<sub>A</sub></b>	<b>PACKAGE†</b>		<b>ORDERABLE PART NUMBER</b>	<b>TOP-SIDE MARKING</b>
0°C to 70°C	PDIP – N	Tube	SN74LS373N	SN74LS373N
		Tube	SN74LS374N	SN74LS374N
		Tube	SN74S373N	SN74S373N
		Tube	SN74S374N	SN74S374N
	SOIC – DW	Tube	SN74LS373DW	LS373
		Tape and reel	SN74LS373DWR	
		Tube	SN74LS374DW	LS374
		Tape and reel	SN74LS374DWR	
		Tube	SN74S373DW	S373
		Tape and reel	SN74S373DWR	
		Tube	SN74S374DW	S374
		Tape and reel	SN74S374DWR	
	SOP – NS	Tape and reel	SN74LS373NSR	74LS373
		Tape and reel	SN74LS374NSR	74LS374
		Tape and reel	SN74S374NSR	74S374
	SSOP – DB	Tape and reel	SN74LS374DBR	LS374A
–55°C to 125°C	CDIP – J	Tube	SN54LS373J	SN54LS373J
		Tube	SNJ54LS373J	SNJ54LS373J
		Tube	SN54LS374J	SN54LS374J
		Tube	SNJ54LS374J	SNJ54LS374J
		Tube	SN54S373J	SN54S373J
		Tube	SNJ54S373J	SNJ54S373J
		Tube	SN54S374J	SN54S374J
		Tube	SNJ54S374J	SNJ54S374J
	CFP – W	Tube	SNJ54LS373W	SNJ54LS373W
		Tube	SNJ54LS374W	SNJ54LS374W
		Tube	SNJ54S374W	SNJ54S374W
	LCCC – FK	Tube	SNJ54LS373FK	SNJ54LS373FK
		Tube	SNJ54LS374FK	SNJ54LS374FK
		Tube	SNJ54S373FK	SNJ54S373FK
		Tube	SNJ54S374FK	SNJ54S374FK

† Package drawings, standard packing quantities, thermal data, symbolization, and PCB design guidelines are available at [www.ti.com/sc/package](http://www.ti.com/sc/package).



**SN54LS373, SN54LS374, SN54S373, SN54S374,  
SN74LS373, SN74LS374, SN74S373, SN74S374**  
**OCTAL D-TYPE TRANSPARENT LATCHES AND EDGE-TRIGGERED FLIP-FLOPS**

SDLS165B – OCTOBER 1975 – REVISED AUGUST 2002

**Function Tables**

'LS373, 'S373  
(each latch)

INPUTS			OUTPUT Q
$\overline{OC}$	C	D	
L	H	H	H
L	H	L	L
L	L	X	Q <sub>0</sub>
H	X	X	Z

'LS374, 'S374  
(each latch)

INPUTS			OUTPUT Q
$\overline{OC}$	CLK	D	
L	↑	H	H
L	↑	L	L
L	L	X	Q <sub>0</sub>
H	X	X	Z

**SN54LS373, SN54LS374, SN54S373, SN54S374,  
SN74LS373, SN74LS374, SN74S373, SN74S374**  
**OCTAL D-TYPE TRANSPARENT LATCHES AND EDGE-TRIGGERED FLIP-FLOPS**

SDLS165B – OCTOBER 1975 – REVISED AUGUST 2002

**logic diagrams (positive logic)**



Pin numbers shown are for DB, DW, J, N, NS, and W packages.

**SN54LS373, SN54LS374, SN54S373, SN54S374,  
SN74LS373, SN74LS374, SN74S373, SN74S374**

SDLS165B – OCTOBER 1975 – REVISED AUGUST 2002

**schematic of inputs and outputs**

**'LS373**



**'LS374**



**SN54LS373, SN54LS374, SN54S373, SN54S374,  
SN74LS373, SN74LS374, SN74S373, SN74S374  
OCTAL D-TYPE TRANSPARENT LATCHES AND EDGE-TRIGGERED FLIP-FLOPS**

SDLS165B – OCTOBER 1975 – REVISED AUGUST 2002

**absolute maximum ratings over operating free-air temperature range (unless otherwise noted)†  
(‘LS devices)**

Supply voltage, $V_{CC}$ (see Note 1)	7 V
Input voltage, $V_I$	7 V
Off-state output voltage	5.5 V
Package thermal impedance, $\theta_{JA}$ (see Note 2): DB package	70°C/W
DW package	58°C/W
N package	69°C/W
NS package	60°C/W
Storage temperature range, $T_{stg}$	-65°C to 150°C

† Stresses beyond those listed under “absolute maximum ratings” may cause permanent damage to the device. These are stress ratings only, and functional operation of the device at these or any other conditions beyond those indicated under “recommended operating conditions” is not implied. Exposure to absolute-maximum-rated conditions for extended periods may affect device reliability.

- NOTES: 1. Voltage values are with respect to network ground terminal.  
2. The package thermal impedance is calculated in accordance with JESD 51-7.

**recommended operating conditions**

		SN54LS'			SN74LS'			UNIT		
		MIN	NOM	MAX	MIN	NOM	MAX			
$V_{CC}$	Supply voltage	4.5	5	5	4.75	5	5.25	V		
$V_{OH}$	High-level output voltage			5.5			5.5	V		
$I_{OH}$	High-level output current			-1			-2.6	mA		
$I_{OL}$	Low-level output current			12			24	mA		
$t_w$	Pulse duration	CLK high		15		15		ns		
		CLK low		15		15				
$t_{su}$	Data setup time	'LS373		5↓		5↓		ns		
		'LS374		20↑		20↑				
$t_h$	Data hold time	'LS373		20↓		20↓		ns		
		'LS374‡		5↑		0↑				
$T_A$	Operating free-air temperature			-55		125		0	70	°C

‡ The  $t_h$  specification applies only for data frequency below 10 MHz. Designs above 10 MHz should use a minimum of 5 ns (commercial only).



**SN54LS373, SN54LS374, SN54S373, SN54S374,  
SN74LS373, SN74LS374, SN74S373, SN74S374**  
**OCTAL D-TYPE TRANSPARENT LATCHES AND EDGE-TRIGGERED FLIP-FLOPS**

SDLS165B – OCTOBER 1975 – REVISED AUGUST 2002

**electrical characteristics over recommended operating free-air temperature range (unless otherwise noted)**

PARAMETER	TEST CONDITIONS†	SN54LS'			SN74LS'			UNIT	
		MIN	TYP‡	MAX	MIN	TYP‡	MAX		
V <sub>IH</sub> High-level input voltage		2			2			V	
V <sub>IL</sub> Low-level input voltage					0.7			V	
V <sub>IK</sub> Input clamp voltage	V <sub>CC</sub> = MIN, I <sub>I</sub> = -18 mA				-1.5			V	
V <sub>OH</sub> High-level output voltage	V <sub>CC</sub> = MIN, V <sub>IH</sub> = 2 V, V <sub>IL</sub> = V <sub>IL</sub> max, I <sub>OH</sub> = MAX	2.4	3.4		2.4	3.1		V	
V <sub>OL</sub> Low-level output voltage	V <sub>CC</sub> = MIN, V <sub>IH</sub> = 2 V, V <sub>IL</sub> = V <sub>IL</sub> max	I <sub>OL</sub> = 12 mA			0.25	0.4		V	
		I <sub>OL</sub> = 24 mA					0.35 0.5		
I <sub>OZH</sub> Off-state output current, high-level voltage applied	V <sub>CC</sub> = MAX, V <sub>O</sub> = 2.7 V, V <sub>IH</sub> = 2 V				20			μA	
I <sub>OZL</sub> Off-state output current, low-level voltage applied	V <sub>CC</sub> = MAX, V <sub>O</sub> = 0.4 V, V <sub>IH</sub> = 2 V				-20			μA	
I <sub>I</sub> Input current at maximum input voltage	V <sub>CC</sub> = MAX, V <sub>I</sub> = 7 V				0.1			mA	
I <sub>IH</sub> High-level input current	V <sub>CC</sub> = MAX, V <sub>I</sub> = 2.7 V				20			μA	
I <sub>IL</sub> Low-level input current	V <sub>CC</sub> = MAX, V <sub>I</sub> = 0.4 V				-0.4			mA	
I <sub>OS</sub> Short-circuit output current§	V <sub>CC</sub> = MAX				-30	-130	-30	-130	mA
I <sub>CC</sub> Supply current	V <sub>CC</sub> = MAX, Output control at 4.5 V	'LS373			24	40	24	40	mA
		'LS374			27	40	27	40	

† For conditions shown as MIN or MAX, use the appropriate value specified under recommended operating conditions.

‡ All typical values are at V<sub>CC</sub> = 5 V, T<sub>A</sub> = 25°C.

§ Not more than one output should be shorted at a time and duration of the short circuit should not exceed one second.

**switching characteristics, V<sub>CC</sub> = 5 V, T<sub>A</sub> = 25°C (see Figure 1)**

PARAMETER	FROM (INPUT)	TO (OUTPUT)	TEST CONDITIONS	'LS373			'LS374			UNIT
				MIN	TYP	MAX	MIN	TYP	MAX	
f <sub>max</sub>			R <sub>L</sub> = 667 Ω, C <sub>L</sub> = 45 pF, See Note 3				35	50		MHz
t <sub>PLH</sub>	Data	Any Q	R <sub>L</sub> = 667 Ω, C <sub>L</sub> = 45 pF, See Note 3	12 18						ns
t <sub>PHL</sub>				12 18						
t <sub>PLH</sub>	C or CLK	Any Q	R <sub>L</sub> = 667 Ω, C <sub>L</sub> = 45 pF, See Note 3	20 30			15 28			ns
t <sub>PHL</sub>				18 30			19 28			
t <sub>PZH</sub>	$\overline{OC}$	Any Q	R <sub>L</sub> = 667 Ω, C <sub>L</sub> = 45 pF, See Note 3	15 28			20 26			ns
t <sub>PZL</sub>				25 36			21 28			
t <sub>PHZ</sub>	$\overline{OC}$	Any Q	R <sub>L</sub> = 667 Ω, C <sub>L</sub> = 5 pF	15 25			15 28			ns
t <sub>PLZ</sub>				12 20			12 20			

NOTE 3: Maximum clock frequency is tested with all outputs loaded.

f<sub>max</sub> = maximum clock frequency

t<sub>PLH</sub> = propagation delay time, low-to-high-level output

t<sub>PHL</sub> = propagation delay time, high-to-low-level output

t<sub>PZH</sub> = output enable time to high level

t<sub>PZL</sub> = output enable time to low level

t<sub>PHZ</sub> = output disable time from high level

t<sub>PLZ</sub> = output disable time from low level



**SN54LS373, SN54LS374, SN54S373, SN54S374,  
SN74LS373, SN74LS374, SN74S373, SN74S374  
OCTAL D-TYPE TRANSPARENT LATCHES AND EDGE-TRIGGERED FLIP-FLOPS**

SDLS165B – OCTOBER 1975 – REVISED AUGUST 2002

**schematic of inputs and outputs**

'S373 and 'S374

'S373 and 'S374





**SN54LS373, SN54LS374, SN54S373, SN54S374,  
SN74LS373, SN74LS374, SN74S373, SN74S374**  
**OCTAL D-TYPE TRANSPARENT LATCHES AND EDGE-TRIGGERED FLIP-FLOPS**

SDLS165B – OCTOBER 1975 – REVISED AUGUST 2002

**absolute maximum ratings over operating free-air temperature range (unless otherwise noted)†  
(‘S devices)**

Supply voltage, $V_{CC}$ (see Note 1) .....	7 V
Input voltage, $V_I$ .....	5.5 V
Off-state output voltage .....	5.5 V
Package thermal impedance, $\theta_{JA}$ (see Note 2): DW package .....	58°C/W
N package .....	69°C/W
NS package .....	60°C/W
Storage temperature range, $T_{stg}$ .....	–65°C to 150°C

† Stresses beyond those listed under “absolute maximum ratings” may cause permanent damage to the device. These are stress ratings only, and functional operation of the device at these or any other conditions beyond those indicated under “recommended operating conditions” is not implied. Exposure to absolute-maximum-rated conditions for extended periods may affect device reliability.

- NOTES: 1. Voltage values are with respect to network ground terminal.  
2. The package thermal impedance is calculated in accordance with JESD 51-7.

**recommended operating conditions**

		SN54S'			SN74S'			UNIT
		MIN	NOM	MAX	MIN	NOM	MAX	
$V_{CC}$	Supply voltage	4.5	5	5.5	4.75	5	5.25	V
$V_{OH}$	High-level output voltage			5.5			5.5	V
$I_{OH}$	High-level output current			–2			–6.5	mA
$t_w$	Pulse duration, clock/enable	High	6		6			ns
		Low	7.3		7.3			
$t_{su}$	Data setup time	'S373	0↓		0↓			ns
		'S374	5↑		5↑			
$t_h$	Data hold time	'S373	10↓		10↓			ns
		'S374	2↑		2↑			
$T_A$	Operating free-air temperature	–55		125	0		70	°C



**SN54LS373, SN54LS374, SN54S373, SN54S374,  
SN74LS373, SN74LS374, SN74S373, SN74S374  
OCTAL D-TYPE TRANSPARENT LATCHES AND EDGE-TRIGGERED FLIP-FLOPS**

SDLS165B – OCTOBER 1975 – REVISED AUGUST 2002

**electrical characteristics over recommended operating free-air temperature range (unless otherwise noted) (SN54S373, SN54S374, SN74S373, SN74S374)**

PARAMETER		TEST CONDITIONS†				MIN	TYP‡	MAX	UNIT
V <sub>IH</sub>						2			V
V <sub>IL</sub>								0.8	V
V <sub>IK</sub>		V <sub>CC</sub> = MIN, I <sub>I</sub> = -18 mA						-1.2	V
V <sub>OH</sub>	SN54S'	V <sub>CC</sub> = MIN, V <sub>IH</sub> = 2 V, V <sub>IL</sub> = 0.8 V, I <sub>OH</sub> = MAX				2.4	3.4		V
	SN74S'					2.4	3.1		
V <sub>OL</sub>		V <sub>CC</sub> = MIN, V <sub>IH</sub> = 2 V, V <sub>IL</sub> = 0.8 V, I <sub>OL</sub> = 20 mA						0.5	V
I <sub>OZH</sub>		V <sub>CC</sub> = MAX, V <sub>IH</sub> = 2 V, V <sub>O</sub> = 2.4 V						50	μA
I <sub>OZL</sub>		V <sub>CC</sub> = MAX, V <sub>IH</sub> = 2 V, V <sub>O</sub> = 0.5 V						-50	μA
I <sub>I</sub>		V <sub>CC</sub> = MAX, V <sub>I</sub> = 5.5 V						1	mA
I <sub>IH</sub>		V <sub>CC</sub> = MAX, V <sub>I</sub> = 2.7 V						50	μA
I <sub>IL</sub>		V <sub>CC</sub> = MAX, V <sub>I</sub> = 0.5 V						-250	μA
I <sub>OS</sub> §		V <sub>CC</sub> = MAX				-40		-100	mA
I <sub>CC</sub>	V <sub>CC</sub> = MAX	'S373	Outputs high				160	mA	
			Outputs low				160		
			Outputs disabled				190		
		'S374	Outputs high				110		
			Outputs low				140		
			Outputs disabled				160		
			CLK and $\overline{OC}$ at 4 V, D inputs at 0 V				180		

† For conditions shown as MIN or MAX, use the appropriate value specified under recommended operating conditions.

‡ All typical values are at V<sub>CC</sub> = 5 V, T<sub>A</sub> = 25°C.

§ Not more than one output should be shorted at a time and duration of the short circuit should not exceed one second.

**switching characteristics, V<sub>CC</sub> = 5 V, T<sub>A</sub> = 25°C (see Figure 2)**

PARAMETER	FROM (INPUT)	TO (OUTPUT)	TEST CONDITIONS	'S373			'S374			UNIT
				MIN	TYP	MAX	MIN	TYP	MAX	
f <sub>max</sub>			R <sub>L</sub> = 280 Ω, C <sub>L</sub> = 15 pF, See Note 3				75	100		MHz
t <sub>PLH</sub>	Data	Any Q	R <sub>L</sub> = 280 Ω, C <sub>L</sub> = 15 pF, See Note 3	7	12					ns
t <sub>PHL</sub>				7	12					
t <sub>PLH</sub>	C or CLK	Any Q	R <sub>L</sub> = 280 Ω, C <sub>L</sub> = 15 pF, See Note 3	7	14		8	15		ns
t <sub>PHL</sub>				12	18		11	17		
t <sub>PZH</sub>	$\overline{OC}$	Any Q	R <sub>L</sub> = 280 Ω, C <sub>L</sub> = 15 pF, See Note 3	8	15		8	15		ns
t <sub>PZL</sub>				11	18		11	18		
t <sub>PHZ</sub>	$\overline{OC}$	Any Q	R <sub>L</sub> = 280 Ω, C <sub>L</sub> = 5 pF	6	9		5	9		ns
t <sub>PLZ</sub>				8	12		7	12		

NOTE 3. Maximum clock frequency is tested with all outputs loaded.

f<sub>max</sub> = maximum clock frequency

t<sub>PLH</sub> = propagation delay time, low-to-high-level output

t<sub>PHL</sub> = propagation delay time, high-to-low-level output

t<sub>PZH</sub> = output enable time to high level

t<sub>PZL</sub> = output enable time to low level

t<sub>PHZ</sub> = output disable time from high level

t<sub>PLZ</sub> = output disable time from low level



**SN54LS373, SN54LS374, SN54S373, SN54S374,  
SN74LS373, SN74LS374, SN74S373, SN74S374**

SDLS165B – OCTOBER 1975 – REVISED AUGUST 2002

**PARAMETER MEASUREMENT INFORMATION  
SERIES 54LS/74LS DEVICES**

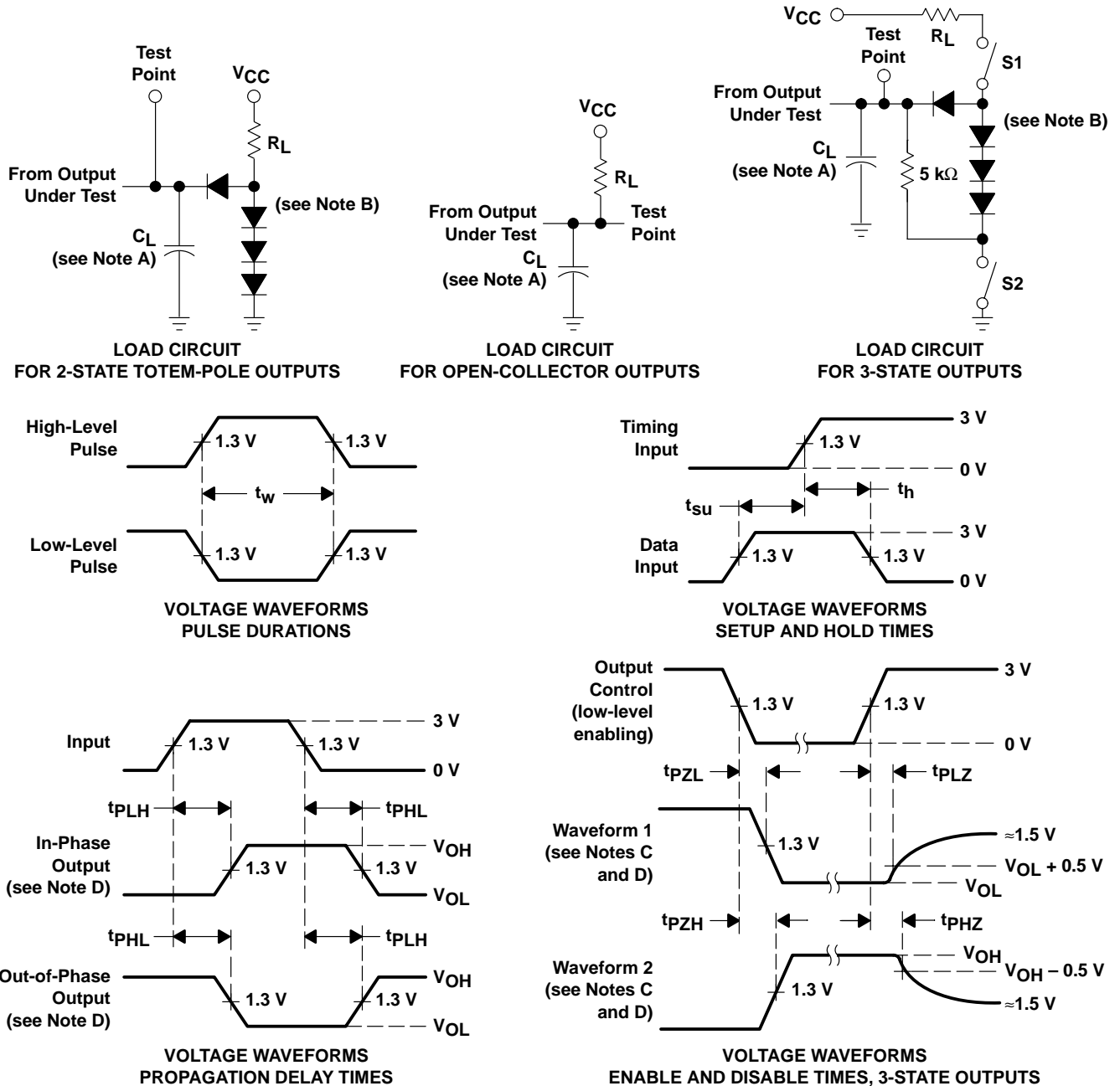

- NOTES: A.  $C_L$  includes probe and jig capacitance.  
 B. All diodes are 1N3064 or equivalent.  
 C. Waveform 1 is for an output with internal conditions such that the output is low except when disabled by the output control. Waveform 2 is for an output with internal conditions such that the output is high except when disabled by the output control.  
 D. S1 and S2 are closed for  $t_{PLH}$ ,  $t_{PHL}$ ,  $t_{PHZ}$ , and  $t_{PLZ}$ ; S1 is open and S2 is closed for  $t_{PZH}$ ; S1 is closed and S2 is open for  $t_{PZL}$ .  
 E. Phase relationships between inputs and outputs have been chosen arbitrarily for these examples.  
 F. All input pulses are supplied by generators having the following characteristics:  $PRR \leq 1$  MHz,  $Z_O \approx 50 \Omega$ ,  $t_r \leq 1.5$  ns,  $t_f \leq 2.6$  ns.  
 G. The outputs are measured one at a time with one input transition per measurement.  
 H. All parameters and waveforms are not applicable to all devices.

**Figure 1. Load Circuits and Voltage Waveforms**

**SN54LS373, SN54LS374, SN54S373, SN54S374,  
SN74LS373, SN74LS374, SN74S373, SN74S374  
OCTAL D-TYPE TRANSPARENT LATCHES AND EDGE-TRIGGERED FLIP-FLOPS**

SDLS165B – OCTOBER 1975 – REVISED AUGUST 2002

**PARAMETER MEASUREMENT INFORMATION  
SERIES 54S/74S DEVICES**



- NOTES: A.  $C_L$  includes probe and jig capacitance.  
 B. All diodes are 1N3064 or equivalent.  
 C. Waveform 1 is for an output with internal conditions such that the output is low except when disabled by the output control. Waveform 2 is for an output with internal conditions such that the output is high except when disabled by the output control.  
 D. S1 and S2 are closed for  $t_{PLH}$ ,  $t_{PHL}$ ,  $t_{PHZ}$ , and  $t_{PLZ}$ ; S1 is open and S2 is closed for  $t_{PZH}$ ; S1 is closed and S2 is open for  $t_{PZL}$ .  
 E. All input pulses are supplied by generators having the following characteristics:  $PRR \leq 1$  MHz,  $Z_O \approx 50 \Omega$ ;  $t_r$  and  $t_f \leq 7$  ns for Series 54/74 devices and  $t_r$  and  $t_f \leq 2.5$  ns for Series 54S/74S devices.  
 F. The outputs are measured one at a time with one input transition per measurement.  
 G. All parameters and waveforms are not applicable to all devices.

**Figure 2. Load Circuits and Voltage Waveforms**



**SN54LS373, SN54LS374, SN54S373, SN54S374,  
SN74LS373, SN74LS374, SN74S373, SN74S374**

SDLS165B – OCTOBER 1975 – REVISED AUGUST 2002

**TYPICAL APPLICATION DATA**

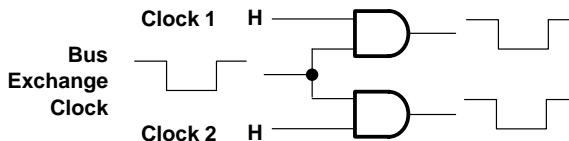

Clock Circuit for Bus Exchange

**Expandable 4-Word by 8-Bit General Register File**

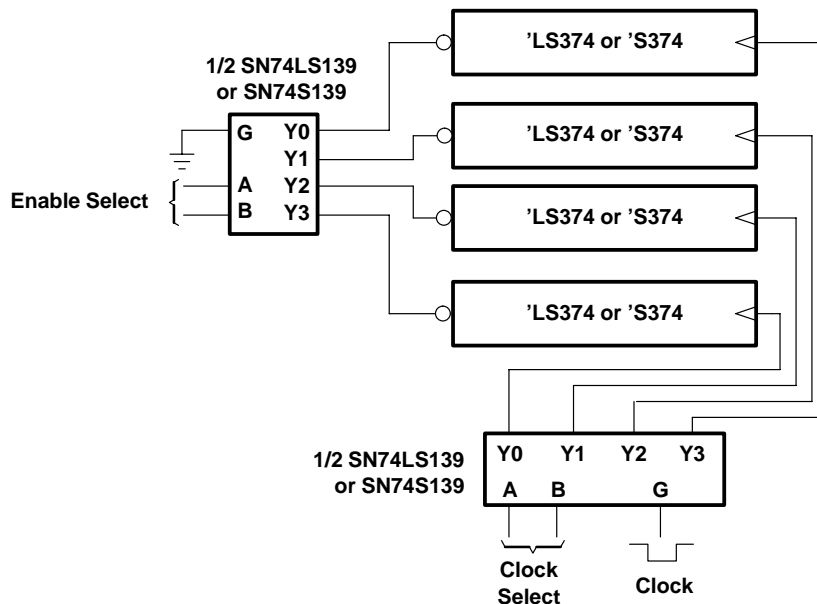

## IMPORTANT NOTICE

Texas Instruments Incorporated and its subsidiaries (TI) reserve the right to make corrections, modifications, enhancements, improvements, and other changes to its products and services at any time and to discontinue any product or service without notice. Customers should obtain the latest relevant information before placing orders and should verify that such information is current and complete. All products are sold subject to TI's terms and conditions of sale supplied at the time of order acknowledgment.

TI warrants performance of its hardware products to the specifications applicable at the time of sale in accordance with TI's standard warranty. Testing and other quality control techniques are used to the extent TI deems necessary to support this warranty. Except where mandated by government requirements, testing of all parameters of each product is not necessarily performed.

TI assumes no liability for applications assistance or customer product design. Customers are responsible for their products and applications using TI components. To minimize the risks associated with customer products and applications, customers should provide adequate design and operating safeguards.

TI does not warrant or represent that any license, either express or implied, is granted under any TI patent right, copyright, mask work right, or other TI intellectual property right relating to any combination, machine, or process in which TI products or services are used. Information published by TI regarding third-party products or services does not constitute a license from TI to use such products or services or a warranty or endorsement thereof. Use of such information may require a license from a third party under the patents or other intellectual property of the third party, or a license from TI under the patents or other intellectual property of TI.

Reproduction of information in TI data books or data sheets is permissible only if reproduction is without alteration and is accompanied by all associated warranties, conditions, limitations, and notices. Reproduction of this information with alteration is an unfair and deceptive business practice. TI is not responsible or liable for such altered documentation.

Resale of TI products or services with statements different from or beyond the parameters stated by TI for that product or service voids all express and any implied warranties for the associated TI product or service and is an unfair and deceptive business practice. TI is not responsible or liable for any such statements.

### Mailing Address:

Texas Instruments  
Post Office Box 655303  
Dallas, Texas 75265