

INTEGRATED CONNECTOR MODULES

0845-2R1T-E4 Gigabit Ethernet MagJack® 2 x 1 with LEDs



LED1 POLARITY			LED2 POLARITY		
PIN 27	PIN 28	COLOR	PIN 29	PIN 30	COLOR
-	+	GREEN	+	-	YELLOW
/	/	/	-	+	GREEN

ELECTRICAL CHARACTERISTICS @ 25°C

URNS RATIO

TP1
TP2
TP3
TP4

ICT : ICT ±2%
ICT : ICT ±2%
ICT : ICT ±2%
ICT : ICT ±2%

OCL @ 100kHz,100mVRMS

8mA DC BIAS

350 uH MIN.

INS. LOSS

100KHZ TO 100MHz

-1.1 dB MAX

RET. LOSS (MIN)

1MHz-30MHz
30MHz-60MHz
60MHz-80MHz
80MHz-100MHz

-18 dB
-16 dB
-14 dB
-12 dB

CM TO CM REJ

100kHz - 100MHz

-25 dB TYP

CROSS TALK

1MHz - 60MHz
60MHz - 100MHz

-35 dB TYP
-25 dB TYP

HIPDT (Isolation Voltage):

1500 Vrms

LEAKAGE INDUCTANCE

PRIMARY w/ SECONDARY SHORTED

0.3uH Max. @ 1MHz

INTERWINDING CAPACITANCE

PER CHANNEL (PRI. TO SEC.)

50pF Max @ 1MHz

DC RESISTANCE

(21-15)=(16-23)=(24-18)=(19-26)

1.2 ohms Max

(RJ1-RJ2)=(RJ3-RJ6)=(RJ4-RJ5)=(RJ7-RJ8)

1.2 ohms Max

LED 1

VF (FORWARD VOLTAGE)
λD (DOMINANT WAVELENGTH)

IF=20mA GREEN 2.2V TYP.
IF=20mA GREEN 565nm TYP.

LED 2

VF (FORWARD VOLTAGE)
λD (DOMINANT WAVELENGTH)

IF=20mA GREEN 2.2V TYP.
IF=20mA YELLOW 2.1V TYP.
IF=20mA GREEN 565nm TYP.
IF=20mA YELLOW 590nm TYP.

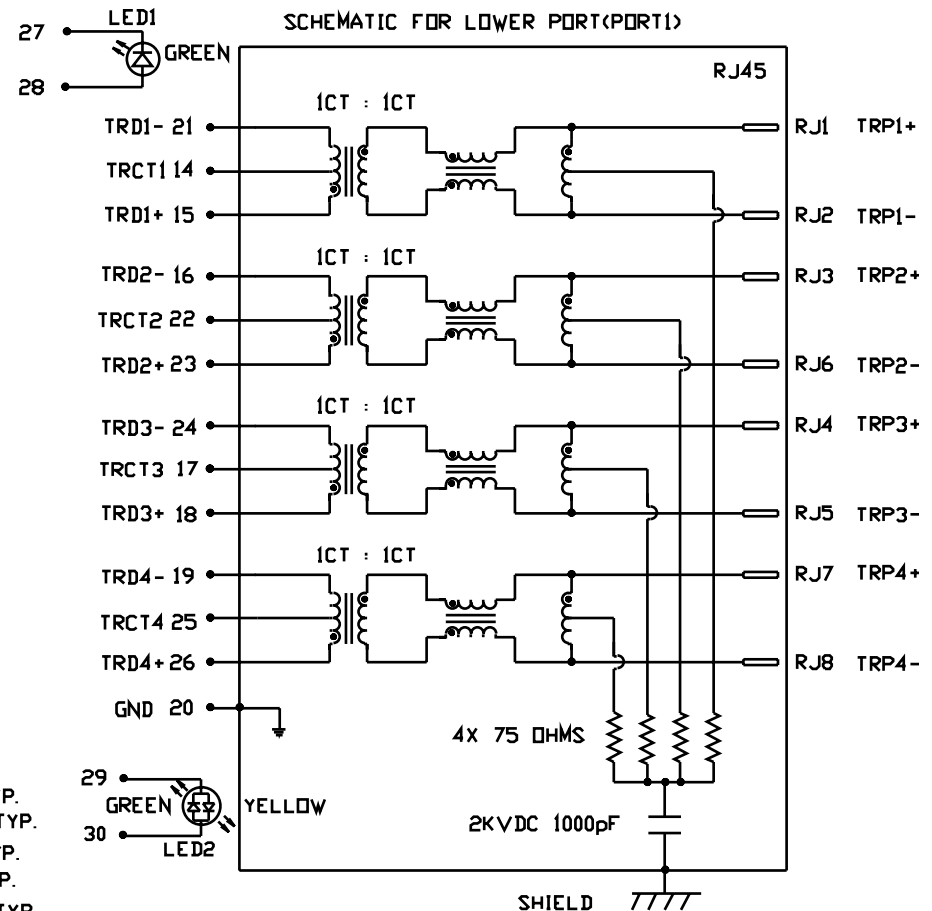

INTEGRATED CONNECTOR MODULES

0845-2R1T-E4 Gigabit Ethernet MagJack® 2 x 1 with LEDs



LED3 POLARITY			LED4 POLARITY		
PIN 31	PIN 32	COLOR	PIN 33	PIN 34	COLOR
-	+	GREEN	+	-	YELLOW
-	+	GREEN	-	+	GREEN

ELECTRICAL CHARACTERISTICS @ 25°C

URNS RATIO

TP1	1CT : 1CT ±2%
TP2	1CT : 1CT ±2%
TP3	1CT : 1CT ±2%
TP4	1CT : 1CT ±2%

□CL @ 100kHz, 100mVRMS

8mA DC BIAS	350 μH MIN.
-------------	-------------

INS. LOSS

100kHz TO 100MHz	-1.1 dB MAX
------------------	-------------

RET. LOSS (MIN)

1MHz-30MHz	-18 dB
30MHz-60MHz	-16 dB
60MHz-80MHz	-14 dB
80MHz-100MHz	-12 dB

CM TO CM REJ

100kHz - 100MHz	-25 dB TYP
-----------------	------------

CROSS TALK

1MHz - 60MHz	-35 dB TYP
60MHz - 100MHz	-25 dB TYP

HIPOT (Isolation Voltage):

1500 Vrms

LEAKAGE INDUCTANCE

PRIMARY W/ SECONDARY SHORTED	0.3μH Max. @ 1MHz
------------------------------	-------------------

INTERWINDING CAPACITANCE

PER CHANNEL (PRI. TO SEC.)	50pF Max @ 1MHz
----------------------------	-----------------

DC RESISTANCE

(13-6)=(5-11)=(10-3)=(2-8)	1.2 ohms Max
(RJ1-RJ2)=(RJ3-RJ6)=(RJ4-RJ5)=(RJ7-RJ8)	1.2 ohms Max

LED 3

V _F (FORWARD VOLTAGE)	IF=20mA	GREEN	2.2V TYP.
λ _D (DOMINANT WAVELENGTH)	IF=20mA	GREEN	565nm TYP.

LED 4

V _F (FORWARD VOLTAGE)	IF=20mA	GREEN	2.2V TYP.
λ _D (DOMINANT WAVELENGTH)	IF=20mA	YELLOW	2.1V TYP.
V _F (FORWARD VOLTAGE)	IF=20mA	GREEN	2.2V TYP.
λ _D (DOMINANT WAVELENGTH)	IF=20mA	YELLOW	590nm TYP.

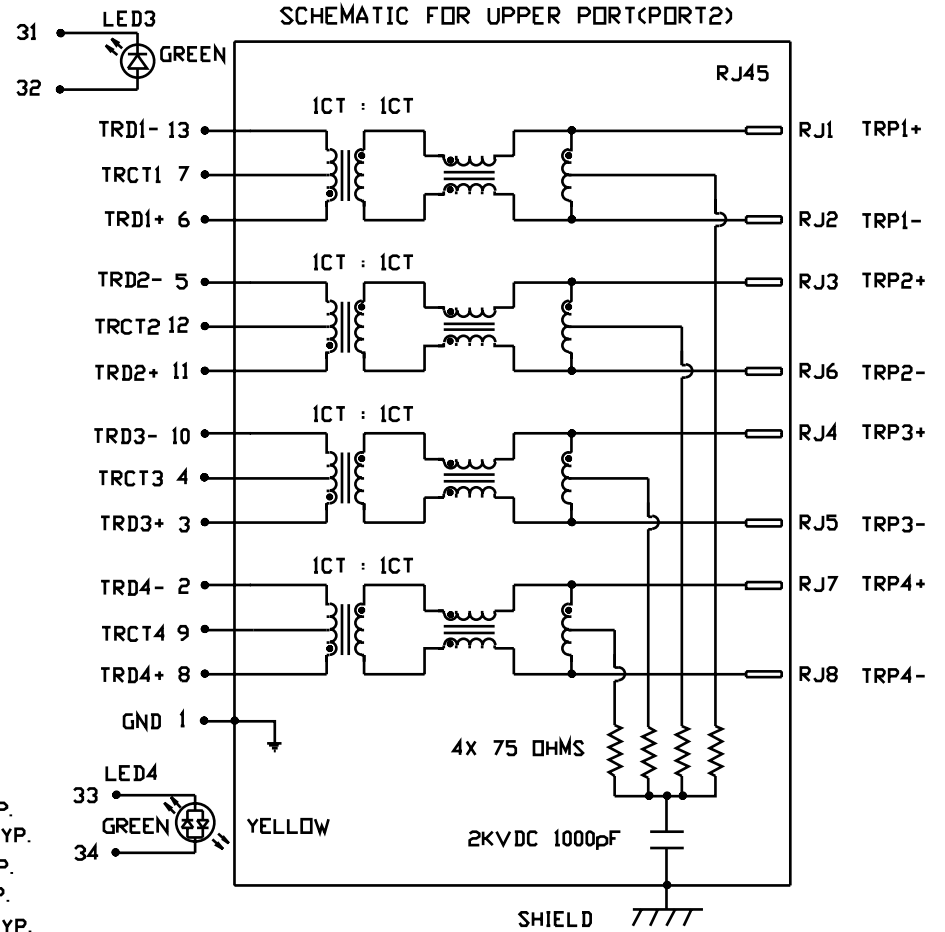

INTEGRATED CONNECTOR MODULES

0845-2R1T-E4 Gigabit Ethernet MagJack® 2 x 1 with LEDs

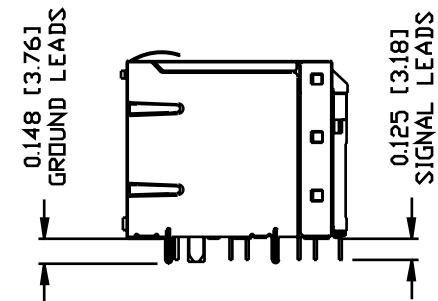
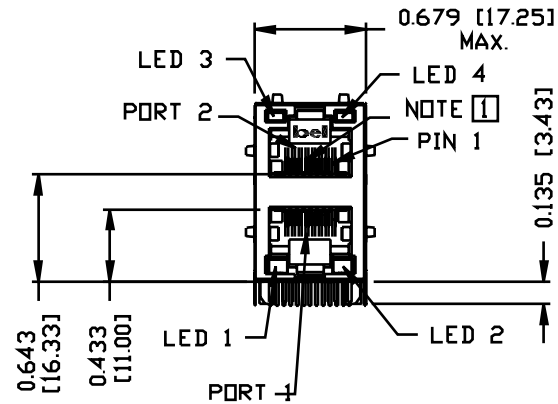
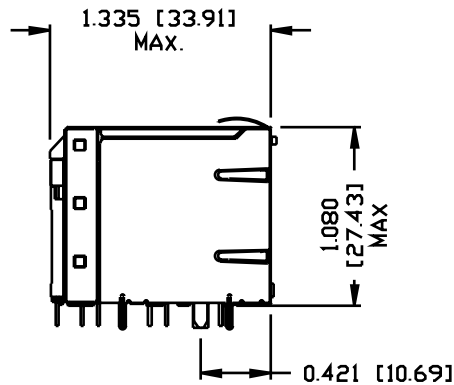
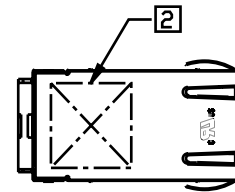

NOTES:

- PLASTIC HOUSING: THERMOPLASTIC PBT
FLAMMABILITY RATING UL 94V-0
- CONTACT PLATING: 50 MICRO-INCH HARD GOLD PLATING
- OUTPUT PINS: TIN-COATED COPPER WIRE, DIA 0.018 INCH.
- METAL SHIELD: NICKEL PLATED COPPER ALLOY.
(ALL GROUND LEADS ARE SOLDER DIPPED)

RoHS COMPLIANCE, PER EU DIRECTIVE 2002/95/EC.

1. JACK CAVITY CONFORMS TO FCC RULES AND REGULATIONS, PART 68 SUBPART F.

2. MARK PART WITH MFG LOGO, MFG NAME, PART NUMBER, AND DATE CODE.

UL US UL RECOGNIZED - FILE #E196366 AND E169987.

INTEGRATED CONNECTOR MODULES

0845-2R1T-E4 Gigabit Ethernet MagJack® 2 x 1 with LEDs

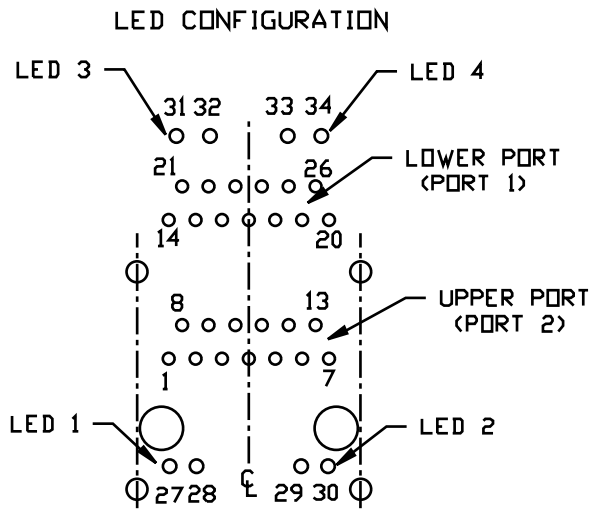

PIN-OUT INFORMATION
(COMPONENT SIDE VIEW)
(SCALE 2:1)

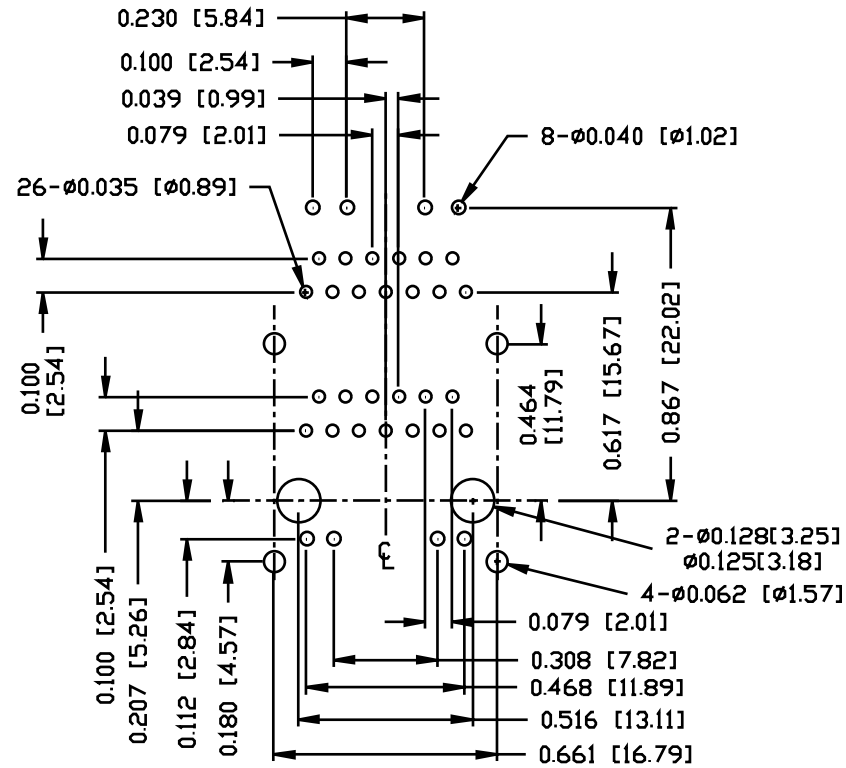

SUGGESTED FOOTPRINT
(COMPONENT SIDE VIEW)
(SCALE 2:1)

INTEGRATED CONNECTOR MODULES

0845-2R1T-E4 Gigabit Ethernet MagJack® 2 x 1 with LEDs

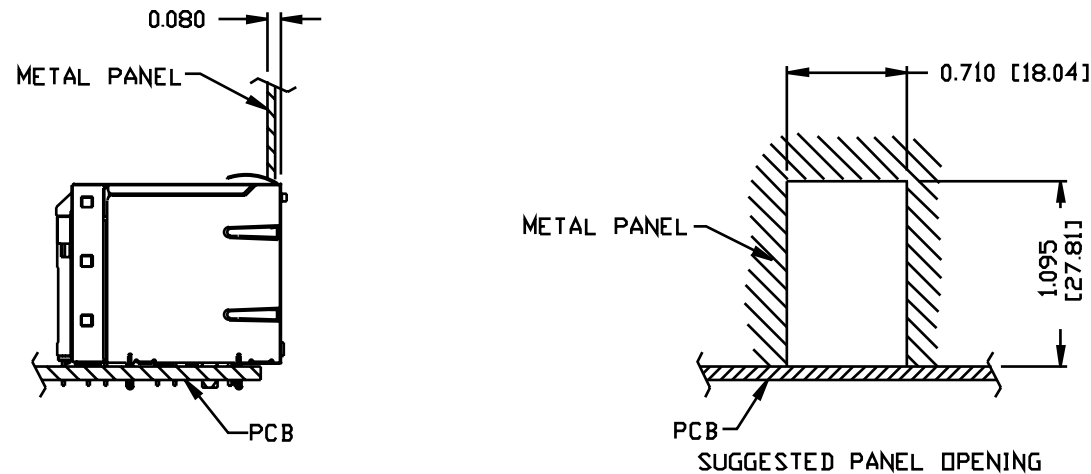

NOTE:

THE DISTANCE OF PANEL INSIDE SURFACE RELATIVE TO FRONT SURFACE OF PART IS ONLY A SUGGESTION. IN CASE THIS DISTANCE IS DIFFERENT, THE REQUIRED PANEL OPENING DIMENSIONS CHANGE ACCORDINGLY.

PACKING INFORMATION

PACKING TRAY: 0200-9999-H5 (TOP)
0200-9999-H6 (BOTTOM)

PACKING QUANTITY: 40 PCS FINISHED GOODS PER TRAY
6 TRAYS (240 PCS FINISHED GOODS) PER CARTON BOX.

NOTE: CARDBOARD ARE PLACED BETWEEN LAYERS OF PACKING TRAY INSIDE CARTON BOX.
(INCLUDE THE UPPERMOST AND LOWEREST TRAY)