

REV.	DESCRIPTION	DATE	APPROVED
#6	.190 WAS .170; REVISED NOTES	DPK 9/23/97	SWN
#7	TWO PLACE DIMS WERE THREE PLACE	DPK 10/10/97	SWN
#8	(2.220) WAS (2.200); ADDED +.010 TOL	DPK 10/10/97	SWN
#9	REMOVED P/N STAMPING NOTE 4	DPK 8/26/98	SWN
#A	ADDED SPOTFACES	LN 1/6/99	SWN
#B	ADDED NOTE 4, CRITICAL CHA. 'O'	AK 10/7/99	SWN

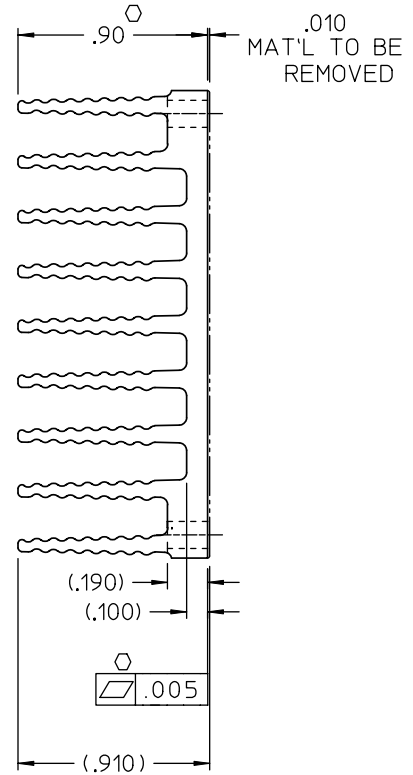
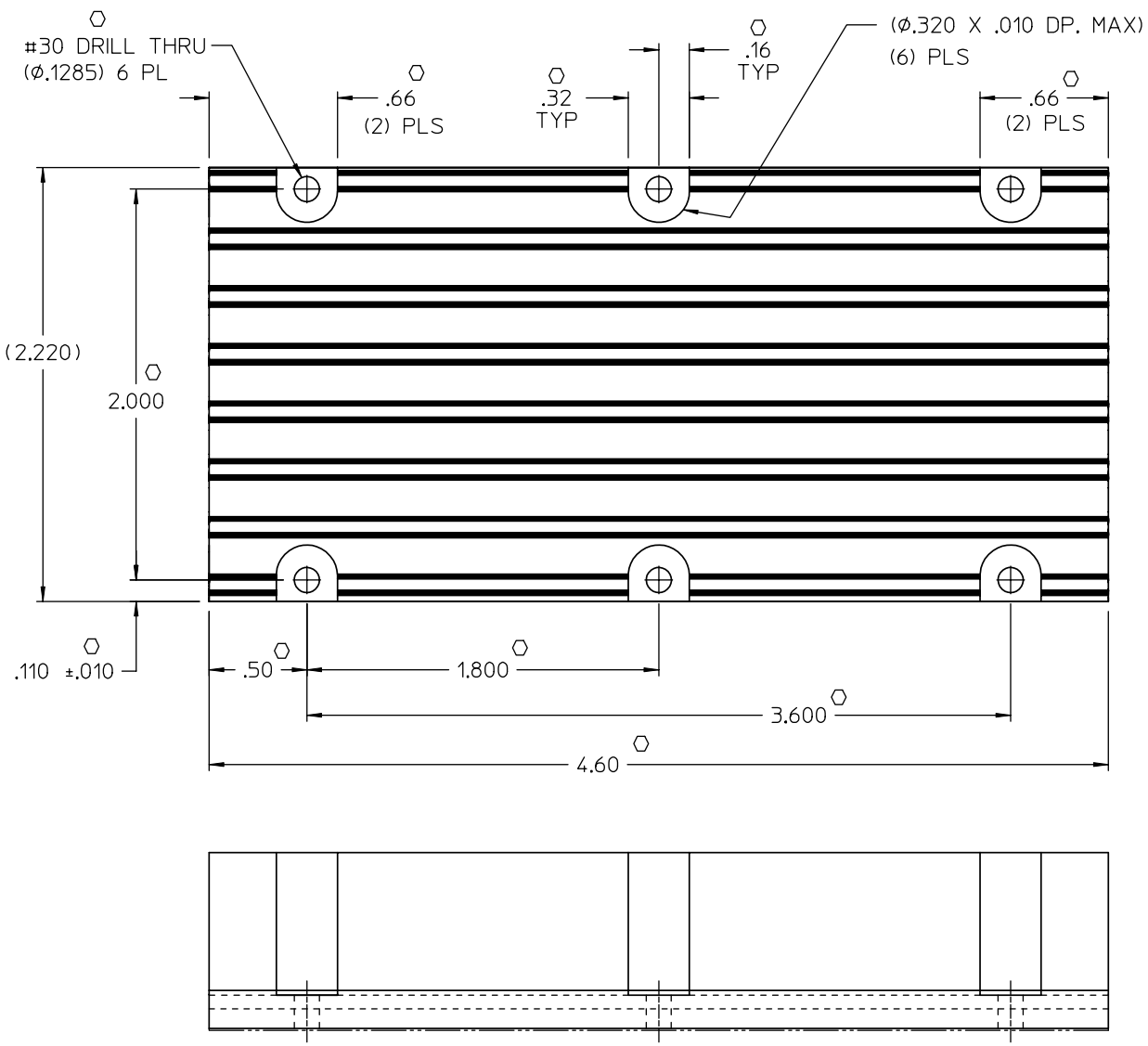

- NOTES
1. MAKE FROM VICOR EXTRUSION P/N 15948.
  2. REMOVE ALL BURRS AND SHARP EDGES.
  3. FINISH: CLEAR CHROMATE.
  4. "O" DENOTES CRITICAL CHARACTERISTICS FOR LOT INSPECTION.

DRAWN BY <b>RENAUD</b>	DATE <b>4/97</b>				
UNLESS OTHERWISE SPECIFIED DIMENSIONS ARE IN INCHES- TOLERANCES ARE: FRACTIONS DECIMALS ANGLES 1/64 .XX ±.01 °1'					
THIRD ANGLE PROJECTION		SIZE <b>C</b>	FSCM NO. <b>67131</b>	DWG NO. <b>17443</b>	REV <b># B</b>
DO NOT SCALE DRAWING		SCALE 2=1	SHEET 1 OF 1		

**HTSNK "A" LONG .9H  
LOW FLOW, THRU HOLE**