

1-24-27



2N5902-2N5909

# 2N5902-2N5909

## Monolithic Dual N-Channel JFET

### General Purpose Amplifier

#### FEATURES

- Tight Tracking
- Good Matching

#### PIN CONFIGURATION

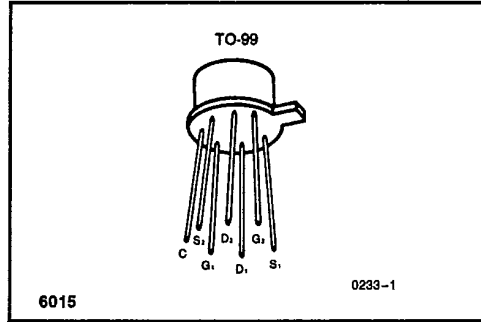

#### ABSOLUTE MAXIMUM RATINGS

(T<sub>A</sub> = 25°C unless otherwise specified)  
 Gate-Drain or Gate-Source Voltage (Note 1) ..... -40V  
 Gate Current (Note 1) ..... 10mA  
 Storage Temperature Range ..... -65°C to +200°C  
 Operating Temperature Range ..... -55°C to +150°C  
 Lead Temperature (Soldering, 10sec) ..... +300°C

	One Side	Both Sides
Power Dissipation	367mW	500mW
Derate above 25°C	3mW/°C	4mW/°C

**NOTE:** Stresses above those listed under "Absolute Maximum Ratings" may cause permanent damage to the device. These are stress ratings only and functional operation of the device at these or any other conditions above those indicated in the operational sections of the specifications is not implied. Exposure to absolute maximum rating conditions for extended periods may affect device reliability.

#### ORDERING INFORMATION

TO-99
2N5902
2N5903
2N5904
2N5905
2N5906
2N5907
2N5908
2N5909

#### ELECTRICAL CHARACTERISTICS (T<sub>A</sub> = 25°C unless otherwise specified)

Symbol	Parameter	Test Conditions	2N5902-6		2N5903-7		2N5904-8		2N5905-9		Units	
			Min	Max	Min	Max	Min	Max	Min	Max		
I <sub>G1</sub> - I <sub>G2</sub>	Differential Gate Current	V <sub>DG</sub> = 10V, I <sub>D</sub> = 30μA, T <sub>A</sub> = 125°C	2N5902-5		2.0		2.0		2.0		2.0	nA
		2N5906-9		0.2		0.2		0.2		0.2		
I <sub>DSS1</sub> I <sub>DSS2</sub>	Saturation Drain Current Ratio	V <sub>DS</sub> = 10V, V <sub>GS</sub> = 0	0.95	1	0.95	1	0.95	1	0.95	1		
g <sub>fs1</sub> g <sub>fs2</sub>	Transconductance Ratio	f = 1kHz	0.97	1	0.97	1	0.95	1	0.95	1		
V <sub>GS1</sub> - V <sub>GS2</sub>	Differential Gate-Source Voltage			5		5		10		15	mV	
Δ V <sub>GS1</sub> - V <sub>GS2</sub>   ΔT	Gate-Source Voltage Differential Drift (Measured at end points T <sub>A</sub> and T <sub>B</sub> )	V <sub>DG</sub> = 10V, I <sub>D</sub> = 30μA, T <sub>A</sub> = 25°C, T <sub>B</sub> = 125°C		5		10		20		40	μV/°C	
		T <sub>A</sub> = -55°C, T <sub>B</sub> = 25°C		5		10		20		40		
		f = 1kHz		0.2		0.2		0.2		0.2	μS	
g <sub>os1</sub> - g <sub>os2</sub>	Differential Output Conductance			0.2		0.2		0.2		0.2	μS	

INTERMIL'S SOLE AND EXCLUSIVE WARRANTY OBLIGATION WITH RESPECT TO THIS PRODUCT SHALL BE THAT STATED IN THE WARRANTY ARTICLE OF THE CONDITION OF SALE. THE WARRANTY SHALL BE EXCLUSIVE AND SHALL BE IN LIEU OF ALL OTHER WARRANTIES, EXPRESS, IMPLIED OR STATUTORY, INCLUDING THE IMPLIED WARRANTIES OF MERCHANTABILITY AND FITNESS FOR A PARTICULAR USE.

NOTE: All typical values have been characterized but are not tested.

**2N5902-2N5909**

INTERNATIONAL

T-29-27

2N5902-2N5909

**ELECTRICAL CHARACTERISTICS** (Continued) ( $T_A = 25^\circ\text{C}$  unless otherwise specified)

Symbol	Parameter	Test Conditions	2N5902-5		2N5906-9		Units	
			Min	Max	Min	Max		
$I_{GSS}$	Gate Reverse Current	$V_{GS} = -20V, V_{DS} = 0$ $T_A = 125^\circ\text{C}$		-5		-2	pA	
				-10		-5	nA	
$BV_{GSS}$	Gate-Source Breakdown Voltage	$I_G = -1\mu\text{A}, V_{DS} = 0$	-40		-40		V	
$V_{GS(off)}$	Gate-Source Cutoff Voltage	$V_{DS} = 10V, I_D = 1\text{nA}$	-0.6	-4.5	-0.6	-4.5		
$V_{GS}$	Gate Source Voltage	$V_{DG} = 10V, I_D = 30\mu\text{A}$		-4		-4		
$I_G$	Gate Operating Current	$T_A = 125^\circ\text{C}$		-3		-1	pA	
				-3		-1	nA	
$I_{DSS}$	Saturation Drain Current	$V_{DS} = 10V, V_{GS} = 0$	f = 1kHz	30	500	30	500	$\mu\text{A}$
$g_{fs}$	Common-Source Forward Transconductance			70	250	70	250	$\mu\text{S}$
$g_{os}$	Common-Source Output Conductance				5		5	
$C_{iss}$	Common-Source Input Capacitance	$V_{DS} = 10V, V_{GS} = 0$ (Note 1)	f = 1MHz		3		3	pF
$C_{rss}$	Common-Source Reverse Transfer Capacitance				1.5		1.5	
$g_{fs}$	Common-Source Forward Transconductance	$V_{DG} = 10V, I_D = 30\mu\text{A}$	f = 1kHz	50	150	50	150	$\mu\text{S}$
$g_{os}$	Common-Source Output Conductance				1		1	
$\bar{e}_n$	Equivalent Short Circuit Input Noise Voltage (Note 1)			$V_{DS} = 10V, V_{GS} = 0$		0.2		0.1
NF	Spot Noise Figure (Note 1)		f = 100Hz $R_G = 10M\Omega$		3		1	dB

NOTE 1: For design reference only, not 100% tested.

10

INTERNATIONAL'S SOLE AND EXCLUSIVE WARRANTY OBLIGATION WITH RESPECT TO THIS PRODUCT SHALL BE THAT STATED IN THE WARRANTY ARTICLE OF THE CONDITION OF SALE. THE WARRANTY SHALL BE EXCLUSIVE AND SHALL BE IN LIEU OF ALL OTHER WARRANTIES, EXPRESS, IMPLIED OR STATUTORY, INCLUDING THE IMPLIED WARRANTIES OF MERCHANTABILITY AND FITNESS FOR A PARTICULAR USE.

NOTE: All typical values have been characterized but are not tested.