

2N6304

**RF & MICROWAVE DISCRETE
 LOW POWER TRANSISTORS**

Features

- Silicon RF NPN, TO-72, UHF general purpose Low Noise Transistor
- Noise Figure = 5.0 dB (typ) @ f = 450 MHz
- High F_T - 1.4 GHz (min) @ $I_C = 10$ mAdc
- Maximum Available Gain = 14 dB (min) @ f = 500 MHz

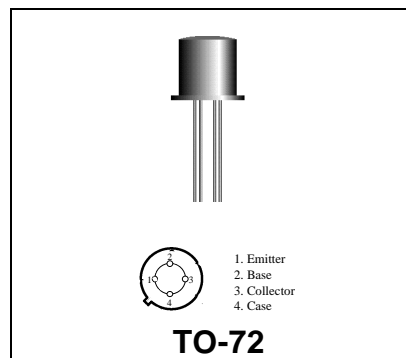

DESCRIPTION:

Designed primarily for use in High Gain, low noise general purpose UHF amplifiers.

ABSOLUTE MAXIMUM RATINGS ($T_{case} = 25^{\circ}C$)

Symbol	Parameter	Value	Unit
V_{CEO}	Collector-Emitter Voltage	15	Vdc
V_{CBO}	Collector-Base Voltage	30	Vdc
V_{EBO}	Emitter-Base Voltage	3.5	Vdc
I_C	Collector Current	50	mA

Thermal Data

P_D	Total Device Dissipation @ $T_A = 25^{\circ}C$ Derate above $25^{\circ}C$	200 1.14	mWatts mW/ $^{\circ}C$
-------	--	-------------	---------------------------

ELECTRICAL SPECIFICATIONS (Tcase = 25°C)

STATIC
 (off)

Symbol	Test Conditions	Value			Unit
		Min.	Typ.	Max.	
BVCEO	Collector-Emitter Breakdown Voltage (IC = 5.0 mA _{dc} , IB = 0)	15	-	-	V _{dc}
BVCBO	Collector-Base Breakdown Voltage (IC = 100 μA _{dc} , IE = 0)	30	-	-	V _{dc}
BVEBO	Emitter-Base Breakdown Voltage (IE = 100 μA _{dc} , IC = 0)	3.5	-	-	V _{dc}
ICBO	Collector Cutoff Current (VCB = 5.0 V _{dc} , IE = 0 V _{dc})	-	-	10	nA _{dc}

(on)

HFE	DC Current Gain (IC = 2.0 mA _{dc} , VCE = 5.0 V _{dc})	25	-	250	-
-----	---	----	---	-----	---

DYNAMIC

Symbol	Test Conditions	Value			Unit
		Min.	Typ.	Max.	
f _T	Current-Gain - Bandwidth Product (IC = 10 mA _{dc} , VCE = 5.0 V _{dc} , f = 100 MHz)	1.4	-	-	GHz
NF	Noise Figure (50 Ohms) (IC = 2 mA _{dc} , VCE = 5.0 V _{dc} , f = 450 MHz)		5.0		dB
CCB	Collector-Base Capacitance (VCB = 10V _{dc} , IE = 0, f = 1 MHz)	-	0.8	1.0	pF

FUNCTIONAL

Symbol	Test Conditions		Value			Unit
			Min.	Typ.	Max.	
$G_{U \max}$	Maximum Unilateral Gain (1)	IC = 14 mAdc, VCE = 10 Vdc, f = 500 MHz	-	14	-	dB
MAG	Maximum Available Gain	IC = 14 mAdc, VCE = 10 Vdc, f = 500 MHz	-	13	-	dB
$ S_{21} ^2$	Insertion Gain	IC = 14 mAdc, VCE = 10 Vdc, f = 500 MHz	9	10	-	dB

Table 1. Common Emitter S-Parameters, @ VCE = 10 V, IC = 14 mA

f (MHz)	S11		S21		S12		S22	
	S11	$\angle \phi$	S21	$\angle \phi$	S12	$\angle \phi$	S22	$\angle \phi$
100	0.430	-46	13.18	119	0.013	61	0.875	-25
200	0.269	-58	8.27	97	0.019	50	0.773	-38
300	0.212	-61	5.35	86	0.024	55	0.749	-50
400	0.192	-69	3.85	77	0.032	50	0.735	-63
500	0.164	-76	3.34	77	0.036	45	0.72	-76
600	0.153	-78	2.92	66	0.042	42	0.725	-89
700	0.170	-87	2.34	58	0.042	40	0.729	-104
800	0.146	-94	1.85	55	0.052	40	0.713	-120
900	0.226	-119	2.66	56	0.065	25	0.757	-136
1000	0.075	152	1.26	36	0.062	13	0.763	-153

PACKAGE STYLE M244

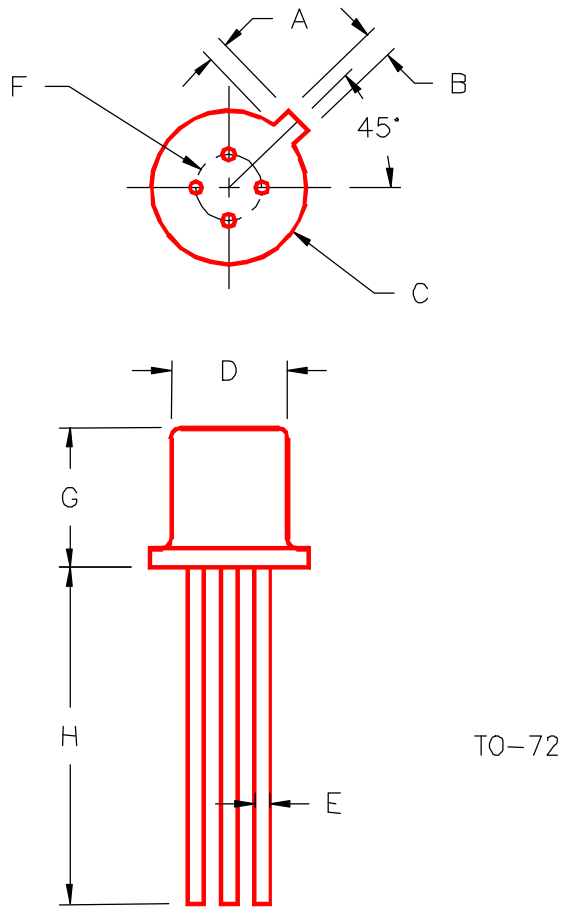

TO-72

	MINIMUM INCHES/MM	MAXIMUM INCHES/MM		MINIMUM INCHES/MM	MAXIMUM INCHES/MM
A	.020/0,51	.048/1,22			
B	.036/0,91	.046/1,17			
C	.209/5,31	.230/5,84			
D	.178/4,52	.195/4,95			
E	.016/0,41	.020/0,51			
F	.100/2,54				
G	.170/4,32	.210/5,33			
H	.500/12,70				