



Intel[®] I/O Controller Hub 6 (ICH6) Family

Datasheet

For the Intel[®] 82801FB ICH6, 82801FR ICH6R and 82801FBM ICH6-M
I/O Controller Hubs

January 2005



INFORMATION IN THIS DOCUMENT IS PROVIDED IN CONNECTION WITH INTEL® PRODUCTS. NO LICENSE, EXPRESS OR IMPLIED, BY ESTOPPEL OR OTHERWISE, TO ANY INTELLECTUAL PROPERTY RIGHTS IS GRANTED BY THIS DOCUMENT. EXCEPT AS PROVIDED IN INTEL'S TERMS AND CONDITIONS OF SALE FOR SUCH PRODUCTS, INTEL ASSUMES NO LIABILITY WHATSOEVER, AND INTEL DISCLAIMS ANY EXPRESS OR IMPLIED WARRANTY, RELATING TO SALE AND/OR USE OF INTEL PRODUCTS INCLUDING LIABILITY OR WARRANTIES RELATING TO FITNESS FOR A PARTICULAR PURPOSE, MERCHANTABILITY, OR INFRINGEMENT OF ANY PATENT, COPYRIGHT OR OTHER INTELLECTUAL PROPERTY RIGHT. Intel products are not intended for use in medical, life saving, or life sustaining applications.

Intel may make changes to specifications and product descriptions at any time, without notice.

Designers must not rely on the absence or characteristics of any features or instructions marked "reserved" or "undefined." Intel reserves these for future definition and shall have no responsibility whatsoever for conflicts or incompatibilities arising from future changes to them.

The Intel® 82801FB ICH6, Intel® 82801FR ICH6R, and Intel® 82801FBM ICH6-M components may contain design defects or errors known as errata which may cause the product to deviate from published specifications. Current characterized errata are available on request.

Contact your local Intel sales office or your distributor to obtain the latest specifications and before placing your product order.

I²C is a two-wire communications bus/protocol developed by Philips. SMBus is a subset of the I²C bus/protocol and was developed by Intel. Implementations of the I²C bus/protocol may require licenses from various entities, including Philips Electronics N.V. and North American Philips Corporation.

Alert on LAN is a result of the Intel-IBM Advanced Manageability Alliance and a trademark of IBM.

Intel, Intel SpeedStep and the Intel logo are trademarks or registered trademarks of Intel Corporation or its subsidiaries in the United States and other countries.

*Other names and brands may be claimed as the property of others.

Copyright © 2004-2005, Intel Corporation

Contents

1	Introduction	43
1.2	Overview	46
2	Signal Description	53
2.1	Direct Media Interface (DMI) to Host Controller.....	56
2.2	PCI Express*	56
2.3	Link to LAN Connect.....	57
2.4	EEPROM Interface	57
2.5	Firmware Hub Interface	57
2.6	PCI Interface	58
2.7	Serial ATA Interface.....	60
2.8	IDE Interface	61
2.9	LPC Interface	62
2.10	Interrupt Interface	63
2.11	USB Interface	64
2.12	Power Management Interface.....	65
2.13	Processor Interface.....	67
2.14	SMBus Interface	68
2.15	System Management Interface	68
2.16	Real Time Clock Interface	69
2.17	Other Clocks	69
2.18	Miscellaneous Signals	69
2.19	AC '97/Intel® High Definition Audio Link	70
2.20	General Purpose I/O.....	71
2.21	Power and Ground.....	73
2.22	Pin Straps	74
2.22.1	Functional Straps	74
2.22.2	External RTC Circuitry	76
2.22.3	Power Sequencing Requirements	76
2.22.3.1	V5REF / Vcc3_3 Sequencing Requirements	76
2.22.3.2	3.3 V/1.5 V Standby Power Sequencing Requirements	76
2.22.3.3	3.3 V/2.5 V Power Sequencing Requirements.....	77
2.22.3.4	Vcc1_5/V_Processor_IO Power Sequencing Requirements	77
3	Pin States	79
3.1	Integrated Pull-Ups and Pull-Downs.....	79
3.2	IDE Integrated Series Termination Resistors	80
3.3	Output and I/O Signals Planes and States	80
3.4	Power Planes for Input Signals.....	89
4	System Clock Domains	95
5	Functional Description	97
5.1	PCI-to-PCI Bridge (D30:F0).....	97
5.1.1	PCI Bus Interface.....	97
5.1.2	PCI Bridge As an Initiator	97
5.1.2.1	Memory Reads and Writes	98

5.1.2.2	I/O Reads and Writes.....	98
5.1.2.3	Configuration Reads and Writes.....	98
5.1.2.4	Locked Cycles.....	98
5.1.2.5	Target / Master Aborts.....	98
5.1.2.6	Secondary Master Latency Timer.....	98
5.1.2.7	Dual Address Cycle (DAC).....	98
5.1.2.8	Memory and I/O Decode to PCI.....	99
5.1.3	Parity Error Detection and Generation.....	99
5.1.4	PCIRST#.....	100
5.1.5	Peer Cycles.....	100
5.1.6	PCI-to-PCI Bridge Model.....	100
5.1.7	IDSEL to Device Number Mapping.....	100
5.1.8	Standard PCI Bus Configuration Mechanism.....	100
5.2	PCI Express* Root Ports (D28:F0,F1,F2,F3).....	101
5.2.1	Interrupt Generation.....	101
5.2.2	Power Management.....	102
5.2.2.1	S3/S4/S5 Support.....	102
5.2.2.2	Resuming from Suspended State.....	102
5.2.2.3	Device Initiated PM_PME Message.....	102
5.2.2.4	SMI/SCI Generation.....	103
5.2.3	SERR# Generation.....	103
5.2.4	Hot-Plug.....	103
5.2.4.1	Presence Detection.....	103
5.2.4.2	Message Generation.....	104
5.2.4.3	Attention Button Detection.....	104
5.2.4.4	SMI/SCI Generation.....	105
5.3	LAN Controller (B1:D8:F0).....	105
5.3.1	LAN Controller PCI Bus Interface.....	106
5.3.1.1	Bus Slave Operation.....	106
5.3.1.2	CLKRUN# Signal (Mobile Only).....	107
5.3.1.3	PCI Power Management.....	107
5.3.1.4	PCI Reset Signal.....	108
5.3.1.5	Wake-Up Events.....	108
5.3.1.6	Wake on LAN* (Preboot Wake-Up).....	109
5.3.2	Serial EEPROM Interface.....	109
5.3.3	CSMA/CD Unit.....	110
5.3.3.1	Full Duplex.....	110
5.3.3.2	Flow Control.....	111
5.3.3.3	VLAN Support.....	111
5.3.4	Media Management Interface.....	111
5.3.5	TCO Functionality.....	111
5.3.5.1	Advanced TCO Mode.....	111
5.4	Alert Standard Format (ASF).....	113
5.4.1	ASF Management Solution Features/Capabilities.....	114
5.4.2	ASF Hardware Support.....	115
5.4.2.1	82562EM/EX.....	115
5.4.2.2	EEPROM (256x16, 1 MHz).....	115
5.4.2.3	Legacy Sensor SMBus Devices.....	115
5.4.2.4	Remote Control SMBus Devices.....	115
5.4.2.5	ASF Sensor SMBus Devices.....	115
5.4.3	ASF Software Support.....	115
5.5	LPC Bridge (w/ System and Management Functions) (D31:F0).....	116

5.5.1	LPC Interface	116
5.5.1.1	LPC Cycle Types	117
5.5.1.2	Start Field Definition.....	117
5.5.1.3	Cycle Type / Direction (CYCTYPE + DIR)	118
5.5.1.4	SIZE	118
5.5.1.5	SYNC	119
5.5.1.6	SYNC Time-Out	119
5.5.1.7	SYNC Error Indication.....	119
5.5.1.8	LFRAME# Usage	119
5.5.1.9	I/O Cycles	120
5.5.1.10	Bus Master Cycles	120
5.5.1.11	LPC Power Management.....	120
5.5.1.12	Configuration and Intel® ICH6 Implications.....	120
5.6	DMA Operation (D31:F0).....	121
5.6.1	Channel Priority	122
5.6.1.1	Fixed Priority	122
5.6.1.2	Rotating Priority	122
5.6.2	Address Compatibility Mode	122
5.6.3	Summary of DMA Transfer Sizes	123
5.6.3.1	Address Shifting When Programmed for 16-Bit I/O Count by Words	123
5.6.4	Autoinitialize.....	123
5.6.5	Software Commands	124
5.7	LPC DMA.....	124
5.7.1	Asserting DMA Requests.....	124
5.7.2	Abandoning DMA Requests	125
5.7.3	General Flow of DMA Transfers	125
5.7.4	Terminal Count	126
5.7.5	Verify Mode.....	126
5.7.6	DMA Request De-assertion	126
5.7.7	SYNC Field / LDRQ# Rules.....	127
5.8	8254 Timers (D31:F0).....	128
5.8.1	Timer Programming	128
5.8.2	Reading from the Interval Timer	129
5.8.2.1	Simple Read	130
5.8.2.2	Counter Latch Command.....	130
5.8.2.3	Read Back Command	130
5.9	8259 Interrupt Controllers (PIC) (D31:F0)	131
5.9.1	Interrupt Handling	132
5.9.1.1	Generating Interrupts	132
5.9.1.2	Acknowledging Interrupts.....	132
5.9.1.3	Hardware/Software Interrupt Sequence.....	133
5.9.2	Initialization Command Words (ICWx).....	133
5.9.2.1	ICW1	133
5.9.2.2	ICW2	134
5.9.2.3	ICW3	134
5.9.2.4	ICW4	134
5.9.3	Operation Command Words (OCW)	134
5.9.4	Modes of Operation	134
5.9.4.1	Fully Nested Mode	134
5.9.4.2	Special Fully-Nested Mode	135
5.9.4.3	Automatic Rotation Mode (Equal Priority Devices)	135

5.9.4.4	Specific Rotation Mode (Specific Priority).....	135
5.9.4.5	Poll Mode.....	135
5.9.4.6	Cascade Mode.....	136
5.9.4.7	Edge and Level Triggered Mode.....	136
5.9.4.8	End of Interrupt (EOI) Operations.....	136
5.9.4.9	Normal End of Interrupt.....	136
5.9.4.10	Automatic End of Interrupt Mode.....	136
5.9.5	Masking Interrupts.....	137
5.9.5.1	Masking on an Individual Interrupt Request.....	137
5.9.5.2	Special Mask Mode.....	137
5.9.6	Steering PCI Interrupts.....	137
5.10	Advanced Programmable Interrupt Controller (APIC) (D31:F0).....	138
5.10.1	Interrupt Handling.....	138
5.10.2	Interrupt Mapping.....	138
5.10.3	PCI / PCI Express* Message-Based Interrupts.....	139
5.10.4	Front Side Bus Interrupt Delivery.....	139
5.10.4.1	Edge-Triggered Operation.....	140
5.10.4.2	Level-Triggered Operation.....	140
5.10.4.3	Registers Associated with Front Side Bus Interrupt Delivery.....	140
5.10.4.4	Interrupt Message Format.....	140
5.11	Serial Interrupt (D31:F0).....	141
5.11.1	Start Frame.....	142
5.11.2	Data Frames.....	142
5.11.3	Stop Frame.....	142
5.11.4	Specific Interrupts Not Supported via SERIRQ.....	143
5.11.5	Data Frame Format.....	143
5.12	Real Time Clock (D31:F0).....	144
5.12.1	Update Cycles.....	144
5.12.2	Interrupts.....	145
5.12.3	Lockable RAM Ranges.....	145
5.12.4	Century Rollover.....	145
5.12.5	Clearing Battery-Backed RTC RAM.....	145
5.13	Processor Interface (D31:F0).....	147
5.13.1	Processor Interface Signals.....	147
5.13.1.1	A20M# (Mask A20).....	147
5.13.1.2	INIT# (Initialization).....	147
5.13.1.3	FERR#/IGNNE# (Numeric Coprocessor Error / Ignore Numeric Error).....	148
5.13.1.4	NMI (Non-Maskable Interrupt).....	149
5.13.1.5	Stop Clock Request and Processor Sleep (STPCLK# and CPUSLP#).....	149
5.13.1.6	Processor Power Good (CPUPWRGOOD).....	149
5.13.1.7	Deeper Sleep (DPSLP#) (Mobile Only).....	149
5.13.2	Dual-Processor Issues (Desktop Only).....	149
5.13.2.1	Signal Differences.....	149
5.13.2.2	Power Management.....	150
5.14	Power Management (D31:F0).....	150
5.14.1	Features.....	150
5.14.2	Intel® ICH6 and System Power States.....	151
5.14.3	System Power Planes.....	153

5.14.4	SMI#/SCI Generation.....	153
5.14.4.1	PCI Express* SCI.....	155
5.14.4.2	PCI Express* Hot-Plug.....	155
5.14.5	Dynamic Processor Clock Control.....	156
5.14.5.1	Transition Rules among S0/Cx and Throttling States.....	157
5.14.5.2	Deferred C3/C4 (Mobile Only).....	157
5.14.5.3	POPOP (Auto C3/C4 to C2) (Mobile Only).....	158
5.14.5.4	POPDOWN (Auto C2 to C3/C4) (Mobile Only).....	158
5.14.6	Dynamic PCI Clock Control (Mobile Only).....	158
5.14.6.1	Conditions for Checking the PCI Clock.....	158
5.14.6.2	Conditions for Maintaining the PCI Clock.....	159
5.14.6.3	Conditions for Stopping the PCI Clock.....	159
5.14.6.4	Conditions for Re-Starting the PCI Clock.....	159
5.14.6.5	LPC Devices and CLKRUN#.....	159
5.14.7	Sleep States.....	160
5.14.7.1	Sleep State Overview.....	160
5.14.7.2	Initiating Sleep State.....	160
5.14.7.3	Exiting Sleep States.....	160
5.14.7.4	PCI Express* WAKE# Signal and PME Event Message.....	162
5.14.7.5	Sx-G3-Sx, Handling Power Failures.....	162
5.14.8	Thermal Management.....	163
5.14.8.1	THRM# Signal.....	163
5.14.8.2	Processor Initiated Passive Cooling.....	163
5.14.8.3	THRM# Override Software Bit.....	163
5.14.8.4	Active Cooling.....	163
5.14.9	Event Input Signals and Their Usage.....	164
5.14.9.1	PWRBTN# (Power Button).....	164
5.14.9.2	RI# (Ring Indicator).....	165
5.14.9.3	PME# (PCI Power Management Event).....	165
5.14.9.4	SYS_RESET# Signal.....	165
5.14.9.5	THRMTRIP# Signal.....	166
5.14.9.6	BMBUSY# (Mobile Only).....	166
5.14.10	ALT Access Mode.....	167
5.14.10.1	Write Only Registers with Read Paths in ALT Access Mode.....	168
5.14.10.2	PIC Reserved Bits.....	169
5.14.10.3	Read Only Registers with Write Paths in ALT Access Mode.....	170
5.14.11	System Power Supplies, Planes, and Signals.....	170
5.14.11.1	Power Plane Control with SLP_S3#, SLP_S4# and SLP_S5#.....	170
5.14.11.2	SLP_S4# and Suspend-To-RAM Sequencing.....	171
5.14.11.3	PWROK Signal.....	171
5.14.11.4	CPUPWRGD Signal.....	171
5.14.11.5	VRMPWRGD Signal.....	171
5.14.11.6	BATLOW# (Battery Low) (Mobile Only).....	171
5.14.11.7	Controlling Leakage and Power Consumption During Low-Power States.....	172
5.14.12	Clock Generators.....	172
5.14.12.1	Clock Control Signals from Intel® ICH6 to Clock Synthesizer (Mobile Only).....	173
5.14.13	Legacy Power Management Theory of Operation.....	173
5.14.13.1	APM Power Management (Desktop Only).....	173
5.14.13.2	Mobile APM Power Management (Mobile Only).....	173
5.15	System Management (D31:F0).....	174
5.15.1	Theory of Operation.....	174

5.15.1.1	Detecting a System Lockup	174
5.15.1.2	Handling an Intruder	174
5.15.1.3	Detecting Improper Firmware Hub Programming	175
5.15.2	Heartbeat and Event Reporting via SMBus	175
5.16	IDE Controller (D31:F1)	179
5.16.1	PIO Transfers	179
5.16.1.1	PIO IDE Timing Modes	179
5.16.1.2	IORDY Masking	180
5.16.1.3	PIO 32-Bit IDE Data Port Accesses	180
5.16.1.4	PIO IDE Data Port Prefetching and Posting	180
5.16.2	Bus Master Function	181
5.16.2.1	Physical Region Descriptor Format	181
5.16.2.2	Bus Master IDE Timings	182
5.16.2.3	Interrupts	182
5.16.2.4	Bus Master IDE Operation	182
5.16.2.5	Error Conditions	183
5.16.3	Ultra ATA/100/66/33 Protocol	184
5.16.3.1	Operation	184
5.16.4	Ultra ATA/33/66/100 Timing	185
5.16.5	ATA Swap Bay	185
5.16.6	SMI Trapping	185
5.17	SATA Host Controller (D31:F2)	186
5.17.1	Theory of Operation	186
5.17.1.1	Standard ATA Emulation	186
5.17.1.2	48-Bit LBA Operation	187
5.17.2	SATA Swap Bay Support	187
5.17.3	Intel® Matrix Storage Technology Configuration (ICH6R Only)	187
5.17.3.1	Intel® Application Accelerator RAID Option ROM	187
5.17.4	Power Management Operation	188
5.17.4.1	Power State Mappings	188
5.17.4.2	Power State Transitions	189
5.17.4.3	SMI Trapping (APM)	190
5.17.5	SATA LED	190
5.17.6	AHCI Operation	190
5.18	High Precision Event Timers	191
5.18.1	Timer Accuracy	191
5.18.2	Interrupt Mapping	191
5.18.3	Periodic vs. Non-Periodic Modes	192
5.18.4	Enabling the Timers	192
5.18.5	Interrupt Levels	193
5.18.6	Handling Interrupts	193
5.18.7	Issues Related to 64-Bit Timers with 32-Bit Processors	193
5.19	USB UHCI Host Controllers (D29:F0, F1, F2, and F3)	194
5.19.1	Data Structures in Main Memory	194
5.19.2	Data Transfers to/from Main Memory	194
5.19.3	Data Encoding and Bit Stuffing	194
5.19.4	Bus Protocol	194
5.19.4.1	Bit Ordering	194
5.19.4.2	SYNC Field	194
5.19.4.3	Packet Field Formats	195
5.19.4.4	Address Fields	195

5.19.4.5	Frame Number Field	195
5.19.4.6	Data Field.....	195
5.19.4.7	Cyclic Redundancy Check (CRC)	195
5.19.5	Packet Formats.....	195
5.19.6	USB Interrupts	195
5.19.6.1	Transaction-Based Interrupts.....	196
5.19.6.2	Non-Transaction Based Interrupts	198
5.19.7	USB Power Management	198
5.19.8	USB Legacy Keyboard Operation.....	199
5.20	USB EHCI Host Controller (D29:F7).....	201
5.20.1	EHC Initialization	201
5.20.1.1	BIOS Initialization.....	201
5.20.1.2	Driver Initialization.....	201
5.20.1.3	EHC Resets	202
5.20.2	Data Structures in Main Memory	202
5.20.3	USB 2.0 Enhanced Host Controller DMA	202
5.20.4	Data Encoding and Bit Stuffing	202
5.20.5	Packet Formats.....	202
5.20.6	USB 2.0 Interrupts and Error Conditions	203
5.20.6.1	Aborts on USB 2.0-Initiated Memory Reads	203
5.20.7	USB 2.0 Power Management	204
5.20.7.1	Pause Feature	204
5.20.7.2	Suspend Feature	204
5.20.7.3	ACPI Device States	204
5.20.7.4	ACPI System States	205
5.20.7.5	Mobile Considerations	205
5.20.8	Interaction with UHCI Host Controllers	205
5.20.8.1	Port-Routing Logic	206
5.20.8.2	Device Connects.....	207
5.20.8.3	Device Disconnects	207
5.20.8.4	Effect of Resets on Port-Routing Logic.....	208
5.20.9	USB 2.0 Legacy Keyboard Operation.....	208
5.20.10	USB 2.0 Based Debug Port	208
5.20.10.1	Theory of Operation	209
5.21	SMBus Controller (D31:F3)	214
5.21.1	Host Controller	214
5.21.1.1	Command Protocols	215
5.21.2	Bus Arbitration	218
5.21.3	Bus Timing.....	219
5.21.3.1	Clock Stretching.....	219
5.21.3.2	Bus Time Out (Intel® ICH6 as SMBus Master)	219
5.21.4	Interrupts / SMI#	220
5.21.5	SMBALERT#	221
5.21.6	SMBus CRC Generation and Checking.....	221
5.21.7	SMBus Slave Interface	221
5.21.7.1	Format of Slave Write Cycle	222
5.21.7.2	Format of Read Command	223
5.21.7.3	Format of Host Notify Command	225
5.22	AC '97 Controller (Audio D30:F2, Modem D30:F3)	226
5.22.1	PCI Power Management.....	228
5.22.2	AC-Link Overview	228

5.22.2.1	Register Access	230
5.22.3	AC-Link Low Power Mode	231
5.22.3.1	External Wake Event	232
5.22.4	AC '97 Cold Reset	233
5.22.5	AC '97 Warm Reset	233
5.22.6	Hardware Assist to Determine ACZ_SDIN Used Per Codec	233
5.23	Intel® High Definition Audio (D27:F0)	234
5.23.1	Link Protocol Overview	234
5.23.1.1	Frame Composition	234
5.23.2	Link Reset	235
5.23.3	Link Power Management	235
6	Register and Memory Mapping	237
6.1	PCI Devices and Functions	238
6.2	PCI Configuration Map	239
6.3	I/O Map	239
6.3.1	Fixed I/O Address Ranges	239
6.3.2	Variable I/O Decode Ranges	242
6.4	Memory Map	243
6.4.1	Boot-Block Update Scheme	244
7	Chipset Configuration Registers	247
7.1	Chipset Configuration Registers (Memory Space)	247
7.1.1	VCH—Virtual Channel Capability Header Register	249
7.1.2	VCAP1—Virtual Channel Capability #1 Register	249
7.1.3	VCAP2—Virtual Channel Capability #2 Register	250
7.1.4	PVC—Port Virtual Channel Control Register	250
7.1.5	PVS—Port Virtual Channel Status Register	250
7.1.6	V0CAP—Virtual Channel 0 Resource Capability Register	251
7.1.7	V0CTL—Virtual Channel 0 Resource Control Register	251
7.1.8	V0STS—Virtual Channel 0 Resource Status Register	252
7.1.9	RCTCL—Root Complex Topology Capabilities List Register	252
7.1.10	ESD—Element Self Description Register	252
7.1.11	ULD—Upstream Link Descriptor Register	253
7.1.12	ULBA—Upstream Link Base Address Register	253
7.1.13	RP1D—Root Port 1 Descriptor Register	253
7.1.14	RP1BA—Root Port 1 Base Address Register	254
7.1.15	RP2D—Root Port 2 Descriptor Register	254
7.1.16	RP2BA—Root Port 2 Base Address Register	254
7.1.17	RP3D—Root Port 3 Descriptor Register	255
7.1.18	RP3BA—Root Port 3 Base Address Register	255
7.1.19	RP4D—Root Port 4 Descriptor Register	255
7.1.20	RP4BA—Root Port 4 Base Address Register	256
7.1.21	HDD—Intel® High Definition Audio Descriptor Register	256
7.1.22	HDBA—Intel® High Definition Audio Base Address Register	256
7.1.23	ILCL—Internal Link Capabilities List Register	257
7.1.24	LCAP—Link Capabilities Register	257
7.1.25	LCTL—Link Control Register	257
7.1.26	LSTS—Link Status Register	258
7.1.27	CSIR5—Chipset Initialization Register 5	258

7.1.28	CSIR6—Chipset Initialization Register 6	258
7.1.29	BCR—Backbone Configuration Register	259
7.1.30	RPC—Root Port Configuration Register	259
7.1.31	CSIR7—Chipset Initialization Register 7	260
7.1.32	TRSR—Trap Status Register.....	260
7.1.33	TRCR—Trapped Cycle Register.....	260
7.1.34	TWDR—Trapped Write Data Register.....	261
7.1.35	IOTRn—I/O Trap Register(0:3).....	261
7.1.36	DMC—DMI Miscellaneous Control Register (Mobile Only)	262
7.1.37	CSCR1—Chipset Configuration Register 1	262
7.1.38	CSCR2—Chipset Configuration Register 2	262
7.1.39	PLLMC—PLL Miscellaneous Control Register (Mobile Only).....	263
7.1.40	TCTL—TCO Configuration Register	263
7.1.41	D31IP—Device 31 Interrupt Pin Register	264
7.1.42	D30IP—Device 30 Interrupt Pin Register	265
7.1.43	D29IP—Device 29 Interrupt Pin Register	266
7.1.44	D28IP—Device 28 Interrupt Pin Register	267
7.1.45	D27IP—Device 27 Interrupt Pin Register	267
7.1.46	D31IR—Device 31 Interrupt Route Register.....	268
7.1.47	D30IR—Device 30 Interrupt Route Register.....	269
7.1.48	D29IR—Device 29 Interrupt Route Register.....	270
7.1.49	D28IR—Device 28 Interrupt Route Register.....	271
7.1.50	D27IR—Device 27 Interrupt Route Register.....	272
7.1.51	OIC—Other Interrupt Control Register.....	273
7.1.52	RC—RTC Configuration Register	273
7.1.53	HPTC—High Precision Timer Configuration Register	274
7.1.54	GCS—General Control and Status Register.....	274
7.1.55	BUC—Backed Up Control Register	276
7.1.56	FD—Function Disable Register	277
7.1.57	CG—Clock Gating	278
7.1.58	CSIR1—Chipset Initialization Register 1	279
7.1.59	CSIR2—Chipset Initialization Register 2	279
7.1.60	CSIR3—Chipset Initialization Register 3	279
7.1.61	CSIR4—Chipset Initialization Register 4	279
8	LAN Controller Registers (B1:D8:F0)	281
8.1	PCI Configuration Registers (LAN Controller—B1:D8:F0)	281
8.1.1	VID—Vendor Identification Register (LAN Controller—B1:D8:F0)	282
8.1.2	DID—Device Identification Register (LAN Controller—B1:D8:F0)	282
8.1.3	PCICMD—PCI Command Register (LAN Controller—B1:D8:F0)	283
8.1.4	PCISTS—PCI Status Register (LAN Controller—B1:D8:F0)	284
8.1.5	RID—Revision Identification Register (LAN Controller—B1:D8:F0)	285

8.1.6	SCC—Sub Class Code Register (LAN Controller—B1:D8:F0)	285
8.1.7	BCC—Base-Class Code Register (LAN Controller—B1:D8:F0)	285
8.1.8	CLS—Cache Line Size Register (LAN Controller—B1:D8:F0)	286
8.1.9	PMLT—Primary Master Latency Timer Register (LAN Controller—B1:D8:F0)	286
8.1.10	HEADTYP—Header Type Register (LAN Controller—B1:D8:F0)	286
8.1.11	CSR_MEM_BASE — CSR Memory-Mapped Base Address Register (LAN Controller—B1:D8:F0)	287
8.1.12	CSR_IO_BASE — CSR I/O-Mapped Base Address Register (LAN Controller—B1:D8:F0)	287
8.1.13	SVID — Subsystem Vendor Identification (LAN Controller—B1:D8:F0)	287
8.1.14	SID — Subsystem Identification (LAN Controller—B1:D8:F0)	288
8.1.15	CAP_PTR — Capabilities Pointer (LAN Controller—B1:D8:F0)	288
8.1.16	INT_LN — Interrupt Line Register (LAN Controller—B1:D8:F0)	288
8.1.17	INT_PN — Interrupt Pin Register (LAN Controller—B1:D8:F0)	289
8.1.18	MIN_GNT — Minimum Grant Register (LAN Controller—B1:D8:F0)	289
8.1.19	MAX_LAT — Maximum Latency Register (LAN Controller—B1:D8:F0)	289
8.1.20	CAP_ID — Capability Identification Register (LAN Controller—B1:D8:F0)	289
8.1.21	NXT_PTR — Next Item Pointer (LAN Controller—B1:D8:F0)	290
8.1.22	PM_CAP — Power Management Capabilities (LAN Controller—B1:D8:F0)	290
8.1.23	PMCSR — Power Management Control/ Status Register (LAN Controller—B1:D8:F0)	291
8.1.24	PCIDATA — PCI Power Management Data Register (LAN Controller—B1:D8:F0)	292
8.2	LAN Control / Status Registers (CSR) (LAN Controller—B1:D8:F0)	293
8.2.1	SCB_STA—System Control Block Status Word Register (LAN Controller—B1:D8:F0)	294
8.2.2	SCB_CMD—System Control Block Command Word Register (LAN Controller—B1:D8:F0)	296
8.2.3	SCB_GENPNT—System Control Block General Pointer Register (LAN Controller—B1:D8:F0)	298
8.2.4	PORT—PORT Interface Register (LAN Controller—B1:D8:F0)	298
8.2.5	EEPROM_CNTL—EEPROM Control Register (LAN Controller—B1:D8:F0)	299
8.2.6	MDI_CNTL—Management Data Interface (MDI) Control Register (LAN Controller—B1:D8:F0)	300

8.2.7	REC_DMA_BC—Receive DMA Byte Count Register (LAN Controller—B1:D8:F0)	300
8.2.8	EREC_INTR—Early Receive Interrupt Register (LAN Controller—B1:D8:F0)	301
8.2.9	FLOW_CNTL—Flow Control Register (LAN Controller—B1:D8:F0)	302
8.2.10	PMDR—Power Management Driver Register (LAN Controller—B1:D8:F0)	303
8.2.11	GENCNTL—General Control Register (LAN Controller—B1:D8:F0)	304
8.2.12	GENSTA—General Status Register (LAN Controller—B1:D8:F0)	304
8.2.13	SMB_PCI—SMB via PCI Register (LAN Controller—B1:D8:F0)	305
8.2.14	Statistical Counters (LAN Controller—B1:D8:F0)	306
8.3	ASF Configuration Registers (LAN Controller—B1:D8:F0)	308
8.3.1	ASF_RID—ASF Revision Identification Register (LAN Controller—B1:D8:F0)	309
8.3.2	SMB_CNTL—SMBus Control Register (LAN Controller—B1:D8:F0)	309
8.3.3	ASF_CNTL—ASF Control Register (LAN Controller—B1:D8:F0)	310
8.3.4	ASF_CNTL_EN—ASF Control Enable Register (ASF Controller—B1:D8:F0)	311
8.3.5	ENABLE—Enable Register (ASF Controller—B1:D8:F0)	312
8.3.6	APM—APM Register (ASF Controller—B1:D8:F0)	313
8.3.7	WTIM_CONF—Watchdog Timer Configuration Register (ASF Controller—B1:D8:F0)	313
8.3.8	HEART_TIM—Heartbeat Timer Register (ASF Controller—B1:D8:F0)	314
8.3.9	RETRAN_INT—Retransmission Interval Register (ASF Controller—B1:D8:F0)	314
8.3.10	RETRAN_PCL—Retransmission Packet Count Limit Register (ASF Controller—B1:D8:F0)	315
8.3.11	ASF_WTIM1—ASF Watchdog Timer 1 Register (ASF Controller—B1:D8:F0)	315
8.3.12	ASF_WTIM2—ASF Watchdog Timer 2 Register (ASF Controller—B1:D8:F0)	315
8.3.13	PET_SEQ1—PET Sequence 1 Register (ASF Controller—B1:D8:F0)	316
8.3.14	PET_SEQ2—PET Sequence 2 Register (ASF Controller—B1:D8:F0)	316
8.3.15	STA—Status Register (ASF Controller—B1:D8:F0)	317
8.3.16	FOR_ACT—Forced Actions Register (ASF Controller—B1:D8:F0)	318
8.3.17	RMCP_SNUM—RMCP Sequence Number Register (ASF Controller—B1:D8:F0)	318

8.3.18	SP_MODE—Special Modes Register (ASF Controller—B1:D8:F0)	319
8.3.19	INPOLL_TCONF—Inter-Poll Timer Configuration Register (ASF Controller—B1:D8:F0)	319
8.3.20	PHIST_CLR—Poll History Clear Register (ASF Controller—B1:D8:F0)	320
8.3.21	PMSK1—Polling Mask 1 Register (ASF Controller—B1:D8:F0)	320
8.3.22	PMSK2—Polling Mask 2 Register (ASF Controller—B1:D8:F0)	321
8.3.23	PMSK3—Polling Mask 3 Register (ASF Controller—B1:D8:F0)	321
8.3.24	PMSK4—Polling Mask 4 Register (ASF Controller—B1:D8:F0)	321
8.3.25	PMSK5—Polling Mask 5 Register (ASF Controller—B1:D8:F0)	322
8.3.26	PMSK6—Polling Mask 6 Register (ASF Controller—B1:D8:F0)	322
8.3.27	PMSK7—Polling Mask 7 Register (ASF Controller—B1:D8:F0)	322
8.3.28	PMSK8—Polling Mask 8 Register (ASF Controller—B1:D8:F0)	323
9	PCI-to-PCI Bridge Registers (D30:F0)	325
9.1	PCI Configuration Registers (D30:F0)	325
9.1.1	VID— Vendor Identification Register (PCI-PCI—D30:F0)	326
9.1.2	DID— Device Identification Register (PCI-PCI—D30:F0)	326
9.1.3	PCICMD—PCI Command (PCI-PCI—D30:F0)	327
9.1.4	PSTS—PCI Status Register (PCI-PCI—D30:F0)	328
9.1.5	RID—Revision Identification Register (PCI-PCI—D30:F0)	329
9.1.6	CC—Class Code Register (PCI-PCI—D30:F0)	329
9.1.7	PMLT—Primary Master Latency Timer Register (PCI-PCI—D30:F0)	330
9.1.8	HEADTYP—Header Type Register (PCI-PCI—D30:F0)	330
9.1.9	BNUM—Bus Number Register (PCI-PCI—D30:F0)	330
9.1.10	SMLT—Secondary Master Latency Timer Register (PCI-PCI—D30:F0)	331
9.1.11	IOBASE_LIMIT—I/O Base and Limit Register (PCI-PCI—D30:F0)	331
9.1.12	SECSTS—Secondary Status Register (PCI-PCI—D30:F0)	332
9.1.13	MEMBASE_LIMIT—Memory Base and Limit Register (PCI-PCI—D30:F0)	333
9.1.14	PREF_MEM_BASE_LIMIT—Prefetchable Memory Base and Limit Register (PCI-PCI—D30:F0)	333
9.1.15	PMBU32—Prefetchable Memory Base Upper 32 Bits Register (PCI-PCI—D30:F0)	334
9.1.16	PMLU32—Prefetchable Memory Limit Upper 32 Bits Register (PCI-PCI—D30:F0)	334
9.1.17	CAPP—Capability List Pointer Register (PCI-PCI—D30:F0)	334
9.1.18	INTR—Interrupt Information Register (PCI-PCI—D30:F0)	334

9.1.19	BCTRL—Bridge Control Register (PCI-PCI—D30:F0)	335
9.1.20	SPDH—Secondary PCI Device Hiding Register (PCI-PCI—D30:F0)	336
9.1.21	PDPR—PCI Decode Policy Register (PCI-PCI—D30:F0)	337
9.1.22	DTC—Delayed Transaction Control Register (PCI-PCI—D30:F0)	338
9.1.23	BPS—Bridge Proprietary Status Register (PCI-PCI—D30:F0)	339
9.1.24	BPC—Bridge Policy Configuration Register (PCI-PCI—D30:F0)	340
9.1.25	SVCAP—Subsystem Vendor Capability Register (PCI-PCI—D30:F0)	340
9.1.26	SVID—Subsystem Vendor IDs Register (PCI-PCI—D30:F0)	341
10	LPC Interface Bridge Registers (D31:F0)	343
10.1	PCI Configuration Registers (LPC I/F—D31:F0)	343
10.1.1	VID—Vendor Identification Register (LPC I/F—D31:F0)	344
10.1.2	DID—Device Identification Register (LPC I/F—D31:F0)	344
10.1.3	PCICMD—PCI COMMAND Register (LPC I/F—D31:F0)	345
10.1.4	PCISTS—PCI Status Register (LPC I/F—D31:F0)	346
10.1.5	RID—Revision Identification Register (LPC I/F—D31:F0)	347
10.1.6	PI—Programming Interface Register (LPC I/F—D31:F0)	347
10.1.7	SCC—Sub Class Code Register (LPC I/F—D31:F0)	347
10.1.8	BCC—Base Class Code Register (LPC I/F—D31:F0)	347
10.1.9	PLT—Primary Latency Timer Register (LPC I/F—D31:F0)	348
10.1.10	HEADTYP—Header Type Register (LPC I/F—D31:F0)	348
10.1.11	SS—Sub System Identifiers Register (LPC I/F—D31:F0)	348
10.1.12	PMBASE—ACPI Base Address Register (LPC I/F—D31:F0)	349
10.1.13	ACPI_CNTL—ACPI Control Register (LPC I/F — D31:F0)	349
10.1.14	GPIOBASE—GPIO Base Address Register (LPC I/F — D31:F0)	350
10.1.15	GC—GPIO Control Register (LPC I/F — D31:F0)	350
10.1.16	PIRQ[n]_ROUT—PIRQ[A,B,C,D] Routing Control Register (LPC I/F—D31:F0)	351
10.1.17	SIRQ_CNTL—Serial IRQ Control Register (LPC I/F—D31:F0)	352
10.1.18	PIRQ[n]_ROUT—PIRQ[E,F,G,H] Routing Control Register (LPC I/F—D31:F0)	353
10.1.19	LPC_I/O_DEC—I/O Decode Ranges Register (LPC I/F—D31:F0)	354
10.1.20	LPC_EN—LPC I/F Enables Register (LPC I/F—D31:F0)	355
10.1.21	GEN1_DEC—LPC I/F Generic Decode Range 1 Register (LPC I/F—D31:F0)	356
10.1.22	GEN2_DEC—LPC I/F Generic Decode Range 2 Register (LPC I/F—D31:F0)	356
10.1.23	FWH_SEL1—Firmware Hub Select 1 Register (LPC I/F—D31:F0)	357
10.1.24	FWH_SEL2—Firmware Hub Select 2 Register (LPC I/F—D31:F0)	358
10.1.25	FWH_DEC_EN1—Firmware Hub Decode Enable Register (LPC I/F—D31:F0)	359

10.1.26	BIOS_CNTL—BIOS Control Register (LPC I/F—D31:F0).....	360
10.1.27	RCBA—Root Complex Base Address Register (LPC I/F—D31:F0).....	361
10.2	DMA I/O Registers (LPC I/F—D31:F0).....	361
10.2.1	DMABASE_CA—DMA Base and Current Address Registers (LPC I/F—D31:F0).....	363
10.2.2	DMABASE_CC—DMA Base and Current Count Registers (LPC I/F—D31:F0).....	363
10.2.3	DMAMEM_LP—DMA Memory Low Page Registers (LPC I/F—D31:F0).....	364
10.2.4	DMACMD—DMA Command Register (LPC I/F—D31:F0).....	364
10.2.5	DMASTA—DMA Status Register (LPC I/F—D31:F0).....	365
10.2.6	DMA_WRSMSK—DMA Write Single Mask Register (LPC I/F—D31:F0).....	365
10.2.7	DMACH_MODE—DMA Channel Mode Register (LPC I/F—D31:F0).....	366
10.2.8	DMA Clear Byte Pointer Register (LPC I/F—D31:F0).....	366
10.2.9	DMA Master Clear Register (LPC I/F—D31:F0).....	367
10.2.10	DMA_CLMSK—DMA Clear Mask Register (LPC I/F—D31:F0).....	367
10.2.11	DMA_WRMSK—DMA Write All Mask Register (LPC I/F—D31:F0).....	367
10.3	Timer I/O Registers (LPC I/F—D31:F0).....	368
10.3.1	TCW—Timer Control Word Register (LPC I/F—D31:F0).....	369
10.3.2	SBYTE_FMT—Interval Timer Status Byte Format Register (LPC I/F—D31:F0).....	371
10.3.3	Counter Access Ports Register (LPC I/F—D31:F0).....	372
10.4	8259 Interrupt Controller (PIC) Registers (LPC I/F—D31:F0).....	372
10.4.1	Interrupt Controller I/O MAP (LPC I/F—D31:F0).....	372
10.4.2	ICW1—Initialization Command Word 1 Register (LPC I/F—D31:F0).....	373
10.4.3	ICW2—Initialization Command Word 2 Register (LPC I/F—D31:F0).....	374
10.4.4	ICW3—Master Controller Initialization Command Word 3 Register (LPC I/F—D31:F0).....	374
10.4.5	ICW3—Slave Controller Initialization Command Word 3 Register (LPC I/F—D31:F0).....	375
10.4.6	ICW4—Initialization Command Word 4 Register (LPC I/F—D31:F0).....	375
10.4.7	OCW1—Operational Control Word 1 (Interrupt Mask) Register (LPC I/F—D31:F0).....	376
10.4.8	OCW2—Operational Control Word 2 Register (LPC I/F—D31:F0).....	376
10.4.9	OCW3—Operational Control Word 3 Register (LPC I/F—D31:F0).....	377
10.4.10	ELCR1—Master Controller Edge/Level Triggered Register (LPC I/F—D31:F0).....	378
10.4.11	ELCR2—Slave Controller Edge/Level Triggered Register (LPC I/F—D31:F0).....	379
10.5	Advanced Programmable Interrupt Controller (APIC)(D31:F0).....	380
10.5.1	APIC Register Map (LPC I/F—D31:F0).....	380

10.5.2	IND—Index Register (LPC I/F—D31:F0)	380
10.5.3	DAT—Data Register (LPC I/F—D31:F0)	381
10.5.4	EOIR—EOI Register (LPC I/F—D31:F0)	381
10.5.5	ID—Identification Register (LPC I/F—D31:F0)	382
10.5.6	VER—Version Register (LPC I/F—D31:F0)	382
10.5.7	REDIR_TBL—Redirection Table (LPC I/F—D31:F0)	383
10.6	Real Time Clock Registers (LPC I/F—D31:F0)	385
10.6.1	I/O Register Address Map (LPC I/F—D31:F0)	385
10.6.2	Indexed Registers (LPC I/F—D31:F0)	386
10.6.2.1	RTC_REGA—Register A (LPC I/F—D31:F0)	387
10.6.2.2	RTC_REGB—Register B (General Configuration) (LPC I/F—D31:F0)	388
10.6.2.3	RTC_REGC—Register C (Flag Register) (LPC I/F—D31:F0)	389
10.6.2.4	RTC_REGD—Register D (Flag Register) (LPC I/F—D31:F0)	389
10.7	Processor Interface Registers (LPC I/F—D31:F0)	390
10.7.1	NMI_SC—NMI Status and Control Register (LPC I/F—D31:F0)	390
10.7.2	NMI_EN—NMI Enable (and Real Time Clock Index) Register (LPC I/F—D31:F0)	391
10.7.3	PORT92—Fast A20 and Init Register (LPC I/F—D31:F0)	391
10.7.4	COPROC_ERR—Coprocessor Error Register (LPC I/F—D31:F0)	392
10.7.5	RST_CNT—Reset Control Register (LPC I/F—D31:F0)	392
10.8	Power Management Registers (PM—D31:F0)	393
10.8.1	Power Management PCI Configuration Registers (PM—D31:F0)	393
10.8.1.1	GEN_PMCON_1—General PM Configuration 1 Register (PM—D31:F0)	394
10.8.1.2	GEN_PMCON_2—General PM Configuration 2 Register (PM—D31:F0)	395
10.8.1.3	GEN_PMCON_3—General PM Configuration 3 Register (PM—D31:F0)	397
10.8.1.4	Cx-STATE_CNF—Cx State Configuration Register (PM—D31:F0) (Mobile Only)	398
10.8.1.5	C4-TIMING_CNT—C4 Timing Control Register (PM—D31:F0) (Mobile Only)	399
10.8.1.6	BM_BREAK_EN Register (PM—D31:F0) (Mobile Only)	400
10.8.1.7	MSC_FUN—Miscellaneous Functionality Register (PM—D31:F0)	401
10.8.1.8	GPI_ROUT—GPI Routing Control Register (PM—D31:F0)	401
10.8.2	APM I/O Decode	402
10.8.2.1	APM_CNT—Advanced Power Management Control Port Register	402
10.8.2.2	APM_STS—Advanced Power Management Status Port Register	402
10.8.3	Power Management I/O Registers	403
10.8.3.1	PM1_STS—Power Management 1 Status Register	404
10.8.3.2	PM1_EN—Power Management 1 Enable Register	406
10.8.3.3	PM1_CNT—Power Management 1 Control	407
10.8.3.4	PM1_TMR—Power Management 1 Timer Register	408

10.8.3.5	PROC_CNT—Processor Control Register	408
10.8.3.6	LV2 — Level 2 Register	410
10.8.3.7	LV3—Level 3 Register (Mobile Only).....	410
10.8.3.8	LV4—Level 4 Register (Mobile Only).....	410
10.8.3.9	PM2_CNT—Power Management 2 Control (Mobile Only)	411
10.8.3.10	GPE0_STS—General Purpose Event 0 Status Register.....	411
10.8.3.11	GPE0_EN—General Purpose Event 0 Enables Register	414
10.8.3.12	SMI_EN—SMI Control and Enable Register	416
10.8.3.13	SMI_STS—SMI Status Register	418
10.8.3.14	ALT_GP_SMI_EN—Alternate GPI SMI Enable Register.....	420
10.8.3.15	ALT_GP_SMI_STS—Alternate GPI SMI Status Register.....	420
10.8.3.16	DEVACT_STS — Device Activity Status Register	421
10.8.3.17	SS_CNT— Intel SpeedStep® Technology Control Register (Mobile Only).....	422
10.8.3.18	C3_RES— C3 Residency Register (Mobile Only)	422
10.9	System Management TCO Registers (D31:F0).....	423
10.9.1	TCO_RLD—TCO Timer Reload and Current Value Register	423
10.9.2	TCO_DAT_IN—TCO Data In Register	424
10.9.3	TCO_DAT_OUT—TCO Data Out Register	424
10.9.4	TCO1_STS—TCO1 Status Register	424
10.9.5	TCO2_STS—TCO2 Status Register	426
10.9.6	TCO1_CNT—TCO1 Control Register.....	427
10.9.7	TCO2_CNT—TCO2 Control Register.....	428
10.9.8	TCO_MESSAGE1 and TCO_MESSAGE2 Registers	428
10.9.9	TCO_WDCNT—TCO Watchdog Control Register	429
10.9.10	SW_IRQ_GEN—Software IRQ Generation Register	429
10.9.11	TCO_TMR—TCO Timer Initial Value Register	429
10.10	General Purpose I/O Registers (D31:F0)	430
10.10.1	GPIO Register I/O Address Map	430
10.10.2	GPIO_USE_SEL—GPIO Use Select Register	431
10.10.3	GP_IO_SEL—GPIO Input/Output Select Register	431
10.10.4	GP_LVL—GPIO Level for Input or Output Register	432
10.10.5	GPO_BLINK—GPO Blink Enable Register	433
10.10.6	GPI_INV—GPIO Signal Invert Register.....	434
10.10.7	GPIO_USE_SEL2—GPIO Use Select 2 Register[63:32]	435
10.10.8	GP_IO_SEL2—GPIO Input/Output Select 2 Register[63:32]	435
10.10.9	GP_LVL2—GPIO Level for Input or Output 2 Register[63:32]	436
11	IDE Controller Registers (D31:F1)	437
11.1	PCI Configuration Registers (IDE—D31:F1)	437
11.1.1	VID—Vendor Identification Register (IDE—D31:F1)	438
11.1.2	DID—Device Identification Register (IDE—D31:F1).....	438
11.1.3	PCICMD—PCI Command Register (IDE—D31:F1)	439
11.1.4	PCISTS — PCI Status Register (IDE—D31:F1).....	440
11.1.5	RID—Revision Identification Register (IDE—D31:F1).....	441
11.1.6	PI—Programming Interface Register (IDE—D31:F1)	441
11.1.7	SCC—Sub Class Code Register (IDE—D31:F1)	441
11.1.8	BCC—Base Class Code Register (IDE—D31:F1).....	442
11.1.9	CLS—Cache Line Size Register (IDE—D31:F1).....	442
11.1.10	PMLT—Primary Master Latency Timer Register (IDE—D31:F1)	442

11.1.11	PCMD_BAR—Primary Command Block Base Address Register (IDE—D31:F1)	442
11.1.12	PCNL_BAR—Primary Control Block Base Address Register (IDE—D31:F1)	443
11.1.13	SCMD_BAR—Secondary Command Block Base Address Register (IDE D31:F1)	443
11.1.14	SCNL_BAR—Secondary Control Block Base Address Register (IDE D31:F1)	443
11.1.15	BM_BASE — Bus Master Base Address Register (IDE—D31:F1)	444
11.1.16	IDE_SVID — Subsystem Vendor Identification (IDE—D31:F1)	444
11.1.17	IDE_SID — Subsystem Identification Register (IDE—D31:F1)	444
11.1.18	INTR_LN—Interrupt Line Register (IDE—D31:F1)	445
11.1.19	INTR_PN—Interrupt Pin Register (IDE—D31:F1)	445
11.1.20	IDE_TIMP — IDE Primary Timing Register (IDE—D31:F1)	445
11.1.21	IDE_TIMS — IDE Secondary Timing Register (IDE—D31:F1)	447
11.1.22	SLV_IDETIM—Slave (Drive 1) IDE Timing Register (IDE—D31:F1)	447
11.1.23	SDMA_CNT—Synchronous DMA Control Register (IDE—D31:F1)	448
11.1.24	SDMA_TIM—Synchronous DMA Timing Register (IDE—D31:F1)	449
11.1.25	IDE_CONFIG—IDE I/O Configuration Register (IDE—D31:F1)	450
11.1.26	ATC—APM Trapping Control Register (IDE—D31:F1)	451
11.1.27	ATS—APM Trapping Status Register (IDE—D31:F1)	451
11.2	Bus Master IDE I/O Registers (IDE—D31:F1)	451
11.2.1	BMICP—Bus Master IDE Command Register (IDE—D31:F1)	452
11.2.2	BMISP—Bus Master IDE Status Register (IDE—D31:F1)	453
11.2.3	BMIDP—Bus Master IDE Descriptor Table Pointer Register (IDE—D31:F1)	453
12	SATA Controller Registers (D31:F2)	455
12.1	PCI Configuration Registers (SATA—D31:F2)	455
12.1.1	VID—Vendor Identification Register (SATA—D31:F2)	456
12.1.2	DID—Device Identification Register (SATA—D31:F2)	457
12.1.3	PCICMD—PCI Command Register (SATA—D31:F2)	457
12.1.4	PCISTS — PCI Status Register (SATA—D31:F2)	458
12.1.5	RID—Revision Identification Register (SATA—D31:F2)	458
12.1.6	PI—Programming Interface Register (SATA—D31:F2)	459
12.1.6.1	When Sub Class Code Register (D31:F2:Offset 0Ah) = 01h	459
12.1.6.2	When Sub Class Code Register (D31:F2:Offset 0Ah) = 04h	459
12.1.6.3	When Sub Class Code Register (D31:F2:Offset 0Ah) = 06h	460
12.1.7	SCC—Sub Class Code Register (SATA—D31:F2)	460
12.1.8	BCC—Base Class Code Register (SATA—D31:F2SATA—D31:F2)	460
12.1.9	PMLT—Primary Master Latency Timer Register (SATA—D31:F2)	461

12.1.10 PCMD_BAR—Primary Command Block Base Address Register (SATA–D31:F2)	461
12.1.11 PCNL_BAR—Primary Control Block Base Address Register (SATA–D31:F2)	461
12.1.12 SCMD_BAR—Secondary Command Block Base Address Register (IDE D31:F1)	462
12.1.13 SCNL_BAR—Secondary Control Block Base Address Register (IDE D31:F1)	462
12.1.14 BAR — Legacy Bus Master Base Address Register (SATA–D31:F2)	462
12.1.15 ABAR — AHCI Base Address Register (SATA–D31:F2)	463
12.1.15.1 Intel® ICH6 Only	463
12.1.15.2 Intel® ICH6R / ICH6-M Only	463
12.1.16 SVID—Subsystem Vendor Identification Register (SATA–D31:F2)	463
12.1.17 SID—Subsystem Identification Register (SATA–D31:F2)	464
12.1.18 CAP—Capabilities Pointer Register (SATA–D31:F2)	464
12.1.19 INT_LN—Interrupt Line Register (SATA–D31:F2)	464
12.1.20 INT_PN—Interrupt Pin Register (SATA–D31:F2)	464
12.1.21 IDE_TIM — IDE Timing Register (SATA–D31:F2)	465
12.1.22 SIDETIM—Slave IDE Timing Register (SATA–D31:F2)	467
12.1.23 SDMA_CNT—Synchronous DMA Control Register (SATA–D31:F2)	468
12.1.24 SDMA_TIM—Synchronous DMA Timing Register (SATA–D31:F2)	469
12.1.25 IDE_CONFIG—IDE I/O Configuration Register (SATA–D31:F2)	470
12.1.26 PID—PCI Power Management Capability Identification Register (SATA–D31:F2)	471
12.1.27 PC—PCI Power Management Capabilities Register (SATA–D31:F2)	471
12.1.28 PMCS—PCI Power Management Control and Status Register (SATA–D31:F2)	472
12.1.29 MAP—Address Map Register (SATA–D31:F2)	472
12.1.30 PCS—Port Control and Status Register (SATA–D31:F2)	473
12.1.31 SIR - SATA Initialization Register	474
12.1.32 SIRI—SATA Indexed Registers Index	475
12.1.33 STRD—SATA Indexed Register Data	475
12.1.34 STTT1—SATA Indexed Registers Index 00h (SATA TX Termination Test Register 1)	476
12.1.35 SIR18—SATA Indexed Registers Index 18h (SATA Initialization Register 18h)	477
12.1.36 STME—SATA Indexed Registers Index 1Ch (SATA Test Mode Enable Register)	477
12.1.37 SIR28—SATA Indexed Registers Index 28h (SATA Initialization Register 28h)	477
12.1.38 STTT2—SATA Indexed Registers Index 74h (SATA TX Termination Test Register 2)	478
12.1.39 SIR84—SATA Indexed Registers Index 84h (SATA Initialization Register 84h)	479
12.1.40 ATC—APM Trapping Control Register (SATA–D31:F2)	479

12.1.41	ATS—APM Trapping Status Register (SATA–D31:F2)	480
12.1.42	SP—Scratch Pad Register (SATA–D31:F2)	480
12.1.43	BFCS—BIST FIS Control/Status Register (SATA–D31:F2)	480
12.1.44	BFTD1—BIST FIS Transmit Data1 Register (SATA–D31:F2)	482
12.1.45	BFTD2—BIST FIS Transmit Data2 Register (SATA–D31:F2)	482
12.2	Bus Master IDE I/O Registers (D31:F2)	483
12.2.1	BMIC[P,S]—Bus Master IDE Command Register (D31:F2)	484
12.2.2	BMIS[P,S]—Bus Master IDE Status Register (D31:F2)	485
12.2.3	BMID[P,S]—Bus Master IDE Descriptor Table Pointer Register (D31:F2)	485
12.3	AHCI Registers (D31:F2)	486
12.3.1	AHCI Generic Host Control Registers (D31:F2)	486
12.3.1.1	CAP—Host Capabilities Register (D31:F2)	487
12.3.1.2	GHC—Global ICH6 Control Register (D31:F2)	488
12.3.1.3	IS—Interrupt Status Register (D31:F2)	489
12.3.1.4	PI—Ports Implemented Register (D31:F2)	490
12.3.1.5	VS—AHCI Version (D31:F2)	490
12.3.2	Port Registers (D31:F2)	491
12.3.2.1	PxCLB—Port [3:0] Command List Base Address Register (D31:F2)	493
12.3.2.2	PxCLBU—Port [3:0] Command List Base Address Upper 32-Bits Register (D31:F2)	493
12.3.2.3	PxFB—Port [3:0] FIS Base Address Register (D31:F2)	493
12.3.2.4	PxFBU—Port [3:0] FIS Base Address Upper 32-Bits Register (D31:F2)	494
12.3.2.5	PxIS—Port [3:0] Interrupt Status Register (D31:F2)	494
12.3.2.6	PxIE—Port [3:0] Interrupt Enable Register (D31:F2)	496
12.3.2.7	PxCMD—Port [3:0] Command Register (D31:F2)	497
12.3.2.8	PxTFD—Port [3:0] Task File Data Register (D31:F2)	499
12.3.2.9	PxSIG—Port [3:0] Signature Register (D31:F2)	500
12.3.2.10	PxSSTS—Port [3:0] Serial ATA Status Register (D31:F2)	501
12.3.2.11	PxSCTL—Port [3:0] Serial ATA Control Register (D31:F2)	502
12.3.2.12	PxSERR—Port [3:0] Serial ATA Error Register (D31:F2)	503
12.3.2.13	PxSACT—Port [3:0] Serial ATA Active (D31:F2)	504
12.3.2.14	PxCI—Port [3:0] Command Issue Register (D31:F2)	505
13	UHCI Controllers Registers	507
13.1	PCI Configuration Registers (USB—D29:F0/F1/F2/F3)	507
13.1.1	VID—Vendor Identification Register (USB—D29:F0/F1/F2/F3)	508
13.1.2	DID—Device Identification Register (USB—D29:F0/F1/F2/F3)	508
13.1.3	PCICMD—PCI Command Register (USB—D29:F0/F1/F2/F3)	508
13.1.4	PCISTS—PCI Status Register (USB—D29:F0/F1/F2/F3)	509
13.1.5	RID—Revision Identification Register (USB—D29:F0/F1/F2/F3)	509
13.1.6	PI—Programming Interface Register (USB—D29:F0/F1/F2/F3)	510
13.1.7	SCC—Sub Class Code Register (USB—D29:F0/F1/F2/F3)	510
13.1.8	BCC—Base Class Code Register (USB—D29:F0/F1/F2/F3)	510

13.1.9	MLT—Master Latency Timer Register (USB—D29:F0/F1/F2/F3)	510
13.1.10	HEADTYP—Header Type Register (USB—D29:F0/F1/F2/F3)	511
13.1.11	BASE—Base Address Register (USB—D29:F0/F1/F2/F3)	511
13.1.12	SVID — Subsystem Vendor Identification Register (USB—D29:F0/F1/F2/F3)	512
13.1.13	SID — Subsystem Identification Register (USB—D29:F0/F1/F2/F3)	512
13.1.14	INT_LN—Interrupt Line Register (USB—D29:F0/F1/F2/F3)	512
13.1.15	INT_PN—Interrupt Pin Register (USB—D29:F0/F1/F2/F3)	513
13.1.16	USB_RELNUM—Serial Bus Release Number Register (USB—D29:F0/F1/F2/F3)	513
13.1.17	USB_LEGKEY—USB Legacy Keyboard/Mouse Control Register (USB—D29:F0/F1/F2/F3)	514
13.1.18	USB_RES—USB Resume Enable Register (USB—D29:F0/F1/F2/F3)	515
13.1.19	CWP—Core Well Policy Register (USB—D29:F0/F1/F2/F3)	516
13.2	USB I/O Registers	516
13.2.1	USBCMD—USB Command Register	517
13.2.2	USBSTS—USB Status Register	520
13.2.3	USBINTR—USB Interrupt Enable Register	521
13.2.4	FRNUM—Frame Number Register	521
13.2.5	FRBASEADD—Frame List Base Address Register	522
13.2.6	SOFMOD—Start of Frame Modify Register	523
13.2.7	PORTSC[0,1]—Port Status and Control Register	524
14	EHCI Controller Registers (D29:F7)	527
14.1	USB EHCI Configuration Registers (USB EHCI—D29:F7)	527
14.1.1	VID—Vendor Identification Register (USB EHCI—D29:F7)	528
14.1.2	DID—Device Identification Register (USB EHCI—D29:F7)	528
14.1.3	PCICMD—PCI Command Register (USB EHCI—D29:F7)	529
14.1.4	PCISTS—PCI Status Register (USB EHCI—D29:F7)	530
14.1.5	RID—Revision Identification Register (USB EHCI—D29:F7)	531
14.1.6	PI—Programming Interface Register (USB EHCI—D29:F7)	531
14.1.7	SCC—Sub Class Code Register (USB EHCI—D29:F7)	531
14.1.8	BCC—Base Class Code Register (USB EHCI—D29:F7)	531
14.1.9	PMLT—Primary Master Latency Timer Register (USB EHCI—D29:F7)	532

14.1.10	MEM_BASE—Memory Base Address Register (USB EHCI—D29:F7)	532
14.1.11	SVID—USB EHCI Subsystem Vendor ID Register (USB EHCI—D29:F7)	532
14.1.12	SID—USB EHCI Subsystem ID Register (USB EHCI—D29:F7)	533
14.1.13	CAP_PTR—Capabilities Pointer Register (USB EHCI—D29:F7)	533
14.1.14	INT_LN—Interrupt Line Register (USB EHCI—D29:F7)	533
14.1.15	INT_PN—Interrupt Pin Register (USB EHCI—D29:F7)	533
14.1.16	PWR_CAPID—PCI Power Management Capability ID Register (USB EHCI—D29:F7)	534
14.1.17	NXT_PTR1—Next Item Pointer #1 Register (USB EHCI—D29:F7)	534
14.1.18	PWR_CAP—Power Management Capabilities Register (USB EHCI—D29:F7)	535
14.1.19	PWR_CNTL_STS—Power Management Control/Status Register (USB EHCI—D29:F7)	536
14.1.20	DEBUG_CAPID—Debug Port Capability ID Register (USB EHCI—D29:F7)	536
14.1.21	NXT_PTR2—Next Item Pointer #2 Register (USB EHCI—D29:F7)	537
14.1.22	DEBUG_BASE—Debug Port Base Offset Register (USB EHCI—D29:F7)	537
14.1.23	USB_RELNUM—USB Release Number Register (USB EHCI—D29:F7)	537
14.1.24	FL_ADJ—Frame Length Adjustment Register (USB EHCI—D29:F7)	538
14.1.25	PWAKE_CAP—Port Wake Capability Register (USB EHCI—D29:F7)	539
14.1.26	LEG_EXT_CAP—USB EHCI Legacy Support Extended Capability Register (USB EHCI—D29:F7)	539
14.1.27	LEG_EXT_CS—USB EHCI Legacy Support Extended Control / Status Register (USB EHCI—D29:F7)	540
14.1.28	SPECIAL_SMI—Intel Specific USB 2.0 SMI Register (USB EHCI—D29:F7)	541
14.1.29	ACCESS_CNTL—Access Control Register (USB EHCI—D29:F7)	543
14.1.30	USB2IR—USB2 Initialization Register (USB EHCI—D29:F7)	543
14.2	Memory-Mapped I/O Registers	544
14.2.1	Host Controller Capability Registers	544
14.2.1.1	CAPLENGTH—Capability Registers Length Register	544
14.2.1.2	HCIVERSION—Host Controller Interface Version Number Register	545
14.2.1.3	HCCPARAMS—Host Controller Structural Parameters	545
14.2.1.4	HCCPARAMS—Host Controller Capability Parameters Register	546
14.2.2	Host Controller Operational Registers	547
14.2.2.1	USB2.0_CMD—USB 2.0 Command Register	548

14.2.2.2	USB2.0_STS—USB 2.0 Status Register	550
14.2.2.3	USB2.0_INTR—USB 2.0 Interrupt Enable Register	552
14.2.2.4	FRINDEX—Frame Index Register	553
14.2.2.5	CTRLDSSEGMENT—Control Data Structure Segment Register.....	554
14.2.2.6	PERIODICLISTBASE—Periodic Frame List Base Address Register.....	554
14.2.2.7	ASYNCLISTADDR—Current Asynchronous List Address Register.....	555
14.2.2.8	CONFIGFLAG—Configure Flag Register	555
14.2.2.9	PORTSC—Port N Status and Control Register	556
14.2.3	USB 2.0-Based Debug Port Register	560
14.2.3.1	CNTL_STS—Control/Status Register.....	560
14.2.3.2	USBPID—USB PIDs Register	562
14.2.3.3	DATABUF[7:0]—Data Buffer Bytes[7:0] Register	562
14.2.3.4	CONFIG—Configuration Register.....	562
15	SMBus Controller Registers (D31:F3).....	563
15.1	PCI Configuration Registers (SMBus—D31:F3).....	563
15.1.1	VID—Vendor Identification Register (SMBus—D31:F3).....	563
15.1.2	DID—Device Identification Register (SMBus—D31:F3).....	564
15.1.3	PCICMD—PCI Command Register (SMBus—D31:F3).....	564
15.1.4	PCISTS—PCI Status Register (SMBus—D31:F3)	565
15.1.5	RID—Revision Identification Register (SMBus—D31:F3)	565
15.1.6	PI—Programming Interface Register (SMBus—D31:F3)	566
15.1.7	SCC—Sub Class Code Register (SMBus—D31:F3).....	566
15.1.8	BCC—Base Class Code Register (SMBus—D31:F3)	566
15.1.9	SMB_BASE—SMBus Base Address Register (SMBus—D31:F3)	566
15.1.10	SVID—Subsystem Vendor Identification Register (SMBus—D31:F2/F4)	567
15.1.11	SID—Subsystem Identification Register (SMBus—D31:F2/F4)	567
15.1.12	INT_LN—Interrupt Line Register (SMBus—D31:F3).....	567
15.1.13	INT_PN—Interrupt Pin Register (SMBus—D31:F3)	567
15.1.14	HOSTC—Host Configuration Register (SMBus—D31:F3)	568
15.2	SMBus I/O Registers	569
15.2.1	HST_STS—Host Status Register (SMBus—D31:F3).....	570
15.2.2	HST_CNT—Host Control Register (SMBus—D31:F3).....	571
15.2.3	HST_CMD—Host Command Register (SMBus—D31:F3)	573
15.2.4	XMIT_SLVA—Transmit Slave Address Register (SMBus—D31:F3)	573
15.2.5	HST_D0—Host Data 0 Register (SMBus—D31:F3).....	573
15.2.6	HST_D1—Host Data 1 Register (SMBus—D31:F3).....	573
15.2.7	Host_BLOCK_DB—Host Block Data Byte Register (SMBus—D31:F3)	574
15.2.8	PEC—Packet Error Check (PEC) Register (SMBus—D31:F3)	574
15.2.9	RCV_SLVA—Receive Slave Address Register (SMBus—D31:F3)	575
15.2.10	SLV_DATA—Receive Slave Data Register (SMBus—D31:F3)	575
15.2.11	AUX_STS—Auxiliary Status Register (SMBus—D31:F3)	575

15.2.12	AUX_CTL—Auxiliary Control Register (SMBus—D31:F3)	576
15.2.13	SMLINK_PIN_CTL—SMLink Pin Control Register (SMBus—D31:F3)	576
15.2.14	SMBus_PIN_CTL—SMBus Pin Control Register (SMBus—D31:F3)	577
15.2.15	SLV_STS—Slave Status Register (SMBus—D31:F3)	577
15.2.16	SLV_CMD—Slave Command Register (SMBus—D31:F3)	578
15.2.17	NOTIFY_DADDR—Notify Device Address Register (SMBus—D31:F3)	578
15.2.18	NOTIFY_DLOW—Notify Data Low Byte Register (SMBus—D31:F3)	579
15.2.19	NOTIFY_DHIGH—Notify Data High Byte Register (SMBus—D31:F3)	579
16	AC '97 Audio Controller Registers (D30:F2)	581
16.1	AC '97 Audio PCI Configuration Space (Audio—D30:F2)	581
16.1.1	VID—Vendor Identification Register (Audio—D30:F2)	582
16.1.2	DID—Device Identification Register (Audio—D30:F2)	582
16.1.3	PCICMD—PCI Command Register (Audio—D30:F2)	583
16.1.4	PCISTS—PCI Status Register (Audio—D30:F2)	584
16.1.5	RID—Revision Identification Register (Audio—D30:F2)	585
16.1.6	PI—Programming Interface Register (Audio—D30:F2)	585
16.1.7	SCC—Sub Class Code Register (Audio—D30:F2)	585
16.1.8	BCC—Base Class Code Register (Audio—D30:F2)	585
16.1.9	HEADTYP—Header Type Register (Audio—D30:F2)	586
16.1.10	NAMBAR—Native Audio Mixer Base Address Register (Audio—D30:F2)	586
16.1.11	NABMBAR—Native Audio Bus Mastering Base Address Register (Audio—D30:F2)	587
16.1.12	MMBAR—Mixer Base Address Register (Audio—D30:F2)	587
16.1.13	MBBAR—Bus Master Base Address Register (Audio—D30:F2)	588
16.1.14	SVID—Subsystem Vendor Identification Register (Audio—D30:F2)	588
16.1.15	SID—Subsystem Identification Register (Audio—D30:F2)	589
16.1.16	CAP_PTR—Capabilities Pointer Register (Audio—D30:F2)	589
16.1.17	INT_LN—Interrupt Line Register (Audio—D30:F2)	589
16.1.18	INT_PN—Interrupt Pin Register (Audio—D30:F2)	590
16.1.19	PCID—Programmable Codec Identification Register (Audio—D30:F2)	590
16.1.20	CFG—Configuration Register (Audio—D30:F2)	590
16.1.21	PID—PCI Power Management Capability Identification Register (Audio—D30:F2)	591
16.1.22	PC—Power Management Capabilities Register (Audio—D30:F2)	591
16.1.23	PCS—Power Management Control and Status Register (Audio—D30:F2)	592
16.2	AC '97 Audio I/O Space (D30:F2)	593
16.2.1	x_BDBAR—Buffer Descriptor Base Address Register (Audio—D30:F2)	596

16.2.2	x_CIV—Current Index Value Register (Audio—D30:F2)	597
16.2.3	x_LVI—Last Valid Index Register (Audio—D30:F2)	597
16.2.4	x_SR—Status Register (Audio—D30:F2)	598
16.2.5	x_PICB—Position In Current Buffer Register (Audio—D30:F2)	599
16.2.6	x_PIV—Prefetched Index Value Register (Audio—D30:F2)	599
16.2.7	x_CR—Control Register (Audio—D30:F2)	600
16.2.8	GLOB_CNT—Global Control Register (Audio—D30:F2)	601
16.2.9	GLOB_STA—Global Status Register (Audio—D30:F2)	603
16.2.10	CAS—Codec Access Semaphore Register (Audio—D30:F2)	605
16.2.11	SDM—SDATA_IN Map Register (Audio—D30:F2)	605
17	AC '97 Modem Controller Registers (D30:F3)	607
17.1	AC '97 Modem PCI Configuration Space (D30:F3)	607
17.1.1	VID—Vendor Identification Register (Modem—D30:F3)	608
17.1.2	DID—Device Identification Register (Modem—D30:F3)	608
17.1.3	PCICMD—PCI Command Register (Modem—D30:F3)	608
17.1.4	PCISTS—PCI Status Register (Modem—D30:F3)	609
17.1.5	RID—Revision Identification Register (Modem—D30:F3)	610
17.1.6	PI—Programming Interface Register (Modem—D30:F3)	610
17.1.7	SCC—Sub Class Code Register (Modem—D30:F3)	610
17.1.8	BCC—Base Class Code Register (Modem—D30:F3)	610
17.1.9	HEADTYP—Header Type Register (Modem—D30:F3)	611
17.1.10	MMBAR—Modem Mixer Base Address Register (Modem—D30:F3)	611
17.1.11	MBAR—Modem Base Address Register (Modem—D30:F3)	612
17.1.12	SVID—Subsystem Vendor Identification Register (Modem—D30:F3)	612
17.1.13	SID—Subsystem Identification Register (Modem—D30:F3)	613
17.1.14	CAP_PTR—Capabilities Pointer Register (Modem—D30:F3)	613
17.1.15	INT_LN—Interrupt Line Register (Modem—D30:F3)	613
17.1.16	INT_PIN—Interrupt Pin Register (Modem—D30:F3)	614
17.1.17	PID—PCI Power Management Capability Identification Register (Modem—D30:F3)	614
17.1.18	PC—Power Management Capabilities Register (Modem—D30:F3)	614
17.1.19	PCS—Power Management Control and Status Register (Modem—D30:F3)	615
17.2	AC '97 Modem I/O Space (D30:F3)	616
17.2.1	x_BDBAR—Buffer Descriptor List Base Address Register (Modem—D30:F3)	618
17.2.2	x_CIV—Current Index Value Register (Modem—D30:F3)	618
17.2.3	x_LVI—Last Valid Index Register (Modem—D30:F3)	618
17.2.4	x_SR—Status Register (Modem—D30:F3)	619
17.2.5	x_PICB—Position in Current Buffer Register (Modem—D30:F3)	620
17.2.6	x_PIV—Prefetch Index Value Register (Modem—D30:F3)	620
17.2.7	x_CR—Control Register (Modem—D30:F3)	621
17.2.8	GLOB_CNT—Global Control Register (Modem—D30:F3)	622
17.2.9	GLOB_STA—Global Status Register (Modem—D30:F3)	623

17.2.10 CAS—Codec Access Semaphore Register (Modem—D30:F3)	625
18 Intel® High Definition Audio Controller Registers (D27:F0)	627
18.1 Intel® High Definition Audio PCI Configuration Space (Intel® High Definition Audio— D27:F0)	627
18.1.1 VID—Vendor Identification Register (Intel® High Definition Audio Controller—D27:F0)	629
18.1.2 DID—Device Identification Register (Intel® High Definition Audio Controller—D27:F0)	629
18.1.3 PCICMD—PCI Command Register (Intel® High Definition Audio Controller—D27:F0)	629
18.1.4 PCISTS—PCI Status Register (Intel® High Definition Audio Controller—D27:F0)	630
18.1.5 RID—Revision Identification Register (Intel® High Definition Audio Controller—D27:F0)	630
18.1.6 PI—Programming Interface Register (Intel® High Definition Audio Controller—D27:F0)	631
18.1.7 SCC—Sub Class Code Register (Intel® High Definition Audio Controller—D27:F0)	631
18.1.8 BCC—Base Class Code Register (Intel® High Definition Audio Controller—D27:F0)	631
18.1.9 CLS—Cache Line Size Register (Intel® High Definition Audio Controller—D27:F0)	631
18.1.10 LT—Latency Timer Register (Intel® High Definition Audio Controller—D27:F0)	632
18.1.11 HEADTYP—Header Type Register (Intel® High Definition Audio Controller—D27:F0)	632
18.1.12 HDBARL—Intel® High Definition Audio Lower Base Address Register (Intel® High Definition Audio Controller—D27:F0)	632
18.1.13 HDBARU—Intel® High Definition Audio Upper Base Address Register (Intel® High Definition Audio Controller—D27:F0)	632
18.1.14 SVID—Subsystem Vendor Identification Register (Intel® High Definition Audio Controller—D27:F0)	633
18.1.15 SID—Subsystem Identification Register (Intel® High Definition Audio Controller—D27:F0)	633
18.1.16 CAPPTR—Capabilities Pointer Register (Audio—D30:F2)	633
18.1.17 INTLN—Interrupt Line Register (Intel® High Definition Audio Controller—D27:F0)	634
18.1.18 INTPN—Interrupt Pin Register (Intel® High Definition Audio Controller—D27:F0)	634
18.1.19 HDCTL—Intel® High Definition Audio Control Register (Intel® High Definition Audio Controller—D27:F0)	635
18.1.20 TCSEL—Traffic Class Select Register (Intel® High Definition Audio Controller—D27:F0)	636
18.1.21 PID—PCI Power Management Capability ID Register (Intel® High Definition Audio Controller—D27:F0)	637
18.1.22 PC—Power Management Capabilities Register (Intel® High Definition Audio Controller—D27:F0)	637

18.1.23 PCS—Power Management Control and Status Register (Intel® High Definition Audio Controller—D27:F0)	638
18.1.24 MID—MSI Capability ID Register (Intel® High Definition Audio Controller—D27:F0)	638
18.1.25 MMC—MSI Message Control Register (Intel® High Definition Audio Controller—D27:F0)	639
18.1.26 MMLA—MSI Message Lower Address Register (Intel® High Definition Audio Controller—D27:F0)	639
18.1.27 MMUA—MSI Message Upper Address Register (Intel® High Definition Audio Controller—D27:F0)	639
18.1.28 MMD—MSI Message Data Register (Intel® High Definition Audio Controller—D27:F0)	639
18.1.29 PXID—PCI Express* Capability ID Register (Intel® High Definition Audio Controller—D27:F0)	640
18.1.30 PXC—PCI Express* Capabilities Register (Intel® High Definition Audio Controller—D27:F0)	640
18.1.31 DEVCAP—Device Capabilities Register (Intel® High Definition Audio Controller—D27:F0)	641
18.1.32 DEVC—Device Control Register (Intel® High Definition Audio Controller—D27:F0)	642
18.1.33 DEVS—Device Status Register (Intel® High Definition Audio Controller—D27:F0)	643
18.1.34 VCCAP—Virtual Channel Enhanced Capability Header (Intel® High Definition Audio Controller—D27:F0)	643
18.1.35 PVCCAP1—Port VC Capability Register 1 (Intel® High Definition Audio Controller—D27:F0)	644
18.1.36 PVCCAP2—Port VC Capability Register 2 (Intel® High Definition Audio Controller—D27:F0)	644
18.1.37 PVCCTL—Port VC Control Register (Intel® High Definition Audio Controller—D27:F0)	644
18.1.38 PVCSTS—Port VC Status Register (Intel® High Definition Audio Controller—D27:F0)	645
18.1.39 VC0CAP—VC0 Resource Capability Register (Intel® High Definition Audio Controller—D27:F0)	645
18.1.40 VC0CTL—VC0 Resource Control Register (Intel® High Definition Audio Controller—D27:F0)	645
18.1.41 VC0STS—VC0 Resource Status Register (Intel® High Definition Audio Controller—D27:F0)	646
18.1.42 VCiCAP—VCi Resource Capability Register (Intel® High Definition Audio Controller—D27:F0)	646
18.1.43 VCiCTL—VCi Resource Control Register (Intel® High Definition Audio Controller—D27:F0)	647
18.1.44 VCiSTS—VCi Resource Status Register (Intel® High Definition Audio Controller—D27:F0)	647
18.1.45 RCCAP—Root Complex Link Declaration Enhanced Capability Header Register (Intel® High Definition Audio Controller—D27:F0) ...	647
18.1.46 ESD—Element Self Description Register (Intel® High Definition Audio Controller—D27:F0)	648
18.1.47 L1DESC—Link 1 Description Register (Intel® High Definition Audio Controller—D27:F0)	648
18.1.48 L1ADDL—Link 1 Lower Address Register (Intel® High Definition Audio Controller—D27:F0)	648

18.1.49	L1ADDU—Link 1 Upper Address Register (Intel® High Definition Audio Controller—D27:F0)	649
18.2	Intel® High Definition Audio Memory Mapped Configuration Registers (Intel® High Definition Audio— D27:F0).....	649
18.2.1	GCAP—Global Capabilities Register (Intel® High Definition Audio Controller—D27:F0)	653
18.2.2	VMIN—Minor Version Register (Intel® High Definition Audio Controller—D27:F0)	653
18.2.3	VMAJ—Major Version Register (Intel® High Definition Audio Controller—D27:F0)	653
18.2.4	OUTPAY—Output Payload Capability Register (Intel® High Definition Audio Controller—D27:F0)	654
18.2.5	INPAY—Input Payload Capability Register (Intel® High Definition Audio Controller—D27:F0)	654
18.2.6	GCTL—Global Control Register (Intel® High Definition Audio Controller—D27:F0)	655
18.2.7	WAKEEN—Wake Enable Register (Intel® High Definition Audio Controller—D27:F0)	656
18.2.8	STATESTS—State Change Status Register (Intel® High Definition Audio Controller—D27:F0)	656
18.2.9	GSTS—Global Status Register (Intel® High Definition Audio Controller—D27:F0)	656
18.2.10	INTCTL—Interrupt Control Register (Intel® High Definition Audio Controller—D27:F0)	657
18.2.11	INTSTS—Interrupt Status Register (Intel® High Definition Audio Controller—D27:F0)	658
18.2.12	WALCLK—Wall Clock Counter Register (Intel® High Definition Audio Controller—D27:F0)	658
18.2.13	SSYNC—Stream Synchronization Register (Intel® High Definition Audio Controller—D27:F0)	659
18.2.14	CORBLOWER—CORB Lower Base Address Register (Intel® High Definition Audio Controller—D27:F0)	660
18.2.15	CORBUPPER—CORB Upper Base Address Register (Intel® High Definition Audio Controller—D27:F0)	660
18.2.16	CORBWRITE—CORB Write Pointer Register (Intel® High Definition Audio Controller—D27:F0)	660
18.2.17	CORBREAD—CORB Read Pointer Register (Intel® High Definition Audio Controller—D27:F0)	661
18.2.18	CORBCTL—CORB Control Register (Intel® High Definition Audio Controller—D27:F0)	661
18.2.19	CORBSTAT—CORB Status Register (Intel® High Definition Audio Controller—D27:F0)	662
18.2.20	CORBFSIZE—CORB Size Register (Intel® High Definition Audio Controller—D27:F0)	662
18.2.21	RORBLOWER—RORB Lower Base Address Register (Intel® High Definition Audio Controller—D27:F0)	662
18.2.22	RORBUPPER—RORB Upper Base Address Register (Intel® High Definition Audio Controller—D27:F0)	663
18.2.23	RORBWRITE—RORB Write Pointer Register (Intel® High Definition Audio Controller—D27:F0)	663
18.2.24	RORBCNT—Response Interrupt Count Register (Intel® High Definition Audio Controller—D27:F0)	663

18.2.25	RIRBCTL—RIRB Control Register (Intel® High Definition Audio Controller—D27:F0)	664
18.2.26	RIRBSTS—RIRB Status Register (Intel® High Definition Audio Controller—D27:F0)	664
18.2.27	RIRBSIZE—RIRB Size Register (Intel® High Definition Audio Controller—D27:F0)	665
18.2.28	IC—Immediate Command Register (Intel® High Definition Audio Controller—D27:F0)	665
18.2.29	IR—Immediate Response Register (Intel® High Definition Audio Controller—D27:F0)	665
18.2.30	IRS—Immediate Command Status Register (Intel® High Definition Audio Controller—D27:F0)	666
18.2.31	DPLBASE—DMA Position Lower Base Address Register (Intel® High Definition Audio Controller—D27:F0)	666
18.2.32	DPUBASE—DMA Position Upper Base Address Register (Intel® High Definition Audio Controller—D27:F0)	667
18.2.33	SDCTL—Stream Descriptor Control Register (Intel® High Definition Audio Controller—D27:F0)	667
18.2.34	SDSTS—Stream Descriptor Status Register (Intel® High Definition Audio Controller—D27:F0)	669
18.2.35	SDLPIB—Stream Descriptor Link Position in Buffer Register (Intel® High Definition Audio Controller—D27:F0)	670
18.2.36	SDCBL—Stream Descriptor Cyclic Buffer Length Register (Intel® High Definition Audio Controller—D27:F0)	670
18.2.37	SDLVI—Stream Descriptor Last Valid Index Register (Intel® High Definition Audio Controller—D27:F0)	671
18.2.38	SDFIFOW—Stream Descriptor FIFO Watermark Register (Intel® High Definition Audio Controller—D27:F0)	671
18.2.39	SDFIFOS—Stream Descriptor FIFO Size Register (Intel® High Definition Audio Controller—D27:F0)	672
18.2.40	SDFMT—Stream Descriptor Format Register (Intel® High Definition Audio Controller—D27:F0)	673
18.2.41	SDBDPL—Stream Descriptor Buffer Descriptor List Pointer Lower Base Address Register (Intel® High Definition Audio Controller—D27:F0)	674
18.2.42	SBDPU—Stream Descriptor Buffer Descriptor List Pointer Upper Base Address Register (Intel® High Definition Audio Controller —D27:F0)	674
19	PCI Express* Configuration Registers	675
19.1	PCI Express* Configuration Registers (PCI Express—D28:F0/F1/F2/F3)	675
19.1.1	VID—Vendor Identification Register (PCI Express—D28:F0/F1/F2/F3)	678
19.1.2	DID—Device Identification Register (PCI Express—D28:F0/F1/F2/F3)	678
19.1.3	PCICMD—PCI Command Register (PCI Express—D28:F0/F1/F2/F3)	679
19.1.4	PCISTS—PCI Status Register (PCI Express—D28:F0/F1/F2/F3)	680
19.1.5	RID—Revision Identification Register (PCI Express—D28:F0/F1/F2/F3)	681

19.1.6	PI—Programming Interface Register (PCI Express—D28:F0/F1/F2/F3).....	681
19.1.7	SCC—Sub Class Code Register (PCI Express—D28:F0/F1/F2/F3).....	681
19.1.8	BCC—Base Class Code Register (PCI Express—D28:F0/F1/F2/F3).....	681
19.1.9	CLS—Cache Line Size Register (PCI Express—D28:F0/F1/F2/F3).....	682
19.1.10	PLT—Primary Latency Timer Register (PCI Express—D28:F0/F1/F2/F3).....	682
19.1.11	HEADTYP—Header Type Register (PCI Express—D28:F0/F1/F2/F3).....	682
19.1.12	BNUM—Bus Number Register (PCI Express—D28:F0/F1/F2/F3).....	682
19.1.13	IOBL—I/O Base and Limit Register (PCI Express—D28:F0/F1/F2/F3).....	683
19.1.14	SSTS—Secondary Status Register (PCI Express—D28:F0/F1/F2/F3).....	684
19.1.15	MBL—Memory Base and Limit Register (PCI Express—D28:F0/F1/F2/F3).....	685
19.1.16	PMBL—Prefetchable Memory Base and Limit Register (PCI Express—D28:F0/F1/F2/F3).....	685
19.1.17	PMBU32—Prefetchable Memory Base Upper 32 Bits Register (PCI Express—D28:F0/F1/F2/F3).....	686
19.1.18	PMLU32—Prefetchable Memory Limit Upper 32 Bits Register (PCI Express—D28:F0/F1/F2/F3).....	686
19.1.19	CAPP—Capabilities List Pointer Register (PCI Express—D28:F0/F1/F2/F3).....	686
19.1.20	INTR—Interrupt Information Register (PCI Express—D28:F0/F1/F2/F3).....	686
19.1.21	BCTRL—Bridge Control Register (PCI Express—D28:F0/F1/F2/F3).....	687
19.1.22	CLIST—Capabilities List Register (PCI Express—D28:F0/F1/F2/F3).....	688
19.1.23	XCAP—PCI Express* Capabilities Register (PCI Express—D28:F0/F1/F2/F3).....	688
19.1.24	DCAP—Device Capabilities Register (PCI Express—D28:F0/F1/F2/F3).....	689
19.1.25	DCTL—Device Control Register (PCI Express—D28:F0/F1/F2/F3).....	690
19.1.26	DSTS—Device Status Register (PCI Express—D28:F0/F1/F2/F3).....	691
19.1.27	LCAP—Link Capabilities Register (PCI Express—D28:F0/F1/F2/F3).....	692
19.1.28	LCTL—Link Control Register (PCI Express—D28:F0/F1/F2/F3).....	693
19.1.29	LSTS—Link Status Register (PCI Express—D28:F0/F1/F2/F3).....	694
19.1.30	SLCAP—Slot Capabilities Register (PCI Express—D28:F0/F1/F2/F3).....	695
19.1.31	SLCTL—Slot Control Register (PCI Express—D28:F0/F1/F2/F3).....	696

19.1.32 SLSTS—Slot Status Register (PCI Express—D28:F0/F1/F2/F3)	697
19.1.33 RCTL—Root Control Register (PCI Express—D28:F0/F1/F2/F3)	698
19.1.34 RSTS—Root Status Register (PCI Express—D28:F0/F1/F2/F3)	698
19.1.35 MID—Message Signaled Interrupt Identifiers Register (PCI Express—D28:F0/F1/F2/F3)	699
19.1.36 MC—Message Signaled Interrupt Message Control Register (PCI Express—D28:F0/F1/F2/F3)	699
19.1.37 MA—Message Signaled Interrupt Message Address Register (PCI Express—D28:F0/F1/F2/F3)	699
19.1.38 MD—Message Signaled Interrupt Message Data Register (PCI Express—D28:F0/F1/F2/F3)	700
19.1.39 SVCAP—Subsystem Vendor Capability Register (PCI Express—D28:F0/F1/F2/F3)	700
19.1.40 SVID—Subsystem Vendor Identification Register (PCI Express—D28:F0/F1/F2/F3)	700
19.1.41 PMCAP—Power Management Capability Register (PCI Express—D28:F0/F1/F2/F3)	700
19.1.42 PMC—PCI Power Management Capabilities Register (PCI Express—D28:F0/F1/F2/F3)	701
19.1.43 PMCS—PCI Power Management Control and Status Register (PCI Express—D28:F0/F1/F2/F3)	702
19.1.44 MPC—Miscellaneous Port Configuration Register (PCI Express—D28:F0/F1/F2/F3)	703
19.1.45 SMSCS—SMI/SCI Status Register (PCI Express—D28:F0/F1/F2/F3)	704
19.1.46 VCH—Virtual Channel Capability Header Register (PCI Express—D28:F0/F1/F2/F3)	704
19.1.47 VCAP2—Virtual Channel Capability 2 Register (PCI Express—D28:F0/F1/F2/F3)	704
19.1.48 PVC—Port Virtual Channel Control Register (PCI Express—D28:F0/F1/F2/F3)	705
19.1.49 PVS — Port Virtual Channel Status Register (PCI Express—D28:F0/F1/F2/F3)	705
19.1.50 V0CAP — Virtual Channel 0 Resource Capability Register (PCI Express—D28:F0/F1/F2/F3)	705
19.1.51 V0CTL — Virtual Channel 0 Resource Control Register (PCI Express—D28:F0/F1/F2/F3)	706
19.1.52 V0STS — Virtual Channel 0 Resource Status Register (PCI Express—D28:F0/F1/F2/F3)	706
19.1.53 UES — Uncorrectable Error Status Register (PCI Express—D28:F0/F1/F2/F3)	707
19.1.54 UEM — Uncorrectable Error Mask (PCI Express—D28:F0/F1/F2/F3)	708
19.1.55 UEV — Uncorrectable Error Severity (PCI Express—D28:F0/F1/F2/F3)	709
19.1.56 CES — Correctable Error Status Register (PCI Express—D28:F0/F1/F2/F3)	710
19.1.57 CEM — Correctable Error Mask Register (PCI Express—D28:F0/F1/F2/F3)	710

19.1.58	AECC — Advanced Error Capabilities and Control Register (PCI Express—D28:F0/F1/F2/F3).....	711
19.1.59	RES — Root Error Status Register (PCI Express—D28:F0/F1/F2/F3).....	711
19.1.60	RCTCL — Root Complex Topology Capability List Register (PCI Express—D28:F0/F1/F2/F3).....	711
19.1.61	ESD — Element Self Description Register (PCI Express—D28:F0/F1/F2/F3).....	712
19.1.62	ULD — Upstream Link Description Register (PCI Express—D28:F0/F1/F2/F3).....	712
19.1.63	ULBA — Upstream Link Base Address Register (PCI Express—D28:F0/F1/F2/F3).....	713
19.1.64	PCIECR1 — PCI Express Configuration Register 1 (PCI Express—D28:F0/F1/F2/F3).....	713
19.1.65	PCIECR2 — PCI Express Configuration Register 2 (PCI Express—D28:F0/F1/F2/F3).....	713
20	High Precision Event Timer Registers	715
20.1	Memory Mapped Registers.....	716
20.1.1	GCAP_ID—General Capabilities and Identification Register.....	717
20.1.2	GEN_CONF—General Configuration Register.....	717
20.1.3	GINTR_STA—General Interrupt Status Register	718
20.1.4	MAIN_CNT—Main Counter Value Register.....	718
20.1.5	TIMn_CONF—Timer n Configuration and Capabilities Register	719
20.1.6	TIMn_COMP—Timer n Comparator Value Register.....	721
21	Ballout Definition	723
22	Electrical Characteristics	733
22.1	Thermal Specifications	733
22.2	Absolute Maximum Ratings	733
22.3	DC Characteristics.....	734
22.4	AC Characteristics	743
22.5	Timing Diagrams.....	759
23	Package Information	777
24	Testability	779
24.1	XOR Chain Test Mode Description.....	779
24.1.1	XOR Chain Testability Algorithm Example	780
24.2	XOR Chain Tables.....	781

Figures

1	Desktop Configuration	42
2	Mobile Configuration	42
2-1	Intel® ICH6 Interface Signals Block Diagram (Desktop)	54
2-2	Intel® ICH6-M Interface Signals Block Diagram (Mobile Only)	55
2-3	Example External RTC Circuit	76
4-1	Desktop Conceptual System Clock Diagram	96
4-2	Mobile Conceptual Clock Diagram	96
5-1	Generation of SERR# to Platform	103
5-2	64-Word EEPROM Read Instruction Waveform	110
5-3	LPC Interface Diagram	116
5-4	Intel® ICH6 DMA Controller	121
5-5	DMA Request Assertion through LDRQ#	124
5-6	Coprocessor Error Timing Diagram	148
5-7	Physical Region Descriptor Table Entry	181
5-8	SATA Power States	189
5-9	USB Legacy Keyboard Flow Diagram	199
5-10	Intel® ICH6-USB Port Connections	206
5-11	Intel® ICH6-Based Audio Codec '97 Specification, Version 2.3	227
5-12	AC '97 2.3 Controller-Codec Connection	229
5-13	AC-Link Protocol	230
5-14	AC-Link Powerdown Timing	231
5-15	SDIN Wake Signaling	232
5-16	Intel® High Definition Audio Link Protocol Example	234
21-1	Intel® ICH6 Preliminary Ballout (Topview–Left Side)	724
21-2	Intel® ICH6 Preliminary Ballout (Topview–Right Side)	725
22-1	Clock Timing	759
22-2	Valid Delay from Rising Clock Edge	759
22-3	Setup and Hold Times	759
22-4	Float Delay	760
22-5	Pulse Width	760
22-6	Output Enable Delay	760
22-7	IDE PIO Mode	761
22-8	IDE Multiword DMA	761
22-9	Ultra ATA Mode (Drive Initiating a Burst Read)	762
22-10	Ultra ATA Mode (Sustained Burst)	762
22-11	Ultra ATA Mode (Pausing a DMA Burst)	763
22-12	Ultra ATA Mode (Terminating a DMA Burst)	763
22-13	USB Rise and Fall Times	764
22-14	USB Jitter	764
22-15	USB EOP Width	764
22-16	SMBus Transaction	765
22-17	SMBus Timeout	765
22-18	Power Sequencing and Reset Signal Timings (Desktop Only)	766
22-19	Power Sequencing and Reset Signal Timings (Mobile Only)	767
22-20	G3 (Mechanical Off) to S0 Timings (Desktop Only)	768
22-21	G3 (Mechanical Off) to S0 Timings (Mobile Only)	769
22-22	S0 to S1 to S0 Timing	769
22-23	S0 to S5 to S0 Timings, S3 _{COLD} (Desktop Only)	770
22-24	S0 to S5 to S0 Timings, S3 _{HOT} (Desktop Only)	771

22-25S0 to S5 to S0 Timings, S3 _{COLD} (Mobile Only).....	772
22-26S0 to S5 to S0 Timings, S3 _{HOT} (Mobile Only)	773
22-27C0 to C2 to C0 Timings (Mobile Only)	773
22-28C0 to C3 to C0 Timings (Mobile Only)	774
22-29C0 to C4 to C0 Timings (Mobile Only)	774
22-30AC '97 Data Input and Output Timings	775
22-31Intel® High Definition Audio Input and Output Timings	775
23-1 Intel® ICH6 Package (Top and Side Views)	777
23-2 Intel® ICH6 Package (Bottom View)	778
24-1 XOR Chain Test Mode Selection, Entry and Testing.....	779
24-2 Example XOR Chain Circuitry	780

Tables

1-1 Industry Specifications.....	43
1-2 PCI Devices and Functions	47
2-1 Direct Media Interface Signals.....	56
2-2 PCI Express* Signals.....	56
2-3 LAN Connect Interface Signals.....	57
2-4 EEPROM Interface Signals	57
2-5 Firmware Hub Interface Signals	57
2-6 PCI Interface Signals	58
2-7 Serial ATA Interface Signals.....	60
2-8 IDE Interface Signals	61
2-9 LPC Interface Signals.....	62
2-10 Interrupt Signals.....	63
2-11 USB Interface Signals.....	64
2-12 Power Management Interface Signals.....	65
2-13 Processor Interface Signals.....	67
2-14 SM Bus Interface Signals	68
2-15 System Management Interface Signals	68
2-16 Real Time Clock Interface	69
2-17 Other Clocks	69
2-18 Miscellaneous Signals	69
2-19 AC '97/Intel® High Definition Audio Link Signals	70
2-20 General Purpose I/O Signals	71
2-21 Power and Ground Signals.....	73
2-22 Functional Strap Definitions.....	74
3-1 Integrated Pull-Up and Pull-Down Resistors	79
3-2 IDE Series Termination Resistors.....	80
3-3 Power Plane and States for Output and I/O Signals for Desktop Configurations	81
3-4 Power Plane and States for Output and I/O Signals for Mobile Configurations.....	85
3-5 Power Plane for Input Signals for Desktop Configurations.....	89
3-6 Power Plane for Input Signals for Mobile Configurations	91
4-1 Intel® ICH6 and System Clock Domains	95
5-1 PCI Bridge Initiator Cycle Types.....	97
5-2 MSI vs. PCI IRQ Actions.....	101
5-3 Advanced TCO Functionality	112
5-4 LPC Cycle Types Supported	117

5-5 Start Field Bit Definitions	117
5-6 Cycle Type Bit Definitions.....	118
5-7 Transfer Size Bit Definition	118
5-8 SYNC Bit Definition	119
5-9 DMA Transfer Size	123
5-10 Address Shifting in 16-Bit I/O DMA Transfers	123
5-11 Counter Operating Modes	129
5-12 Interrupt Controller Core Connections	131
5-13 Interrupt Status Registers	132
5-14 Content of Interrupt Vector Byte	132
5-15 APIC Interrupt Mapping	138
5-16 Interrupt Message Address Format	140
5-17 Interrupt Message Data Format	141
5-18 Stop Frame Explanation	142
5-19 Data Frame Format	143
5-20 Configuration Bits Reset by RTCRST# Assertion	146
5-21 INIT# Going Active	148
5-22 NMI Sources	149
5-23 DP Signal Differences	149
5-24 General Power States for Systems Using Intel® ICH6	151
5-25 State Transition Rules for Intel® ICH6	152
5-26 System Power Plane	153
5-27 Causes of SMI# and SCI	154
5-28 Break Events (Mobile Only)	156
5-29 Sleep Types.....	160
5-30 Causes of Wake Events	161
5-31 GPI Wake Events	161
5-32 Transitions Due to Power Failure	162
5-33 Transitions Due to Power Button	164
5-34 Transitions Due to RI# Signal	165
5-35 Write Only Registers with Read Paths in ALT Access Mode	168
5-36 PIC Reserved Bits Return Values	169
5-37 Register Write Accesses in ALT Access Mode	170
5-38 Intel® ICH6 Clock Inputs.....	172
5-39 Heartbeat Message Data.....	178
5-40 IDE Transaction Timings (PCI Clocks)	180
5-41 Interrupt/Active Bit Interaction Definition	183
5-42 Legacy Replacement Routing	191
5-43 Bits Maintained in Low Power States	198
5-44 USB Legacy Keyboard State Transitions	200
5-45 UHCI vs. EHCI.....	201
5-46 Debug Port Behavior	210
5-47 I ² C Block Read	217
5-48 Enable for SMBALERT#.....	220
5-49 Enables for SMBus Slave Write and SMBus Host Events	220
5-50 Enables for the Host Notify Command	220
5-51 Slave Write Registers	222
5-52 Command Types	222
5-53 Read Cycle Format.....	223
5-54 Data Values for Slave Read Registers	224

5-55 Host Notify Format	225
5-56 Features Supported by Intel® ICH6	226
5-57 Output Tag Slot 0	231
6-1 PCI Devices and Functions	238
6-2 Fixed I/O Ranges Decoded by Intel® ICH6	240
6-3 Variable I/O Decode Ranges	242
6-4 Memory Decode Ranges from Processor Perspective	243
7-1 Chipset Configuration Register Memory Map (Memory Space)	247
8-1 LAN Controller PCI Register Address Map (LAN Controller—B1:D8:F0)	281
8-2 Configuration of Subsystem ID and Subsystem Vendor ID via EEPROM	288
8-3 Data Register Structure	292
8-4 Intel® ICH6 Integrated LAN Controller CSR Space Register Address Map	293
8-5 Self-Test Results Format	299
8-6 Statistical Counters	306
8-7 ASF PCI Configuration Register Address Map (LAN Controller—B1:D8:F0)	308
9-1 PCI Bridge Register Address Map (PCI-PCI—D30:F0)	325
10-1 LPC Interface PCI Register Address Map (LPC I/F—D31:F0)	343
10-2 DMA Registers	361
10-3 PIC Registers (LPC I/F—D31:F0)	372
10-4 APIC Direct Registers (LPC I/F—D31:F0)	380
10-5 APIC Indirect Registers (LPC I/F—D31:F0)	380
10-6 RTC I/O Registers (LPC I/F—D31:F0)	385
10-7 RTC (Standard) RAM Bank (LPC I/F—D31:F0)	386
10-8 Processor Interface PCI Register Address Map (LPC I/F—D31:F0)	390
10-9 Power Management PCI Register Address Map (PM—D31:F0)	393
10-10 APM Register Map	402
10-11 ACPI and Legacy I/O Register Map	403
10-12 TCO I/O Register Address Map	423
10-13 Registers to Control GPIO Address Map	430
11-1 IDE Controller PCI Register Address Map (IDE-D31:F1)	437
11-2 Bus Master IDE I/O Registers	451
12-1 SATA Controller PCI Register Address Map (SATA—D31:F2)	455
12-1 SATA Indexed Registers	475
12-2 Bus Master IDE I/O Register Address Map	483
12-3 AHCI Register Address Map	486
12-4 Generic Host Controller Register Address Map	486
12-5 Port [3:0] DMA Register Address Map	491
13-1 UHCI Controller PCI Register Address Map (USB—D29:F0/F1/F2/F3)	507
13-2 USB I/O Registers	516
13-3 Run/Stop, Debug Bit Interaction SWDBG (Bit 5), Run/Stop (Bit 0) Operation	519
14-1 USB EHCI PCI Register Address Map (USB EHCI—D29:F7)	527
14-2 Enhanced Host Controller Capability Registers	544
14-3 Enhanced Host Controller Operational Register Address Map	547
14-4 Debug Port Register Address Map	560
15-1 SMBus Controller PCI Register Address Map (SMBus—D31:F3)	563
15-2 SMBus I/O Register Address Map	569
16-1 AC '97 Audio PCI Register Address Map (Audio—D30:F2)	581
16-2 Intel® ICH6 Audio Mixer Register Configuration	593
16-3 Native Audio Bus Master Control Registers	594
17-1 AC '97 Modem PCI Register Address Map (Modem—D30:F3)	607

17-2 Intel® ICH6 Modem Mixer Register Configuration	616
17-3 Modem Registers	617
18-1 Intel® High Definition Audio PCI Register Address Map (Intel® High Definition Audio D27:F0)	627
18-2 Intel® High Definition Audio PCI Register Address Map (Intel® High Definition Audio D27:F0)	649
19-1 PCI Express* Configuration Registers Address Map (PCI Express—D28:F0/F1/F2/F3)	675
20-1 Memory-Mapped Registers	716
21-1 Intel® ICH6 Ballout by Signal Name	726
22-1 Intel® ICH6 Absolute Maximum Ratings	733
22-2 DC Current Characteristics	734
22-3 DC Current Characteristics (Mobile Only)	735
22-4 DC Characteristic Input Signal Association	736
22-5 DC Input Characteristics	738
22-6 DC Characteristic Output Signal Association	740
22-7 DC Output Characteristics	741
22-8 Other DC Characteristics	742
22-9 Clock Timings	743
22-10 PCI Interface Timing	745
22-11 IDE PIO Mode Timings	745
22-12 IDE Multiword DMA Timings	746
22-13 Ultra ATA Timing (Mode 0, Mode 1, Mode 2)	747
22-14 Ultra ATA Timing (Mode 3, Mode 4, Mode 5)	749
22-15 Universal Serial Bus Timing	751
22-16 SATA Interface Timings	752
22-17 SMBus Timing	752
22-19 LPC Timing	753
22-20 Miscellaneous Timings	753
22-18 AC '97 / Intel® High Definition Audio Timing	753
22-21 (Power Sequencing and Reset Signal Timings)	754
22-22 Power Management Timings	756
24-1 XOR Test Pattern Example	780
24-2 XOR Chain #1 (REQ[4:1]# = 0000)	781
24-3 XOR Chain #2 (REQ[4:1]# = 0001)	782
24-4 XOR Chain #3 (REQ[4:1]# = 0010)	783
24-5 XOR Chain #4-1 (REQ[4:1]# = 0011)	784
24-6 XOR Chain #4-2 (REQ[4:1]# = 0011)	785
24-7 XOR Chain #5 (REQ[4:1]# = 0100)	786

Revision History

Revision	Description	Date
-001	Initial release.	June 2004
-002	<ul style="list-style-type: none">• Added ICH6-M content• Removed support for Wireless SKUs.• Added all specification clarifications, changes and document changes from Specification Updates.	January 2005

Intel® ICH6 Family Features

- New: Direct Media Interface
 - 10 Gb/s each direction, full duplex
 - Transparent to software
- New: PCI Express*
 - 4 PCI Express root ports
 - Fully PCI Express 1.0a compliant
 - Can be statically configured as 4x1, or 1x4 (Enterprise applications only)
 - Two virtual channel support for full isochronous data transfers
 - Support for full 2.5 Gb/s bandwidth in each direction per x1 lane
 - Module based Hot-Plug supported (e.g., ExpressCard*)
- PCI Bus Interface
 - Supports PCI Rev 2.3 Specification at 33 MHz
 - New: Seven available PCI REQ/GNT pairs
 - Support for 64-bit addressing on PCI using DAC protocol
- New: Integrated Serial ATA Host Controller
 - Four ports (Desktop Only) or two ports (Mobile Only).
 - Data transfer rates up to 1.5 Gb/s (150 MB/s).
 - Integrated AHCI controller (ICH6-M / ICH6R Only)
- Integrated IDE Controller
 - Independent timing of up to two drives
 - Ultra ATA/100/66/33, BMIDE and PIO modes
 - Tri-state modes to enable swap bay
- New: Intel® High Definition Audio Interface
 - PCI Express endpoint
 - Independent Bus Master logic for eight general purpose streams: four input and four output
 - Support three external CODECs
 - Supports variable length stream slots
 - Supports multichannel, 32-bit sample depth, 192 kHz sample rate output
 - Provides mic array support
 - Supports memory-based command/response transport
 - Allows for non-48 kHz sampling output
 - Support for ACPI Device States
- AC-Link for Audio and Telephony CODECs
 - Support for three AC '97 2.3 codecs.
 - Independent bus master logic for 8 channels (PCM In/Out, PCM 2 In, Mic 1 Input, Mic 2 Input, Modem In/Out, S/PDIF Out)
 - Support for up to six channels of PCM audio output (full AC3 decode)
 - Supports wake-up events
- USB 2.0
 - Includes four UHCI Host Controllers, supporting eight external ports
 - Includes one EHCI Host Controller that supports all eight ports
 - Includes one USB 2.0 High-speed Debug Port
 - Supports wake-up from sleeping states S1–S5
 - Supports legacy Keyboard/Mouse software
- Integrated LAN Controller
 - Integrated ASF Management Controller
 - EfM 2.0
 - LAN Connect Interface (LCI)
 - 10/100 Mb/s Ethernet Support
- Power Management Logic
 - ACPI 2.0 compliant
 - ACPI-defined power states (C1, S1, S3–S5 for Desktop and C1–C4, S1, S3–S5 for Mobile)
 - ACPI Power Management Timer
 - (Mobile Only) Support for “Intel SpeedStep® technology” processor power control and “Deeper Sleep” power state
 - PCI CLKRUN# and PME# support
 - SMI# generation
 - All registers readable/restorable for proper resume from 0 V suspend states
 - Support for APM-based legacy power management for non-ACPI Desktop and Mobile implementations
- External Glue Integration
 - Integrated Pull-up, Pull-down and Series Termination resistors on IDE, processor I/F
 - Integrated Pull-down and Series resistors on USB
- Enhanced DMA Controller
 - Two cascaded 8237 DMA controllers
 - Supports LPC DMA

- SMBus
 - New: Flexible SMBus/SMLink architecture to optimize for ASF
 - Provides independent manageability bus through SMLink interface
 - Supports SMBus 2.0 Specification
 - Host interface allows processor to communicate via SMBus
 - Slave interface allows an internal or external Microcontroller to access system resources
 - Compatible with most two-wire components that are also I²C compatible
- High Precision Event Timers
 - Advanced operating system interrupt scheduling
- Timers Based on 82C54
 - System timer, Refresh request, Speaker tone output
- Real-Time Clock
 - 256-byte battery-backed CMOS RAM
 - Integrated oscillator components
 - Lower Power DC/DC Converter implementation
- System TCO Reduction Circuits
 - Timers to generate SMI# and Reset upon detection of system hang
 - Timers to detect improper processor reset
 - Integrated processor frequency strap logic
 - Supports ability to disable external devices
- Interrupt Controller
 - Supports up to eight PCI interrupt pins
 - Supports PCI 2.3 Message Signaled Interrupts
 - Two cascaded 82C59 with 15 interrupts
 - Integrated I/O APIC capability with 24 interrupts
 - Supports Processor System Bus interrupt delivery
- 1.5 V operation with 3.3 V I/O
 - 5 V tolerant buffers on IDE, PCI, and Legacy signals
- Integrated 1.5 V Voltage Regulator (INTVR) for the Suspend and LAN wells
- Integrated 2.5 V Regulator for Vcc2_5
- Firmware Hub I/F supports BIOS Memory size up to 8 Mbytes
- Low Pin Count (LPC) I/F
 - Supports two Master/DMA devices.
 - Support for Security Device (Trusted Platform Module) connected to LPC.
- GPIO
 - TTL, Open-Drain, Inversion
- Package 31x31 mm 609 mBGA

Figure 1. Desktop Configuration

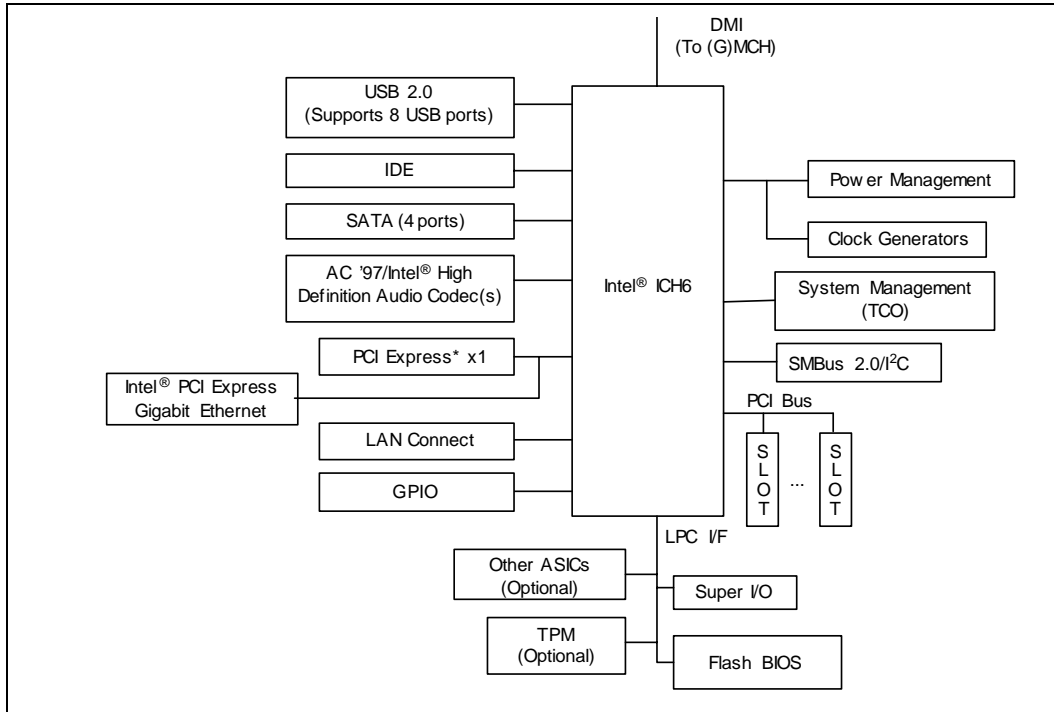
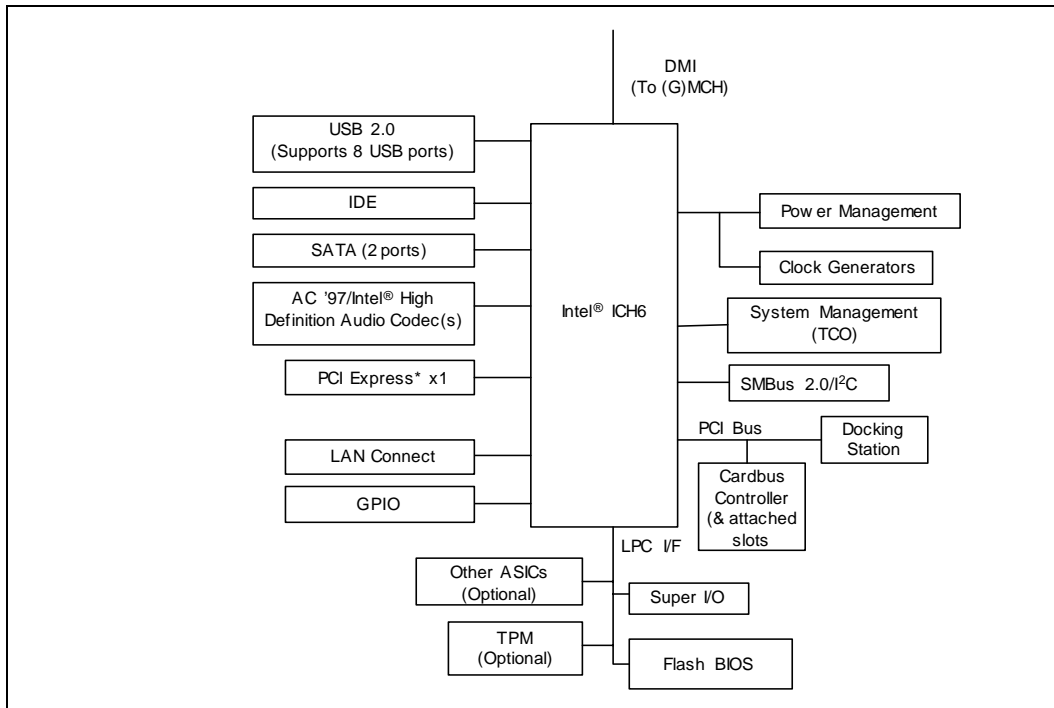

Figure 2. Mobile Configuration



1 Introduction

This document is intended for Original Equipment Manufacturers and BIOS vendors creating Intel® I/O Controller Hub 6 (ICH6) Family (ICH6, ICH6R, and ICH6-M) based products. This document is the datasheet for the following:

- Intel® 82801FB ICH6 (ICH6)
- Intel® 82801FR ICH6 RAID (ICH6R)
- Intel® 82801FBM ICH6 Mobile (ICH6-M)

Note: Throughout this datasheet, ICH6 is used as a general ICH6 term and refers to the 82801FB ICH6, 82801FR ICH6R, and 82801FBM ICH6-M components, unless specifically noted otherwise.

Note: Throughout this datasheet, the term “Desktop” refers to any implementation other than mobile, be it in a desktop, server, workstation, etc., unless specifically noted otherwise. The term “Mobile” refers to implementations using the Intel 82801FBM ICH6 Mobile (ICH6-M).

This datasheet assumes a working knowledge of the vocabulary and principles of PCI Express*, USB, IDE, AHCI, SATA, Intel® High Definition Audio, AC '97, SMBus, PCI, ACPI and LPC. Although some details of these features are described within this datasheet, refer to the individual industry specifications listed in [Table 1-1](#) for the complete details.

Table 1-1. Industry Specifications (Sheet 1 of 2)

Specification	Location
<i>PCI Express* Base Specification, Revision 1.0a</i>	http://www.pcisig.com/specifications
<i>Low Pin Count Interface Specification, Revision 1.1 (LPC)</i>	http://developer.intel.com/design/chipsets/industry/lpc.htm
<i>Audio Codec '97 Component Specification, Version 2.3 (AC '97)</i>	http://www.intel.com/labs/media/audio/index.htm
<i>System Management Bus Specification, Version 2.0 (SMBus)</i>	http://www.smbus.org/specs/
<i>PCI Local Bus Specification, Revision 2.3 (PCI)</i>	http://www.pcisig.com/specifications
<i>PCI Mobile Design Guide, Revision 1.1</i>	http://www.pcisig.com/specifications
<i>PCI Power Management Specification, Revision 1.1</i>	http://www.pcisig.com/specifications
<i>Universal Serial Bus Revision 2.0 Specification (USB)</i>	http://www.usb.org
<i>Advanced Configuration and Power Interface, Version 2.0 (ACPI)</i>	http://www.acpi.info/spec.htm
<i>Universal Host Controller Interface, Revision 1.1 (UHCI)</i>	http://developer.intel.com/design/USB/UHCI11D.htm
<i>Enhanced Host Controller Interface Specification for Universal Serial Bus, Revision 1.0 (EHCI)</i>	http://developer.intel.com/technology/usb/ehcispec.htm
<i>Serial ATA Specification, Revision 1.0a</i>	http://www.serialata.org
<i>Serial ATA II: Extensions to Serial ATA 1.0, Revision 1.0</i>	http://www.serialata.org

Table 1-1. Industry Specifications (Sheet 2 of 2)

Specification	Location
Alert Standard Format Specification, Version 1.03	http://www.dmtf.org/standards/asf
AT Attachment - 6 with Packet Interface (ATA/ATAPI - 6)	http://T13.org (T13 1410D)
IA-PC HPET (High Precision Event Timers) Specification, Revision 0.98a	http://www.intel.com/labs/platcomp/hpet/hpetspec.htm

Chapter 1. Introduction

Chapter 1 introduces the ICH6 and provides information on manual organization and gives a general overview of the ICH6.

Chapter 2. Signal Description

Chapter 2 provides a block diagram of the ICH6/ICH6-M and a detailed description of each signal. Signals are arranged according to interface and details are provided as to the drive characteristics (Input/Output, Open Drain, etc.) of all signals.

Chapter 3. ICH6 Pin States

Chapter 3 provides a complete list of signals, their associated power well, their logic level in each suspend state, and their logic level before and after reset.

Chapter 4. System Clock Domains

Chapter 4 provides a list of each clock domain associated with the ICH6 in an ICH6 based system.

Chapter 5. Functional Description

Chapter 5 provides a detailed description of the functions in the ICH6. All PCI buses, devices and functions in this document are abbreviated using the following nomenclature; Bus:Device:Function. This document abbreviates buses as B0 and B1, devices as D8, D27, D28, D29, D30 and D31 and functions as F0, F1, F2, F3, F4, F5, F6 and F7. For example Device 31 Function 0 is abbreviated as D31:F0, Bus 1 Device 8 Function 0 is abbreviated as B1:D8:F0. Generally, the bus number will not be used, and can be considered to be Bus 0. Note that the ICH6's external PCI bus is typically Bus 1, but may be assigned a different number depending upon system configuration.

Chapter 6. Register and Memory Mappings

Chapter 6 provides an overview of the registers, fixed I/O ranges, variable I/O ranges and memory ranges decoded by the ICH6.

Chapter 7. Chipset Configuration Registers

Chapter 7 provides a detailed description of all registers and base functionality that is related to chipset configuration and not a specific interface (such as LPC, PCI, or PCI Express). It contains the root complex register block, which describes the behavior of the upstream internal link.

Chapter 8. LAN Controller Registers

Chapter 8 provides a detailed description of all registers that reside in the ICH6's integrated LAN controller. The integrated LAN controller resides on the ICH6's external PCI bus (typically Bus 1) at Device 8, Function 0 (B1:D8:F0).

Chapter 9. PCI-to-PCI Bridge Registers

Chapter 9 provides a detailed description of all registers that reside in the PCI-to-PCI bridge. This bridge resides at Device 30, Function 0 (D30:F0).

Chapter 10. LPC Bridge Registers

[Chapter 10](#) provides a detailed description of all registers that reside in the LPC bridge. This bridge resides at Device 31, Function 0 (D31:F0). This function contains registers for many different units within the ICH6 including DMA, Timers, Interrupts, Processor Interface, GPIO, Power Management, System Management and RTC.

Chapter 11. IDE Controller Registers

[Chapter 11](#) provides a detailed description of all registers that reside in the IDE controller. This controller resides at Device 31, Function 1 (D31:F1).

Chapter 12. SATA Controller Registers

[Chapter 12](#) provides a detailed description of all registers that reside in the SATA controller. This controller resides at Device 31, Function 2 (D31:F2).

Chapter 13. UHCI Controller Registers

[Chapter 13](#) provides a detailed description of all registers that reside in the four UHCI host controllers. These controllers reside at Device 29, Functions 0, 1, 2, and 3 (D29:F0/F1/F2/F3).

Chapter 14. EHCI Controller Registers

[Chapter 14](#) provides a detailed description of all registers that reside in the EHCI host controller. This controller resides at Device 29, Function 7 (D29:F7).

Chapter 15. SMBus Controller Registers

[Chapter 15](#) provides a detailed description of all registers that reside in the SMBus controller. This controller resides at Device 31, Function 3 (D31:F3).

Chapter 16. AC '97 Audio Controller Registers

[Chapter 16](#) provides a detailed description of all registers that reside in the audio controller. This controller resides at Device 30, Function 2 (D30:F2). Note that this section of the EDS does not include the native audio mixer registers. Accesses to the mixer registers are forwarded over the AC-link to the codec where the registers reside.

Chapter 17. AC '97 Modem Controller Registers

[Chapter 17](#) provides a detailed description of all registers that reside in the modem controller. This controller resides at Device 30, Function 3 (D30:F3). Note that this section of the EDS does not include the modem mixer registers. Accesses to the mixer registers are forwarded over the AC-link to the codec where the registers reside.

Chapter 18. Intel® High Definition Audio Controller Registers

[Chapter 18](#) provides a detailed description of all registers that reside in the Intel® High Definition Audio controller. This controller resides at Device 27, Function 0 (D27:F0).

Chapter 19. PCI Express* Port Controller Registers

[Chapter 19](#) provides a detailed description of all registers that reside in the PCI Express controller. This controller resides at Device 28, Functions 0 to 3 (D30:F0-F3).

Chapter 20. High Precision Event Timers Registers

[Chapter 20](#) provides a detailed description of all registers that reside in the multimedia timer memory mapped register space.

Chapter 21. Ballout Definition

[Chapter 21](#) provides a table of each signal and its ball assignment in the 609-mBGA package.

Chapter 22. Electrical Characteristics

[Chapter 22](#) provides all AC and DC characteristics including detailed timing diagrams.

Chapter 23. Package Information

Chapter 23 provides drawings of the physical dimensions and characteristics of the 609-mBGA package.

Chapter 24. Testability

Chapter 24 provides detail about the implementation of test modes provided in the ICH6.

1.2 Overview

The ICH6 provides extensive I/O support. Functions and capabilities include:

- *PCI Express* Base Specification, Revision 1.0a*-compliant
- *PCI Local Bus Specification, Revision 2.3*-compliant with support for 33 MHz PCI operations (supports up to seven Req/Gnt pairs).
- ACPI Power Management Logic Support
- Enhanced DMA controller, interrupt controller, and timer functions
- Integrated Serial ATA host controller with independent DMA operation on four ports (ICH6/ICH6R only) or two ports (ICH6-M only) and AHCI support (ICH6R/ICH6-M only).
- Integrated IDE controller supports Ultra ATA100/66/33
- USB host interface with support for eight USB ports; four UHCI host controllers; one EHCI high-speed USB 2.0 Host controller
- Integrated LAN controller
- *System Management Bus (SMBus) Specification, Version 2.0* with additional support for I²C devices
- Supports *Audio Codec '97, Revision 2.3 Specification* (a.k.a., *AC '97 Component Specification, Revision 2.3*) which provides a link for Audio and Telephony codecs (up to 7 channels)
- Supports Intel High Definition Audio
- Low Pin Count (LPC) interface
- Firmware Hub (FWH) interface support

The ICH6 incorporates a variety of PCI functions that are divided into six logical devices (B0:D27, B0:D28, B0:D29, B0:D30, B0:D31 and B1:D8). D30 is the DMI-to-PCI bridge and the AC '97 Audio and Modem controller functions, D31 contains the PCI-to-LPC bridge, IDE controller, SATA controller, and SMBus controller, D29 contains the four USB UHCI controllers and one USB EHCI controller, and D27 contains the PCI Express root ports. B1:D8 is the integrated LAN controller.

Table 1-2. PCI Devices and Functions

Bus:Device:Function	Function Description
Bus 0:Device 30:Function 0	PCI-to-PCI Bridge
Bus 0:Device 30:Function 2	AC '97 Audio Controller
Bus 0:Device 30:Function 3	AC '97 Modem Controller
Bus 0:Device 31:Function 0	LPC Controller ¹
Bus 0:Device 31:Function 1	IDE Controller
Bus 0:Device 31:Function 2	SATA Controller
Bus 0:Device 31:Function 3	SMBus Controller
Bus 0:Device 29:Function 0	USB UHCI Controller 1
Bus 0:Device 29:Function 1	USB UHCI Controller 2
Bus 0:Device 29:Function 2	USB UHCI Controller 3
Bus 0:Device 29:Function 3	USB UHCI Controller 4
Bus 0:Device 29:Function 7	USB 2.0 EHCI Controller
Bus 0:Device 28:Function 0	PCI Express* Port 1
Bus 0:Device 28:Function 1	PCI Express Port 2
Bus 0:Device 28:Function 2	PCI Express Port 3
Bus 0:Device 28:Function 3	PCI Express Port 4
Bus 0:Device 27:Function 0	Intel High Definition Audio Controller
Bus n:Device 8:Function 0	LAN Controller

NOTES:

1. The PCI-to-LPC bridge contains registers that control LPC, Power Management, System Management, GPIO, Processor Interface, RTC, Interrupts, Timers, and DMA.

The following sub-sections provide an overview of the ICH6 capabilities.

Direct Media Interface (DMI)

Direct Media Interface (DMI) is the chip-to-chip connection between the Memory Controller Hub / Graphics Memory Controller Hub ((G)MCH) and I/O Controller Hub 6 (ICH6). This high-speed interface integrates advanced priority-based servicing allowing for concurrent traffic and true isochronous transfer capabilities. Base functionality is completely software-transparent, permitting current and legacy software to operate normally.

PCI Express* Interface

The ICH6 provides 4 PCI Express root ports that are compliant to the *PCI Express Base Specification, Revision 1.0a*. The PCI Express root ports can be statically configured as four x1 ports or ganged together to form one x4 port (Enterprise applications only). Each Root Port supports 2.5 Gb/s bandwidth in each direction (5 Gb/s concurrent) and two virtual channels for full isochronous data support.

Serial ATA (SATA) Controller

The ICH6 has an integrated SATA host controller that supports independent DMA operation on four ports (desktop only) or two ports (mobile only) and supports data transfer rates of up to 1.5 Gb/s (150 MB/s). The SATA controller contains two modes of operation; a legacy mode using I/O space, and an AHCI mode using memory space (ICH6R/ICH6-M only).

SATA and PATA can also be used in a combined function mode (where the SATA function is used with PATA). In this combined function mode, AHCI mode is not used. Software that uses legacy mode will not have AHCI capabilities.

The ICH6 supports the *Serial ATA Specification, Revision 1.0a*. The ICH6 also supports several optional sections of the *Serial ATA II: Extensions to Serial ATA 1.0 Specification, Revision 1.0* (AHCI support is required for some elements).

AHCI (Intel® ICH6R/ICH6-M only)

The ICH6R/ICH6-M provide hardware support for Advanced Host Controller Interface (AHCI), a new programming interface for SATA host controllers. Platforms supporting AHCI may take advantage of performance features such as no master/slave designation for SATA devices—each device is treated as a master—and hardware-assisted native command queuing. AHCI also provides usability enhancements (e.g., Hot-Plug). AHCI requires appropriate software support (e.g., an AHCI driver) and for some features, hardware support in the SATA device or additional platform hardware.

PCI Interface

The ICH6 PCI interface provides a 33 MHz, Revision 2.3 implementation. All PCI signals are 5 V tolerant, except PME#. The ICH6 integrates a PCI arbiter that supports up to seven external PCI bus masters in addition to the internal ICH6 requests. This allows for combinations of up to seven PCI down devices and PCI slots.

IDE Interface (Bus Master Capability and Synchronous DMA Mode)

The fast IDE interface supports up to two IDE devices providing an interface for IDE hard disks and ATAPI devices. Each IDE device can have independent timings. The IDE interface supports PIO IDE transfers up to 16 MB/sec and Ultra ATA transfers up to 100 MB/sec. It does not consume any legacy DMA resources. The IDE interface integrates 16x32-bit buffers for optimal transfers.

The ICH6's IDE system contains a single, independent IDE signal channel that can be electrically isolated. There are integrated series resistors on the data and control lines (see [Section 5.16](#) for details).

Low Pin Count (LPC) Interface

The ICH6 implements an LPC Interface as described in the LPC 1.1 specification. The Low Pin Count (LPC) bridge function of the ICH6 resides in PCI Device 31:Function 0. In addition to the LPC bridge interface function, D31:F0 contains other functional units including DMA, interrupt controllers, timers, power management, system management, GPIO, and RTC.

Compatibility Modules (DMA Controller, Timer/Counters, Interrupt Controller)

The DMA controller incorporates the logic of two 82C37 DMA controllers, with seven independently programmable channels. Channels 0–3 are hardwired to 8-bit, count-by-byte transfers, and channels 5–7 are hardwired to 16-bit, count-by-word transfers. Any two of the seven DMA channels can be programmed to support fast Type-F transfers.

The ICH6 supports LPC DMA, which is similar to ISA DMA, through the ICH6's DMA controller. LPC DMA is handled through the use of the LDRQ# lines from peripherals and special encoding on LAD[3:0] from the host. Single, Demand, Verify, and Increment modes are supported on the LPC interface. Channels 0–3 are 8-bit channels. Channels 5–7 are 16-bit channels. Channel 4 is reserved as a generic bus master request.

The timer/counter block contains three counters that are equivalent in function to those found in one 82C54 programmable interval timer. These three counters are combined to provide the system timer function, and speaker tone. The 14.31818 MHz oscillator input provides the clock source for these three counters.

The ICH6 provides an ISA-Compatible Programmable Interrupt Controller (PIC) that incorporates the functionality of two, 82C59 interrupt controllers. The two interrupt controllers are cascaded so that 14 external and two internal interrupts are possible. In addition, the ICH6 supports a serial interrupt scheme.

All of the registers in these modules can be read and restored. This is required to save and restore system state after power has been removed and restored to the platform.

Advanced Programmable Interrupt Controller (APIC)

In addition to the standard ISA compatible Programmable Interrupt controller (PIC) described in the previous section, the ICH6 incorporates the Advanced Programmable Interrupt Controller (APIC).

Universal Serial Bus (USB) Controller

The ICH6 contains an Enhanced Host Controller Interface (EHCI) compliant host controller that supports USB high-speed signaling. High-speed USB 2.0 allows data transfers up to 480 Mb/s which is 40 times faster than full-speed USB. The ICH6 also contains four Universal Host Controller Interface (UHCI) controllers that support USB full-speed and low-speed signaling.

The ICH6 supports eight USB 2.0 ports. All eight ports are high-speed, full-speed, and low-speed capable. ICH6's port-routing logic determines whether a USB port is controlled by one of the UHCI controllers or by the EHCI controller. See [Section 5.19](#) and [Section 5.20](#) for details.

LAN Controller

The ICH6's integrated LAN controller includes a 32-bit PCI controller that provides enhanced scatter-gather bus mastering capabilities and enables the LAN controller to perform high speed data transfers over the PCI bus. Its bus master capabilities enable the component to process high-level commands and perform multiple operations; this lowers processor utilization by off-loading communication tasks from the processor. Two large transmit and receive FIFOs of 3 KB each help prevent data underruns and overruns while waiting for bus accesses. This enables the integrated LAN controller to transmit data with minimum interframe spacing (IFS).

The LAN controller can operate in either full duplex or half duplex mode. In full duplex mode the LAN controller adheres with the IEEE 802.3x Flow Control specification. Half duplex performance is enhanced by a proprietary collision reduction mechanism. See [Section 5.3](#) for details.

Alert Standard Format (ASF) Management Controller

ICH6 integrates an Alert Stand Format controller in addition to the integrated LAN controller, allowing interface system-monitoring devices to communicate through the integrated LAN controller to the network. This means remote manageability and system hardware monitoring are made possible using ASF.

The ASF controller can collect and send various information from system components such as the processor, chipset, BIOS and sensors on the motherboard to a remote server running a management console. The controller can also be programmed to accept commands back from the management console and execute those commands on the local system.

RTC

The ICH6 contains a Motorola MC146818A-compatible real-time clock with 256 bytes of battery-backed RAM. The real-time clock performs two key functions: keeping track of the time of day and storing system data, even when the system is powered down. The RTC operates on a 32.768 KHz crystal and a 3 V battery.

The RTC also supports two lockable memory ranges. By setting bits in the configuration space, two 8-byte ranges can be locked to read and write accesses. This prevents unauthorized reading of passwords or other system security information.

The RTC also supports a date alarm that allows for scheduling a wake up event up to 30 days in advance, rather than just 24 hours in advance.

GPIO

Various general purpose inputs and outputs are provided for custom system design. The number of inputs and outputs varies depending on ICH6 configuration.

Enhanced Power Management

The ICH6's power management functions include enhanced clock control and various low-power (suspend) states (e.g., Suspend-to-RAM and Suspend-to-Disk). A hardware-based thermal management circuit permits software-independent entrance to low-power states. The ICH6 contains full support for the *Advanced Configuration and Power Interface (ACPI) Specification, Revision 2.0*.

Manageability

The ICH6 integrates several functions designed to manage the system and lower the total cost of ownership (TCO) of the system. These system management functions are designed to report errors, diagnose the system, and recover from system lockups without the aid of an external microcontroller.

- **TCO Timer.** The ICH6's integrated programmable TCO timer is used to detect system locks. The first expiration of the timer generates an SMI# that the system can use to recover from a software lock. The second expiration of the timer causes a system reset to recover from a hardware lock.
- **Processor Present Indicator.** The ICH6 looks for the processor to fetch the first instruction after reset. If the processor does not fetch the first instruction, the ICH6 will reboot the system.
- **ECC Error Reporting.** When detecting an ECC error, the host controller has the ability to send one of several messages to the ICH6. The host controller can instruct the ICH6 to generate either an SMI#, NMI, SERR#, or TCO interrupt.
- **Function Disable.** The ICH6 provides the ability to disable the following integrated functions: AC '97 Modem, AC '97 Audio, IDE, LAN, USB, LPC, Intel High Definition Audio, SATA, or SMBus. Once disabled, these functions no longer decode I/O, memory, or PCI configuration space. Also, no interrupts or power management events are generated from the disable functions.
- **Intruder Detect.** The ICH6 provides an input signal (INTRUDER#) that can be attached to a switch that is activated by the system case being opened. The ICH6 can be programmed to generate an SMI# or TCO interrupt due to an active INTRUDER# signal.
- **SMBus 2.0.** The ICH6 integrates an SMBus controller that provides an interface to manage peripherals (e.g., serial presence detection (SPD) and thermal sensors) with host notify capabilities.

System Management Bus (SMBus 2.0)

The ICH6 contains an SMBus Host interface that allows the processor to communicate with SMBus slaves. This interface is compatible with most I²C devices. Special I²C commands are implemented.

The ICH6's SMBus host controller provides a mechanism for the processor to initiate communications with SMBus peripherals (slaves). Also, the ICH6 supports slave functionality, including the Host Notify protocol. Hence, the host controller supports eight command protocols of the SMBus interface (see *System Management Bus (SMBus) Specification, Version 2.0*): Quick Command, Send Byte, Receive Byte, Write Byte/Word, Read Byte/Word, Process Call, Block Read/Write, and Host Notify.

ICH6's SMBus also implements hardware-based Packet Error Checking for data robustness and the Address Resolution Protocol (ARP) to dynamically provide address to all SMBus devices.

Intel High Definition Audio Controller

The Intel High Definition Audio specification defines a digital interface that can be used to attach different types of codecs, such as audio and modem codecs. The ICH6 Intel High Definition Audio digital link shares pins with the AC-link. Concurrent operation of Intel High Definition Audio and AC '97 functionality is not supported. The ICH6 Intel High Definition Audio controller supports up to 3 codecs.

With the support of multi-channel audio stream, 32-bit sample depth, and sample rate up to 192 kHz, the Intel High Definition Audio controller provides audio quality that can deliver CE levels of audio experience. On the input side, the ICH6 adds support for an arrays of microphones.

The Intel High Definition Audio controller utilizes multi-purpose DMA engines, as opposed to dedicated DMA engines in AC '97, to effectively manage the link bandwidth and support simultaneous independent streams on the link. The capability enables new exciting usage models with Intel High Definition Audio (e.g., listening to music while playing multi-player game on the internet.) The Intel High Definition Audio controller also supports isochronous data transfers allowing glitch-free audio to the system.

Note: Users interested in providing feedback on the Intel High Definition Audio specification or planning to implement the Intel High Definition Audio specification into a future product will need to execute the Intel High Definition Audio Specification Developer's Agreement. For more information, contact nextgenaudio@intel.com.

AC '97 2.3 Controller

The ICH6 integrates an Audio Codec '97 Component Specification, Version 2.3 controller that can be used to attach an audio codec (AC), a modem codec (MC), an audio/modem codec (AMC) or a combination of ACs and a single MC. The ICH6 supports up to six channels of PCM audio output (full AC3 decode). For a complete surround-sound experience, six-channel audio consists of: front left, front right, back left, back right, center, and subwoofer. ICH6 has expanded support for up to three audio codecs on the AC-link.

In addition, an AC '97 soft modem can be implemented with the use of a modem codec. Several system options exist when implementing AC '97. The ICH6-integrated AC '97 controller allows up to three external codecs to be connected to the ICH6. The system designer can provide AC '97 modem with a modem codec, or both audio and modem with up to two audio codecs with a modem codec.

§

2 Signal Description

This chapter provides a detailed description of each signal. The signals are arranged in functional groups according to their associated interface.

The “#” symbol at the end of the signal name indicates that the active, or asserted state occurs when the signal is at a low voltage level. When “#” is not present, the signal is asserted when at the high voltage level.

The following notations are used to describe the signal type:

I	Input Pin
O	Output Pin
OD O	Open Drain Output Pin.
OD I	Open Drain Input Pin.
OD I/O	Open Drain Input/Output Pin.
OC O	Open Collector Output Pin.
I/O	Bi-directional Input / Output Pin.

Figure 2-1. Intel® ICH6 Interface Signals Block Diagram (Desktop)

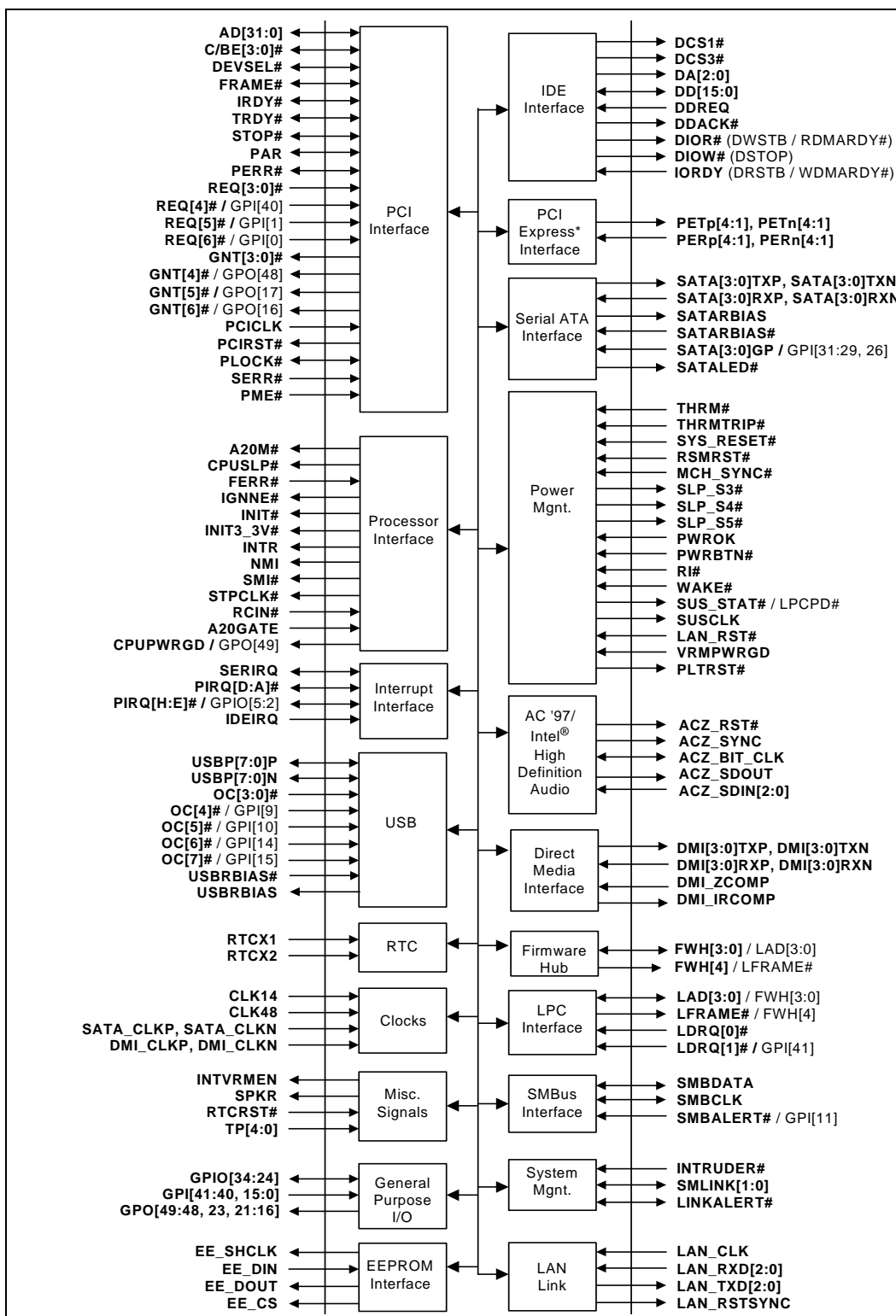
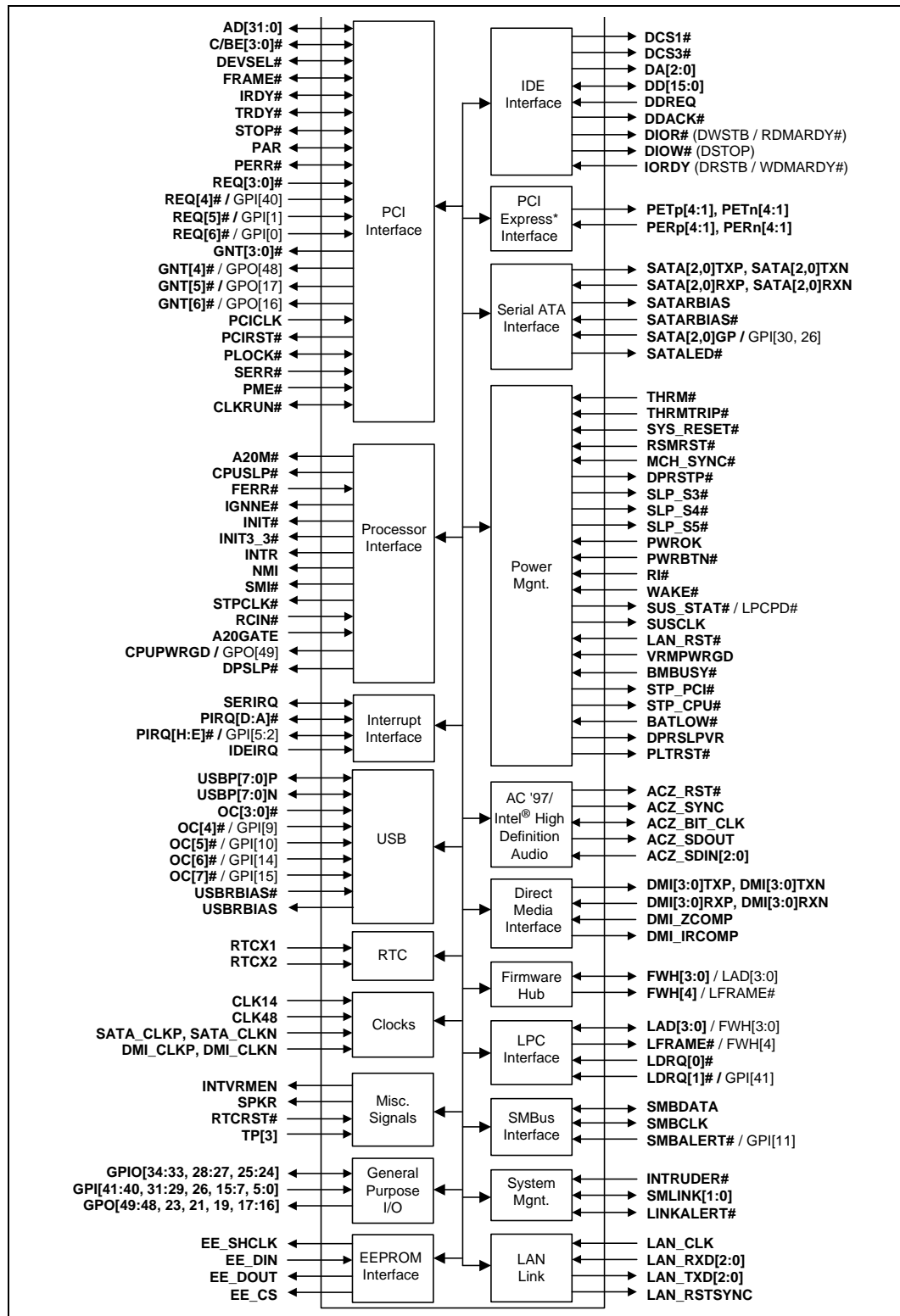

Figure 2-2. Intel® ICH6-M Interface Signals Block Diagram (Mobile Only)



2.1 Direct Media Interface (DMI) to Host Controller

Table 2-1. Direct Media Interface Signals

Name	Type	Description
DMI[0]TXP, DMI[0]TXN	○	Direct Media Interface Differential Transmit Pair 0
DMI[0]RXP, DMI[0]RXN		Direct Media Interface Differential Receive Pair 0
DMI[1]TXP, DMI[1]TXN	○	Direct Media Interface Differential Transmit Pair 1
DMI[1]RXP, DMI[1]RXN		Direct Media Interface Differential Receive Pair 1
DMI[2]TXP, DMI[2]TXN	○	Direct Media Interface Differential Transmit Pair 2
DMI[2]RXP, DMI[2]RXN		Direct Media Interface Differential Receive Pair 2
DMI[3]TXP, DMI[3]TXN	○	Direct Media Interface Differential Transmit Pair 3
DMI[3]RXP, DMI[3]RXN		Direct Media Interface Differential Receive Pair 3
DMI_ZCOMP		Impedance Compensation Input: Determines DMI input impedance.
DMI_IRCOMP	○	Impedance/Current Compensation Output: Determines DMI output impedance and bias current.

2.2 PCI Express*

Table 2-2. PCI Express* Signals

Name	Type	Description
PETp[1], PETn[1]	○	PCI Express* Differential Transmit Pair 1
PERp[1], PERn[1]		PCI Express Differential Receive Pair 1
PETp[2], PETn[2]	○	PCI Express Differential Transmit Pair 2
PERp[2], PERn[2]		PCI Express Differential Receive Pair 2
PETp[3], PETn[3]	○	PCI Express Differential Transmit Pair 3
PERp[3], PERn[3]		PCI Express Differential Receive Pair 3
PETp[4], PETn[4]	○	PCI Express Differential Transmit Pair 4
PERp[4], PERn[4]		PCI Express Differential Receive Pair 4

2.3 Link to LAN Connect

Table 2-3. LAN Connect Interface Signals

Name	Type	Description
LAN_CLK	I	LAN I/F Clock: This signal is driven by the LAN Connect component. The frequency range is 5 MHz to 50 MHz.
LAN_RXD[2:0]	I	Received Data: The LAN Connect component uses these signals to transfer data and control information to the integrated LAN controller. These signals have integrated weak pull-up resistors.
LAN_TXD[2:0]	O	Transmit Data: The integrated LAN controller uses these signals to transfer data and control information to the LAN Connect component.
LAN_RSTSYNC	O	LAN Reset/Sync: The LAN Connect component's Reset and Sync signals are multiplexed onto this pin.

2.4 EEPROM Interface

Table 2-4. EEPROM Interface Signals

Name	Type	Description
EE_SHCLK	O	EEPROM Shift Clock: Serial shift clock output to the EEPROM.
EE_DIN	I	EEPROM Data In: Transfers data from the EEPROM to the Intel® ICH6. This signal has an integrated pull-up resistor.
EE_DOUT	O	EEPROM Data Out: Transfers data from the ICH6 to the EEPROM.
EE_CS	O	EEPROM Chip Select: Chip select signal to the EEPROM.

2.5 Firmware Hub Interface

Table 2-5. Firmware Hub Interface Signals

Name	Type	Description
FWH[3:0] / LAD[3:0]	I/O	Firmware Hub Signals. These signals are multiplexed with the LPC address signals.
FWH[4] / LFRAME#	O	Firmware Hub Signals. This signal is multiplexed with the LPC LFRAME# signal.

2.6 PCI Interface

Table 2-6. PCI Interface Signals (Sheet 1 of 3)

Name	Type	Description																								
AD[31:0]	I/O	PCI Address/Data: AD[31:0] is a multiplexed address and data bus. During the first clock of a transaction, AD[31:0] contain a physical address (32 bits). During subsequent clocks, AD[31:0] contain data. The Intel [®] ICH6 will drive all 0's on AD[31:0] during the address phase of all PCI Special Cycles.																								
C/BE[3:0]#	I/O	<p>Bus Command and Byte Enables: The command and byte enable signals are multiplexed on the same PCI pins. During the address phase of a transaction, C/BE[3:0]# define the bus command. During the data phase C/BE[3:0]# define the Byte Enables.</p> <table border="1"> <thead> <tr> <th>C/BE[3:0]#</th> <th>Command Type</th> </tr> </thead> <tbody> <tr> <td>0000b</td> <td>Interrupt Acknowledge</td> </tr> <tr> <td>0001b</td> <td>Special Cycle</td> </tr> <tr> <td>0010b</td> <td>I/O Read</td> </tr> <tr> <td>0011b</td> <td>I/O Write</td> </tr> <tr> <td>0110b</td> <td>Memory Read</td> </tr> <tr> <td>0111b</td> <td>Memory Write</td> </tr> <tr> <td>1010b</td> <td>Configuration Read</td> </tr> <tr> <td>1011b</td> <td>Configuration Write</td> </tr> <tr> <td>1100b</td> <td>Memory Read Multiple</td> </tr> <tr> <td>1110b</td> <td>Memory Read Line</td> </tr> <tr> <td>1111b</td> <td>Memory Write and Invalidate</td> </tr> </tbody> </table> <p>All command encodings not shown are reserved. The ICH6 does not decode reserved values, and therefore will not respond if a PCI master generates a cycle using one of the reserved values.</p>	C/BE[3:0]#	Command Type	0000b	Interrupt Acknowledge	0001b	Special Cycle	0010b	I/O Read	0011b	I/O Write	0110b	Memory Read	0111b	Memory Write	1010b	Configuration Read	1011b	Configuration Write	1100b	Memory Read Multiple	1110b	Memory Read Line	1111b	Memory Write and Invalidate
C/BE[3:0]#	Command Type																									
0000b	Interrupt Acknowledge																									
0001b	Special Cycle																									
0010b	I/O Read																									
0011b	I/O Write																									
0110b	Memory Read																									
0111b	Memory Write																									
1010b	Configuration Read																									
1011b	Configuration Write																									
1100b	Memory Read Multiple																									
1110b	Memory Read Line																									
1111b	Memory Write and Invalidate																									
DEVSEL#	I/O	Device Select: The ICH6 asserts DEVSEL# to claim a PCI transaction. As an output, the ICH6 asserts DEVSEL# when a PCI master peripheral attempts an access to an internal ICH6 address or an address destined DMI (main memory or graphics). As an input, DEVSEL# indicates the response to an ICH6-initiated transaction on the PCI bus. DEVSEL# is tri-stated from the leading edge of PLTRST#. DEVSEL# remains tri-stated by the ICH6 until driven by a target device.																								
FRAME#	I/O	Cycle Frame: The current initiator drives FRAME# to indicate the beginning and duration of a PCI transaction. While the initiator asserts FRAME#, data transfers continue. When the initiator negates FRAME#, the transaction is in the final data phase. FRAME# is an input to the ICH6 when the ICH6 is the target, and FRAME# is an output from the ICH6 when the ICH6 is the initiator. FRAME# remains tri-stated by the ICH6 until driven by an initiator.																								
IRDY#	I/O	Initiator Ready: IRDY# indicates the ICH6's ability, as an initiator, to complete the current data phase of the transaction. It is used in conjunction with TRDY#. A data phase is completed on any clock both IRDY# and TRDY# are sampled asserted. During a write, IRDY# indicates the ICH6 has valid data present on AD[31:0]. During a read, it indicates the ICH6 is prepared to latch data. IRDY# is an input to the ICH6 when the ICH6 is the target and an output from the ICH6 when the ICH6 is an initiator. IRDY# remains tri-stated by the ICH6 until driven by an initiator.																								

Table 2-6. PCI Interface Signals (Sheet 2 of 3)

Name	Type	Description
TRDY#	I/O	Target Ready: TRDY# indicates the ICH6's ability as a target to complete the current data phase of the transaction. TRDY# is used in conjunction with IRDY#. A data phase is completed when both TRDY# and IRDY# are sampled asserted. During a read, TRDY# indicates that the ICH6, as a target, has placed valid data on AD[31:0]. During a write, TRDY# indicates the ICH6, as a target is prepared to latch data. TRDY# is an input to the ICH6 when the ICH6 is the initiator and an output from the ICH6 when the ICH6 is a target. TRDY# is tri-stated from the leading edge of PLTRST#. TRDY# remains tri-stated by the ICH6 until driven by a target.
STOP#	I/O	Stop: STOP# indicates that the ICH6, as a target, is requesting the initiator to stop the current transaction. STOP# causes the ICH6, as an initiator, to stop the current transaction. STOP# is an output when the ICH6 is a target and an input when the ICH6 is an initiator.
PAR	I/O	Calculated/Checked Parity: PAR uses "even" parity calculated on 36 bits, AD[31:0] plus C/BE[3:0]#. "Even" parity means that the ICH6 counts the number of one within the 36 bits plus PAR and the sum is always even. The ICH6 always calculates PAR on 36 bits regardless of the valid byte enables. The ICH6 generates PAR for address and data phases and only guarantees PAR to be valid one PCI clock after the corresponding address or data phase. The ICH6 drives and tri-states PAR identically to the AD[31:0] lines except that the ICH6 delays PAR by exactly one PCI clock. PAR is an output during the address phase (delayed one clock) for all ICH6 initiated transactions. PAR is an output during the data phase (delayed one clock) when the ICH6 is the initiator of a PCI write transaction, and when it is the target of a read transaction. ICH6 checks parity when it is the target of a PCI write transaction. If a parity error is detected, the ICH6 will set the appropriate internal status bits, and has the option to generate an NMI# or SMI#.
PERR#	I/O	Parity Error: An external PCI device drives PERR# when it receives data that has a parity error. The ICH6 drives PERR# when it detects a parity error. The ICH6 can either generate an NMI# or SMI# upon detecting a parity error (either detected internally or reported via the PERR# signal).
REQ[0:3]# REQ[4]# / GPI[40] REQ[5]# / GPI[1] REQ[6]# / GPI[0]	I	PCI Requests: The ICH6 supports up to 7 masters on the PCI bus. The REQ[4]#, REQ[5]#, and REQ[6]# pins can instead be used as a GPI.
GNT[0:3]# GNT[4]# / GPO[48] GNT[5]# / GPO[17]# GNT[6]# / GPO[16]#	O	PCI Grants: The ICH6 supports up to 7 masters on the PCI bus. The GNT[4]# pin can instead be used as a GPO. Pull-up resistors are not required on these signals. If pull-ups are used, they should be tied to the Vcc3_3 power rail. GNT[5]#/GPO[17] and GNT[6]#/GPO[17] both have an internal pull-up. NOTE: GNT[6] is sampled at the rising edge of PWROK as a functional strap. See Section 2.22.1 for more details. There is a weak, integrated pull-up resistor on the GNT[6] pin.
PCICLK	I	PCI Clock: This is a 33 MHz clock. PCICLK provides timing for all transactions on the PCI Bus. NOTE: (Mobile Only) This clock does not stop based on STP_PCI# signal. PCI Clock only stops based on SLP_S3#.
PCIRST#	O	PCI Reset: This is the Secondary PCI Bus reset signal. It is a logical OR of the primary interface PLTRST# signal and the state of the Secondary Bus Reset bit of the Bridge Control register (D30:F0:3Eh, bit 6). NOTE: PCIRST# is in the VccSus3_3 well.

Table 2-6. PCI Interface Signals (Sheet 3 of 3)

Name	Type	Description
PLOCK#	I/O	PCI Lock: This signal indicates an exclusive bus operation and may require multiple transactions to complete. ICH6 asserts PLOCK# when it performs non-exclusive transactions on the PCI bus. PLOCK# is ignored when PCI masters are granted the bus in desktop configurations. Devices on the PCI bus (other than the ICH6) are not permitted to assert the PLOCK# signal in mobile configurations.
SERR#	OD I/O	System Error: SERR# can be pulsed active by any PCI device that detects a system error condition. Upon sampling SERR# active, the ICH6 has the ability to generate an NMI, SMI#, or interrupt.
PME#	OD I	PCI Power Management Event: PCI peripherals drive PME# to wake the system from low-power states S1–S5. PME# assertion can also be enabled to generate an SCI from the S0 state. In some cases the ICH6 may drive PME# active due to an internal wake event. The ICH6 will not drive PME# high, but it will be pulled up to VccSus3_3 by an internal pull-up resistor.
CLKRUN# (Mobile Only) / GPIO[32] (Desktop Only)	I/O	PCI Clock Run: This signal is used to support PCI Clock Run protocol. It connects to PCI devices that need to request clock re-start, or prevention of clock stopping. NOTE: An external pull-up to Vcc3_3 is required.

2.7 Serial ATA Interface

Table 2-7. Serial ATA Interface Signals (Sheet 1 of 2)

Name	Type	Description
SATA[0]TXP SATA[0]TXN	O	Serial ATA 0 Differential Transmit Pair: These are outbound high-speed differential signals to Port 0.
SATA[0]RXP SATA[0]RXN	I	Serial ATA 0 Differential Receive Pair: These are inbound high-speed differential signals from Port 0.
SATA[1]TXP SATA[1]TXN	O	Serial ATA 1 Differential Transmit Pair: These are outbound high-speed differential signals to Port 1. (Desktop Only)
SATA[1]RXP SATA[1]RXN	I	Serial ATA 1 Differential Receive Pair: These are inbound high-speed differential signals from Port 1. (Desktop Only)
SATA[2]TXP SATA[2]TXN	O	Serial ATA 2 Differential Transmit Pair: These are outbound high-speed differential signals to Port 2.
SATA[2]RXP SATA[2]RXN	I	Serial ATA 2 Differential Receive Pair: These are inbound high-speed differential signals from Port 2.
SATA[3]TXP SATA[3]TXN	O	Serial ATA 3 Differential Transmit Pair: These are outbound high-speed differential signals to Port 3. (Desktop Only)
SATA[3]RXP SATA[3]RXN	I	Serial ATA 3 Differential Receive Pair: These are inbound high-speed differential signals from Port 3. (Desktop Only)
SATARBIAS	O	Serial ATA Resistor Bias: These are analog connection points for an external resistor to ground.
SATARBIAS#	I	Serial ATA Resistor Bias Complement: These are analog connection points for an external resistor to ground.

Table 2-7. Serial ATA Interface Signals (Sheet 2 of 2)

Name	Type	Description
SATA[0]GP / GPI[26]	I	<p>Serial ATA 0 General Purpose: This is an input pin that can be configured as an interlock switch corresponding to SATA Port 0. When used as an interlock switch status indication, this signal should be drive to 0 to indicate that the switch is closed and to 1 to indicate that the switch is open.</p> <p>If interlock switches are not required, this pin can be configured as GPI[26].</p> <p>NOTE: All SATAxGP pins must be configured with the same function: as either SATAxGP pins or GPI pins.</p>
SATA[1]GP (Desktop Only) / GPI[29]	I	<p>Serial ATA 1 General Purpose: Same function as SATA[0]GP, except for SATA Port 1.</p> <p>If interlock switches are not required, this pin can be configured as GPI[29].</p>
SATA[2]GP / GPI[30]	I	<p>Serial ATA 2 General Purpose: Same function as SATA[0]GP, except for SATA Port 2.</p> <p>If interlock switches are not required, this pin can be configured as GPI[30].</p>
SATA[3]GP (Desktop Only) / GPI[31]	I	<p>Serial ATA 3 General Purpose: Same function as SATA[0]GP, except for SATA Port 3.</p> <p>If interlock switches are not required, this pin can be configured as GPI[31].</p>
SATALED#	OC O	<p>Serial ATA LED: This is an open-collector output pin driven during SATA command activity. It is to be connected to external circuitry that can provide the current to drive a platform LED. When active, the LED is on. When tri-stated, the LED is off. An external pull-up resistor to Vcc3_3 is required.</p> <p>NOTE: An internal pull-up is enabled only during PLTRST# assertion.</p>

2.8 IDE Interface

Table 2-8. IDE Interface Signals (Sheet 1 of 2)

Name	Type	Description
DCS1#	O	<p>IDE Device Chip Selects for 100 Range: For ATA command register block. This output signal is connected to the corresponding signal on the IDE connector.</p>
DCS3#	O	<p>IDE Device Chip Select for 300 Range: For ATA control register block. This output signal is connected to the corresponding signal on the IDE connector.</p>
DA[2:0]	O	<p>IDE Device Address: These output signals are connected to the corresponding signals on the IDE connector. They are used to indicate which byte in either the ATA command block or control block is being addressed.</p>
DD[15:0]	I/O	<p>IDE Device Data: These signals directly drive the corresponding signals on the IDE connector. There is a weak internal pull-down resistor on DD7.</p>
DDREQ	I	<p>IDE Device DMA Request: This input signal is directly driven from the DRQ signal on the IDE connector. It is asserted by the IDE device to request a data transfer, and used in conjunction with the PCI bus master IDE function and are not associated with any AT compatible DMA channel. There is a weak internal pull-down resistor on this signal.</p>
DDACK#	O	<p>IDE Device DMA Acknowledge: This signal directly drives the DAK# signal on the IDE connector. DDACK# is asserted by the Intel[®] ICH6 to indicate to IDE DMA slave devices that a given data transfer cycle (assertion of DIOR# or DIOW#) is a DMA data transfer cycle. This signal is used in conjunction with the PCI bus master IDE function and are not associated with any AT-compatible DMA channel.</p>

Table 2-8. IDE Interface Signals (Sheet 2 of 2)

Name	Type	Description
DIOR# / (DWSTB / RDMARDY#)	O	<p>Disk I/O Read (PIO and Non-Ultra DMA): This is the command to the IDE device that it may drive data onto the DD lines. Data is latched by the ICH6 on the de-assertion edge of DIOR#. The IDE device is selected either by the ATA register file chip selects (DCS1# or DCS3#) and the DA lines, or the IDE DMA acknowledge (DDAK#).</p> <p>Disk Write Strobe (Ultra DMA Writes to Disk): This is the data write strobe for writes to disk. When writing to disk, ICH6 drives valid data on rising and falling edges of DWSTB.</p> <p>Disk DMA Ready (Ultra DMA Reads from Disk): This is the DMA ready for reads from disk. When reading from disk, ICH6 de-asserts RDMARDY# to pause burst data transfers.</p>
DIOW# / (DSTOP)	O	<p>Disk I/O Write (PIO and Non-Ultra DMA): This is the command to the IDE device that it may latch data from the DD lines. Data is latched by the IDE device on the de-assertion edge of DIOW#. The IDE device is selected either by the ATA register file chip selects (DCS1# or DCS3#) and the DA lines, or the IDE DMA acknowledge (DDAK#).</p> <p>Disk Stop (Ultra DMA): ICH6 asserts this signal to terminate a burst.</p>
IORDY / (DRSTB / WDMARDY#)	I	<p>I/O Channel Ready (PIO): This signal will keep the strobe active (DIOR# on reads, DIOW# on writes) longer than the minimum width. It adds wait-states to PIO transfers.</p> <p>Disk Read Strobe (Ultra DMA Reads from Disk): When reading from disk, ICH6 latches data on rising and falling edges of this signal from the disk.</p> <p>Disk DMA Ready (Ultra DMA Writes to Disk): When writing to disk, this is de-asserted by the disk to pause burst data transfers.</p>

2.9 LPC Interface

Table 2-9. LPC Interface Signals

Name	Type	Description
LAD[3:0] / FWH[3:0]	I/O	LPC Multiplexed Command, Address, Data: For LAD[3:0], internal pull-ups are provided.
LFRAME# / FWH[4]	O	LPC Frame: LFRAME# indicates the start of an LPC cycle, or an abort.
LDRQ[0]# LDRQ[1]# / GPI[41]	I	<p>LPC Serial DMA/Master Request Inputs: LDRQ[1:0]# are used to request DMA or bus master access. These signals are typically connected to external Super I/O device. An internal pull-up resistor is provided on these signals.</p> <p>LDRQ[1]# may optionally be used as GPI.</p>

2.10 Interrupt Interface

Table 2-10. Interrupt Signals

Name	Type	Description
SERIRQ	I/O	Serial Interrupt Request: This pin implements the serial interrupt protocol.
PIRQ[D:A]#	OD I	PCI Interrupt Requests: In non-APIC mode the PIRQx# signals can be routed to interrupts 3, 4, 5, 6, 7, 9, 10, 11, 12, 14 or 15 as described in the Interrupt Steering section. Each PIRQx# line has a separate Route Control register. In APIC mode, these signals are connected to the internal I/O APIC in the following fashion: PIRQA# is connected to IRQ16, PIRQB# to IRQ17, PIRQC# to IRQ18, and PIRQD# to IRQ19. This frees the legacy interrupts.
PIRQ[H:E]# / GPI[5:2]	OD I	PCI Interrupt Requests: In non-APIC mode the PIRQx# signals can be routed to interrupts 3, 4, 5, 6, 7, 9, 10, 11, 12, 14 or 15 as described in the <i>Interrupt Steering</i> section. Each PIRQx# line has a separate Route Control register. In APIC mode, these signals are connected to the internal I/O APIC in the following fashion: PIRQE# is connected to IRQ20, PIRQF# to IRQ21, PIRQG# to IRQ22, and PIRQH# to IRQ23. This frees the legacy interrupts. If not needed for interrupts, these signals can be used as GPI.
IDEIRQ	I	IDE Interrupt Request: This interrupt input is connected to the IDE drive.

2.11 USB Interface

Table 2-11. USB Interface Signals

Name	Type	Description
USBP[0]P, USBP[0]N, USBP[1]P, USBP[1]N	I/O	Universal Serial Bus Port [1:0] Differential: These differential pairs are used to transmit Data/Address/Command signals for ports 0 and 1. These ports can be routed to UHCI controller #1 or the EHCI controller. NOTE: No external resistors are required on these signals. The ICH6 integrates 15 k Ω pull-downs and provides an output driver impedance of 45 Ω which requires no external series resistor
USBP[2]P, USBP[2]N, USBP[3]P, USBP[3]N	I/O	Universal Serial Bus Port [3:2] Differential: These differential pairs are used to transmit data/address/command signals for ports 2 and 3. These ports can be routed to UHCI controller #2 or the EHCI controller. NOTE: No external resistors are required on these signals. The ICH6 integrates 15 k Ω pull-downs and provides an output driver impedance of 45 Ω which requires no external series resistor
USBP[4]P, USBP[4]N, USBP[5]P, USBP[5]N	I/O	Universal Serial Bus Port [5:4] Differential: These differential pairs are used to transmit Data/Address/Command signals for ports 4 and 5. These ports can be routed to UHCI controller #3 or the EHCI controller. NOTE: No external resistors are required on these signals. The ICH6 integrates 15 k Ω pull-downs and provides an output driver impedance of 45 Ω which requires no external series resistor
USBP[6]P, USBP[6]N, USBP[7]P, USBP[7]N	I/O	Universal Serial Bus Port [7:6] Differential: These differential pairs are used to transmit Data/Address/Command signals for ports 6 and 7. These ports can be routed to UHCI controller #4 or the EHCI controller. NOTE: No external resistors are required on these signals. The ICH6 integrates 15 k Ω pull-downs and provides an output driver impedance of 45 Ω which requires no external series resistor
OC[3:0]# OC[4]# / GPI[9] OC[5]# / GPI[10] OC[6]# / GPI[14] OC[7]# / GPI[15]	I	Overcurrent Indicators: These signals set corresponding bits in the USB controllers to indicate that an overcurrent condition has occurred. OC[7:4]# may optionally be used as GPIs. NOTE: OC[7:0]# are not 5 V tolerant.
USBRBIAS	O	USB Resistor Bias: Analog connection point for an external resistor. This signal is used to set transmit currents and internal load resistors.
USBRBIAS#	I	USB Resistor Bias Complement: Analog connection point for an external resistor. This signal is used to set transmit currents and internal load resistors.

2.12 Power Management Interface

Table 2-12. Power Management Interface Signals (Sheet 1 of 2)

Name	Type	Description
PLTRST#	O	<p>Platform Reset: The ICH6 asserts PLTRST# to reset devices on the platform (e.g., SIO, FWH, LAN, (G)MCH, IDE, TPM, etc.). The ICH6 asserts PLTRST# during power-up and when S/W initiates a hard reset sequence through the Reset Control register (I/O Register CF9h). The ICH6 drives PLTRST# inactive a minimum of 1 ms after both PWROK and VRMPWRGD are driven high. The ICH6 drives PLTRST# active a minimum of 1 ms when initiated through the Reset Control register (I/O Register CF9h).</p> <p>NOTE: PLTRST# is in the VccSus3_3 well.</p>
THRM#	I	<p>Thermal Alarm: Active low signal generated by external hardware to generate an SMI# or SCI.</p>
THRMTRIP#	I	<p>Thermal Trip: When low, this signal indicates that a thermal trip from the processor occurred, and the ICH6 will immediately transition to a S5 state. The ICH6 will not wait for the processor stop grant cycle since the processor has overheated.</p>
SLP_S3#	O	<p>S3 Sleep Control: SLP_S3# is for power plane control. This signal shuts off power to all non-critical systems when in S3 (Suspend To RAM), S4 (Suspend to Disk), or S5 (Soft Off) states.</p>
SLP_S4#	O	<p>S4 Sleep Control: SLP_S4# is for power plane control. This signal shuts power to all non-critical systems when in the S4 (Suspend to Disk) or S5 (Soft Off) state.</p> <p>NOTE: This pin must be used to control the DRAM power to use the ICH6's DRAM power-cycling feature. Refer to Chapter 5.14.11.2 for details.</p>
SLP_S5#	O	<p>S5 Sleep Control: SLP_S5# is for power plane control. This signal is used to shut power off to all non-critical systems when in the S5 (Soft Off) states.</p>
PWROK	I	<p>Power OK: When asserted, PWROK is an indication to the ICH6 that core power has been stable for at least 99 ms and PCICLK has been stable for at least 1 mS. An exception to this rule is if the system is in S3_{HOT}, in which PWROK may or may not stay asserted even though PCICLK may be inactive. PWROK can be driven asynchronously. When PWROK is negated, the ICH6 asserts PLTRST#.</p> <p>NOTE: PWROK must de-assert for a minimum of three RTC clock periods in order for the ICH6 to fully reset the power and properly generate the PLTRST# output</p>
PWRBTN#	I	<p>Power Button: The Power Button will cause SMI# or SCI to indicate a system request to go to a sleep state. If the system is already in a sleep state, this signal will cause a wake event. If PWRBTN# is pressed for more than 4 seconds, this will cause an unconditional transition (power button override) to the S5 state. Override will occur even if the system is in the S1-S4 states. This signal has an internal pull-up resistor and has an internal 16 ms de-bounce on the input.</p>
Ri#	I	<p>Ring Indicate: This signal is an input from a modem. It can be enabled as a wake event, and this is preserved across power failures.</p>
SYS_RESET#	I	<p>System Reset: This pin forces an internal reset after being debounced. The ICH6 will reset immediately if the SMBus is idle; otherwise, it will wait up to 25 ms ± 2 ms for the SMBus to idle before forcing a reset on the system.</p>
RSMRST#	I	<p>Resume Well Reset: This signal is used for resetting the resume power plane logic.</p>

Table 2-12. Power Management Interface Signals (Sheet 2 of 2)

Name	Type	Description
LAN_RST#	I	LAN Reset: When asserted, the internal LAN controller will be put into reset. This signal must be asserted for at least 10 ms after the resume well power (VccSus3_3 and VccSus1_5 in desktop and VccLAN3_3 and VccLAN1_5 in mobile) is valid. When de-asserted, this signal is an indication that the resume (LAN for mobile) well power is stable. NOTE: LAN_RST# must de-assert at some point to complete ICH6 power up sequencing.
WAKE#	I	PCI Express* Wake Event: Sideband wake signal on PCI Express asserted by components requesting wakeup.
MCH_SYNC#	I	MCH SYNC: This input is internally ANDed with the PWROK input. Desktop: Connected to the ICH_SYNC# output of (G)MCH. Mobile: Refer to the Platform Design Guide.
SUS_STAT# / LPCPD#	O	Suspend Status: This signal is asserted by the ICH6 to indicate that the system will be entering a low power state soon. This can be monitored by devices with memory that need to switch from normal refresh to suspend refresh mode. It can also be used by other peripherals as an indication that they should isolate their outputs that may be going to powered-off planes. This signal is called LPCPD# on the LPC I/F.
SUSCLK	O	Suspend Clock: This clock is an output of the RTC generator circuit to be used by other chips for refresh clock.
VRMPWRGD	I	VRM Power Good: This should be connected to be the processor's VRM Power Good signifying the VRM is stable. This signal is internally ANDed with the PWROK input.
BMBUSY# (Mobile Only) / GPI[6] (Desktop Only)	I	Bus Master Busy: To support the C3 state. Indication that a bus master device is busy. When this signal is asserted, the BM_STS bit will be set. If this signal goes active in a C3 state, it is treated as a break event. NOTES: 1. This signal is internally synchronized using the PCICLK and a two-stage synchronizer. It does not need to meet any particular setup or hold time. 2. In desktop configurations, this signal is a GPI.
STP_PCI# (Mobile Only) / GPO[18] (Desktop Only)	O	Stop PCI Clock: This signal is an output to the external clock generator for it to turn off the PCI clock. It is used to support PCI CLKRUN# protocol. If this functionality is not needed, this signal can be configured as a GPO.
STP_CPU# (Mobile Only) / GPO[20] (Desktop Only)	O	Stop Processor Clock: This signal is an output to the external clock generator for it to turn off the processor clock. It is used to support the C3 state. If this functionality is not needed, this signal can be configured as a GPO.
BATLOW# (Mobile Only) / TP[0] (Desktop Only)	I	Battery Low: This signal is an input from battery to indicate that there is insufficient power to boot the system. Assertion will prevent wake from S3–S5 state. This signal can also be enabled to cause an SMI# when asserted.
DPRSLPVR (Mobile Only) / TP[1] (Desktop Only)	O	Deeper Sleep - Voltage Regulator: This signal is used to lower the voltage of VRM during the C4 state. When the signal is high, the voltage regulator outputs the lower "Deeper Sleep" voltage. When low (default), the voltage regulator outputs the higher "Normal" voltage.
DPRSTP# (Mobile Only) / TP[4] (Desktop Only)	O	Deeper Sleep: This is a copy of the DPRSLPVR and it is active low.

2.13 Processor Interface

Table 2-13. Processor Interface Signals (Sheet 1 of 2)

Name	Type	Description
A20M#	O	Mask A20: A20M# will go active based on either setting the appropriate bit in the Port 92h register, or based on the A20GATE input being active.
CPUSLP#	O	Processor Sleep: This signal puts the processor into a state that saves substantial power compared to Stop-Grant state. However, during that time, no snoops occur. The Intel® ICH6 can optionally assert the CPUSLP# signal when going to the S1 state, and will always assert it when going to C3 or C4.
FERR#	I	Numeric Coprocessor Error: This signal is tied to the coprocessor error signal on the processor. FERR# is only used if the ICH6 coprocessor error reporting function is enabled in the OIC.CEN register (Chipset Configuration Registers: Offset 31FFh: bit 1). If FERR# is asserted, the ICH6 generates an internal IRQ13 to its interrupt controller unit. It is also used to gate the IGNNE# signal to ensure that IGNNE# is not asserted to the processor unless FERR# is active. FERR# requires an external weak pull-up to ensure a high level when the coprocessor error function is disabled. NOTE: FERR# can be used in some states for notification by the processor of pending interrupt events. This functionality is independent of the OIC register bit setting.
IGNNE#	O	Ignore Numeric Error: This signal is connected to the ignore error pin on the processor. IGNNE# is only used if the ICH6 coprocessor error reporting function is enabled in the OIC.CEN register (Chipset Configuration Registers: Offset 31FFh: bit 1). If FERR# is active, indicating a coprocessor error, a write to the Coprocessor Error register (I/O register F0h) causes the IGNNE# to be asserted. IGNNE# remains asserted until FERR# is negated. If FERR# is not asserted when the Coprocessor Error register is written, the IGNNE# signal is not asserted.
INIT#	O	Initialization: INIT# is asserted by the ICH6 for 16 PCI clocks to reset the processor. ICH6 can be configured to support processor Built In Self Test (BIST).
INIT3_3V#	O	Initialization 3.3 V: This is the identical 3.3 V copy of INIT# intended for the Firmware Hub.
INTR	O	Processor Interrupt: INTR is asserted by the ICH6 to signal the processor that an interrupt request is pending and needs to be serviced. It is an asynchronous output and normally driven low.
NMI	O	Non-Maskable Interrupt: NMI is used to force a non-Maskable interrupt to the processor. The ICH6 can generate an NMI when either SERR# is asserted or IOCHK# goes active via the SERIRQ# stream. The processor detects an NMI when it detects a rising edge on NMI. NMI is reset by setting the corresponding NMI source enable/disable bit in the NMI Status and Control register (I/O Register 61h).
SMI#	O	System Management Interrupt: SMI# is an active low output synchronous to PCICLK. It is asserted by the ICH6 in response to one of many enabled hardware or software events.
STPCLK#	O	Stop Clock Request: STPCLK# is an active low output synchronous to PCICLK. It is asserted by the ICH6 in response to one of many hardware or software events. When the processor samples STPCLK# asserted, it responds by stopping its internal clock.
RCIN#	I	Keyboard Controller Reset CPU: The keyboard controller can generate INIT# to the processor. This saves the external OR gate with the ICH6's other sources of INIT#. When the ICH6 detects the assertion of this signal, INIT# is generated for 16 PCI clocks. NOTE: The ICH6 will ignore RCIN# assertion during transitions to the S1, S3, S4, and S5 states.

Table 2-13. Processor Interface Signals (Sheet 2 of 2)

Name	Type	Description
A20GATE	I	A20 Gate: A20GATE is from the keyboard controller. The signal acts as an alternative method to force the A20M# signal active. It saves the external OR gate needed with various other chipsets.
CPUPWRGD/ GPO[49]	OD O	Processor Power Good: This signal should be connected to the processor's PWRGOOD input to indicate when the processor power is valid. This is an open-drain output signal (external pull-up resistor required) that represents a logical AND of the ICH6's PWROK and VRMPWRGD signals. This signal may optionally be configured as a GPO.
DPSLP# (Mobile Only) / TP[2] (Desktop Only)	O	Deeper Sleep: DPSLP# is asserted by the ICH6 to the processor. When the signal is low, the processor enters the deep sleep state by gating off the processor Core Clock inside the processor. When the signal is high (default), the processor is not in the deep sleep state.

2.14 SMBus Interface

Table 2-14. SM Bus Interface Signals

Name	Type	Description
SMBDATA	OD I/O	SMBus Data: External pull-up resistor is required.
SMBCLK	OD I/O	SMBus Clock: External pull-up resistor is required.
SMBALERT#/ GPI[11]	I	SMBus Alert: This signal is used to wake the system or generate SMI#. If not used for SMBALERT#, it can be used as a GPI.

2.15 System Management Interface

Table 2-15. System Management Interface Signals

Name	Type	Description
INTRUDER#	I	Intruder Detect: This signal can be set to disable system if box detected open. This signal's status is readable, so it can be used like a GPI if the Intruder Detection is not needed.
SMLINK[1:0]	OD I/O	System Management Link: SMBus link to optional external system management ASIC or LAN controller. External pull-ups are required. Note that SMLINK0 corresponds to an SMBus Clock signal, and SMLINK1 corresponds to an SMBus Data signal.
LINKALERT#	OD I/O	SMLink Alert: Output of the integrated LAN and input to either the integrated ASF or an external management controller in order for the LAN's SMLINK slave to be serviced.

2.16 Real Time Clock Interface

Table 2-16. Real Time Clock Interface

Name	Type	Description
RTCX1	Special	Crystal Input 1: This signal is connected to the 32.768 kHz crystal. If no external crystal is used, then RTCX1 can be driven with the desired clock rate.
RTCX2	Special	Crystal Input 2: This signal is connected to the 32.768 kHz crystal. If no external crystal is used, then RTCX2 should be left floating.

2.17 Other Clocks

Table 2-17. Other Clocks

Name	Type	Description
CLK14	I	Oscillator Clock: Used for 8254 timers. Runs at 14.31818 MHz. This clock is permitted to stop during S3 (or lower) states.
CLK48	I	48 MHz Clock: Used to run the USB controller. Runs at 48.000 MHz. This clock is permitted to stop during S3 (or lower) states.
SATA_CLKP SATA_CLKN	I	100 MHz Differential Clock: These signals are used to run the SATA controller. Runs at 100 MHz. This clock is permitted to stop during S3 (or lower) states in desktop configurations or S1 (or lower) states.
DMI_CLKP, DMI_CLKN	I	100 MHz Differential Clock: These signals are used to run the Direct Media Interface. Runs at 100 MHz.

2.18 Miscellaneous Signals

Table 2-18. Miscellaneous Signals (Sheet 1 of 2)

Name	Type	Description
INTVRMEN	I	Internal Voltage Regulator Enable: This signal enables the internal 1.5 V Suspend regulator when connected to VccRTC. When connected to Vss, the internal regulator is disabled
SPKR	O	Speaker: The SPKR signal is the output of counter 2 and is internally “ANDed” with Port 61h bit 1 to provide Speaker Data Enable. This signal drives an external speaker driver device, which in turn drives the system speaker. Upon PLTRST#, its output state is 0. NOTE: SPKR is sampled at the rising edge of PWROK as a functional strap. See Section 2.22.1 for more details. There is a weak integrated pull-down resistor on SPKR pin.
RTCST#	I	RTC Reset: When asserted, this signal resets register bits in the RTC well. NOTES: 1. Unless CMOS is being cleared (only to be done in the G3 power state), the RTCST# input must always be high when all other RTC power planes are on. 2. In the case where the RTC battery is dead or missing on the platform, the RTCST# pin must rise before the RSMRST# pin.

Table 2-18. Miscellaneous Signals (Sheet 2 of 2)

Name	Type	Description
TP[0] (Desktop Only) / BATLOW# (Mobile Only)	I	Test Point 0: This signal must have an external pull-up to VccSus3_3.
TP[1] (Desktop Only) / DPRSLPVR# (Mobile Only)	O	Test Point 1: Route signal to a test point.
TP[2] (Desktop Only) / DPSLP# (Mobile Only)	O	Test Point 2: Route signal to a test point.
TP[3]	I	Test Point 3: Route signal to a test point.
TP[4] (Desktop Only) / DPRSTP# (Mobile Only)	O	Test Point 4: Route signal to a test point.

2.19 AC '97/Intel® High Definition Audio Link

Table 2-19. AC '97/Intel® High Definition Audio Link Signals

Name	Type	Description
ACZ_RST#	O	AC '97/Intel High Definition Audio Reset: This signal is a master hardware reset to external codec(s).
ACZ_SYNC	O	AC '97/Intel High Definition Audio Sync: This signal is a 48 kHz fixed rate sample sync to the codec(s). Also used to encode the stream number.
ACZ_BIT_CLK	I/O	AC '97 Bit Clock Input: This signal is a 12.288 MHz serial data clock generated by the external codec(s). This signal has an integrated pull-down resistor (see Note below). Intel High Definition Audio Bit Clock Output: This signal is a 24.000 MHz serial data clock generated by the Intel High Definition Audio controller (the Intel® ICH6). This signal has an integrated pull-down resistor so that ACZ_BIT_CLK does not float when an Intel High Definition Audio codec (or no codec) is connected but the signals are temporarily configured as AC '97.
ACZ_SDOUT	O	AC '97/Intel High Definition Audio Serial Data Out: This signal is a serial TDM data output to the codec(s). This serial output is double-pumped for a bit rate of 48 Mb/s for Intel High Definition Audio. NOTE: ACZ_SDOUT is sampled at the rising edge of PWROK as a functional strap. See Section 2.22.1 for more details. There is a weak integrated pull-down resistor on the ACZ_SDOUT pin.
ACZ_SDIN[2:0]	I	AC '97/Intel High Definition Audio Serial Data In [2:0]: This signal is a serial TDM data inputs from the three codecs. The serial input is single-pumped for a bit rate of 24 Mb/s for Intel High Definition Audio. These signals have integrated pull-down resistors, which are always enabled.

NOTES:

- Some signals have integrated pull-ups or pull-downs. Consult table in Section 3.1 for details.
- Intel High Definition Audio mode is selected through D30:F1:40h, bit 0: AZ/AC97#. This bit selects the mode of the shared Intel High Definition Audio/AC '97 signals. When set to 0 AC '97 mode is selected. When set to 1 Intel High Definition Audio mode is selected. The bit defaults to 0 (AC '97 mode).

2.20 General Purpose I/O

Table 2-20. General Purpose I/O Signals^{1,2} (Sheet 1 of 2)

Name	Type	Tolerance	Power Well	Description
GPO[49]	OD O	V_CPU_IO	Core	This signal is fixed as output only and can instead be used as CPUPWRGD.
GPO[48]	O	3.3 V	Core	This signal is fixed as output only and can instead be used as GNT4#.
GPIO[47:42]	N/A	N/A	N/A	This signal is not implemented.
GPI[41]	I	3.3 V	Core	This signal is fixed as input only and can be used instead as LDRQ1#.
GPI[40]	I	5 V	Core	This signal is fixed as input only and can be used instead as REQ4#.
GPIO[39:35]	N/A	N/A	N/A	This signal is not implemented.
GPIO[34:33]	I/O	3.3 V	Core	This signal can be input or output and is unmultiplexed
GPIO[32] (Desktop Only)	I/O	3.3 V	Core	This signal can be input or output. In mobile, this GPIO is not implemented and is used instead as CLKRUN#.
GPI[31]	I	3.3 V	Core	This signal is fixed as input only and can instead be used for SATA[3]GP. This signal is used only as GPI[31] in mobile.
GPI[30]	I	3.3 V	Core	This signal is fixed as input only and can instead be used for SATA[2]GP.
GPI[29]	I	3.3 V	Core	This signal is fixed as input only and can instead be used for SATA[1]GP. It is used only as GPI[29] in mobile.
GPIO[28:27]	I/O	3.3 V	Resume	This signal can be input or output and is unmultiplexed.
GPI[26]	I	3.3 V	Core	This signal is fixed as input only and can instead be used for SATA[0]GP.
GPIO[25]	I/O	3.3 V	Resume	This signal can be input or output and is unmultiplexed. It is a strap for internal Vcc2_5 regulator. See Section 2.22.1 .
GPIO[24]	I/O	3.3 V	Resume	This signal can be input or output and is unmultiplexed.
GPO[23]	O	3.3 V	Core	This signal is fixed as output only.
GPIO[22]	N/A	N/A	N/A	This signal is not Implemented
GPO[21]	O	3.3 V	Core	This signal is fixed as output only and is unmultiplexed
GPO[20] (Desktop Only)	O	3.3 V	Core	This signal is fixed as output only. In mobile, this GPO is not implemented and is used instead as STP_CPU#.
GPO[19]	O	3.3 V	Core	This signal is fixed as output only. NOTE: GPO[19] may be programmed to blink (controllable by GPO_BLINK (D31:F0:Offset GPIOBASE+18h:bit 19)).

Table 2-20. General Purpose I/O Signals^{1,2} (Sheet 2 of 2)

Name	Type	Tolerance	Power Well	Description
GPO[18] (Desktop Only)	O	3.3 V	Core	This signal is fixed as output only. In mobile configurations this GPO is not implemented and is used instead as STP_PCI#. NOTE: GPO[18] will blink by default immediately after reset (controllable by GPO_BLINK (D31:F0:Offset GPIOBASE+18h:bit 18)).
GPO[17]	O	3.3 V	Core	This signal is fixed as output only and can be used instead as PCI GNT[5]#.
GPO[16]	O	3.3 V	Core	This signal is fixed as output only and can be used instead as PCI GNT[6]#.
GPI[15:14]³	I	3.3 V	Resume	This signal is fixed as input only and can be used instead as OC[7:6]#
GPI[13]³	I	3.3 V	Resume	This signal is fixed as input only and is unmultiplexed.
GPI[12]³	I	3.3 V	Core	This signal is fixed as input only and is unmultiplexed.
GPI[11]³	I	3.3 V	Resume	This signal is fixed as input only and can be used instead as SMBALERT#.
GPI[10:9]³	I	3.3 V	Resume	This signal is fixed as input only and can be used instead as OC[5:4]#.
GPI[8]³	I	3.3 V	Resume	This signal is fixed as input only and is unmultiplexed.
GPI[7]³	I	3.3 V	Core	This signal is fixed as input only and is unmultiplexed.
GPI[6]³ (Desktop Only)	I	3.3 V	Core	This signal is fixed as input only. In mobile this GPI is not implemented and is used instead as BMBUSY#.
GPI[5:2]³	I	5 V	Core	This signal is fixed as input only and can be used instead as PIRQ[H:E]#.
GPI[1:0]³	I	5 V	Core	This signal is fixed as input only and can be used instead as PCI REQ[6:5]#.

NOTES:

- All inputs are sticky. The status bit remains set as long as the input was asserted for two clocks. GPIs are sampled on PCI clocks in S0/S1 for desktop and S0 for mobile configurations. GPIs are sampled on RTC clocks in S3/S4/S5 for desktop and S1/S3/S4/S5 in mobile configurations.
- Some GPIOs exist in the VccSus3_3 power plane. Care must be taken to make sure GPIO signals are not driven high into powered-down planes. Some ICH6 GPIOs may be connected to pins on devices that exist in the core well. If these GPIOs are outputs, there is a danger that a loss of core power (PWROK low) or a Power Button Override event will result in the Intel ICH6 driving a pin to a logic 1 to another device that is powered down.
- GPI[15:0] can be configured to cause a SMI# or SCI. Note that a GPI can be routed to either an SMI# or an SCI, but not both.

2.21 Power and Ground

Table 2-21. Power and Ground Signals (Sheet 1 of 2)

Name	Description
Vcc3_3	3.3 V supply for core well I/O buffers (22 pins). This power may be shut off in S3, S4, S5 or G3 states.
Vcc1_5_A	1.5 V supply for core well logic, group A (52 pins). This power may be shut off in S3, S4, S5 or G3 states.
Vcc1_5_B	1.5 V supply for core well logic, group B (45 pins). This power may be shut off in S3, S4, S5 or G3 states.
Vcc2_5	2.5 V supply for internal logic (2 pins). This power may be shut off in S3, S4, S5 or G3 states. NOTE: This voltage may be generated internally (see Section 2.22.1 for strapping option). If generated internally, these pins should not be connected to an external supply.
V5REF	Reference for 5 V tolerance on core well inputs (2 pins). This power may be shut off in S3, S4, S5 or G3 states.
VccSus3_3	3.3 V supply for resume well I/O buffers (20 pins). This power is not expected to be shut off unless the system is unplugged in desktop configurations or the main battery is removed or completely drained and AC power is not available in mobile configurations.
VccSus1_5	1.5 V supply for resume well logic (3 pin). This power is not expected to be shut off unless the system is unplugged in desktop configurations or the main battery is removed or completely drained and AC power is not available in mobile configurations. This voltage may be generated internally (see Section 2.22.1 for strapping option). If generated internally, these pins should not be connected to an external supply.
V5REF_Sus	Reference for 5 V tolerance on resume well inputs (1 pin). This power is not expected to be shut off unless the system is unplugged in desktop configurations or the main battery is removed or completely drained and AC power is not available in mobile configurations.
VccLAN3_3 (Mobile Only)	3.3 V supply for LAN Connect interface buffers (4 pins). This is a separate power plane that may or may not be powered in S3–S5 states depending upon the presence or absence of AC power and network connectivity. This plane must be on in S0 and S1. NOTE: In Desktop mode these signals are added to the VccSus3_3 group.
VccLAN1_5 (Mobile Only)	1.5 V supply for LAN controller logic (2 pins). This is a separate power plane that may or may not be powered in S3–S5 states depending upon the presence or absence of AC power and network connectivity. This plane must be on in S0 and S1. NOTES: 1. This voltage will be generated internally if VccSus1_5 is generated internally (see Section 2.22.1 for strapping option). If generated internally, these pins should not be connected to an external supply. 2. In Desktop mode these signals are added to the VccSus1_5 group.
VccRTC	3.3 V (can drop to 2.0 V min. in G3 state) supply for the RTC well (1 pin). This power is not expected to be shut off unless the RTC battery is removed or completely drained. NOTE: Implementations should not attempt to clear CMOS by using a jumper to pull VccRTC low. Clearing CMOS in an ICH6-based platform can be done by using a jumper on RTCRST# or GPI.
VccUSBPLL	1.5 V supply for core well logic (1 pin). This signal is used for the USB PLL. This power may be shut off in S3, S4, S5 or G3 states. Must be powered even if USB not used.
VccDMIPLL	1.5 V supply for core well logic (1 pins). This signal is used for the DMI PLL. This power may be shut off in S3, S4, S5 or G3 states.

Table 2-21. Power and Ground Signals (Sheet 2 of 2)

Name	Description
VccSATAPLL	1.5 V supply for core well logic (1 pins). This signal is used for the SATA PLL. This power may be shut off in S3, S4, S5 or G3 states. Must be powered even if SATA not used.
V_CPU_IO	Powered by the same supply as the processor I/O voltage (3 pins). This supply is used to drive the processor interface signals listed in Table 2-13.
Vss	Grounds (172 pins).

2.22 Pin Straps

2.22.1 Functional Straps

The following signals are used for static configuration. They are sampled at the rising edge of PWROK to select configurations (except as noted), and then revert later to their normal usage. To invoke the associated mode, the signal should be driven at least four PCI clocks prior to the time it is sampled.

Table 2-22. Functional Strap Definitions (Sheet 1 of 2)

Signal	Usage	When Sampled	Comment
GNT[6]#/GPO[16]	Top-Block Swap Override	Rising Edge of PWROK	The signal has a weak internal pull-up. If the signal is sampled low, this indicates that the system is strapped to the "top-block swap" mode (ICH6 inverts A16 for all cycles targeting FWH BIOS space). The status of this strap is readable via the Top Swap bit (Chipset Configuration Registers:Offset 3414h:bit 0). Note that software will not be able to clear the Top-Swap bit until the system is rebooted without GNT6# being pulled down.
LINKALERT#	Reserved		This signal requires an external pull-up resistor.
SPKR	No Reboot	Rising Edge of PWROK	The signal has a weak internal pull-down. If the signal is sampled high, this indicates that the system is strapped to the "No Reboot" mode (ICH6 will disable the TCO Timer system reboot feature). The status of this strap is readable via the NO REBOOT bit (Chipset Configuration Registers:Offset 3410h:bit 5).
INTVRMEN	Integrated VccSus1_5 VRM Enable/Disable	Always	This signal enables integrated VccSus1_5 VRM when sampled high.
GPIO[25]	Integrated Vcc2_5 VRM Enable/Disable	Rising Edge of RSMRST#	This signal enables integrated Vcc2_5 VRM when sampled low. This signal has a weak internal pull-up during RSMRST# and is disabled within 100 ms after RSMRST# de-asserts.
EE_CS	Reserved		This signal has a weak internal pull-down. NOTE: This signal should not be pulled high.

Table 2-22. Functional Strap Definitions (Sheet 2 of 2)

Signal	Usage	When Sampled	Comment
GNT[5]#/GPO[17]	Boot BIOS Destination Selection	Rising Edge of PWROK	Signal has a weak internal pull-up. Allows for select memory ranges to be forwarded out the PCI Interface as opposed to the Firmware Hub. When sampled high, destination is LPC. Also controllable via Boot BIOS Destination bit (Chipset Configuration Registers:Offset 3410h:bit 3). NOTE: This functionality intended for debug/testing only.
EE_DOUT	Reserved		This signal has a weak internal pull-up. NOTE: This signal should not be pulled low.
ACZ_SDOOUT	XOR Chain Entrance / PCI Express* Port Configuration bit 1	Rising Edge of PWROK	Allows entrance to XOR Chain testing when TP[3] pulled low at rising edge of PWROK. See Chapter 24 for XOR Chain functionality information. When TP[3] not pulled low at rising edge of PWROK, sets bit 1 of RPC.PC (Chipset Configuration Registers:Offset 224h). See Section 7.1.30 for details. This signal has a weak internal pull-down.
ACZ_SYNC	PCI Express Port Configuration bit 0	Rising Edge of PWROK	This signal has a weak internal pull-down. Sets bit 0 of RPC.PC (Chipset Configuration Registers:Offset 224h). See Section 7.1.30 for details.
TP[1] (Desktop Only) / DPRSLPVR (Mobile Only)	Reserved		This signal has a weak internal pull-down. NOTE: This signal should not be pulled high.
SATALED#	Reserved		This signal has a weak internal pull-up enabled only when PLTRST# is asserted. NOTE: This signal should not be pulled low.
REQ[4:1]#	XOR Chain Selection	Rising Edge of PWROK	See Chapter 24 for functionality information.
TP[3]	XOR Chain Entrance	Rising Edge of PWROK	See Chapter 24 for functionality information. This signal has a weak internal pull-up. NOTE: This signal should not be pulled low unless using XOR Chain testing.

NOTE: See Section 3.1 for full details on pull-up/pull-down resistors.

2.22.2 External RTC Circuitry

To reduce RTC well power consumption, the ICH6 implements an internal oscillator circuit that is sensitive to step voltage changes in VccRTC. Figure 2-3 shows an example schematic recommended to ensure correct operation of the ICH6 RTC.

Figure 2-3. Example External RTC Circuit

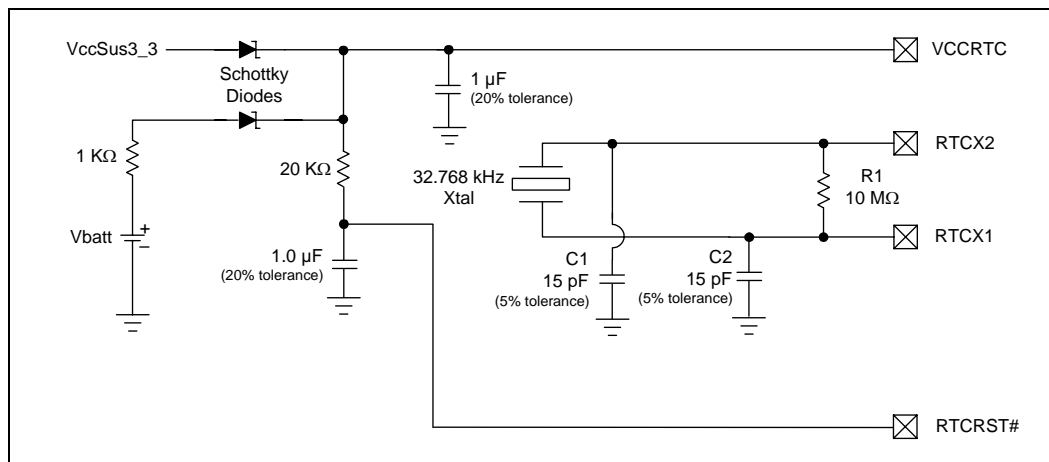

NOTE: C1 and C2 depend on crystal load.

2.22.3 Power Sequencing Requirements

2.22.3.1 V5REF / Vcc3_3 Sequencing Requirements

V5REF is the reference voltage for 5 V tolerance on inputs to the ICH6. V5REF must be powered up before Vcc3_3, or after Vcc3_3 within 0.7 V. Also, V5REF must power down after Vcc3_3, or before Vcc3_3 within 0.7 V. The rule must be followed in order to ensure the safety of the ICH6. If the rule is violated, internal diodes will attempt to draw power sufficient to damage the diodes from the Vcc3_3 rail.

This rule also applies to V5REF_Sus and VccSus3_3. However, in most platforms, the VccSus3_3 rail is derived from the 5 VSB on the power supply through a voltage regulator and therefore, the VccSus3_3 rail will always come up after the VccSus5 rail. As a result, V5REF_Sus (which is derived directly from VccSus5) will always be powered up before VccSus3_3 and thus circuitry to satisfy the sequence requirement is not needed. However, in platforms that do not derive the VccSus3_3 rail from the VccSus5 rail, this rule must be observed in the platform design as described above.

2.22.3.2 3.3 V/1.5 V Standby Power Sequencing Requirements

For platforms that use the integrated 1.5 V standby regulator, there are **no** power sequencing requirements for associated 3.3 V/1.5 V (standby or core) rails of the ICH6.

For platforms that use an external 1.5 V standby regulator to power VccSus1_5 of the ICH6 (the internal voltage regulator is disabled), the platform must ensure that VccSus3_3 ramps up before VccSus1_5 or after VccSus1_5 within 0.7 V. VccSus1_5 must power down before VccSus3_3 or after VccSus3_3 within 0.7 V.

VccLAN3_3 (mobile only) must power up before VccLAN1_5 (mobile only) or after VccLAN1_5 within 0.7 V. VccLAN1_5 must power down before VccLAN3_3 or after VccLAN3_3 within 0.7 V.

2.22.3.3 3.3 V/2.5 V Power Sequencing Requirements

For platforms that use the integrated 2.5 V regulator, there are no power sequencing requirements for associated 3.3 V/2.5 V rails of the ICH6.

For platforms that use an external 2.5 V regulator to power Vcc2_5 of the ICH6 (the internal voltage regulator is disabled), the platform must ensure that Vcc3_3 must power up before Vcc2_5 or after Vcc2_5 within 0.7 V.

2.22.3.4 Vcc1_5/V_CPU_IO Power Sequencing Requirements

Vcc1_5 must power up before V_CPU_IO or after V_CPU_IO within 0.3 V. V_CPU_IO must power down before Vcc1_5 or after Vcc1_5 within 0.7 V.

Note: Loaded from EEPROM. If EEPROM contains either 0000h or FFFFh in the device ID location, then 266Ch is used. Refer to the ICH6 EEPROM Map and Programming Guide for LAN Device IDs.

§

3 Pin States

3.1 Integrated Pull-Ups and Pull-Downs

Table 3-1. Integrated Pull-Up and Pull-Down Resistors

Signal	Resistor Type	Nominal Value	Notes
ACZ_BIT_CLK, AC '97	Pull-down	20K	1, 2, 3
ACZ_RST#, AC '97	Pull-down	20K	1, 2, 4
ACZ_SDIN[2:0], AC '97	Pull-down	20K	2, 4
ACZ_SDOUT, AC '97	Pull-down	20K	2, 4, 5
ACZ_SYNC, AC '97	Pull-down	20K	2, 4, 5
ACZ_BIT_CLK, Intel High Definition Audio	Pull-Down	20K	2, 6, 7
ACZ_RST#, Intel High Definition Audio	None	N/A	2
ACZ_SDIN[2:0], Intel High Definition Audio	Pull-down	20K	2, 4
ACZ_SDOUT, Intel High Definition Audio	Pull-down	20K	1, 2
ACZ_SYNC, Intel High Definition Audio	Pull-down	20K	2, 4
DD[7]	Pull-down	11.5K	8
DDREQ	Pull-down	11.5K	8
DPRSLPVR / TP[1]	Pull-down	20K	4, 9
EE_CS	Pull-down	20K	10, 11
EE_DIN	Pull-up	20K	10
EE_DOUT	Pull-up	20K	10
GNT[3:0]	Pull-up	20K	10, 12
GNT[4]# / GPO[48]	Pull-up	20K	10, 12
GNT[5]# / GPO[17]	Pull-up	20K	10
GNT[6]# / GPO[16]	Pull-up	20K	10
GPIO[25]	Pull-up	20K	10, 11
LAD[3:0]# / FHW[3:0]#	Pull-up	20K	10
LAN_RXD[2:0]	Pull-up	20K	13
LAN_CLK	Pull-down	100K	14
LDRQ[0]	Pull-up	20K	10
LDRQ[1] / GPI[41]	Pull-up	20K	10
PME#	Pull-up	20K	10
PWRBTN#	Pull-up	20K	10
SATALED#	Pull-up	15K	15
SPKR	Pull-down	20K	4
TP[3]	Pull-up	20K	16
USB[7:0] [P,N]	Pull-down	15K	17

NOTES:

- The pull-down resistors on ACZ_BIT_CLK (AC '97) and ACZ_RST# are enabled when either:
 - The LSO bit (bit 3) in the AC '97 Global Control Register (D30:F2:2C) is set to 1, or
 - Both Function 2 and Function 3 of Device 30 are disabled.
 Otherwise, the integrated Pull-down resistor is disabled.
- The AC '97/Intel High Definition Audio Link signals may either all be configured to be an AC-Link or an Intel High Definition Audio Link.

3. Simulation data shows that these resistor values can range from 10 k Ω to 20 k Ω .
4. Simulation data shows that these resistor values can range from 9 k Ω to 50 k Ω .
5. The pull-down resistors on ACZ_SYNC (AC '97) and ACZ_SDOUT (AC '97) are enabled during reset and also enabled when either:
 - The LSO bit (bit 3) in the AC '97 Global Control Register (D30:F2:2C) is set to 1, or
 - Both Function 2 and Function 3 of Device 30 are disabled.
 Otherwise, the integrated Pull-down resistor is disabled.
6. Simulation data shows that these resistor values can range from 10 k Ω to 40 k Ω .
7. The pull-down on this signal (in Intel High Definition Audio mode) is only enabled when in S3_{COLD}.
8. Simulation data shows that these resistor values can range from 5.7 k Ω to 28.3 k Ω .
9. The pull-up or pull-down on this signal is only enabled at boot/reset for strapping function.
10. Simulation data shows that these resistor values can range from 15 k Ω to 35 k Ω .
11. The pull-down on this signal is only enabled when LAN_RST# is asserted.
12. The internal pull-up is enabled only when the PCIRST# pin is driven low and the PWROK indication is high.
13. Simulation data shows that these resistor values can range from 15 k Ω to 30 k Ω .
14. Simulation data shows that these resistor values can range from 45 k Ω to 170 k Ω .
15. Simulation data shows that these resistor values can range from 10 k Ω to 20 k Ω . The internal pull-up is only enabled only during PLTRST# assertion.
16. Simulation data shows that these resistor values can range from 10 k Ω to 30 k Ω .
17. Simulation data shows that these resistor values can range from 14.25 k Ω to 24.8 k Ω .

3.2 IDE Integrated Series Termination Resistors

Table 3-2 shows the ICH6 IDE signals that have integrated series termination resistors.

Table 3-2. IDE Series Termination Resistors

Signal	Integrated Series Termination Resistor Value
DD[15:0], DIOW#, DIOR#, DREQ, DDACK#, IORDY, DA[2:0], DCS1#, DCS3#, IDEIRQ	approximately 33 Ω (See Note)

NOTE: Simulation data indicates that the integrated series termination resistors are a nominal 33 Ω but can range from 21 Ω to 75 Ω .

3.3 Output and I/O Signals Planes and States

Table 3-3 and Table 3-4 shows the power plane associated with the output and I/O signals, as well as the state at various times. Within the table, the following terms are used:

“High-Z”	Tri-state. ICH6 not driving the signal high or low.
“High”	ICH6 is driving the signal to a logic 1
“Low”	ICH6 is driving the signal to a logic 0
“Defined”	Driven to a level that is defined by the function (will be high or low)
“Undefined”	ICH6 is driving the signal, but the value is indeterminate.
“Running”	Clock is toggling or signal is transitioning because function not stopping
“Off”	The power plane is off, so ICH6 is not driving

Note that the signal levels are the same in S4 and S5, except as noted.

**Table 3-3. Power Plane and States for Output and I/O Signals for Desktop Configurations
(Sheet 1 of 4)**

Signal Name	Power Plane	During PLTRST# ¹ / RSMRST# ²	Immediately after PLTRST# ¹ / RSMRST# ²	S1	S3 _{COLD} ³	S4/S5
PCI Express*						
PETp[1], PETn[1] PETp[2], PETn[2] PETp[3], PETn[3] PETp[4], PETn[4]	Vcc3_3	High	High ⁴	Defined	Off	Off
PCI Bus						
AD[31:0]	Vcc3_3	Low	Undefined	Defined	Off	Off
C/BE[3:0]#	Vcc3_3	Low	Undefined	Defined	Off	Off
DEVSEL#	Vcc3_3	High-Z	High-Z	High-Z	Off	Off
FRAME#	Vcc3_3	High-Z	High-Z	High-Z	Off	Off
GNT[4:0]#	Vcc3_3	High with Internal Pull-ups	High	High	Off	Off
GNT[5]#	Vcc3_3	High-Z with Internal Pull-up	High	High	Off	Off
GNT[6]#	Vcc3_3	High-Z with Internal Pull-up	High	High	Off	Off
IRDY#, TRDY#	Vcc3_3	High-Z	High-Z	High-Z	Off	Off
PAR	Vcc3_3	Low	Undefined	Defined	Off	Off
PCIRST#	VccSus3_3	Low	High	High	Low	Low
PERR#	Vcc3_3	High-Z	High-Z	High-Z	Off	Off
PLOCK#	Vcc3_3	High-Z	High-Z	High-Z	Off	Off
STOP#	Vcc3_3	High-Z	High-Z	High-Z	Off	Off
LPC Interface						
LAD[3:0] / FWH[3:0]	Vcc3_3	High	High	High	Off	Off
LFRAME# / FWH[4]	Vcc3_3	High	High	High	Off	Off
LAN Connect and EEPROM Interface						
EE_CS	VccSus3_3	Low	Running	Defined	Defined	Defined
EE_DOUT	VccSus3_3	High	High	Defined	Defined	Defined
EE_SHCLK	VccSus3_3	High-Z	Running	Defined	Defined	Defined
LAN_RSTSYNC	VccSus3_3	High	Low	Defined	Defined	Defined
LAN_TXD[2:0]	VccSus3_3	Low	Low	Defined	Defined	Defined

**Table 3-3. Power Plane and States for Output and I/O Signals for Desktop Configurations
(Sheet 2 of 4)**

Signal Name	Power Plane	During PLTRST# ¹ / RSMRST# ²	Immediately after PLTRST# ¹ / RSMRST# ²	S1	S3 _{COLD} ³	S4/S5
IDE Interface						
DA[2:0]	Vcc3_3	Undefined	Undefined	Undefined	Off	Off
DCS1#, DCS3#	Vcc3_3	High	High	High	Off	Off
DD[15:8], DD[6:0]	Vcc3_3	High-Z	High-Z	High-Z	Off	Off
DD[7]	Vcc3_3	Low	Low	Low	Off	Off
DDACK#	Vcc3_3	High	High	High	Off	Off
DIOR#, DIOW#	Vcc3_3	High	High	High	Off	Off
SATA Interface						
SATA[0]TXP, SATA[0]TXN SATA[1]TXP, SATA[1]TXN SATA[2]TXP, SATA[2]TXN SATA[3]TXP, SATA[3]TXN	Vcc3_3	High-Z	High-Z	Defined	Off	Off
SATALED#	Vcc3_3	High-Z	High-Z	Defined	Off	Off
SATARBIAS	Vcc3_3	High-Z	High-Z	High-Z	Off	Off
Interrupts						
PIRQ[A:H]#	Vcc3_3	High-Z	High-Z	High-Z	Off	Off
SERIRQ	Vcc3_3	High-Z	High-Z	High-Z	Off	Off
USB Interface						
USBP[7:0][P,N]	VccSus3_3	Low	Low	Low	Low	Low
USBRBIAS	VccSus3_3	High-Z	High-Z	Defined	Defined	Defined
Power Management						
PLTRST#	VccSus3_3	Low	High	High	Low	Low
SLP_S3#	VccSus3_3	Low	High	High	Low	Low
SLP_S4#	VccSus3_3	Low	High	High	High	Low
SLP_S5#	VccSus3_3	Low	High	High	High	Low ⁵
SUS_STAT#	VccSus3_3	Low	High	High	Low	Low
SUSCLK	VccSus3_3	Low	Running			

Table 3-3. Power Plane and States for Output and I/O Signals for Desktop Configurations (Sheet 3 of 4)

Signal Name	Power Plane	During PLTRST# ¹ / RSMRST# ²	Immediately after PLTRST# ¹ / RSMRST# ²	S1	S3 _{COLD} ³	S4/S5
Processor Interface						
A20M#	V_CPU_IO	Note 6	Note 6	High	Off	Off
CPUPWRGD	V_CPU_IO	Note 7	High-Z	High-Z	Off	Off
CPUSLP#	V_CPU_IO	High	High	Defined	Off	Off
IGNNE#	V_CPU_IO	Note 6	Note 6	High	Off	Off
INIT#	V_CPU_IO	High	High	High	Off	Off
INIT3_3V#	Vcc3_3	High	High	High	Off	Off
INTR	V_CPU_IO	Note 8	Note 8	Low	Off	Off
NMI	V_CPU_IO	Note 8	Note 8	Low	Off	Off
SMI#	V_CPU_IO	High	High	High	Off	Off
STPCLK#	V_CPU_IO	High	High	Low	Off	Off
SMBus Interface						
SMBCLK, SMBDATA	VccSus3_3	High-Z	High-Z	Defined	Defined	Defined
System Management Interface						
SMLINK[1:0]	VccSus3_3	High-Z	High-Z	Defined	Defined	Defined
LINKALERT#	VccSus3_3	High-Z	High-Z	Defined	Defined	Defined
Miscellaneous Signals						
SPKR	Vcc3_3	High-Z with Internal Pull-down	Low	Defined	Off	Off
AC '97 Interface						
ACZ_RST#	VccSus3_3	Low	Low	Cold Reset Bit (High)	Low	Low
ACZ_SDOUT	Vcc3_3	Low	Running	Low	Off	Off
ACZ_SYNC	Vcc3_3	Low	Running	Low	Off	Off
Intel High Definition Audio Interface						
ACZ_RST#	VccSus3_3	Low	Low ⁹	Low	Low	Low
ACZ_SDOUT	Vcc3_3	High-Z with Internal Pull-down	Running	Low	Off	Off
ACZ_SYNC	Vcc3_3	High-Z with Internal Pull-down	Running	Low	Off	Off
ACZ_BIT_CLK	Vcc3_3	High-Z with Internal Pull-down	Low ⁹	Low	Off	Off

**Table 3-3. Power Plane and States for Output and I/O Signals for Desktop Configurations
(Sheet 4 of 4)**

Signal Name	Power Plane	During PLTRST# ¹ / RSMRST# ²	Immediately after PLTRST# ¹ / RSMRST# ²	S1	S3 _{COLD} ³	S4/S5
Unmultiplexed GPIO Signals						
GPO[18]	Vcc3_3	High	Note 10	Defined	Off	Off
GPO[21:19]	Vcc3_3	High	High	Defined	Off	Off
GPO[23]	Vcc3_3	Low	Low	Defined	Off	Off
GPIO[24]	VccSus3_3	High	High ¹¹	Defined	Defined	Defined
GPIO[25]	VccSus3_3	High	High	Defined	Defined	Defined
GPIO[28:27]	VccSus3_3	High	High	Defined	Defined	Defined
GPIO[34:32]	Vcc3_3	High	High	Defined	Off	Off

NOTES:

1. The states of Vcc3_3 signals are taken at the times During PLTRST# and Immediately after PLTRST#.
2. The states of VccSus3_3 signals are taken at the times During RSMRST# and Immediately after RSMRST#.
3. In S3_{HOT}, signal states are platform implementation specific, as some external components and interfaces may be powered when the ICH6 is in the S3_{HOT} state.
4. PETp/n[4:1] high until port is enabled by software.
5. SLP_S5# signals will be high in the S4 state.
6. ICH6 drives these signals Low before PWROK rising and High after the processor reset
7. CPUPWRGD is an open-drain output that represents a logical AND of the ICH6's VRMPWRGD and PWROK signals, and thus will be driven low by ICH6 when either VRMPWRGD or PWROK are inactive. During boot, or during a hard reset with power cycling, CPUPWRGD will be expected to transition from low to High-Z.
8. ICH6 drives these signals Low before PWROK rising and Low after the processor reset.
9. Low until Intel High Definition Audio Controller Reset bit set (D27:F0:Offset HDBAR+08h:bit 0), at which time ACZ_RST# will be High and ACZ_BIT_CLK will be Running.
10. GPO[18] will toggle at a frequency of approximately 1 Hz when the ICH6 comes out of reset
11. GPIO[25] transitions from pulled high internally to actively driven following the de-assertion of the RSMRST# pin.

**Table 3-4. Power Plane and States for Output and I/O Signals for Mobile Configurations
(Sheet 1 of 4)**

Signal Name	Power Plane	During PLTRST# ⁶ / RSMRST# ⁷	Immediately after PLTRST# ⁶ / RSMRST# ⁷	C3/C4	S1	S3 _{COLD} ¹³	S4/S5
PCI Express*							
PETp[1], PETn[1] PETp[2], PETn[2] PETp[3], PETn[3] PETp[4], PETn[4]	Vcc3_3	High	High ¹²	Defined	Defined	Off	Off
PCI Bus							
AD[31:0]	Vcc3_3	Low	Undefined	Defined	Defined	Off	Off
C/BE[3:0]#	Vcc3_3	Low	Undefined	Defined	Defined	Off	Off
CLKRUN#	Vcc3_3	Low	Low	Defined		Off	Off
DEVSEL#	Vcc3_3	High-Z	High-Z	High-Z	High-Z	Off	Off
FRAME#	Vcc3_3	High-Z	High-Z	High-Z	High-Z	Off	Off
GNT[4:0]#	Vcc3_3	High with Internal Pull-ups	High	High	High	Off	Off
GNT[5]#	Vcc3_3	High-Z with internal Pull-up	High	High	High	Off	Off
GNT[6]#	Vcc3_3	High-Z with internal Pull-up	High	High	High	Off	Off
IRDY#, TRDY#	Vcc3_3	High-Z	High-Z	High-Z	High-Z	Off	Off
PAR	Vcc3_3	Low	Undefined	Defined	Defined	Off	Off
PCIRST#	VccSus3_3	Low	High	High	High	Low	Low
PERR#	Vcc3_3	High-Z	High-Z	High-Z	High-Z	Off	Off
PLOCK#	Vcc3_3	High-Z	High-Z	High-Z	High-Z	Off	Off
STOP#	Vcc3_3	High-Z	High-Z	High-Z	High-Z	Off	Off
LPC Interface							
LAD[3:0] / FWH[3:0]	Vcc3_3	High	High	High	High	Off	Off
LFRAME# / FWH[4]	Vcc3_3	High	High	High	High	Off	Off

Table 3-4. Power Plane and States for Output and I/O Signals for Mobile Configurations
(Sheet 2 of 4)

Signal Name	Power Plane	During PLTRST# ⁶ / RSMRST# ⁷	Immediately after PLTRST# ⁶ / RSMRST# ⁷	C3/C4	S1	S3 _{COLD} ¹³	S4/S5
LAN Connect and EEPROM Interface							
EE_CS	VccLAN3_3	Low	Running	Defined	Defined	Note 4	Note 4
EE_DOUT	VccLAN3_3	High	High	Defined	Defined	Note 4	Note 4
EE_SHCLK	VccLAN3_3	Low	Running	Defined	Defined	Note 4	Note 4
LAN_RSTSYN	VccLAN3_3	High	Low	Defined	Defined	Note 4	Note 4
LAN_TXD[2:0]	VccLAN3_3	Low	Low	Defined	Defined	Note 4	Note 4
IDE Interface							
DA[2:0]	Vcc3_3	Undefined	Undefined	Undefined	Undefined	Off	Off
DCS1#, DCS3#	Vcc3_3	High	High	High	High	Off	Off
DD[15:8], DD[6:0]	Vcc3_3	High-Z	High-Z	Defined	High-Z	Off	Off
DD[7]	Vcc3_3	Low	Low	Defined	Low	Off	Off
DDACK#	Vcc3_3	High	High	High	High	Off	Off
DIOR#, DIOW#	Vcc3_3	High	High	High	High	Off	Off
SATA Interface							
SATA[0]TXP, SATA[0]TXN SATA[2]TXP, SATA[2]TXN	Vcc3_3	High-Z	High-Z	Defined	Defined	Off	Off
SATALED#	Vcc3_3	High-Z	High-Z	Defined	Defined	Off	Off
SATARBIAS	Vcc3_3	High-Z	High-Z	Defined	Defined	Off	Off
Interrupts							
PIRQ[A:H]#	Vcc3_3	High-Z	High-Z	Defined	High-Z	Off	Off
SERIRQ	Vcc3_3	High-Z	High-Z	Running	High-Z	Off	Off
USB Interface							
USBP[7:0][P,N]	VccSus3_3	Low	Low	Low	Low	Low	Low
USBBIAS	VccSus3_3	High-Z	High-Z	Defined	Defined	Defined	Defined
Power Management							
PLTRST#	VccSus3_3	Low	High	High	High	Low	Low
SLP_S3#	VccSus3_3	Low	High	High	High	Low	Low
SLP_S4#	VccSus3_3	Low	High	High	High	High	Low
SLP_S5#	VccSus3_3	Low	High	High	High	High	Low ¹⁰
STP_PCI#	Vcc3_3	High	High	Defined	High	Low	Low
STP_CPU#	Vcc3_3	High	High	Low	High	Low	Low
SUS_STAT#	VccSus3_3	Low	High	High	High	Low	Low
DPRSLPVR	Vcc3_3	Low	Low	Low/High ⁵	High	Off	Off

**Table 3-4. Power Plane and States for Output and I/O Signals for Mobile Configurations
(Sheet 3 of 4)**

Signal Name	Power Plane	During PLTRST# ⁶ / RSMRST# ⁷	Immediately after PLTRST# ⁶ / RSMRST# ⁷	C3/C4	S1	S3 _{COLD} ¹³	S4/S5
DPRSTP#	Vcc3_3	High	High	Low/High ⁵	High	Off	Off
SUSCLK	VccSus3_3	Low	Running				
Processor Interface							
A20M#	V_CPU_IO	See Note 1	See Note 1	Defined	High	Off	Off
CPUPWRGD	Vcc3_3	See Note 3	High-Z	High-Z	High-Z	Off	Off
CPUSLP#	V_CPU_IO	High	High	High	Defined	Off	Off
IGNNE#	V_CPU_IO	See Note 1	See Note 1	High	High	Off	Off
INIT#	V_CPU_IO	High	High	High	High	Off	Off
INIT3_3V#	Vcc3_3	High	High	High	High	Off	Off
INTR	V_CPU_IO	See Note 8	See Note 8	Defined	Low	Off	Off
NMI	V_CPU_IO	See Note 8	See Note 8	Defined	Low	Off	Off
SMI#	V_CPU_IO	High	High	Defined	High	Off	Off
STPCLK#	V_CPU_IO	High	High	Low	Low	Off	Off
DPSLP#	V_CPU_IO	High	High	High/Low	High	Off	Off
SMBus Interface							
SMBCLK, SMBDATA	VccSus3_3	High-Z	High-Z	Defined	Defined	Defined	Defined
System Management Interface							
SMLINK[1:0]	VccSus3_3	High-Z	High-Z	Defined	Defined	Defined	Defined
LINKALERT#	VccSus3_3	High-Z	High-Z	Defined	Defined	Defined	Defined
Miscellaneous Signals							
SPKR	Vcc3_3	High-Z with Internal Pull-down	Low	Defined	Defined	Off	Off
AC '97 Interface							
ACZ_RST#	VccSus3_3	Low	Low	High	Cold Reset Bit (High)	Low	Low
ACZ_SDOUT	Vcc3_3	Low	Running	Running	Low	Off	Off
ACZ_SYNC	Vcc3_3	Low	Running	Running	Low	Off	Off

**Table 3-4. Power Plane and States for Output and I/O Signals for Mobile Configurations
(Sheet 4 of 4)**

Signal Name	Power Plane	During PLTRST# ⁶ / RSMRST# ⁷	Immediately after PLTRST# ⁶ / RSMRST# ⁷	C3/C4	S1	S3 _{COLD} ¹³	S4/S5
Intel High Definition Audio Interface							
ACZ_RST#	VccSus3_3	Low	Low ¹¹	High	TBD	Low	Low
ACZ_SDOOUT	Vcc3_3	High-Z with Internal Pull-down	Running	Running	Low	Off	Off
ACZ_SYNC	Vcc3_3	High-Z with Internal Pull-down	Running	Running	Low	Off	Off
ACZ_BIT_CLK	Vcc3_3	High-Z with Internal Pull-down	Low ¹¹	Running	Low	Off	Off
Unmultiplexed GPIO Signals							
GPO[19]	Vcc3_3	High	High	Defined	Defined	Off	Off
GPO[21]	Vcc3_3	High	High	Defined	Defined	Off	Off
GPO[23]	Vcc3_3	Low	Low	Defined	Defined	Off	Off
GPIO[24]	VccSus3_3	High	High	Defined	Defined	Defined	Defined
GPIO[25]	VccSus3_3	High	High ⁹	Defined	Defined	Defined	Defined
GPIO[28:27]	VccSus3_3	High	High	Defined	Defined	Defined	Defined
GPIO[34:33]	Vcc3_3	High	High	Defined	Defined	Off	Off

NOTES:

1. ICH6 drives these signals Low before PWROK rising and High after the processor reset.
2. GPIO[18] will toggle at a frequency of approximately 1 Hz when the ICH6 comes out of reset
3. CPUPWRGD is an open-drain output that represents a logical AND of the ICH6's VRMPWRGD and PWROK signals, and thus will be driven low by ICH6 when either VRMPWRGD or PWROK are inactive. During boot, or during a hard reset with power cycling, CPUPWRGD will be expected to transition from low to High-Z.
4. LAN Connect and EEPROM signals will either be "Defined" or "Off" in S3-S5 states depending upon whether or not the LAN power planes are active.
5. The state of the DPRSLPVR and DPRSTP# signals in C4 are high if Deeper Sleep is enabled or low if it is disabled.
6. The states of Vcc3_3 signals are taken at the times during PLTRST# and Immediately after PLTRST#.
7. The states of VccSus3_3 signals are taken at the times during RSMRST# and Immediately after RSMRST#.
8. ICH6 drives these signals Low before PWROK rising and Low after the processor reset.
9. GPIO[25] transitions from pulled high internally to actively driven following the de-assertion of the RSMRST# pin.
10. SLP_S5# signals will be high in the S4 state.
11. Low until Intel High Definition Audio Controller Reset bit set (D27:F0:Offset HDBAR+08h:bit 0), at which time ACZ_RST# will be High and ACZ_BIT_CLK will be Running.
12. PETp/n[4:1] high until port is enabled by software.
13. In S3_{HOT}, signal states are platform implementation specific, as some external components and interfaces may be powered when the ICH6 is in the S3_{HOT} state.

3.4 Power Planes for Input Signals

Table 3-5 and Table 3-6 shows the power plane associated with each input signal, as well as what device drives the signal at various times. Valid states include:

- High
- Low
- Static: Will be high or low, but will not change
- Driven: Will be high or low, and is allowed to change
- Running: For input clocks

Table 3-5. Power Plane for Input Signals for Desktop Configurations (Sheet 1 of 3)

Signal Name	Power Well	Driver During Reset	S1	S3COLD ¹	S4/S5
A20GATE	Vcc3_3	External Microcontroller	Static	Low	Low
ACZ_BIT_CLK (AC '97 Mode)	Vcc3_3	AC '97 Codec	Low	Low	Low
ACZ_SDIN[2:0] (AC '97 Mode)	VccSus3_3	AC '97 Codec	Low	Low	Low
ACZ_SDIN[2:0] (Intel High Definition Audio Mode)	VccSus3_3	Intel High Definition Audio Codec	Low	Low	Low
CLK14	Vcc3_3	Clock Generator	Running	Low	Low
CLK48	Vcc3_3	Clock Generator	Running	Low	Low
DDREQ	Vcc3_3	IDE Device	Static	Low	Low
DMI_CLKP, DMI_CLKN	Vcc3_3	Clock Generator	Running	Low	Low
EE_DIN	VccSus3_3	EEPROM Component	Driven	Driven	Driven
FERR#	V_CPU_IO	Processor	Static	Low	Low
GPI[6]	Vcc3_3	External Device or External Pull-up/Pull-down	Driven	Off	Off
GPI[7]	Vcc3_3	External Device or External Pull-up/Pull-down	Driven	Off	Off
GPI[8]	VccSus3_3	External Device or External Pull-up/Pull-down	Driven	Driven	Driven
GPI[12]	Vcc3_3	External Device or External Pull-up/Pull-down	Driven	Driven	Driven
GPI[13]	VccSus3_3	External Device or External Pull-up/Pull-down	Driven	Driven	Driven
PERp[1], PERn[1] PERp[2], PERn[2] PERp[3], PERn[3] PERp[4], PERn[4]	Vcc3_3	PCI Express* Device	Driven	Driven	Driven

Table 3-5. Power Plane for Input Signals for Desktop Configurations (Sheet 2 of 3)

Signal Name	Power Well	Driver During Reset	S1	S3 _{COLD} ¹	S4/S5
DMI[0]RXP, DMI[0]RXN DMI[1]RXP, DMI[1]RXN DMI[2]RXP, DMI[2]RXN DMI[3]RXP, DMI[3]RXN	Vcc3_3	(G)MCH	Driven	Low	Low
IDEIRQ	Vcc3_3	IDE	Static	Low	Low
INTRUDER#	VccRTC	External Switch	Driven	Driven	Driven
INTVRMEN	VccRTC	External Pull-up or Pull-down	Driven	Driven	Driven
IORDY	Vcc3_3	IDE Device	Static	Low	Low
LAN_CLK	VccSus3_3	LAN Connect Component	Driven	Driven	Driven
LAN_RST#	VccSus3_3	External RC Circuit	High	High	High
LAN_RXD[2:0]	VccSus3_3	LAN Connect Component	Driven	Driven	Driven
LDRQ0#	Vcc3_3	LPC Devices	High	Low	Low
LDRQ1#	Vcc3_3	LPC Devices	High	Low	Low
MCH_SYNC#	Vcc3_3	(G)MCH	Driven	Low	Low
OC[7:0]#	VccSus3_3	External Pull-ups	Driven	Driven	Driven
PCICLK	Vcc3_3	Clock Generator	Running	Low	Low
PME#	VccSus3_3	Internal Pull-up	Driven	Driven	Driven
PWRBTN#	VccSus3_3	Internal Pull-up	Driven	Driven	Driven
PWROK	VccRTC	System Power Supply	Driven	Low	Low
RCIN#	Vcc3_3	External Microcontroller	High	Low	Low
REQ[6:0]#	Vcc3_3	PCI Master	Driven	Low	Low
RI#	VccSus3_3	Serial Port Buffer	Driven	Driven	Driven
RSMRST#	VccRTC	External RC Circuit	High	High	High
RTCST#	VccRTC	External RC Circuit	High	High	High
SATA_CLKP, SATA_CLKN	Vcc3_3	Clock Generator	Running	Low	Low
SATA[0]RXP, SATA[0]RXN SATA[1]RXP, SATA[1]RXN SATA[2]RXP, SATA[2]RXN SATA[3]RXP, SATA[3]RXN	Vcc3_3	SATA Drive	Driven	Driven	Driven
SATARBIAS#	Vcc3_3	External Pull-down	Driven	Driven	Driven
SATA[3:0]GP / GPI[31:29,26]	Vcc3_3	External Device or External Pull-up/Pull-down	Driven	Driven	Driven
SERR#	Vcc3_3	PCI Bus Peripherals	High	Low	Low

Table 3-5. Power Plane for Input Signals for Desktop Configurations (Sheet 3 of 3)

Signal Name	Power Well	Driver During Reset	S1	S3 _{COLD} ¹	S4/S5
SMBALERT#	VccSus3_3	External Pull-up	Driven	Driven	Driven
SYS_RESET#	VccSus3_3	External Circuit	Driven	Driven	Driven
THRM#	Vcc3_3	Thermal Sensor	Driven	Low	Low
THRMTRIP#	V_CPU_IO	Thermal Sensor	Driven	Low	Low
TP[0]	VccSus3_3	External Pull-up	High	High	High
TP[3]	VccSus3_3	Internal Pull-up	High	High	High
USBBIAS#	VccSus3_3	External Pull-down	Driven	Driven	Driven
VRMPWRGD	Vcc3_3	Processor Voltage Regulator	High	Low	Low
WAKE#	VccSus3_3	External Pull-up	Driven	Driven	Driven

NOTES:

1. In S3_{HOT}, signal states are platform implementation specific, as some external components and interfaces may be powered when the ICH6 is in the S3_{HOT} state.

Table 3-6. Power Plane for Input Signals for Mobile Configurations (Sheet 1 of 3)

Signal Name	Power Well	Driver During Reset	C3/C4	S1	S3 _{COLD} ¹	S4/S5
A20GATE	Vcc3_3	External Microcontroller	Static	Static	Low	Low
ACZ_BIT_CLK (AC '97 mode)	Vcc3_3	AC '97 Codec	Driven	Low	Low	Low
ACZ_SDIN[2:0] (AC '97 mode)	VccSus3_3	AC '97 Codec	Driven	Low	Low	Low
ACZ_SDIN[2:0] (Intel High Definition Audio mode)	VccSus3_3	Intel High Definition Audio Codec	Driven	Low	Low	Low
BMBUSY#	Vcc3_3	Graphics Component [(G)MCH]	Driven	High	Low	Low
BATLOW#	VccSus3_3	Power Supply	High	High	High	High
CLK14	Vcc3_3	Clock Generator	Running	Running	Low	Low
CLK48	Vcc3_3	Clock Generator	Running	Running	Low	Low
DDREQ	Vcc3_3	IDE Device	Driven	Static	Low	Low
DMI_CLKP DMI_CLKN	Vcc3_3	Clock Generator	Running	Running	Low	Low
EE_DIN	VccLAN3_3	EEPROM Component	Driven	Driven	Note 2	Note 2
FERR#	V_CPU_IO	Processor	Static	Static	Low	Low
GPI[7]	Vcc3_3	External Device or External Pull-up/Pull-down	Driven	Driven	Off	Off
GPI[8]	VccSus3_3	External Device or External Pull-up/Pull-down	Driven	Driven	Driven	Driven
GPI[12]	Vcc3_3	External Device or External Pull-up/Pull-down	Driven	Driven	Driven	Driven

Table 3-6. Power Plane for Input Signals for Mobile Configurations (Sheet 2 of 3)

Signal Name	Power Well	Driver During Reset	C3/C4	S1	S3COLD ¹	S4/S5
GPI[13]	VccSus3_3	External Device or External Pull-up/Pull-down	Driven	Driven	Driven	Driven
GPI[29]	Vcc3_3	External Device or External Pull-up/Pull-down	Driven	Driven	Driven	Driven
GPI[31]	Vcc3_3	External Device or External Pull-up/Pull-down	Driven	Driven	Driven	Driven
PERp[1], PERn[1] PERp[2], PERn[2] PERp[3], PERn[3] PERp[4], PERn[4]	Vcc3_3	PCI Express* Device	Driven	Driven	Driven	Driven
DMI[0]RXP, DMI[0]RXN DMI[1]RXP, DMI[1]RXN DMI[2]RXP, DMI[2]RXN DMI[3]RXP, DMI[3]RXN	Vcc3_3	(G)MCH	Driven	Driven	Low	Low
IDEIRQ	Vcc3_3	IDE	Driven	Static	Low	Low
INTRUDER#	VccRTC	External Switch	Driven	Driven	Driven	Driven
INTVRMEN	VccRTC	External Pull-up or Pull-down	Driven	Driven	Driven	Driven
IORDY	Vcc3_3	IDE Device	Static	Static	Low	Low
LAN_CLK	VccLAN3_3	LAN Connect Component	Driven	Driven	Note 2	Note 2
LAN_RST#	VccSus3_3	Power Supply	High	High	Static	Static
LAN_RXD[2:0]	VccLAN3_3	LAN Connect Component	Driven	Driven	Note 2	Note 2
LDRQ0#	Vcc3_3	LPC Devices	Driven	High	Low	Low
LDRQ1#	Vcc3_3	LPC Devices	Driven	High	Low	Low
MCH_SYNC#	Vcc3_3	(G)MCH	Driven	Driven	Low	Low
OC[7:0]#	VccSus3_3	External Pull-ups	Driven	Driven	Driven	Driven
PCICLK	Vcc3_3	Clock Generator	Running	Running	Low	Low
PME#	VccSus3_3	Internal Pull-up	Driven	Driven	Driven	Driven
PWRBTN#	VccSus3_3	Internal Pull-up	Driven	Driven	Driven	Driven
PWROK	VccRTC	System Power Supply	Driven	Driven	Low	Low
RCIN#	Vcc3_3	External Microcontroller	High	High	Low	Low
REQ[6:0]#	Vcc3_3	PCI Master	Driven	Driven	Low	Low
Rl#	VccSus3_3	Serial Port Buffer	Driven	Driven	Driven	Driven
RSMRST#	VccRTC	External RC Circuit	High	High	High	High
RTCST#	VccRTC	External RC Circuit	High	High	High	High

Table 3-6. Power Plane for Input Signals for Mobile Configurations (Sheet 3 of 3)

Signal Name	Power Well	Driver During Reset	C3/C4	S1	S3 _{COLD} ¹	S4/S5
SATA_CLKP, SATA_CLKN	Vcc3_3	Clock Generator	Running	Running	Low	Low
SATA[0]RXP, SATA[0]RXN SATA[2]RXP, SATA[2]RXN	Vcc3_3	SATA Drive	Driven	Driven	Driven	Driven
SATARBIAS#	Vcc3_3	External Pull-Down	Driven	Driven	Driven	Driven
SATA[2,0]GP	Vcc3_3	External Device or External Pull-up/Pull-down	Driven	Driven	Driven	Driven
SERR#	Vcc3_3	PCI Bus Peripherals	Driven	High	Low	Low
SMBALERT#	VccSus3_3	External Pull-up	Driven	Driven	Driven	Driven
SYS_RESET#	VccSus3_3	External Circuit	Driven	Driven	Driven	Driven
THRM#	Vcc3_3	Thermal Sensor	Driven	Driven	Low	Low
THRMTRIP#	V_CPU_IO	Thermal Sensor	Driven	Driven	Low	Low
TP[3]	VccSus3_3	Internal Pull-up	High	High	High	High
USBRBIAS#	VccSus3_3	External Pull-down	Driven	Driven	Driven	Driven
VRMPWRGD	Vcc3_3	Processor Voltage Regulator	Driven	Driven	Low	Low
WAKE#	VccSus3_3	External Pull-up	Driven	Driven	Driven	Driven

NOTES:

1. In S3_{HOT}, signal states are platform implementation specific, as some external components and interfaces may be powered when the ICH6 is in the S3_{HOT} state.
2. LAN Connect and EEPROM signals will either be “Driven” or “Low” in S3–S5 states depending upon whether or not the LAN power planes are active.

§

4 System Clock Domains

Table 4-1 shows the ICH6 and system clock domains. Figure 4-1 and Figure 4-2 shows the assumed connection of the various system components, including the clock generator in both desktop and mobile systems. For complete details of the system clocking solution, refer to the system's clock generator component specification.

Table 4-1. Intel® ICH6 and System Clock Domains

Clock Domain	Frequency	Source	Usage
Intel® ICH6 SATA_CLKP, SATA_CLKN	100 MHz	Main Clock Generator	Differential clock pair used for SATA.
ICH6 DMI_CLKP, DMI_CLKN	100 MHz	Main Clock Generator	Differential clock pair used for DMI.
ICH6 PCICLK	33 MHz	Main Clock Generator	Free-running PCI Clock to Intel® ICH6. This clock remains on during S0 and S1 (in desktop) state, and is expected to be shut off during S3 or below in desktop configurations or S1 or below in mobile configurations.
System PCI	33 MHz	Main Clock Generator	PCI Bus, LPC I/F. These only go to external PCI and LPC devices. Will stop based on CLKRUN# (and STP_PCI#) in mobile configurations.
ICH6 CLK48	48.000 MHz	Main Clock Generator	Super I/O, USB controllers. Expected to be shut off during S3 or below in desktop configurations or S1 or below in mobile configurations.
ICH6 CLK14	14.31818 MHz	Main Clock Generator	Used for ACPI timer and Multimedia Timers. Expected to be shut off during S3 or below in desktop configurations or S1 or below in mobile configurations.
ICH6 ACZ_BIT_CLK	12.288 MHz	AC '97 Codec	AC-link. Generated by AC '97 Codec. Can be shut by codec in D3. Expected to be shut off during S3 or below in desktop configurations or S1 or below in mobile configurations. NOTE: For use only in AC '97 mode.
LAN_CLK	5 to 50 MHz	LAN Connect Component	Generated by the LAN Connect component. Expected to be shut off during S3 or below in desktop configurations or S1 or below in mobile configurations.

Figure 4-1. Desktop Conceptual System Clock Diagram

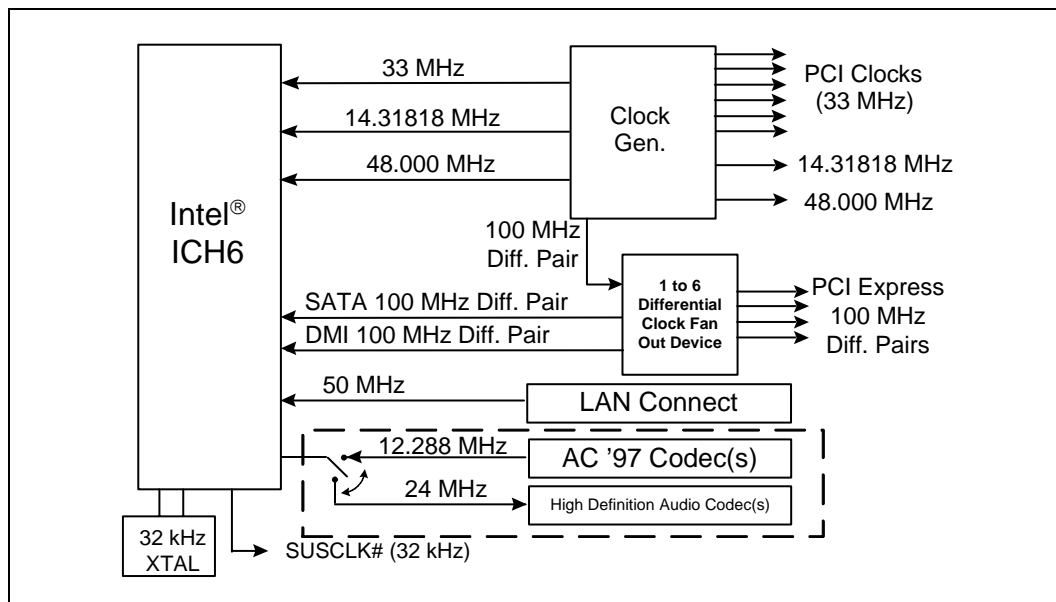
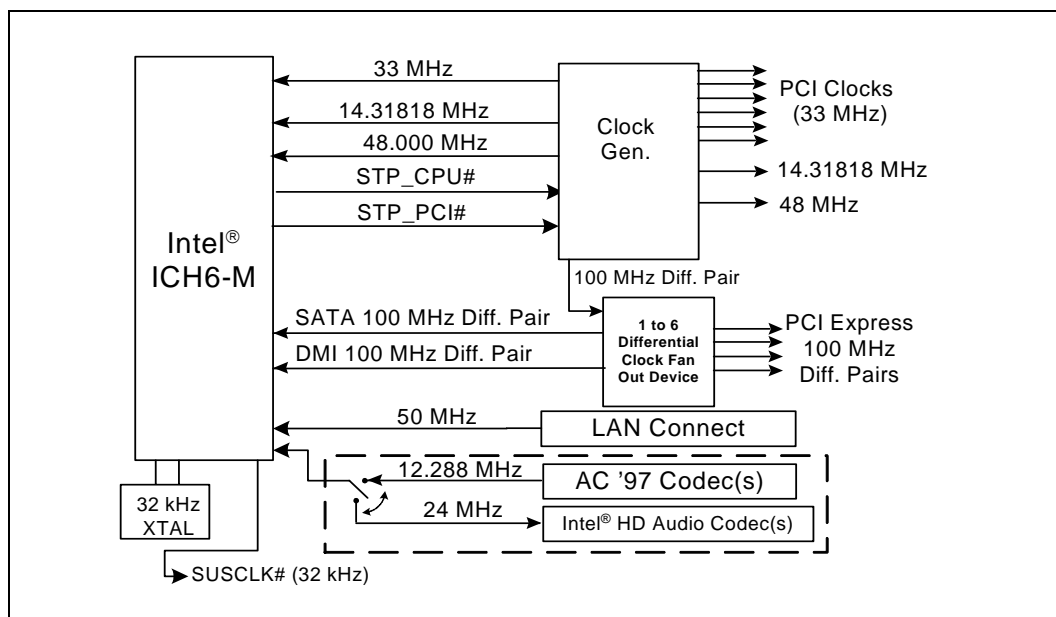

Figure 4-2. Mobile Conceptual Clock Diagram



§

5 Functional Description

This chapter describes the functions and interfaces of the ICH6 Family.

5.1 PCI-to-PCI Bridge (D30:F0)

The PCI-to-PCI bridge resides in PCI Device 30, Function 0 on bus #0. This portion of the ICH6 implements the buffering and control logic between PCI and Direct Media Interface (DMI). The arbitration for the PCI bus is handled by this PCI device. The PCI decoder in this device must decode the ranges for the DMI. All register contents are lost when core well power is removed.

Direct Media Interface (DMI) is the chip-to-chip connection between the Memory Controller Hub / Graphics and Memory Controller Hub ((G)MCH) and I/O Controller Hub 6 (ICH6). This high-speed interface integrates advanced priority-based servicing allowing for concurrent traffic and true isochronous transfer capabilities. Base functionality is completely software transparent permitting current and legacy software to operate normally.

In order to provide for true isochronous transfers and configurable Quality of Service (QoS) transactions, the ICH6 supports two virtual channels on DMI: VC0 and VC1. These two channels provide a fixed arbitration scheme where VC1 is always the highest priority. VC0 is the default conduit of traffic for DMI and is always enabled. VC1 must be specifically enabled and configured at both ends of the DMI link (i.e., the ICH6 and (G)MCH).

Configuration registers for DMI, virtual channel support, and DMI active state power management (ASPM) are in the RCRB space in the Chipset Configuration Registers ([Section 7](#)).

5.1.1 PCI Bus Interface

The ICH6 PCI interface provides a 33 MHz, *PCI Local Bus Specification, Revision 2.3*-compliant implementation. All PCI signals are 5 V tolerant (except PME#). The ICH6 integrates a PCI arbiter that supports up to seven external PCI bus masters in addition to the internal ICH6 requests.

5.1.2 PCI Bridge As an Initiator

The bridge initiates cycles on the PCI bus when granted by the PCI arbiter. The bridge generates the cycle types shown in [Table 5-1](#).

Table 5-1. PCI Bridge Initiator Cycle Types

Command	C/BE#	Notes
I/O Read/Write	2h/3h	Non-posted
Memory Read/Write	6h/7h	Writes are posted
Configuration Read/Write	Ah/Bh	Non-posted
Special Cycles	1h	Posted

5.1.2.1 Memory Reads and Writes

The bridge bursts memory writes on PCI that are received as a single packet from DMI. The bridge will perform write combining if BPC.WCE (D30:F0:Offset 4Ch:bit 31) is set.

5.1.2.2 I/O Reads and Writes

The bridge generates single DW I/O read and write cycles. When the cycle completes on PCI bus, the bridge generates a corresponding completion on DMI. If the cycle is retried, the cycle is kept in the downbound queue and may be passed by a postable cycle.

5.1.2.3 Configuration Reads and Writes

The bridge generates single DW configuration read and write cycles. When the cycle completes on PCI bus, the bridge generates a corresponding completion. If the cycle is retried, the cycle is kept in the downbound queue and may be passed by a postable cycle.

5.1.2.4 Locked Cycles

The bridge propagates locks from DMI per the PCI specification. The PCI bridge implements bus lock, which means the arbiter will not grant to any agent except DMI while locked.

If a locked read results in a target or master abort, the lock is not established (as per the PCI specification). Agents north of the ICH6 must not forward a subsequent locked read to the bridge if they see the first one finish with a failed completion.

5.1.2.5 Target / Master Aborts

When a cycle initiated by the bridge is master/target aborted, the bridge will not re-attempt the same cycle. For multiple DW cycles, the bridge increments the address and attempts the next DW of the transaction. For all non-postable cycles, a target abort response packet is returned for each DW that was master or target aborted on PCI. The bridge drops posted writes that abort.

5.1.2.6 Secondary Master Latency Timer

The bridge implements a Master Latency Timer via the SLT register which, upon expiration, causes the de-assertion of FRAME# at the next legal clock edge when there is another active request to use the PCI bus.

5.1.2.7 Dual Address Cycle (DAC)

The bridge will issue full 64-bit dual address cycles for device memory-mapped registers above 4 GB.

5.1.2.8 Memory and I/O Decode to PCI

The PCI bridge in the ICH6 is a **subtractive decode agent**, which follows the following rules when forwarding a cycle from DMI to the PCI interface:

- The PCI bridge will **positively** decode any memory I/O address within its window registers, assuming PCICMD.MSE (D30:F0:Offset 04h:bit 1) is set for memory windows and PCICMD.IOSE (D30:F0:Offset 04h:bit 0) is set for I/O windows.
- The PCI bridge will **subtractively** decode any 64-bit memory address not claimed by another agent, assuming PCICMD.MSE (D30:F0:Offset 04h:bit 1) is set.
- The PCI bridge will **subtractively** decode any 16-bit I/O address not claimed by another agent assuming PCICMD.IOSE (D30:F0:Offset 04h:bit 0) set
- If BCTRL.IE (D30:F0:Offset 3Eh:bit 2) is set, the PCI bridge will **not positively** forward from primary to secondary called out ranges in the I/O window per PCI specification (I/O transactions addressing the last 768 bytes in each, 1-KB block: offsets 100h to 3FFh). The PCI bridge will still take them subtractively assuming the above rules.
- If BCTRL.VGAE (D30:F0:Offset 3Eh:bit 3) is set, the PCI bridge will **positively** forward from primary to secondary I/O and memory ranges as called out in the PCI bridge specification, assuming the above rules are met.

5.1.3 Parity Error Detection and Generation

PCI parity errors can be detected and reported. The following behavioral rules apply:

- When a parity error is detected on PCI, the bridge sets the SECSTS.DPE (D30:F0:Offset 1Eh:bit 15).
- If the bridge is a master and BCTRL.PERE (D30:F0:Offset 3Eh:bit 0) and one of the parity errors defined below is detected on PCI, then the bridge will set SECSTS.DPD (D30:F0:Offset 1Eh:bit 8) and will also generate an internal SERR#.
 - During a write cycle, the PERR# signal is active, or
 - A data parity error is detected while performing a read cycle
- If an address or command parity error is detected on PCI and PCICMD.SEE (D30:F0:Offset 04h:bit 8), BCTRL.PERE, and BCTRL.SEE (D30:F0:Offset 3Eh:bit 1) are all set, the bridge will set the PSTS.SSE (D30:F0:Offset 06h:bit 14) and generate an internal SERR#.
- If the PSTS.SSE is set because of an address parity error and the PCICMD.SEE is set, the bridge will generate an internal SERR#.
- When bad parity is detected from DMI, bad parity will be driven on all data the bridge.
- When an address parity error is detected on PCI, the PCI bridge will never claim the cycle. This is a slight deviation from the PCI bridge spec, which says that a cycle should be claimed if BCTRL.PERE is not set. However, DMI does not have a concept of address parity error, so claiming the cycle could result in the rest of the system seeing a bad transaction as a good transaction.

5.1.4 PCIRST#

The PCIRST# pin is generated under two conditions:

- PLTRST# active
- BCTRL.SBR (D30:F0:Offset 3Eh:bit 6) set to 1

The PCIRST# pin is in the resume well. PCIRST# should be tied to PCI bus agents, but not other agents in the system.

5.1.5 Peer Cycles

The following peer cycles are supported: PCI Express to PCI Express Graphics (writes only), PCI to PCI Express Graphics (writes only) and PCI to PCI.

Note: The ICH6's AC '97, IDE and USB controllers cannot perform peer-to-peer traffic.

5.1.6 PCI-to-PCI Bridge Model

From a software perspective, the ICH6 contains a PCI-to-PCI bridge. This bridge connects DMI to the PCI bus. By using the PCI-to-PCI bridge software model, the ICH6 can have its decode ranges programmed by existing plug-and-play software such that PCI ranges do not conflict with graphics aperture ranges in the Host controller.

5.1.7 IDSEL to Device Number Mapping

When addressing devices on the external PCI bus (with the PCI slots), the ICH6 asserts one address signal as an IDSEL. When accessing device 0, the ICH6 asserts AD16. When accessing Device 1, the ICH6 asserts AD17. This mapping continues all the way up to device 15 where the ICH6 asserts AD31. Note that the ICH6's internal functions (AC '97, Intel High Definition Audio, IDE, USB, SATA and PCI Bridge) are enumerated like they are off of a separate PCI bus (DMI) from the external PCI bus. The integrated LAN controller is Device 8 on the ICH6's PCI bus, and hence it uses AD[24] for IDSEL.

5.1.8 Standard PCI Bus Configuration Mechanism

The PCI Bus defines a slot based “configuration space” that allows each device to contain up to eight functions with each function containing up to 256, 8-bit configuration registers. The *PCI Local Bus Specification, Revision 2.3* defines two bus cycles to access the PCI configuration space: Configuration Read and Configuration Write. Memory and I/O spaces are supported directly by the processor. Configuration space is supported by a mapping mechanism implemented within the ICH6. The *PCI Local Bus Specification, Revision 2.3* defines two mechanisms to access configuration space, Mechanism 1 and Mechanism 2. The ICH6 only supports Mechanism 1.

Warning: Configuration writes to internal devices, when the devices are disabled, are illegal and may cause undefined results.

5.2 PCI Express* Root Ports (D28:F0,F1,F2,F3)

PCI Express is the next generation high performance general input/output architecture. PCI Express is a high speed, low voltage, serial pathway for two devices to communicate simultaneously by implementing dual unidirectional paths between two devices. PCI Express has been defined to be 100-percent compatible with conventional PCI compliant operating systems and their corresponding bus enumeration and configuration software. All PCI Express hardware elements have been defined with a PCI-compatible configuration space representation.

PCI Express replaces the device-based arbitration process of conventional PCI with flow-control - based link arbitration that allows data to pass up and down the link based upon traffic class priority. High priority is given to traffic classes that require guaranteed bandwidth such as isochronous transactions while room is simultaneously made for lower priority transactions to avoid bottlenecks.

The ICH6 provides 4 (x1) PCI Express ports with each port supporting up to 5 Gb/s concurrent bandwidth (2.5 Gb/s in each direction). These all reside in device 28, and take function 0 – 3. Port 1 is function 0, port 2 is function 1, port 3 is function 2, and port 4 is function 3.

5.2.1 Interrupt Generation

The root port generates interrupts on behalf of Hot-Plug and power management events, when enabled. These interrupts can either be pin based, or can be MSIs, when enabled.

When an interrupt is generated via the legacy pin, the pin is internally routed to the ICH6 interrupt controllers. The pin that is driven is based upon the setting of the chipset configuration registers. Specifically, the chipset configuration registers used are the D28IP (Base address + 310Ch) and D28IR (Base address + 3146h) registers.

The following table summarizes interrupt behavior for MSI and wire-modes. In the table “bits” refers to the Hot-Plug and PME interrupt bits.

Table 5-2. MSI vs. PCI IRQ Actions

Interrupt Register	Wire-Mode Action	MSI Action
All bits 0	Wire inactive	No action
One or more bits set to 1	Wire active	Send message
One or more bits set to 1, new bit gets set to 1	Wire active	Send message
One or more bits set to 1, software clears some (but not all) bits	Wire active	Send message
One or more bits set to 1, software clears all bits	Wire inactive	No action
Software clears one or more bits, and one or more bits are set on the same clock	Wire active	Send message

5.2.2 Power Management

5.2.2.1 S3/S4/S5 Support

Software initiates the transition to S3/S4/S5 by performing an I/O write to the Power Management Control register in the ICH6. After the I/O write completion has been returned to the processor, each root port will send a PME_Turn_Off TLP (Transaction Layer Packet) message on its downstream link. The device attached to the link will eventually respond with a PME_TO_Ack TLP message followed by sending a PM_Enter_L23 DLLP (Data Link Layer Packet) request to enter the L2/L3 Ready state. When all of the ICH6 root ports links are in the L2/L3 Ready state, the ICH6 power management control logic will proceed with the entry into S3/S4/S5.

Prior to entering S3, software is required to put each device into D3_{HOT}. When a device is put into D3_{HOT} it will initiate entry into a L1 link state by sending a PM_Enter_L1 DLLP. Thus under normal operating conditions when the root ports send the PME_Turn_Off message the link will be in state L1. However, when the root port is instructed to send the PME_Turn_Off message, it will send it whether or not the link was in L1. Endpoints attached to ICH6 can make no assumptions about the state of the link prior to receiving a PME_Turn_Off message.

5.2.2.2 Resuming from Suspended State

The root port contains enough circuitry in the resume well to detect a wake event thru the WAKE# signal and to wake the system. When WAKE# is detected asserted, an internal signal is sent to the power management controller of the ICH6 to cause the system to wake up. This internal message is not logged in any register, nor is an interrupt/GPE generated due to it.

5.2.2.3 Device Initiated PM_PME Message

When the system has returned to a working state from a previous low power state, a device requesting service will send a PM_PME message continuously, until acknowledge by the root port. The root port will take different actions depending upon whether this is the first PM_PME has been received, or whether a previous message has been received but not yet serviced by the operating system.

If this is the first message received (RSTS.PS - D28:F0/F1/F2/F3:Offset 60h:bit 16 is cleared), the root port will set RSTS.PS, and log the PME Requester ID into RSTS.RID (D28:F0/F1/F2/F3:Offset 60h:bits 15:0). If an interrupt is enabled via RCTL.PIE (D28:F0/F1/F2/F3:Offset 5Ch:bit 3), an interrupt will be generated. This interrupt can be either a pin or an MSI if MSI is enabled via MC.MSIE (D28:F0/F1/F2/F3:Offset 82h:bit 0). See [Section 5.2.2.4](#) for SMI/SCI generation.

If this is a subsequent message received (RSTS.PS is already set), the root port will set RSTS.PP (D28:F0/F1/F2/F3:Offset 60h:bit 17) and log the PME Requester ID from the message in a hidden register. No other action will be taken.

When the first PME event is cleared by software clearing RSTS.PS, the root port will set RSTS.PS, clear RSTS.PP, and move the requester ID from the hidden register into RSTS.RID.

If RCTL.PIE is set, generate an interrupt. If RCTL.PIE is not set, send over to the power management controller so that a GPE can be set. If messages have been logged (RSTS.PS is set), and RCTL.PIE is later written from a 0 to a 1, and interrupt must be generated. This last condition handles the case where the message was received prior to the operating system re-enabling interrupts after resuming from a low power state.

5.2.2.4 SMI/SCI Generation

Interrupts for power management events are not supported on legacy operating systems. To support power management on non-PCI Express aware operating systems, PM events can be routed to generate SCI. To generate SCI, MPC.PMCE must be set. When set, a power management event will cause SMSCS.PMCS (D28:F0/F1/F2/F3:Offset DCh:bit 31) to be set.

Additionally, BIOS workarounds for power management can be supported by setting MPC.PMME (D28:F0/F1/F2/F3:Offset D8h:bit 0). When this bit is set, power management events will set SMSCS.PMMS (D28:F0/F1/F2/F3:Offset DCh:bit 0), and SMI # will be generated. This bit will be set regardless of whether interrupts or SCI is enabled. The SMI# may occur concurrently with an interrupt or SCI.

5.2.3 SERR# Generation

SERR# may be generated via two paths; through PCI mechanisms involving bits in the PCI header, or through PCI Express mechanisms involving bits in the PCI Express capability structure.

Figure 5-1. Generation of SERR# to Platform

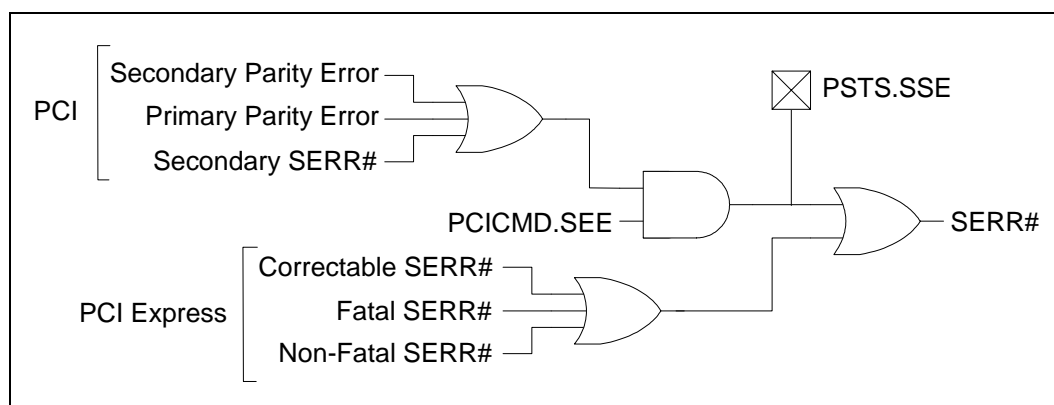

5.2.4 Hot-Plug

Each root port implements a Hot-Plug controller which performs the following:

- Messages to turn on / off / blink LEDs
- Presence and attention button detection
- Interrupt generation

The root port only allows Hot-Plug with modules (e.g., ExpressCard*). Edge-connector based Hot-Plug is not supported.

5.2.4.1 Presence Detection

When a module is plugged in and power is supplied, the physical layer will detect the presence of the device, and the root port sets SLSTS.PDS (D28:F0/F1/F2/F3:Offset 5Ah:bit 6) and SLSTS.PDC (D28:F0/F1/F2/F3:Offset 6h:bit 3). If SLCTL.PDE (D28:F0/F1/F2/F3:Offset 58h:bit 3) and SLCTL.HPE (D28:F0/F1/F2/F3:Offset 58h:bit 5) are both set, the root port will also generate an interrupt.

When a module is removed (via the physical layer detection), the root port clears SLSTS.PDS and sets SLSTS.PDC. If SLCTL.PDE and SLCTL.HPE are both set, the root port will also generate an interrupt.

5.2.4.2 Message Generation

When system software writes to SLCTL.AIC (D28:F0/F1/F2/F3:Offset 58h:bits 7:6) or SLCTL.PIC (D28:F0/F1/F2/F3:Offset 58h:bits 9:8), the root port will send a message down the link to change the state of LEDs on the module.

Writes to these fields are non-postable cycles, and the resulting message is a postable cycle. When receiving one of these writes, the root port performs the following:

- Changes the state in the register
- Generates a completion into the upstream queue
- Formulates a message for the downstream port if the field is written to regardless of if the field changed
- Generates the message on the downstream port
- When the last message of a command is transmitted, sets SLSTS.CCE (D28:F0/F1/F2/F3:Offset 58h:bit 4) to indicate the command has completed. If SLCTL.CCE and SLCTL.HPE (D28:F0/F1/F2/F3:Offset 58h:bit 5) are set, the root port generates an interrupt.

The command completed register (SLSTS.CC) applies only to commands issued by software to control the Attention Indicator (SLCTL.AIC), Power Indicator (SLCTL.PIC), or Power Controller (SLCTL.PCC). However, writes to other parts of the Slot Control Register would invariably end up writing to the indicators and power controller fields. Hence, any write to the Slot Control Register is considered a command and if enabled, will result in a command complete interrupt. The only exception to this rule is a write to disable the command complete interrupt which will not result in a command complete interrupt.

A single write to the Slot Control register is considered to be a single command, and hence receives a single command complete, even if the write affects more than one field in the Slot Control Register.

5.2.4.3 Attention Button Detection

When an attached device is ejected, an attention button could be pressed by the user. This attention button press will result in a the PCI Express message “Attention_Button_Pressed” from the device. Upon receiving this message, the root port will set SLSTS.ABP (D28:F0/F1/F2/F3:Offset 5Ah:bit 0).

If SLCTL.ABE (D28:F0/F1/F2/F3:Offset 58h:bit 0) and SLCTL.HPE (D28:F0/F1/F2/F3:Offset 58h:bit 5) are set, the Hot-Plug controller will also generate an interrupt. The interrupt is generated on an edge-event. For example, if SLSTS.ABP is already set, a new interrupt will not be generated.

5.2.4.4 SMI/SCI Generation

Interrupts for Hot-Plug events are not supported on legacy operating systems. To support Hot-Plug on non-PCI Express aware operating systems, Hot-Plug events can be routed to generate SCI. To generate SCI, MPC.HPCE (D28:F0/F1/F2/F3:Offset D8h:bit 30) must be set. When set, enabled Hot-Plug events will cause SMSCS.HPCS (D28:F0/F1/F2/F3:Offset DCh:bit 30) to be set.

Additionally, BIOS workarounds for Hot-Plug can be supported by setting MPC.HPME (D28:F0/F1/F2/F3:Offset D8h:bit 1). When this bit is set, Hot-Plug events can cause SMI status bits in SMSCS to be set. Supported Hot-Plug events and their corresponding SMSCS bit are:

- Command Completed – SMSCS.HPCCM (D28:F0/F1/F2/F3:Offset DCh:bit 3)
- Presence Detect Changed – SMSCS.HPPDM (D28:F0/F1/F2/F3:Offset DCh:bit 1)
- Attention Button Pressed – SMSCS.HPABM (D28:F0/F1/F2/F3:Offset DCh:bit 2)

When any of these bits are set, SMI # will be generated. These bits are set regardless of whether interrupts or SCI is enabled for Hot-Plug events. The SMI# may occur concurrently with an interrupt or SCI.

5.3 LAN Controller (B1:D8:F0)

The ICH6's integrated LAN controller includes a 32-bit PCI controller that provides enhanced scatter-gather bus mastering capabilities and enables the LAN controller to perform high-speed data transfers over the PCI bus. Its bus master capabilities enable the component to process high level commands and perform multiple operations; this lowers processor utilization by off-loading communication tasks from the processor. Two large transmit and receive FIFOs of 3 KB each, help prevent data underruns and overruns while waiting for bus accesses. This enables the integrated LAN controller to transmit data with minimum interframe spacing (IFS).

The ICH6 integrated LAN controller can operate in either full-duplex or half-duplex mode. In full-duplex mode the LAN controller adheres with the *IEEE 802.3x Flow Control Specification*. Half duplex performance is enhanced by a proprietary collision reduction mechanism.

The integrated LAN controller also includes an interface to a serial (4-pin) EEPROM. The EEPROM provides power-on initialization for hardware and software configuration parameters.

From a software perspective, the integrated LAN controller appears to reside on the secondary side of the ICH6's virtual PCI-to-PCI bridge (see [Section 5.1.6](#)). This is typically Bus 1, but may be assigned a different number, depending upon system configuration.

The following summarizes the ICH6 LAN controller features:

- Compliance with Advanced Configuration and Power Interface and PCI Power Management standards
- Support for wake-up on interesting packets and link status change
- Support for remote power-up using Wake on LAN* (WOL) technology
- Deep power-down mode support
- Support of Wired for Management (WfM) Revision 2.0
- Backward compatible software with 82550, 82557, 82558 and 82559
- TCP/UDP checksum off load capabilities
- Support for Intel's Adaptive Technology

5.3.1 LAN Controller PCI Bus Interface

As a Fast Ethernet controller, the role of the ICH6 integrated LAN controller is to access transmitted data or deposit received data. The LAN controller, as a bus master device, initiates memory cycles via the PCI bus to fetch or deposit the required data.

To perform these actions, the LAN controller is controlled and examined by the processor via its control and status structures and registers. Some of these control and status structures reside in the LAN controller and some reside in system memory. For access to the LAN controller's Control/Status Registers (CSR), the LAN controller acts as a slave (in other words, a target device). The LAN controller serves as a slave also while the processor accesses the EEPROM.

5.3.1.1 Bus Slave Operation

The ICH6 integrated LAN controller serves as a target device in one of the following cases:

- Processor accesses to the LAN controller System Control Block (SCB) Control/Status Registers (CSR)
- Processor accesses to the EEPROM through its CSR
- Processor accesses to the LAN controller PORT address via the CSR
- Processor accesses to the MDI control register in the CSR

The size of the CSR memory space is 4 KB in the memory space and 64 bytes in the I/O space. The LAN controller treats accesses to these memory spaces differently.

Control/Status Register (CSR) Accesses

The integrated LAN controller supports zero wait-state single cycle memory or I/O mapped accesses to its CSR space. Separate BARs request 4 KB of memory space and 64 bytes of I/O space to accomplish this. Based on its needs, the software driver uses either memory or I/O mapping to access these registers. The LAN controller provides four valid KB of CSR space that include the following elements:

- System Control Block (SCB) registers
- PORT register
- EEPROM control register
- MDI control register
- Flow control registers

In the case of accessing the Control/Status Registers, the processor is the initiator and the LAN controller is the target.

Retry Premature Accesses

The LAN controller responds with a Retry to any configuration cycle accessing the LAN controller before the completion of the automatic read of the EEPROM. The LAN controller may continue to Retry any configuration accesses until the EEPROM read is complete. The LAN controller does not enforce the rule that the retried master must attempt to access the same address again in order to complete any delayed transaction. Any master access to the LAN controller after the completion of the EEPROM read is honored.

Error Handling

Data Parity Errors: The LAN controller checks for data parity errors while it is the target of the transaction. If an error was detected, the LAN controller always sets the Detected Parity Error bit in the PCI Configuration Status register, bit 15. The LAN controller also asserts PERR#, if the Parity Error Response bit is set (PCI Configuration Command register, bit 6). The LAN controller does not attempt to terminate a cycle in which a parity error was detected. This gives the initiator the option of recovery.

Target-Disconnect: The LAN controller prematurely terminate a cycle in the following cases:

- After accesses to its CSR
- After accesses to the configuration space

System Error: The LAN controller reports parity error during the address phase using the SERR# pin. If the SERR# Enable bit in the PCI Configuration Command register or the Parity Error Response bit are not set, the LAN controller only sets the Detected Parity Error bit (PCI Configuration Status register, bit 15). If SERR# Enable and Parity Error Response bits are both set, the LAN controller sets the Signaled System Error bit (PCI Configuration Status register, bit 14) as well as the Detected Parity Error bit and asserts SERR# for one clock.

The LAN controller, when detecting system error, claims the cycle if it was the target of the transaction and continues the transaction as if the address was correct.

Note: The LAN controller reports a system error for any error during an address phase, whether or not it is involved in the current transaction.

5.3.1.2 CLKRUN# Signal (Mobile Only)

The ICH6 receives a free-running 33 MHz clock. It does not stop based on the CLKRUN# signal and protocol. When the LAN controller runs cycles on the PCI bus, the ICH6 makes sure that the STP_PCI# signal is high indicating that the PCI clock will be running. This is to make sure that any PCI tracker does not get confused by transactions on the PCI bus with its PCI clock stopped.

5.3.1.3 PCI Power Management

Enhanced support for the power management standard, *PCI Local Bus Specification, Revision 2.3*, is provided in the ICH6 integrated LAN controller. The LAN controller supports a large set of wake-up packets and the capability to wake the system from a low power state on a link status change. The LAN controller enables the host system to be in a sleep state and remain virtually connected to the network.

After a power management event or link status change is detected, the LAN controller wakes the host system. The sections below describe these events, the LAN controller power states, and estimated power consumption at each power state.

The LAN controller contains power management registers for PCI, and implements four power states, D0 through D3, which vary from maximum power consumption at D0 to the minimum power consumption at D3. PCI transactions are only allowed in the D0 state, except for host accesses to the LAN controller's PCI configuration registers. The D1 and D2 power management states enable intermediate power savings while providing the system wake-up capabilities. In the D3_{COLD} state, the LAN controller can provide wake-up capabilities. Wake-up indications from the LAN controller are provided by the Power Management Event (PME#) signal.

5.3.1.4 PCI Reset Signal

The PCIRST# signal may be activated in one of the following cases:

- During S3–S5 states
- Due to a CF9h reset

If PME is enabled (in the PCI power management registers), PCIRST# assertion does not affect any PME related circuits (in other words, PCI power management registers and the wake-up packet would not be affected). While PCIRST# is active, the LAN controller ignores other PCI signals. The configuration of the LAN controller registers associated with ACPI wake events is not affected by PCIRST#.

The integrated LAN controller uses the PCIRST# or the PWROK signal as an indication to ignore the PCI interface. Following the de-assertion of PCIRST#, the LAN controller PCI Configuration Space, MAC configuration, and memory structure are initialized while preserving the PME# signal and its context.

5.3.1.5 Wake-Up Events

There are two types of wake-up events: “Interesting” Packets and Link Status Change. These two events are detailed below.

Note: If the Wake on LAN bit in the EEPROM is not set, wake-up events are supported only if the PME Enable bit in the Power Management Control/Status Register (PMCSR) is set. However, if the Wake on LAN bit in the EEPROM is set, and Wake on Magic Packet* or Wake on Link Status Change are enabled, the Power Management Enable bit is ignored with respect to these events. In the latter case, PME# would be asserted by these events.

“Interesting” Packet Event

In the power-down state, the LAN controller is capable of recognizing “interesting” packets. The LAN controller supports predefined and programmable packets that can be defined as any of the following:

- ARP Packets (with Multiple IP addresses)
- Direct Packets (with or without type qualification)
- Magic Packet
- Neighbor Discovery Multicast Address Packet (‘ARP’ in IPv6 environment)
- NetBIOS over TCP/IP (NBT) Query Packet (under IPv4)
- Internetwork Package Exchange* (IPX) Diagnostic Packet

This allows the LAN controller to handle various packet types. In general, the LAN controller supports programmable filtering of any packet in the first 128 bytes.

When the LAN controller is in one of the low power states, it searches for a predefined pattern in the first 128 bytes of the incoming packets. The only exception is the Magic Packet, which is scanned for the entire frame. The LAN controller classifies the incoming packets as one of the following categories:

- **No Match:** The LAN controller discards the packet and continues to process the incoming packets.
- **TCO Packet:** The LAN controller implements perfect filtering of TCO packets. After a TCO packet is processed, the LAN controller is ready for the next incoming packet. TCO packets are treated as any other wake-up packet and may assert the PME# signal if configured to do so.
- **Wake-up Packet:** The LAN controller is capable of recognizing and storing the first 128 bytes of a wake-up packet. If a wake-up packet is larger than 128 bytes, its tail is discarded by the LAN controller. After the system is fully powered-up, software has the ability to determine the cause of the wake-up event via the PMDR and dump the stored data to the host memory.

Magic Packets are an exception. The Magic Packets may cause a power management event and set an indication bit in the PMDR; however, it is not stored by the LAN controller for use by the system when it is woken up.

Link Status Change Event

The LAN controller link status indication circuit is capable of issuing a PME on a link status change from a valid link to an invalid link condition or vice versa. The LAN controller reports a PME link status event in all power states. If the Wake on LAN bit in the EEPROM is not set, the PME# signal is gated by the PME Enable bit in the PMCSR and the CSMA Configure command.

5.3.1.6 Wake on LAN* (Preboot Wake-Up)

The LAN controller enters Wake on LAN mode after reset if the Wake on LAN bit in the EEPROM is set. At this point, the LAN controller is in the D0u state. When the LAN controller is in Wake on LAN mode:

- The LAN controller scans incoming packets for a Magic Packet and asserts the PME# signal for 52 ms when a 1 is detected in Wake on LAN mode.
- The Activity LED changes its functionality to indicate that the received frame passed Individual Address (IA) filtering or broadcast filtering.
- The PCI Configuration registers are accessible to the host.

The LAN controller switches from Wake on LAN mode to the D0a power state following a setup of the Memory or I/O Base Address Registers in the PCI Configuration space.

5.3.2 Serial EEPROM Interface

The serial EEPROM stores configuration data for the ICH6 integrated LAN controller and is a serial in/serial out device. The LAN controller supports a 64-register or 256-register size EEPROM and automatically detects the EEPROM's size. The EEPROM should operate at a frequency of at least 1 MHz.

All accesses, either read or write, are preceded by a command instruction to the device. The address field is six bits for a 64-register EEPROM or eight bits for a 256-register EEPROM. The end of the address field is indicated by a dummy 0 bit from the EEPROM, which indicates the entire address field has been transferred to the device. An EEPROM read instruction waveform is shown in [Figure 5-2](#).

Figure 5-2. 64-Word EEPROM Read Instruction Waveform

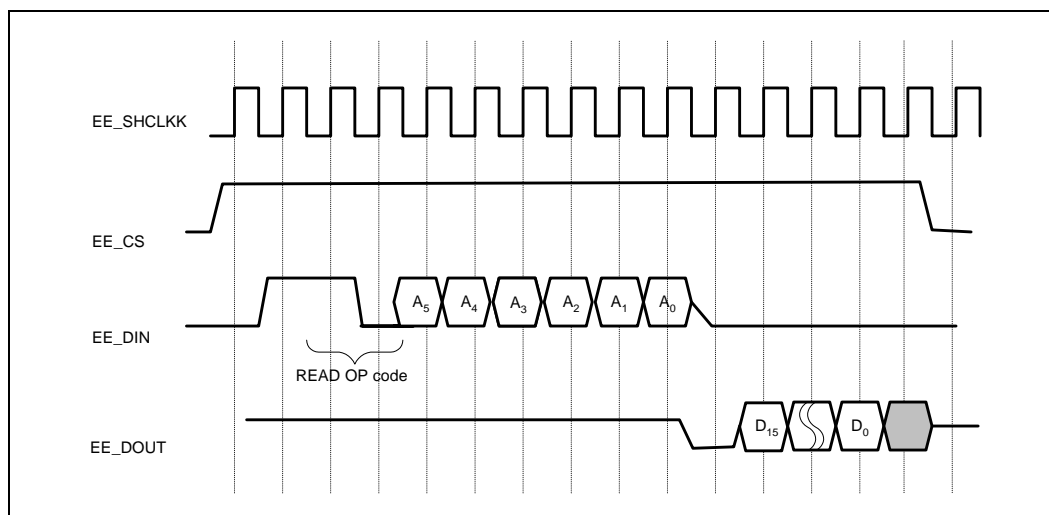

The LAN controller performs an automatic read of seven words (0h, 1h, 2h, Ah, Bh, Ch, and Dh) of the EEPROM after the de-assertion of Reset.

5.3.3 CSMA/CD Unit

The ICH6 integrated LAN controller CSMA/CD unit implements both the IEEE 802.3 Ethernet 10 Mbps and IEEE 802.3u Fast Ethernet 100 Mbps standards. It performs all the CSMA/CD protocol functions (e.g., transmission, reception, collision handling, etc.). The LAN controller CSMA/CD unit interfaces to the 82562ET/EM/EZ/EX 10/100 Mbps Ethernet through the ICH6's LAN Connect interface signals.

5.3.3.1 Full Duplex

When operating in full-duplex mode, the LAN controller can transmit and receive frames simultaneously. Transmission starts regardless of the state of the internal receive path. Reception starts when the platform LAN Connect component detects a valid frame on its receive differential pair. The ICH6 integrated LAN controller also supports the IEEE 802.3x flow control standard, when in full-duplex mode.

The LAN controller operates in either half-duplex mode or full-duplex mode. For proper operation, both the LAN controller CSMA/CD module and the discrete platform LAN Connect component must be set to the same duplex mode. The CSMA duplex mode is set by the LAN Controller Configure command or forced by automatically tracking the mode in the platform LAN Connect component. Following reset, the CSMA defaults to automatically track the platform LAN Connect component duplex mode.

The selection of duplex operation (full or half) and flow control is done in two levels: MAC and LAN Connect.

5.3.3.2 Flow Control

The LAN controller supports IEEE 802.3x frame-based flow control frames only in both full duplex and half duplex switched environments. The LAN controller flow control feature is not intended to be used in shared media environments.

Flow control is optional in full-duplex mode and is selected through software configuration. There are three modes of flow control that can be selected: frame-based transmit flow control, frame-based receive flow control, and none.

5.3.3.3 VLAN Support

The LAN controller supports the IEEE 802.1 standard VLAN. All VLAN flows will be implemented by software. The LAN controller supports the reception of long frames, specifically frames longer than 1518 bytes, including the CRC, if software sets the Long Receive OK bit in the Configuration command. Otherwise, “long” frames are discarded.

5.3.4 Media Management Interface

The management interface allows the processor to control the platform LAN Connect component via a control register in the ICH6 integrated LAN controller. This allows the software driver to place the platform LAN Connect in specific modes (e.g., full duplex, loopback, power down, etc.) without the need for specific hardware pins to select the desired mode. This structure allows the LAN controller to query the platform LAN Connect component for status of the link. This register is the MDI Control Register and resides at offset 10h in the LAN controller CSR. The MDI registers reside within the platform LAN Connect component, and are described in detail in the platform LAN Connect component’s datasheet. The processor writes commands to this register and the LAN controller reads or writes the control/status parameters to the platform LAN Connect component through the MDI register.

5.3.5 TCO Functionality

The ICH6 integrated LAN controller supports management communication to reduce Total Cost of Ownership (TCO). The SMBus is used as an interface between the ASF controller and the integrated TCO host controller. There are two different types of TCO operation that are supported (only one supported at a time), they are 1) Integrated ASF Control or 2) external TCO controller support. The SMLink is a dedicated bus between the LAN controller and the integrated ASF controller (if enabled) or an external management controller. An EEPROM of 256 words is required to support the heartbeat command.

5.3.5.1 Advanced TCO Mode

The Advanced TCO functionalities through the SMLink are listed in [Table 5-3](#).

Table 5-3. Advanced TCO Functionality

Power State	TCO Controller Functionality
D0 nominal	Transmit Set Receive TCO Packets Receive TCO Packets Read ICH6 status (PM & Link state) Force TCO Mode
Dx (x>0)	D0 functionality plus: Read PHY registers
Force TCO Mode	Dx functionality plus: Configuration commands Read/Write PHY registers

Note: For a complete description on various commands, see the *Total Cost of Ownership (TCO) System Management Bus Interface Application Note (AP-430)*.

Transmit Command during Normal Operation

To serve a transmit request from the TCO controller, the ICH6 LAN controller first completes the current transmit DMA, sets the TCO request bit in the PMDR register (see [Section 8.2](#)), and then responds to the TCO controller's transmit request. Following the completion of the TCO transmit DMA, the LAN controller increments the Transmit TCO statistic counter (described in [Section 8.2.14](#)). Following the completion of the transmit operation, the ICH6 increments the nominal transmit statistic counters, clears the TCO request bit in the PMDR register, and resumes its normal transmit flow. The receive flow is not affected during this entire period of time.

Receive TCO

The ICH6 LAN controller supports receive flow towards the TCO controller. The ICH6 can transfer only TCO packets, or all packets that passed MAC address filtering according to its configuration and mode of operation as detailed below. While configured to transfer only TCO packets, it supports Ethernet type II packets with optional VLAN tagging.

Force TCO Mode: While the ICH6 is in the force TCO mode, it may receive packets (TCO or all) directly from the TCO controller. Receiving TCO packets and filtering level is controlled by the set Receive enable command from the TCO controller. Following a reception of a TCO packet, the ICH6 increments its nominal Receive statistic counters as well as the Receive TCO counter.

Dx>0 Power State: While the ICH6 is in a powerdown state, it may receive TCO packets or all directly to the TCO controller. Receiving TCO packets is enabled by the set Receive enable command from the TCO controller. Although TCO packet might match one of the other wake up filters, once it is transferred to the TCO controller, no further matching is searched for and PME is not issued. While receive to TCO is not enabled, a TCO packet may cause a PME if configured to do so (setting TCO to 1 in the filter type).

D0 Power State: At D0 power state, the ICH6 may transfer TCO packets to the TCO controller. At this state, TCO packets are posted first to the host memory, then read by the ICH6, and then posted back to the TCO controller. After the packet is posted to TCO, the receive memory structure (that is occupied by the TCO packet) is reclaimed. Other than providing the necessary receive resources, there is no required device driver intervention with this process. Eventually, the ICH6 increments the receive TCO static counter, clears the TCO request bit, and resumes normal control.

Read ICH6 Status (PM and Link State)

The TCO controller is capable of reading the ICH6 power state and link status. Following a status change, the ICH6 asserts LINKALERT# and then the TCO can read its new power state.

Set Force TCO Mode

The TCO controller put the ICH6 into the Force TCO mode. The ICH6 is set back to the nominal operation following a PCIRST#. Following the transition from nominal mode to a TCO mode, the ICH6 aborts transmission and reception and loses its memory structures. The TCO may configure the ICH6 before it starts transmission and reception if required.

Warning: The Force TCO is a destructive command. It causes the ICH6 to lose its memory structures, and during the Force TCO mode the ICH6 ignores any PCI accesses. Therefore, it is highly recommended to use this command by the TCO controller at system emergency only.

5.4 Alert Standard Format (ASF)

The ASF controller collects information from various components in the system (including the processor, chipset, BIOS, and sensors on the motherboard) and sends this information via the LAN controller to a remote server running a management console. The controller also accepts commands back from the management console and drives the execution of those commands on the local system.

The ASF controller is responsible for monitoring sensor devices and sending packets through the LAN controller SMBus (System Management Bus) interface. These ASF controller alerting capabilities include system health information (such as BIOS messages, POST alerts, operating system failure notifications, and heartbeat signals) to indicate the system is accessible to the server. Also included are environmental notification (e.g., thermal, voltage and fan alerts) that send proactive warnings that something is wrong with the hardware. The packets are used as Alert (S.O.S.) packets or as “heartbeat” status packets. In addition, asset security is provided by messages (e.g., “cover tamper” and “processor missing”) that notify of potential system break-ins and processor or memory theft.

The ASF controller is also responsible for receiving and responding to RMCP (Remote Management and Control Protocol) packets. RMCP packets are used to perform various system APM commands (e.g., reset, power-up, power-cycle, and power-down). RMCP can also be used to ping the system to ensure that it is on the network and running correctly and for capability reporting. A major advantage of ASF is that it provides these services during the time that software is unable to do so (e.g., during a low-power state, during boot-up, or during an operating system hang) but are not precluded from running in the working state.

The ASF controller communicates to the system and the LAN controller logic through the SMBus connections. The first SMBus connects to the host SMBus controller (within the ICH6) and any SMBus platform sensors. The SMBus host is accessible by the system software, including software running on the operating system and the BIOS. Note that the host side bus may require isolation if there are non-auxiliary devices that can pull down the bus when un-powered. The second SMBus connects to the LAN controller. This second SMBus is used to provide a transmit/receive network interface.

The stimulus for causing the ASF controller to send packets can be either internal or external to the ASF controller. External stimuli are link status changes or polling data from SMBus sensor devices; internal events come from, among others, a set of timers or an event caused by software.

The ASF controller provides three local configuration protocols via the host SMBus. The first one is the SMBus ARP interface that is used to identify the SMBus device and allow dynamic SMBus address assignment. The second protocol is the ASF controller command set that allows software to manage an ASF controller compliant interface for retrieving info, sending alerts, and controlling timers.

ICH6 provides an input and an output EEPROM interface. The EEPROM contains the LAN controller configuration and the ASF controller configuration/packet information.

5.4.1 ASF Management Solution Features/Capabilities

- Alerting
 - Transmit SOS packets from S0–S5 states
 - System Health Heartbeats
 - SOS Hardware Events
 - System Boot Failure (Watchdog Expires on boot)
 - LAN Link Loss
 - Entity Presence (on ASF power-up)
 - SMBus Hung
 - Maximum of eight Legacy Sensors
 - Maximum of 128 ASF Sensor events
 - Watchdog Timer for operating system lockup/System Hang/Failure to Boot
 - General Push support for BIOS (POST messages)
- Remote Control
 - Presence Ping Response
 - Configurable Boot Options
 - Capabilities Reporting
 - Auto-ARP Support
 - System Remote Control
 - Power-Down
 - Power-Up
 - Power Cycle
 - System Reset
 - State-Based Security – Conditional Action on WatchDog Expire
- ASF Compliance
 - Compliant with the *Alert Standard Format (ASF) Specification, Version 1.03*
 - PET Compliant Packets
 - RMCP
 - Legacy Sensor Polling
 - ASF Sensor Polling
 - Remote Control Sensor Support
- Advanced Features / Miscellaneous
 - SMBus 2.0 compliant
 - Optional reset extension logic (for use with a power-on reset)

5.4.2 ASF Hardware Support

ASF requires additional hardware to make a complete solution.

Note: If an ASF compatible device is externally connected and properly configured, the internal ICH6 ASF controller will be disabled. The external ASF device will have access to the SMBus controller.

5.4.2.1 82562EM/EX

The 82562EM/EX Ethernet LAN controller is necessary. This LAN controller provides the means of transmitting and receiving data on the network, as well as adding the Ethernet CRC to the data from the ASF.

5.4.2.2 EEPROM (256x16, 1 MHz)

To support the ICH6 ASF solution, a larger, 256x16 1 MHz, EEPROM is necessary to configure defaults on reset and on hard power losses (software un-initiated). The ASF controller shares this EEPROM with the LAN controller and provides a pass through interface to achieve this. The ASF controller expects to have exclusive access to words 40h through F7h. The LAN controller can use the other EEPROM words. The ASF controller will default to safe defaults if the EEPROM is not present or not configured properly (both cause an invalid CRC).

5.4.2.3 Legacy Sensor SMBus Devices

The ASF controller is capable of monitoring up to eight sensor devices on the main SMBus. These sensors are expected to be compliant with the Legacy Sensor Characteristics defined in the *Alert Standard Format (ASF) Specification, Version 1.03*.

5.4.2.4 Remote Control SMBus Devices

The ASF controller is capable of causing remote control actions to Remote Control devices via SMBus. These remote control actions include Power-Up, Power-Down, Power-Cycle, and Reset. The ASF controller supports devices that conform to the *Alert Standard Format (ASF) Specification, Version 1.03*, Remote Control Devices.

5.4.2.5 ASF Sensor SMBus Devices

The ASF controller is capable of monitoring up to 128 ASF sensor devices on the main SMBus. However, ASF is restricted by the number of total events which may reduce the number of SMBus devices supported. The maximum number of events supported by ASF is 128. The ASF sensors are expected to operate as defined in the *Alert Standard Format (ASF) Specification, Version 1.03*.

5.4.3 ASF Software Support

ASF requires software support to make a complete solution. The following software is used as part of the complete solution.

- ASF Configuration driver / application
- Network Driver
- BIOS Support for SMBIOS, SMBus ARP, ACPI
- Sensor Configuration driver / application

Note: Contact your Intel Field Representative for the Client ASF Software Development Kit (SDK) that includes additional documentation and a copy of the client ASF software drivers. Intel also provides an ASF Console SDK to add ASF support to a management console.

5.5 LPC Bridge (w/ System and Management Functions) (D31:F0)

The LPC bridge function of the ICH6 resides in PCI Device 31:Function 0. In addition to the LPC bridge function, D31:F0 contains other functional units including DMA, Interrupt controllers, Timers, Power Management, System Management, GPIO, and RTC. In this chapter, registers and functions associated with other functional units (power management, GPIO, USB, IDE, etc.) are described in their respective sections.

5.5.1 LPC Interface

The ICH6 implements an LPC interface as described in the *Low Pin Count Interface Specification, Revision 1.1*. The LPC interface to the ICH6 is shown in Figure 5-3. Note that the ICH6 implements all of the signals that are shown as optional, but peripherals are not required to do so.

Figure 5-3. LPC Interface Diagram

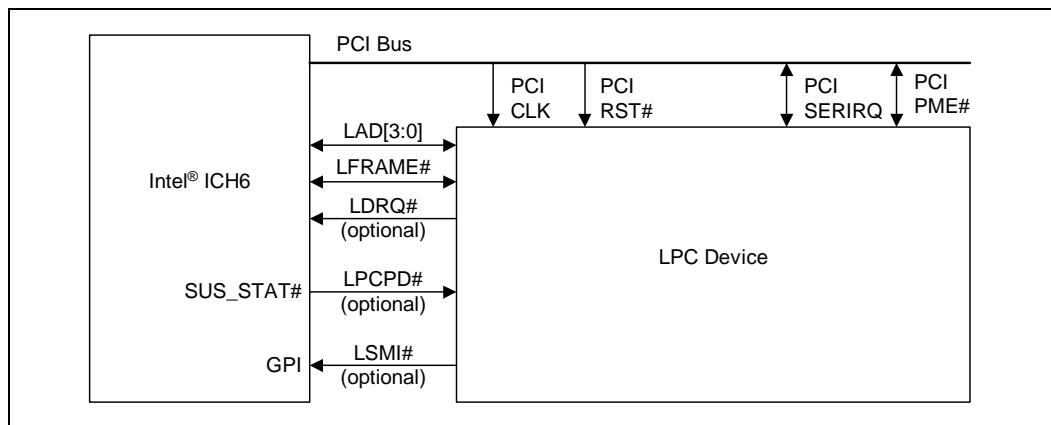

5.5.1.1 LPC Cycle Types

The ICH6 implements all of the cycle types described in the *Low Pin Count Interface Specification, Revision 1.0*. Table 5-4 shows the cycle types supported by the ICH6.

Table 5-4. LPC Cycle Types Supported

Cycle Type	Comment
Memory Read	Single: 1 byte only
Memory Write	Single: 1 byte only
I/O Read	1 byte only. Intel® ICH6 breaks up 16- and 32-bit processor cycles into multiple 8-bit transfers. See Note 1 below.
I/O Write	1 byte only. ICH6 breaks up 16- and 32-bit processor cycles into multiple 8-bit transfers. See Note 1 below.
DMA Read	Can be 1, or 2 bytes
DMA Write	Can be 1, or 2 bytes
Bus Master Read	Can be 1, 2, or 4 bytes. (See Note 2 below)
Bus Master Write	Can be 1, 2, or 4 bytes. (See Note 2 below)

NOTES:

- For memory cycles below 16 MB that do not target enabled firmware hub ranges, the ICH6 performs standard LPC memory cycles. It only attempts 8-bit transfers. If the cycle appears on PCI as a 16-bit transfer, it appears as two consecutive 8-bit transfers on LPC. Likewise, if the cycle appears as a 32-bit transfer on PCI, it appears as four consecutive 8-bit transfers on LPC. If the cycle is not claimed by any peripheral, it is subsequently aborted, and the ICH6 returns a value of all 1s to the processor. This is done to maintain compatibility with ISA memory cycles where pull-up resistors would keep the bus high if no device responds.
- Bus Master Read or Write cycles must be naturally aligned. For example, a 1-byte transfer can be to any address. However, the 2-byte transfer must be word-aligned (i.e., with an address where A0=0). A DWord transfer must be DWord-aligned (i.e., with an address where A1 and A0 are both 0).

5.5.1.2 Start Field Definition

Table 5-5. Start Field Bit Definitions

Bits[3:0] Encoding	Definition
0000	Start of cycle for a generic target
0010	Grant for bus master 0
0011	Grant for bus master 1
1111	Stop/Abort: End of a cycle for a target.

NOTE: All other encodings are RESERVED.

5.5.1.3 Cycle Type / Direction (CYCTYPE + DIR)

The ICH6 always drives bit 0 of this field to 0. Peripherals running bus master cycles must also drive bit 0 to 0. [Table 5-6](#) shows the valid bit encodings.

Table 5-6. Cycle Type Bit Definitions

Bits[3:2]	Bit1	Definition
00	0	I/O Read
00	1	I/O Write
01	0	Memory Read
01	1	Memory Write
10	0	DMA Read
10	1	DMA Write
11	x	Reserved. If a peripheral performing a bus master cycle generates this value, the Intel® ICH6 aborts the cycle.

5.5.1.4 SIZE

Bits[3:2] are reserved. The ICH6 always drives them to 00. Peripherals running bus master cycles are also supposed to drive 00 for bits 3:2; however, the ICH6 ignores those bits. Bits[1:0] are encoded as listed in [Table 5-7](#).

Table 5-7. Transfer Size Bit Definition

Bits[1:0]	Size
00	8-bit transfer (1 byte)
01	16-bit transfer (2 bytes)
10	Reserved. The Intel® ICH6 never drives this combination. If a peripheral running a bus master cycle drives this combination, the ICH6 may abort the transfer.
11	32-bit transfer (4 bytes)

5.5.1.5 SYNC

Valid values for the SYNC field are shown in [Table 5-8](#).

Table 5-8. SYNC Bit Definition

Bits[3:0] ^{1,2}	Indication
0000	Ready: SYNC achieved with no error. For DMA transfers, this also indicates DMA request de-assertion and no more transfers desired for that channel.
0101	Short Wait: Part indicating wait-states. For bus master cycles, the Intel® ICH6 does not use this encoding. Instead, the ICH6 uses the Long Wait encoding (see next encoding below).
0110	Long Wait: Part indicating wait-states, and many wait-states will be added. This encoding driven by the ICH6 for bus master cycles, rather than the Short Wait (0101).
1001	Ready More (Used only by peripheral for DMA cycle): SYNC achieved with no error and more DMA transfers desired to continue after this transfer. This value is valid only on DMA transfers and is not allowed for any other type of cycle.
1010	Error: Sync achieved with error. This is generally used to replace the SERR# or IOCHK# signal on the PCI/ISA bus. It indicates that the data is to be transferred, but there is a serious error in this transfer. For DMA transfers, this not only indicates an error, but also indicates DMA request de-assertion and no more transfers desired for that channel.

NOTES:

1. All other combinations are RESERVED.
2. If the LPC controller receives any SYNC returned from the device other than short (0101), long wait (0110), or ready (0000) when running a FWH cycle, indeterminate results may occur. A FWH device is not allowed to assert an Error SYNC.

5.5.1.6 SYNC Time-Out

There are several error cases that can occur on the LPC interface. The ICH6 responds as defined in section 4.2.1.9 of the *Low Pin Count Interface Specification, Revision 1.1* to the stimuli described therein. There may be other peripheral failure conditions; however, these are not handled by the ICH6.

5.5.1.7 SYNC Error Indication

The ICH6 responds as defined in section 4.2.1.10 of the *Low Pin Count Interface Specification, Revision 1.1*.

Upon recognizing the SYNC field indicating an error, the ICH6 treats this as an SERR by reporting this into the Device 31 Error Reporting Logic.

5.5.1.8 LFRAME# Usage

The ICH6 follows the usage of LFRAME# as defined in the *Low Pin Count Interface Specification, Revision 1.1*.

The ICH6 performs an abort for the following cases (possible failure cases):

- ICH6 starts a Memory, I/O, or DMA cycle, but no device drives a valid SYNC after four consecutive clocks.
- ICH6 starts a Memory, I/O, or DMA cycle, and the peripheral drives an invalid SYNC pattern.
- A peripheral drives an illegal address when performing bus master cycles.
- A peripheral drives an invalid value.

5.5.1.9 I/O Cycles

For I/O cycles targeting registers specified in the ICH6's decode ranges, the ICH6 performs I/O cycles as defined in the *Low Pin Count Interface Specification, Revision 1.1*. These are 8-bit transfers. If the processor attempts a 16-bit or 32-bit transfer, the ICH6 breaks the cycle up into multiple 8-bit transfers to consecutive I/O addresses.

Note: If the cycle is not claimed by any peripheral (and subsequently aborted), the ICH6 returns a value of all 1s (FFh) to the processor. This is to maintain compatibility with ISA I/O cycles where pull-up resistors would keep the bus high if no device responds.

5.5.1.10 Bus Master Cycles

The ICH6 supports Bus Master cycles and requests (using LDRQ#) as defined in the *Low Pin Count Interface Specification, Revision 1.1*. The ICH6 has two LDRQ# inputs, and thus supports two separate bus master devices. It uses the associated START fields for Bus Master 0 (0010b) or Bus Master 1 (0011b).

Note: The ICH6 does not support LPC Bus Masters performing I/O cycles. LPC Bus Masters should only perform memory read or memory write cycles.

5.5.1.11 LPC Power Management

CLKRUN# Protocol (Mobile Only)

The CLKRUN# protocol is same as the PCI specification. Stopping the PCI clock stops the LPC clock.

LPCPD# Protocol

Same timings as for SUS_STAT#. Upon driving SUS_STAT# low, LPC peripherals drive LDRQ# low or tri-state it. ICH6 shuts off the LDRQ# input buffers. After driving SUS_STAT# active, the ICH6 drives LFRAME# low, and tri-states (or drive low) LAD[3:0].

Note: The *Low Pin Count Interface Specification, Revision 1.1* defines the LPCPD# protocol where there is at least 30 μ s from LPCPD# assertion to LRST# assertion. This specification explicitly states that this protocol only applies to entry/exit of low power states which does not include asynchronous reset events. The ICH6 asserts both SUS_STAT# (connects to LPCPD#) and PLTRST# (connects to LRST#) at the same time when the core logic is reset (via CF9h, PWROK, or SYS_RESET#, etc.). This is not inconsistent with the LPC LPCPD# protocol.

5.5.1.12 Configuration and Intel® ICH6 Implications

LPC I/F Decoders

To allow the I/O cycles and memory mapped cycles to go to the LPC interface, the ICH6 includes several decoders. During configuration, the ICH6 must be programmed with the same decode ranges as the peripheral. The decoders are programmed via the Device 31:Function 0 configuration space.

Note: The ICH6 cannot accept PCI write cycles from PCI-to-PCI bridges or devices with similar characteristics (specifically those with a "Retry Read" feature which is enabled) to an LPC device if there is an outstanding LPC read cycle towards the same PCI device or bridge. These cycles are not part of normal system operation, but may be encountered as part of platform validation testing using custom test fixtures.

Bus Master Device Mapping and START Fields

Bus Masters must have a unique START field. In the case of the ICH6 that supports two LPC bus masters, it drives 0010 for the START field for grants to bus master #0 (requested via LDRQ0#) and 0011 for grants to bus master #1 (requested via LDRQ1#.). Thus, no registers are needed to configure the START fields for a particular bus master.

5.6 DMA Operation (D31:F0)

The ICH6 supports LPC DMA using the ICH6's DMA controller. The DMA controller has registers that are fixed in the lower 64 KB of I/O space. The DMA controller is configured using registers in the PCI configuration space. These registers allow configuration of the channels for use by LPC DMA.

The DMA circuitry incorporates the functionality of two 82C37 DMA controllers with seven independently programmable channels (Figure 5-4). DMA controller 1 (DMA-1) corresponds to DMA channels 0–3 and DMA controller 2 (DMA-2) corresponds to channels 5–7. DMA channel 4 is used to cascade the two controllers and defaults to cascade mode in the DMA Channel Mode (DCM) Register. Channel 4 is not available for any other purpose. In addition to accepting requests from DMA slaves, the DMA controller also responds to requests that software initiates. Software may initiate a DMA service request by setting any bit in the DMA Channel Request Register to a 1.

Figure 5-4. Intel® ICH6 DMA Controller

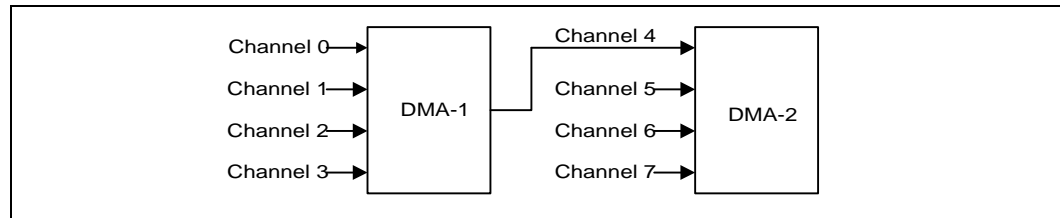

Each DMA channel is hardwired to the compatible settings for DMA device size: channels [3:0] are hardwired to 8-bit, count-by-bytes transfers, and channels [7:5] are hardwired to 16-bit, count-by-words (address shifted) transfers.

ICH6 provides 24-bit addressing in compliance with the ISA-Compatible specification. Each channel includes a 16-bit ISA-Compatible Current Register which holds the 16 least-significant bits of the 24-bit address, an ISA-Compatible Page Register which contains the eight next most significant bits of address.

The DMA controller also features refresh address generation, and autoinitialization following a DMA termination.

5.6.1 Channel Priority

For priority resolution, the DMA consists of two logical channel groups: channels 0–3 and channels 4–7. Each group may be in either fixed or rotate mode, as determined by the DMA Command Register.

DMA I/O slaves normally assert their DREQ line to arbitrate for DMA service. However, a software request for DMA service can be presented through each channel's DMA Request Register. A software request is subject to the same prioritization as any hardware request. See the detailed register description for Request Register programming information in [Section 10.2](#).

5.6.1.1 Fixed Priority

The initial fixed priority structure is as follows:

High priority	Low priority
0, 1, 2, 3	5, 6, 7

The fixed priority ordering is 0, 1, 2, 3, 5, 6, and 7. In this scheme, channel 0 has the highest priority, and channel 7 has the lowest priority. Channels [3:0] of DMA-1 assume the priority position of channel 4 in DMA-2, thus taking priority over channels 5, 6, and 7.

5.6.1.2 Rotating Priority

Rotation allows for "fairness" in priority resolution. The priority chain rotates so that the last channel serviced is assigned the lowest priority in the channel group (0–3, 5–7).

Channels 0–3 rotate as a group of 4. They are always placed between channel 5 and channel 7 in the priority list.

Channel 5–7 rotate as part of a group of 4. That is, channels (5–7) form the first three positions in the rotation, while channel group (0–3) comprises the fourth position in the arbitration.

5.6.2 Address Compatibility Mode

When the DMA is operating, the addresses do not increment or decrement through the High and Low Page Registers. Therefore, if a 24-bit address is 01FFFFh and increments, the next address is 010000h, not 020000h. Similarly, if a 24-bit address is 020000h and decrements, the next address is 02FFFFh, not 01FFFFh. However, when the DMA is operating in 16-bit mode, the addresses still do not increment or decrement through the High and Low Page Registers but the page boundary is now 128 K. Therefore, if a 24-bit address is 01FFFEh and increments, the next address is 000000h, not 0100000h. Similarly, if a 24-bit address is 020000h and decrements, the next address is 03FFFEh, not 02FFFEh. This is compatible with the 82C37 and Page Register implementation used in the PC-AT. This mode is set after CPURST is valid.

5.6.3 Summary of DMA Transfer Sizes

Table 5-9 lists each of the DMA device transfer sizes. The column labeled “Current Byte/Word Count Register” indicates that the register contents represents either the number of bytes to transfer or the number of 16-bit words to transfer. The column labeled “Current Address Increment/Decrement” indicates the number added to or taken from the Current Address register after each DMA transfer cycle. The DMA Channel Mode Register determines if the Current Address Register will be incremented or decremented.

5.6.3.1 Address Shifting When Programmed for 16-Bit I/O Count by Words

Table 5-9. DMA Transfer Size

DMA Device Data Size And Word Count	Current Byte/Word Count Register	Current Address Increment/Decrement
8-Bit I/O, Count By Bytes	Bytes	1
16-Bit I/O, Count By Words (Address Shifted)	Words	1

The ICH6 maintains compatibility with the implementation of the DMA in the PC AT that used the 82C37. The DMA shifts the addresses for transfers to/from a 16-bit device count-by-words.

Note: The least significant bit of the Low Page Register is dropped in 16-bit shifted mode. When programming the Current Address Register (when the DMA channel is in this mode), the Current Address must be programmed to an even address with the address value shifted right by one bit.

The address shifting is shown in Table 5-10.

Table 5-10. Address Shifting in 16-Bit I/O DMA Transfers

Output Address	8-Bit I/O Programmed Address (Ch 0-3)	16-Bit I/O Programmed Address (Ch 5-7) (Shifted)
A0 A[16:1] A[23:17]	A0 A[16:1] A[23:17]	0 A[15:0] A[23:17]

NOTE: The least significant bit of the Page Register is dropped in 16-bit shifted mode.

5.6.4 Autoinitialize

By programming a bit in the DMA Channel Mode Register, a channel may be set up as an autoinitialize channel. When a channel undergoes autoinitialization, the original values of the Current Page, Current Address and Current Byte/Word Count Registers are automatically restored from the Base Page, Address, and Byte/Word Count Registers of that channel following TC. The Base Registers are loaded simultaneously with the Current Registers by the microprocessor when the DMA channel is programmed and remain unchanged throughout the DMA service. The mask bit is not set when the channel is in autoinitialize. Following autoinitialize, the channel is ready to perform another DMA service, without processor intervention, as soon as a valid DREQ is detected.

5.6.5 Software Commands

There are three additional special software commands that the DMA controller can execute. The three software commands are:

- Clear Byte Pointer Flip-Flop
- Master Clear
- Clear Mask Register

They do not depend on any specific bit pattern on the data bus.

5.7 LPC DMA

DMA on LPC is handled through the use of the LDRQ# lines from peripherals and special encodings on LAD[3:0] from the host. Single, Demand, Verify, and Increment modes are supported on the LPC interface. Channels 0–3 are 8 bit channels. Channels 5–7 are 16-bit channels. Channel 4 is reserved as a generic bus master request.

5.7.1 Asserting DMA Requests

Peripherals that need DMA service encode their requested channel number on the LDRQ# signal. To simplify the protocol, each peripheral on the LPC I/F has its own dedicated LDRQ# signal (they may not be shared between two separate peripherals). The ICH6 has two LDRQ# inputs, allowing at least two devices to support DMA or bus mastering.

LDRQ# is synchronous with LCLK (PCI clock). As shown in [Figure 5-5](#), the peripheral uses the following serial encoding sequence:

- Peripheral starts the sequence by asserting LDRQ# low (start bit). LDRQ# is high during idle conditions.
- The next three bits contain the encoded DMA channel number (MSB first).
- The next bit (ACT) indicates whether the request for the indicated DMA channel is active or inactive. The ACT bit is 1 (high) to indicate if it is active and 0 (low) if it is inactive. The case where ACT is low is rare, and is only used to indicate that a previous request for that channel is being abandoned.
- After the active/inactive indication, the LDRQ# signal must go high for at least 1 clock. After that one clock, LDRQ# signal can be brought low to the next encoding sequence.

If another DMA channel also needs to request a transfer, another sequence can be sent on LDRQ#. For example, if an encoded request is sent for channel 2, and then channel 3 needs a transfer before the cycle for channel 2 is run on the interface, the peripheral can send the encoded request for channel 3. This allows multiple DMA agents behind an I/O device to request use of the LPC interface, and the I/O device does not need to self-arbitrate before sending the message.

Figure 5-5. DMA Request Assertion through LDRQ#

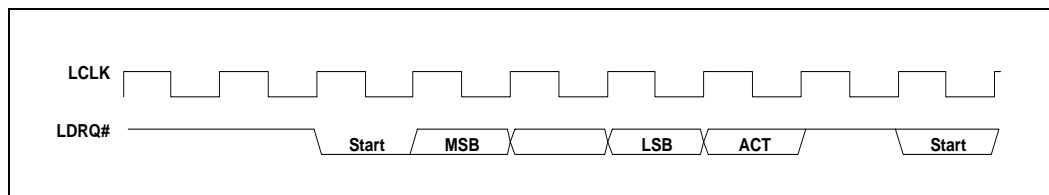

5.7.2 Abandoning DMA Requests

DMA Requests can be de-asserted in two fashions: on error conditions by sending an LDRQ# message with the 'ACT' bit set to 0, or normally through a SYNC field during the DMA transfer. This section describes boundary conditions where the DMA request needs to be removed prior to a data transfer.

There may be some special cases where the peripheral desires to abandon a DMA transfer. The most likely case of this occurring is due to a floppy disk controller which has overrun or underrun its FIFO, or software stopping a device prematurely.

In these cases, the peripheral wishes to stop further DMA activity. It may do so by sending an LDRQ# message with the ACT bit as 0. However, since the DMA request was seen by the ICH6, there is no guarantee that the cycle has not been granted and will shortly run on LPC. Therefore, peripherals must take into account that a DMA cycle may still occur. The peripheral can choose not to respond to this cycle, in which case the host will abort it, or it can choose to complete the cycle normally with any random data.

This method of DMA de-assertion should be prevented whenever possible, to limit boundary conditions both on the ICH6 and the peripheral.

5.7.3 General Flow of DMA Transfers

Arbitration for DMA channels is performed through the 8237 within the host. Once the host has won arbitration on behalf of a DMA channel assigned to LPC, it asserts LFRAME# on the LPC I/F and begins the DMA transfer. The general flow for a basic DMA transfer is as follows:

1. ICH6 starts transfer by asserting 0000b on LAD[3:0] with LFRAME# asserted.
2. ICH6 asserts 'cycle type' of DMA, direction based on DMA transfer direction.
3. ICH6 asserts channel number and, if applicable, terminal count.
4. ICH6 indicates the size of the transfer: 8 or 16 bits.
5. If a DMA read...
 - The ICH6 drives the first 8 bits of data and turns the bus around.
 - The peripheral acknowledges the data with a valid SYNC.
 - If a 16-bit transfer, the process is repeated for the next 8 bits.
6. If a DMA write...
 - The ICH6 turns the bus around and waits for data.
 - The peripheral indicates data ready through SYNC and transfers the first byte.
 - If a 16-bit transfer, the peripheral indicates data ready and transfers the next byte.
7. The peripheral turns around the bus.

5.7.4 Terminal Count

Terminal count is communicated through LAD[3] on the same clock that DMA channel is communicated on LAD[2:0]. This field is the CHANNEL field. Terminal count indicates the last byte of transfer, based upon the size of the transfer.

For example, on an 8-bit transfer size (SIZE field is 00b), if the TC bit is set, then this is the last byte. On a 16-bit transfer (SIZE field is 01b), if the TC bit is set, then the second byte is the last byte. The peripheral, therefore, must internalize the TC bit when the CHANNEL field is communicated, and only signal TC when the last byte of that transfer size has been transferred.

5.7.5 Verify Mode

Verify mode is supported on the LPC interface. A verify transfer to the peripheral is similar to a DMA write, where the peripheral is transferring data to main memory. The indication from the host is the same as a DMA write, so the peripheral will be driving data onto the LPC interface. However, the host will not transfer this data into main memory.

5.7.6 DMA Request De-assertion

An end of transfer is communicated to the ICH6 through a special SYNC field transmitted by the peripheral. An LPC device must not attempt to signal the end of a transfer by de-asserting LDREQ#. If a DMA transfer is several bytes (e.g., a transfer from a demand mode device) the ICH6 needs to know when to de-assert the DMA request based on the data currently being transferred.

The DMA agent uses a SYNC encoding on each byte of data being transferred, which indicates to the ICH6 whether this is the last byte of transfer or if more bytes are requested. To indicate the last byte of transfer, the peripheral uses a SYNC value of 0000b (ready with no error), or 1010b (ready with error). These encodings tell the ICH6 that this is the last piece of data transferred on a DMA read (ICH6 to peripheral), or the byte that follows is the last piece of data transferred on a DMA write (peripheral to ICH6).

When the ICH6 sees one of these two encodings, it ends the DMA transfer after this byte and de-asserts the DMA request to the 8237. Therefore, if the ICH6 indicated a 16-bit transfer, the peripheral can end the transfer after one byte by indicating a SYNC value of 0000b or 1010b. The ICH6 does not attempt to transfer the second byte, and de-asserts the DMA request internally.

If the peripheral indicates a 0000b or 1010b SYNC pattern on the last byte of the indicated size, then the ICH6 only de-asserts the DMA request to the 8237 since it does not need to end the transfer.

If the peripheral wishes to keep the DMA request active, then it uses a SYNC value of 1001b (ready plus more data). This tells the 8237 that more data bytes are requested after the current byte has been transferred, so the ICH6 keeps the DMA request active to the 8237. Therefore, on an 8-bit transfer size, if the peripheral indicates a SYNC value of 1001b to the ICH6, the data will be transferred and the DMA request will remain active to the 8237. At a later time, the ICH6 will then come back with another START-CYCTYPE-CHANNEL-SIZE etc. combination to initiate another transfer to the peripheral.

The peripheral must not assume that the next START indication from the ICH6 is another grant to the peripheral if it had indicated a SYNC value of 1001b. On a single mode DMA device, the 8237 will re-arbitrate after every transfer. Only demand mode DMA devices can be guaranteed that they will receive the next START indication from the ICH6.

Note: Indicating a 0000b or 1010b encoding on the SYNC field of an odd byte of a 16-bit channel (first byte of a 16 bit transfer) is an error condition.

Note: The host stops the transfer on the LPC bus as indicated, fills the upper byte with random data on DMA writes (peripheral to memory), and indicates to the 8237 that the DMA transfer occurred, incrementing the 8237's address and decrementing its byte count.

5.7.7 SYNC Field / LDRQ# Rules

Since DMA transfers on LPC are requested through an LDRQ# assertion message, and are ended through a SYNC field during the DMA transfer, the peripheral must obey the following rule when initiating back-to-back transfers from a DMA channel.

The peripheral must not assert another message for eight LCLKs after a de-assertion is indicated through the SYNC field. This is needed to allow the 8237, that typically runs off a much slower internal clock, to see a message de-asserted before it is re-asserted so that it can arbitrate to the next agent.

Under default operation, the host only performs 8-bit transfers on 8-bit channels and 16-bit transfers on 16-bit channels.

The method by which this communication between host and peripheral through system BIOS is performed is beyond the scope of this specification. Since the LPC host and LPC peripheral are motherboard devices, no "plug-n-play" registry is required.

The peripheral must not assume that the host is able to perform transfer sizes that are larger than the size allowed for the DMA channel, and be willing to accept a SIZE field that is smaller than what it may currently have buffered.

To that end, it is recommended that future devices that may appear on the LPC bus, that require higher bandwidth than 8-bit or 16-bit DMA allow, do so with a bus mastering interface and not rely on the 8237.

5.8 8254 Timers (D31:F0)

The ICH6 contains three counters that have fixed uses. All registers and functions associated with the 8254 timers are in the core well. The 8254 unit is clocked by a 14.31818 MHz clock.

Counter 0, System Timer

This counter functions as the system timer by controlling the state of IRQ0 and is typically programmed for Mode 3 operation. The counter produces a square wave with a period equal to the product of the counter period (838 ns) and the initial count value. The counter loads the initial count value 1 counter period after software writes the count value to the counter I/O address. The counter initially asserts IRQ0 and decrements the count value by two each counter period. The counter negates IRQ0 when the count value reaches 0. It then reloads the initial count value and again decrements the initial count value by two each counter period. The counter then asserts IRQ0 when the count value reaches 0, reloads the initial count value, and repeats the cycle, alternately asserting and negating IRQ0.

Counter 1, Refresh Request Signal

This counter provides the refresh request signal and is typically programmed for Mode 2 operation and only impacts the period of the REF_TOGGLE bit in Port 61. The initial count value is loaded one counter period after being written to the counter I/O address. The REF_TOGGLE bit will have a square wave behavior (alternate between 0 and 1) and will toggle at a rate based on the value in the counter. Programming the counter to anything other than Mode 2 will result in undefined behavior for the REF_TOGGLE bit.

Counter 2, Speaker Tone

This counter provides the speaker tone and is typically programmed for Mode 3 operation. The counter provides a speaker frequency equal to the counter clock frequency (1.193 MHz) divided by the initial count value. The speaker must be enabled by a write to port 061h (see NMI Status and Control ports).

5.8.1 Timer Programming

The counter/timers are programmed as follows:

1. Write a control word to select a counter.
2. Write an initial count for that counter.
3. Load the least and/or most significant bytes (as required by Control Word bits 5, 4) of the 16-bit counter.
4. Repeat with other counters.

Only two conventions need to be observed when programming the counters. First, for each counter, the control word must be written before the initial count is written. Second, the initial count must follow the count format specified in the control word (least significant byte only, most significant byte only, or least significant byte and then most significant byte).

A new initial count may be written to a counter at any time without affecting the counter's programmed mode. Counting is affected as described in the mode definitions. The new count must follow the programmed count format.

If a counter is programmed to read/write two-byte counts, the following precaution applies: A program must not transfer control between writing the first and second byte to another routine which also writes into that same counter. Otherwise, the counter will be loaded with an incorrect count.

The Control Word Register at port 43h controls the operation of all three counters. Several commands are available:

- **Control Word Command.** Specifies which counter to read or write, the operating mode, and the count format (binary or BCD).
- **Counter Latch Command.** Latches the current count so that it can be read by the system. The countdown process continues.
- **Read Back Command.** Reads the count value, programmed mode, the current state of the OUT pins, and the state of the Null Count Flag of the selected counter.

Table 5-11 lists the six operating modes for the interval counters.

Table 5-11. Counter Operating Modes

Mode	Function	Description
0	Out signal on end of count (=0)	Output is 0. When count goes to 0, output goes to 1 and stays at 1 until counter is reprogrammed.
1	Hardware retriggerable one-shot	Output is 0. When count goes to 0, output goes to 1 for one clock time.
2	Rate generator (divide by n counter)	Output is 1. Output goes to 0 for one clock time, then back to 1 and counter is reloaded.
3	Square wave output	Output is 1. Output goes to 0 when counter rolls over, and counter is reloaded. Output goes to 1 when counter rolls over, and counter is reloaded, etc.
4	Software triggered strobe	Output is 1. Output goes to 0 when count expires for one clock time.
5	Hardware triggered strobe	Output is 1. Output goes to 0 when count expires for one clock time.

5.8.2 Reading from the Interval Timer

It is often desirable to read the value of a counter without disturbing the count in progress. There are three methods for reading the counters: a simple read operation, counter Latch command, and the Read-Back command. Each is explained below.

With the simple read and counter latch command methods, the count must be read according to the programmed format; specifically, if the counter is programmed for two byte counts, two bytes must be read. The two bytes do not have to be read one right after the other. Read, write, or programming operations for other counters may be inserted between them.

5.8.2.1 Simple Read

The first method is to perform a simple read operation. The counter is selected through port 40h (counter 0), 41h (counter 1), or 42h (counter 2).

Note: Performing a direct read from the counter does not return a determinate value, because the counting process is asynchronous to read operations. However, in the case of counter 2, the count can be stopped by writing to the GATE bit in port 61h.

5.8.2.2 Counter Latch Command

The Counter Latch command, written to port 43h, latches the count of a specific counter at the time the command is received. This command is used to ensure that the count read from the counter is accurate, particularly when reading a two-byte count. The count value is then read from each counter's Count register as was programmed by the Control register.

The count is held in the latch until it is read or the counter is reprogrammed. The count is then unlatched. This allows reading the contents of the counters on the fly without affecting counting in progress. Multiple Counter Latch Commands may be used to latch more than one counter. Counter Latch commands do not affect the programmed mode of the counter in any way.

If a Counter is latched and then, some time later, latched again before the count is read, the second Counter Latch command is ignored. The count read is the count at the time the first Counter Latch command was issued.

5.8.2.3 Read Back Command

The Read Back command, written to port 43h, latches the count value, programmed mode, and current states of the OUT pin and Null Count flag of the selected counter or counters. The value of the counter and its status may then be read by I/O access to the counter address.

The Read Back command may be used to latch multiple counter outputs at one time. This single command is functionally equivalent to several counter latch commands, one for each counter latched. Each counter's latched count is held until it is read or reprogrammed. Once read, a counter is unlatched. The other counters remain latched until they are read. If multiple count Read Back commands are issued to the same counter without reading the count, all but the first are ignored.

The Read Back command may additionally be used to latch status information of selected counters. The status of a counter is accessed by a read from that counter's I/O port address. If multiple counter status latch operations are performed without reading the status, all but the first are ignored.

Both count and status of the selected counters may be latched simultaneously. This is functionally the same as issuing two consecutive, separate Read Back commands. If multiple count and/or status Read Back commands are issued to the same counters without any intervening reads, all but the first are ignored.

If both count and status of a counter are latched, the first read operation from that counter returns the latched status, regardless of which was latched first. The next one or two reads, depending on whether the counter is programmed for one or two type counts, returns the latched count. Subsequent reads return unlatched count.

5.9 8259 Interrupt Controllers (PIC) (D31:F0)

The ICH6 incorporates the functionality of two 8259 interrupt controllers that provide system interrupts for the ISA compatible interrupts. These interrupts are: system timer, keyboard controller, serial ports, parallel ports, floppy disk, IDE, mouse, and DMA channels. In addition, this interrupt controller can support the PCI based interrupts, by mapping the PCI interrupt onto the compatible ISA interrupt line. Each 8259 core supports eight interrupts, numbered 0–7. [Table 5-12](#) shows how the cores are connected.

Table 5-12. Interrupt Controller Core Connections

8259	8259 Input	Typical Interrupt Source	Connected Pin / Function
Master	0	Internal	Internal Timer / Counter 0 output / HPET #0
	1	Keyboard	IRQ1 via SERIRQ
	2	Internal	Slave controller INTR output
	3	Serial Port A	IRQ3 via SERIRQ, PIRQ#
	4	Serial Port B	IRQ4 via SERIRQ, PIRQ#
	5	Parallel Port / Generic	IRQ5 via SERIRQ, PIRQ#
	6	Floppy Disk	IRQ6 via SERIRQ, PIRQ#
	7	Parallel Port / Generic	IRQ7 via SERIRQ, PIRQ#
Slave	0	Internal Real Time Clock	Internal RTC / HPET #1
	1	Generic	IRQ9 via SERIRQ, SCI, TCO, or PIRQ#
	2	Generic	IRQ10 via SERIRQ, SCI, TCO, or PIRQ#
	3	Generic	IRQ11 via SERIRQ, SCI, TCO, or PIRQ#
	4	PS/2 Mouse	IRQ12 via SERIRQ, SCI, TCO, or PIRQ#
	5	Internal	State Machine output based on processor FERR# assertion. May optionally be used for SCI or TCO interrupt if FERR# not needed.
	6	IDE cable, SATA	IDEIRQ (legacy mode, non-combined or combined mapped as primary), SATA Primary (legacy mode), or via SERIRQ or PIRQ#
	7	IDE cable, SATA	IDEIRQ (legacy mode — combined, mapped as secondary), SATA Secondary (legacy mode) or via SERIRQ or PIRQ#

The ICH6 cascades the slave controller onto the master controller through master controller interrupt input 2. This means there are only 15 possible interrupts for the ICH6 PIC.

Interrupts can individually be programmed to be edge or level, except for IRQ0, IRQ2, IRQ8#, and IRQ13.

Note: Active-low interrupt sources (e.g., the PIRQ#s) are inverted inside the ICH6. In the following descriptions of the 8259s, the interrupt levels are in reference to the signals at the internal interface of the 8259s, after the required inversions have occurred. Therefore, the term “high” indicates “active,” which means “low” on an originating PIRQ#.

5.9.1 Interrupt Handling

5.9.1.1 Generating Interrupts

The PIC interrupt sequence involves three bits, from the IRR, ISR, and IMR, for each interrupt level. These bits are used to determine the interrupt vector returned, and status of any other pending interrupts. Table 5-13 defines the IRR, ISR, and IMR.

Table 5-13. Interrupt Status Registers

Bit	Description
IRR	Interrupt Request Register. This bit is set on a low to high transition of the interrupt line in edge mode, and by an active high level in level mode. This bit is set whether or not the interrupt is masked. However, a masked interrupt will not generate INTR.
ISR	Interrupt Service Register. This bit is set, and the corresponding IRR bit cleared, when an interrupt acknowledge cycle is seen, and the vector returned is for that interrupt.
IMR	Interrupt Mask Register. This bit determines whether an interrupt is masked. Masked interrupts will not generate INTR.

5.9.1.2 Acknowledging Interrupts

The processor generates an interrupt acknowledge cycle that is translated by the host bridge into a PCI Interrupt Acknowledge Cycle to the ICH6. The PIC translates this command into two internal INTA# pulses expected by the 8259 cores. The PIC uses the first internal INTA# pulse to freeze the state of the interrupts for priority resolution. On the second INTA# pulse, the master or slave sends the interrupt vector to the processor with the acknowledged interrupt code. This code is based upon bits [7:3] of the corresponding ICW2 register, combined with three bits representing the interrupt within that controller.

Table 5-14. Content of Interrupt Vector Byte

Master, Slave Interrupt	Bits [7:3]	Bits [2:0]
IRQ7,15	ICW2[7:3]	111
IRQ6,14		110
IRQ5,13		101
IRQ4,12		100
IRQ3,11		011
IRQ2,10		010
IRQ1,9		001
IRQ0,8		000

5.9.1.3 Hardware/Software Interrupt Sequence

1. One or more of the Interrupt Request lines (IRQ) are raised high in edge mode, or seen high in level mode, setting the corresponding IRR bit.
2. The PIC sends INTR active to the processor if an asserted interrupt is not masked.
3. The processor acknowledges the INTR and responds with an interrupt acknowledge cycle. The cycle is translated into a PCI interrupt acknowledge cycle by the host bridge. This command is broadcast over PCI by the ICH6.
4. Upon observing its own interrupt acknowledge cycle on PCI, the ICH6 converts it into the two cycles that the internal 8259 pair can respond to. Each cycle appears as an interrupt acknowledge pulse on the internal INTA# pin of the cascaded interrupt controllers.
5. Upon receiving the first internally generated INTA# pulse, the highest priority ISR bit is set and the corresponding IRR bit is reset. On the trailing edge of the first pulse, a slave identification code is broadcast by the master to the slave on a private, internal three bit wide bus. The slave controller uses these bits to determine if it must respond with an interrupt vector during the second INTA# pulse.
6. Upon receiving the second internally generated INTA# pulse, the PIC returns the interrupt vector. If no interrupt request is present because the request was too short in duration, the PIC returns vector 7 from the master controller.
7. This completes the interrupt cycle. In AEOI mode the ISR bit is reset at the end of the second INTA# pulse. Otherwise, the ISR bit remains set until an appropriate EOI command is issued at the end of the interrupt subroutine.

5.9.2 Initialization Command Words (ICWx)

Before operation can begin, each 8259 must be initialized. In the ICH6, this is a four byte sequence. The four initialization command words are referred to by their acronyms: ICW1, ICW2, ICW3, and ICW4.

The base address for each 8259 initialization command word is a fixed location in the I/O memory space: 20h for the master controller, and A0h for the slave controller.

5.9.2.1 ICW1

An I/O write to the master or slave controller base address with data bit 4 equal to 1 is interpreted as a write to ICW1. Upon sensing this write, the ICH6 PIC expects three more byte writes to 21h for the master controller, or A1h for the slave controller, to complete the ICW sequence.

A write to ICW1 starts the initialization sequence during which the following automatically occur:

1. Following initialization, an interrupt request (IRQ) input must make a low-to-high transition to generate an interrupt.
2. The Interrupt Mask Register is cleared.
3. IRQ7 input is assigned priority 7.
4. The slave mode address is set to 7.
5. Special mask mode is cleared and Status Read is set to IRR.

5.9.2.2 ICW2

The second write in the sequence (ICW2) is programmed to provide bits [7:3] of the interrupt vector that will be released during an interrupt acknowledge. A different base is selected for each interrupt controller.

5.9.2.3 ICW3

The third write in the sequence (ICW3) has a different meaning for each controller.

- For the master controller, ICW3 is used to indicate which IRQ input line is used to cascade the slave controller. Within the ICH6, IRQ2 is used. Therefore, bit 2 of ICW3 on the master controller is set to a 1, and the other bits are set to 0s.
- For the slave controller, ICW3 is the slave identification code used during an interrupt acknowledge cycle. On interrupt acknowledge cycles, the master controller broadcasts a code to the slave controller if the cascaded interrupt won arbitration on the master controller. The slave controller compares this identification code to the value stored in its ICW3, and if it matches, the slave controller assumes responsibility for broadcasting the interrupt vector.

5.9.2.4 ICW4

The final write in the sequence (ICW4) must be programmed for both controllers. At the very least, bit 0 must be set to a 1 to indicate that the controllers are operating in an Intel Architecture-based system.

5.9.3 Operation Command Words (OCW)

These command words reprogram the Interrupt controller to operate in various interrupt modes.

- OCW1 masks and unmask interrupt lines.
- OCW2 controls the rotation of interrupt priorities when in rotating priority mode, and controls the EOI function.
- OCW3 sets up ISR/IRR reads, enables/disables the special mask mode (SMM), and enables/disables polled interrupt mode.

5.9.4 Modes of Operation

5.9.4.1 Fully Nested Mode

In this mode, interrupt requests are ordered in priority from 0 through 7, with 0 being the highest. When an interrupt is acknowledged, the highest priority request is determined and its vector placed on the bus. Additionally, the ISR for the interrupt is set. This ISR bit remains set until: the processor issues an EOI command immediately before returning from the service routine; or if in AEOI mode, on the trailing edge of the second INTA#. While the ISR bit is set, all further interrupts of the same or lower priority are inhibited, while higher levels generate another interrupt. Interrupt priorities can be changed in the rotating priority mode.

5.9.4.2 Special Fully-Nested Mode

This mode is used in the case of a system where cascading is used, and the priority has to be conserved within each slave. In this case, the special fully-nested mode is programmed to the master controller. This mode is similar to the fully-nested mode with the following exceptions:

- When an interrupt request from a certain slave is in service, this slave is not locked out from the master's priority logic and further interrupt requests from higher priority interrupts within the slave are recognized by the master and initiate interrupts to the processor. In the normal-nested mode, a slave is masked out when its request is in service.
- When exiting the Interrupt Service routine, software has to check whether the interrupt serviced was the only one from that slave. This is done by sending a Non-Specific EOI command to the slave and then reading its ISR. If it is 0, a non-specific EOI can also be sent to the master.

5.9.4.3 Automatic Rotation Mode (Equal Priority Devices)

In some applications, there are a number of interrupting devices of equal priority. Automatic rotation mode provides for a sequential 8-way rotation. In this mode, a device receives the lowest priority after being serviced. In the worst case, a device requesting an interrupt has to wait until each of seven other devices are serviced at most once.

There are two ways to accomplish automatic rotation using OCW2; the Rotation on Non-Specific EOI Command (R=1, SL=0, EOI=1) and the rotate in automatic EOI mode which is set by (R=1, SL=0, EOI=0).

5.9.4.4 Specific Rotation Mode (Specific Priority)

Software can change interrupt priorities by programming the bottom priority. For example, if IRQ5 is programmed as the bottom priority device, then IRQ6 is the highest priority device. The Set Priority Command is issued in OCW2 to accomplish this, where: R=1, SL=1, and LO–L2 is the binary priority level code of the bottom priority device.

In this mode, internal status is updated by software control during OCW2. However, it is independent of the EOI command. Priority changes can be executed during an EOI command by using the Rotate on Specific EOI Command in OCW2 (R=1, SL=1, EOI=1 and LO–L2=IRQ level to receive bottom priority).

5.9.4.5 Poll Mode

Poll mode can be used to conserve space in the interrupt vector table. Multiple interrupts that can be serviced by one interrupt service routine do not need separate vectors if the service routine uses the poll command. Poll mode can also be used to expand the number of interrupts. The polling interrupt service routine can call the appropriate service routine, instead of providing the interrupt vectors in the vector table. In this mode, the INTR output is not used and the microprocessor internal Interrupt Enable flip-flop is reset, disabling its interrupt input. Service to devices is achieved by software using a Poll command.

The Poll command is issued by setting P=1 in OCW3. The PIC treats its next I/O read as an interrupt acknowledge, sets the appropriate ISR bit if there is a request, and reads the priority level. Interrupts are frozen from the OCW3 write to the I/O read. The byte returned during the I/O read contains a 1 in bit 7 if there is an interrupt, and the binary code of the highest priority level in bits 2:0.

5.9.4.6 Cascade Mode

The PIC in the ICH6 has one master 8259 and one slave 8259 cascaded onto the master through IRQ2. This configuration can handle up to 15 separate priority levels. The master controls the slaves through a three bit internal bus. In the ICH6, when the master drives 010b on this bus, the slave controller takes responsibility for returning the interrupt vector. An EOI command must be issued twice: once for the master and once for the slave.

5.9.4.7 Edge and Level Triggered Mode

In ISA systems this mode is programmed using bit 3 in ICW1, which sets level or edge for the entire controller. In the ICH6, this bit is disabled and a new register for edge and level triggered mode selection, per interrupt input, is included. This is the Edge/Level control Registers ELCR1 and ELCR2.

If an ELCR bit is 0, an interrupt request will be recognized by a low-to-high transition on the corresponding IRQ input. The IRQ input can remain high without generating another interrupt. If an ELCR bit is 1, an interrupt request will be recognized by a high level on the corresponding IRQ input and there is no need for an edge detection. The interrupt request must be removed before the EOI command is issued to prevent a second interrupt from occurring.

In both the edge and level triggered modes, the IRQ inputs must remain active until after the falling edge of the first internal INTA#. If the IRQ input goes inactive before this time, a default IRQ7 vector is returned.

5.9.4.8 End of Interrupt (EOI) Operations

An EOI can occur in one of two fashions: by a command word write issued to the PIC before returning from a service routine, the EOI command; or automatically when AEOI bit in ICW4 is set to 1.

5.9.4.9 Normal End of Interrupt

In normal EOI, software writes an EOI command before leaving the interrupt service routine to mark the interrupt as completed. There are two forms of EOI commands: Specific and Non-Specific. When a Non-Specific EOI command is issued, the PIC clears the highest ISR bit of those that are set to 1. Non-Specific EOI is the normal mode of operation of the PIC within the ICH6, as the interrupt being serviced currently is the interrupt entered with the interrupt acknowledge. When the PIC is operated in modes that preserve the fully nested structure, software can determine which ISR bit to clear by issuing a Specific EOI. An ISR bit that is masked is not cleared by a Non-Specific EOI if the PIC is in the special mask mode. An EOI command must be issued for both the master and slave controller.

5.9.4.10 Automatic End of Interrupt Mode

In this mode, the PIC automatically performs a Non-Specific EOI operation at the trailing edge of the last interrupt acknowledge pulse. From a system standpoint, this mode should be used only when a nested multi-level interrupt structure is not required within a single PIC. The AEOI mode can only be used in the master controller and not the slave controller.

5.9.5 Masking Interrupts

5.9.5.1 Masking on an Individual Interrupt Request

Each interrupt request can be masked individually by the Interrupt Mask Register (IMR). This register is programmed through OCW1. Each bit in the IMR masks one interrupt channel. Masking IRQ2 on the master controller masks all requests for service from the slave controller.

5.9.5.2 Special Mask Mode

Some applications may require an interrupt service routine to dynamically alter the system priority structure during its execution under software control. For example, the routine may wish to inhibit lower priority requests for a portion of its execution but enable some of them for another portion.

The special mask mode enables all interrupts not masked by a bit set in the Mask register. Normally, when an interrupt service routine acknowledges an interrupt without issuing an EOI to clear the ISR bit, the interrupt controller inhibits all lower priority requests. In the special mask mode, any interrupts may be selectively enabled by loading the Mask Register with the appropriate pattern. The special mask mode is set by OCW3 where: SSMM=1, SMM=1, and cleared where SSMM=1, SMM=0.

5.9.6 Steering PCI Interrupts

The ICH6 can be programmed to allow PIRQA#-PIRQH# to be internally routed to interrupts 3–7, 9–12, 14 or 15. The assignment is programmable through the PIRQx Route Control registers, located at 60–63h and 68–6Bh in Device 31:Function 0. One or more PIRQx# lines can be routed to the same IRQx input. If interrupt steering is not required, the Route registers can be programmed to disable steering.

The PIRQx# lines are defined as active low, level sensitive to allow multiple interrupts on a PCI board to share a single line across the connector. When a PIRQx# is routed to specified IRQ line, software must change the IRQ's corresponding ELCR bit to level sensitive mode. The ICH6 internally inverts the PIRQx# line to send an active high level to the PIC. When a PCI interrupt is routed onto the PIC, the selected IRQ can no longer be used by an active high device (through SERIRQ). However, active low interrupts can share their interrupt with PCI interrupts.

Internal sources of the PIRQs, including SCI and TCO interrupts, cause the external PIRQ to be asserted. The ICH6 receives the PIRQ input, like all of the other external sources, and routes it accordingly.

5.10 Advanced Programmable Interrupt Controller (APIC) (D31:F0)

In addition to the standard ISA-compatible PIC described in the previous chapter, the ICH6 incorporates the APIC. While the standard interrupt controller is intended for use in a uni-processor system, APIC can be used in either a uni-processor or multi-processor system.

5.10.1 Interrupt Handling

The I/O APIC handles interrupts very differently than the 8259. Briefly, these differences are:

- **Method of Interrupt Transmission.** The I/O APIC transmits interrupts through memory writes on the normal datapath to the processor, and interrupts are handled without the need for the processor to run an interrupt acknowledge cycle.
- **Interrupt Priority.** The priority of interrupts in the I/O APIC is independent of the interrupt number. For example, interrupt 10 can be given a higher priority than interrupt 3.
- **More Interrupts.** The I/O APIC in the ICH6 supports a total of 24 interrupts.
- **Multiple Interrupt Controllers.** The I/O APIC architecture allows for multiple I/O APIC devices in the system with their own interrupt vectors.

5.10.2 Interrupt Mapping

The I/O APIC within the ICH6 supports 24 APIC interrupts. Each interrupt has its own unique vector assigned by software. The interrupt vectors are mapped as follows, and match “Config 6” of the Multi-Processor Specification.

Table 5-15. APIC Interrupt Mapping (Sheet 1 of 2)

IRQ #	Via SERIRQ	Direct from Pin	Via PCI Message	Internal Modules
0	No	No	No	Cascade from 8259 #1
1	Yes	No	Yes	
2	No	No	No	8254 Counter 0, HPET #0 (legacy mode)
3	Yes	No	Yes	
4	Yes	No	Yes	
5	Yes	No	Yes	
6	Yes	No	Yes	
7	Yes	No	Yes	
8	No	No	No	RTC, HPET #1 (legacy mode)
9	Yes	No	Yes	Option for SCI, TCO
10	Yes	No	Yes	Option for SCI, TCO
11	Yes	No	Yes	HPET #2, Option for SCI, TCO
12	Yes	No	Yes	
13	No	No	No	FERR# logic
14	Yes	Yes ¹	Yes	IDEIRQ (legacy mode, non-combined or combined mapped as primary), SATA Primary (legacy mode)
15	Yes	Yes	Yes	IDEIRQ (legacy mode — combined, mapped as secondary), SATA Secondary (legacy mode)

Table 5-15. APIC Interrupt Mapping (Sheet 2 of 2)

IRQ #	Via SERIRQ	Direct from Pin	Via PCI Message	Internal Modules
16	PIRQA#	PIRQA#	Yes	Internal devices are routable; see Section 7.1.41 thru Section 7.1.50 .
17	PIRQB#	PIRQB#		
18	PIRQC#	PIRQC#		
19	PIRQD#	PIRQD#		
20	N/A	PIRQE#	Yes	Option for SCI, TCO, HPET #0,1,2. Other internal devices are routable; see Section 7.1.41 thru Section 7.1.50 .
21	N/A	PIRQF#		
22	N/A	PIRQG#		
23	N/A	PIRQH#		

NOTES:

- IDEIRQ can only be driven directly from the pin when in legacy IDE mode.
- When programming the polarity of internal interrupt sources on the APIC, interrupts 0 through 15 receive active-high internal interrupt sources, while interrupts 16 through 23 receive active-low internal interrupt sources.
- If IRQ 11 is used for HPET #2, software should ensure IRQ 11 is not shared with any other devices to guarantee the proper operation of HPET #2. ICH6 hardware does not prevent sharing of IRQ 11.

5.10.3 PCI / PCI Express* Message-Based Interrupts

When external devices through PCI / PCI Express wish to generate an interrupt, they will send the message defined in the *PCI Express* Base Specification, Revision 1.0a* for generating INTA# - INTD#. These will be translated internal assertions/de-assertions of INTA# - INTD#.

5.10.4 Front Side Bus Interrupt Delivery

For processors that support Front Side Bus (FSB) interrupt delivery, the ICH6 requires that the I/O APIC deliver interrupt messages to the processor in a parallel manner, rather than using the I/O APIC serial scheme.

This is done by the ICH6 writing (via DMI) to a memory location that is snooped by the processor(s). The processor(s) snoop the cycle to know which interrupt goes active.

The following sequence is used:

- When the ICH6 detects an interrupt event (active edge for edge-triggered mode or a change for level-triggered mode), it sets or resets the internal IRR bit associated with that interrupt.
- Internally, the ICH6 requests to use the bus in a way that automatically flushes upstream buffers. This can be internally implemented similar to a DMA device request.
- The ICH6 then delivers the message by performing a write cycle to the appropriate address with the appropriate data. The address and data formats are described below in [Section 5.10.4.4](#).

Note: FSB Interrupt Delivery compatibility with processor clock control depends on the processor, not the ICH6.

5.10.4.1 Edge-Triggered Operation

In this case, the “Assert Message” is sent when there is an inactive-to-active edge on the interrupt.

5.10.4.2 Level-Triggered Operation

In this case, the “Assert Message” is sent when there is an inactive-to-active edge on the interrupt. If after the EOI the interrupt is still active, then another “Assert Message” is sent to indicate that the interrupt is still active.

5.10.4.3 Registers Associated with Front Side Bus Interrupt Delivery

Capabilities Indication: The capability to support Front Side Bus interrupt delivery is indicated via ACPI configuration techniques. This involves the BIOS creating a data structure that gets reported to the ACPI configuration software.

5.10.4.4 Interrupt Message Format

The ICH6 writes the message to PCI (and to the Host controller) as a 32-bit memory write cycle. It uses the formats shown in [Table 5-16](#) and [Table 5-17](#) for the address and data.

The local APIC (in the processor) has a delivery mode option to interpret Front Side Bus messages as a SMI in which case the processor treats the incoming interrupt as a SMI instead of as an interrupt. This does not mean that the ICH6 has any way to have a SMI source from ICH6 power management logic cause the I/O APIC to send an SMI message (there is no way to do this). The ICH6’s I/O APIC can only send interrupts due to interrupts which do not include SMI, NMI or INIT. This means that in IA32/IA64 based platforms, Front Side Bus interrupt message format delivery modes 010 (SMI/PMI), 100 (NMI), and 101 (INIT) as indicated in this section, must not be used and is not supported. Only the hardware pin connection is supported by ICH6.

Table 5-16. Interrupt Message Address Format

Bit	Description
31:20	Will always be FEEh
19:12	Destination ID: This is the same as bits 63:56 of the I/O Redirection Table entry for the interrupt associated with this message.
11:4	Extended Destination ID: This is the same as bits 55:48 of the I/O Redirection Table entry for the interrupt associated with this message.
3	Redirection Hint: This bit is used by the processor host bridge to allow the interrupt message to be redirected. 0 = The message will be delivered to the agent (processor) listed in bits 19:12. 1 = The message will be delivered to an agent with a lower interrupt priority This can be derived from bits 10:8 in the Data Field (see below). The Redirection Hint bit will be a 1 if bits 10:8 in the delivery mode field associated with corresponding interrupt are encoded as 001 (Lowest Priority). Otherwise, the Redirection Hint bit will be 0
2	Destination Mode: This bit is used only the Redirection Hint bit is set to 1. If the Redirection Hint bit and the Destination Mode bit are both set to 1, then the logical destination mode is used, and the redirection is limited only to those processors that are part of the logical group as based on the logical ID.
1:0	Will always be 00.

Table 5-17. Interrupt Message Data Format

Bit	Description
31:16	Will always be 0000h.
15	Trigger Mode: 1 = Level, 0 = Edge. Same as the corresponding bit in the I/O Redirection Table for that interrupt.
14	Delivery Status: 1 = Assert, 0 = De-assert. Only Assert messages are sent. This bit is always 1.
13:12	Will always be 00
11	Destination Mode: 1 = Logical, 0 = Physical. Same as the corresponding bit in the I/O Redirection Table for that interrupt.
10:8	Delivery Mode: This is the same as the corresponding bits in the I/O Redirection Table for that interrupt. 000 = Fixed 100 = NMI 001 = Lowest Priority 101 = INIT 010 = SMI/PMI 110 = Reserved 011 = Reserved 111 = ExtINT
7:0	Vector: This is the same as the corresponding bits in the I/O Redirection Table for that interrupt.

5.11 Serial Interrupt (D31:F0)

The ICH6 supports a serial IRQ scheme. This allows a single signal to be used to report interrupt requests. The signal used to transmit this information is shared between the host, the ICH6, and all peripherals that support serial interrupts. The signal line, SERIRQ, is synchronous to PCI clock, and follows the sustained tri-state protocol that is used by all PCI signals. This means that if a device has driven SERIRQ low, it will first drive it high synchronous to PCI clock and release it the following PCI clock. The serial IRQ protocol defines this sustained tri-state signaling in the following fashion:

- **S – Sample Phase.** Signal driven low
- **R – Recovery Phase.** Signal driven high
- **T – Turn-around Phase.** Signal released

The ICH6 supports a message for 21 serial interrupts. These represent the 15 ISA interrupts (IRQ0–1, 2–15), the four PCI interrupts, and the control signals SMI# and IOCHK#. The serial IRQ protocol does not support the additional APIC interrupts (20–23).

Note: When the IDE controller is enabled or the SATA controller is configured for legacy IDE mode, IRQ14 and IRQ15 are expected to behave as ISA legacy interrupts, which cannot be shared, i.e. through the Serial Interrupt pin. If IRQ14/IRQ15 are shared with the Serial Interrupt pin then abnormal system behavior may occur. For example, IRQ14/IRQ15 may not be detected by the ICH6’s interrupt controller.

5.11.1 Start Frame

The serial IRQ protocol has two modes of operation which affect the start frame. These two modes are: Continuous, where the ICH6 is solely responsible for generating the start frame; and Quiet, where a serial IRQ peripheral is responsible for beginning the start frame.

The mode that must first be entered when enabling the serial IRQ protocol is continuous mode. In this mode, the ICH6 asserts the start frame. This start frame is 4, 6, or 8 PCI clocks wide based upon the Serial IRQ Control Register, bits 1:0 at 64h in Device 31:Function 0 configuration space. This is a polling mode.

When the serial IRQ stream enters quiet mode (signaled in the Stop Frame), the SERIRQ line remains inactive and pulled up between the Stop and Start Frame until a peripheral drives the SERIRQ signal low. The ICH6 senses the line low and continues to drive it low for the remainder of the Start Frame. Since the first PCI clock of the start frame was driven by the peripheral in this mode, the ICH6 drives the SERIRQ line low for 1 PCI clock less than in continuous mode. This mode of operation allows for a quiet, and therefore lower power, operation.

5.11.2 Data Frames

Once the Start frame has been initiated, all of the SERIRQ peripherals must start counting frames based on the rising edge of SERIRQ. Each of the IRQ/DATA frames has exactly 3 phases of 1 clock each:

- **Sample Phase.** During this phase, the SERIRQ device drives SERIRQ low if the corresponding interrupt signal is low. If the corresponding interrupt is high, then the SERIRQ devices tri-state the SERIRQ signal. The SERIRQ line remains high due to pull-up resistors (there is no internal pull-up resistor on this signal, an external pull-up resistor is required). A low level during the IRQ0–1 and IRQ2–15 frames indicates that an active-high ISA interrupt is not being requested, but a low level during the PCI INT[A:D], SMI#, and IOCHK# frame indicates that an active-low interrupt is being requested.
- **Recovery Phase.** During this phase, the device drives the SERIRQ line high if in the Sample Phase it was driven low. If it was not driven in the sample phase, it is tri-stated in this phase.
- **Turn-around Phase.** The device tri-states the SERIRQ line

5.11.3 Stop Frame

After all data frames, a Stop Frame is driven by the ICH6. The SERIRQ signal is driven low by the ICH6 for 2 or 3 PCI clocks. The number of clocks is determined by the SERIRQ configuration register. The number of clocks determines the next mode:

Table 5-18. Stop Frame Explanation

Stop Frame Width	Next Mode
2 PCI clocks	Quiet Mode. Any SERIRQ device may initiate a Start Frame
3 PCI clocks	Continuous Mode. Only the host (Intel® ICH6) may initiate a Start Frame

5.11.4 Specific Interrupts Not Supported via SERIRQ

There are three interrupts seen through the serial stream that are not supported by the ICH6. These interrupts are generated internally, and are not sharable with other devices within the system. These interrupts are:

- IRQ0. Heartbeat interrupt generated off of the internal 8254 counter 0.
- IRQ8#. RTC interrupt can only be generated internally.
- IRQ13. Floating point error interrupt generated off of the processor assertion of FERR#.

The ICH6 ignores the state of these interrupts in the serial stream, and does not adjust their level based on the level seen in the serial stream.

5.11.5 Data Frame Format

Table 5-19 shows the format of the data frames. For the PCI interrupts (A–D), the output from the ICH6 is ANDed with the PCI input signal. This way, the interrupt can be signaled via both the PCI interrupt input signal and via the SERIRQ signal (they are shared).

Table 5-19. Data Frame Format

Data Frame #	Interrupt	Clocks Past Start Frame	Comment
1	IRQ0	2	Ignored. IRQ0 can only be generated via the internal 8524
2	IRQ1	5	
3	SMI#	8	Causes SMI# if low. Will set the SERIRQ_SMI_STS bit.
4	IRQ3	11	
5	IRQ4	14	
6	IRQ5	17	
7	IRQ6	20	
8	IRQ7	23	
9	IRQ8	26	Ignored. IRQ8# can only be generated internally.
10	IRQ9	29	
11	IRQ10	32	
12	IRQ11	35	
13	IRQ12	38	
14	IRQ13	41	Ignored. IRQ13 can only be generated from FERR#
15	IRQ14	44	Not attached to PATA or SATA logic
16	IRQ15	47	Not attached to PATA or SATA logic
17	IOCHCK#	50	Same as ISA IOCHCK# going active.
18	PCI INTA#	53	Drive PIRQA#
19	PCI INTB#	56	Drive PIRQB#
20	PCI INTC#	59	Drive PIRQC#
21	PCI INTD#	62	Drive PIRQD#

5.12 Real Time Clock (D31:F0)

The Real Time Clock (RTC) module provides a battery backed-up date and time keeping device with two banks of static RAM with 128 bytes each, although the first bank has 114 bytes for general purpose usage. Three interrupt features are available: time of day alarm with once a second to once a month range, periodic rates of 122 μ s to 500 ms, and end of update cycle notification. Seconds, minutes, hours, days, day of week, month, and year are counted. Daylight savings compensation is available. The hour is represented in twelve or twenty-four hour format, and data can be represented in BCD or binary format. The design is functionally compatible with the Motorola MS146818B. The time keeping comes from a 32.768 kHz oscillating source, which is divided to achieve an update every second. The lower 14 bytes on the lower RAM block has very specific functions. The first ten are for time and date information. The next four (0Ah to 0Dh) are registers, which configure and report RTC functions.

The time and calendar data should match the data mode (BCD or binary) and hour mode (12 or 24 hour) as selected in register B. It is up to the programmer to make sure that data stored in these locations is within the reasonable values ranges and represents a possible date and time. The exception to these ranges is to store a value of C0–FFh in the Alarm bytes to indicate a don't care situation. All Alarm conditions must match to trigger an Alarm Flag, which could trigger an Alarm Interrupt if enabled. The SET bit must be 1 while programming these locations to avoid clashes with an update cycle. Access to time and date information is done through the RAM locations. If a RAM read from the ten time and date bytes is attempted during an update cycle, the value read do not necessarily represent the true contents of those locations. Any RAM writes under the same conditions are ignored.

Note: The leap year determination for adding a 29th day to February does not take into account the end-of-the-century exceptions. The logic simply assumes that all years divisible by 4 are leap years. According to the Royal Observatory Greenwich, years that are divisible by 100 are typically not leap years. In every fourth century (years divisible by 400, like 2000), the 100-year-exception is over-ridden and a leap-year occurs. Note that the year 2100 will be the first time in which the current RTC implementation would incorrectly calculate the leap-year.

The ICH6 does not implement month/year alarms.

5.12.1 Update Cycles

An update cycle occurs once a second, if the SET bit of register B is not asserted and the divide chain is properly configured. During this procedure, the stored time and date are incremented, overflow is checked, a matching alarm condition is checked, and the time and date are rewritten to the RAM locations. The update cycle will start at least 488 μ s after the UIP bit of register A is asserted, and the entire cycle does not take more than 1984 μ s to complete. The time and date RAM locations (0–9) are disconnected from the external bus during this time.

To avoid update and data corruption conditions, external RAM access to these locations can safely occur at two times. When a updated-ended interrupt is detected, almost 999 ms is available to read and write the valid time and date data. If the UIP bit of Register A is detected to be low, there is at least 488 μ s before the update cycle begins.

Warning: The overflow conditions for leap years and daylight savings adjustments are based on more than one date or time item. To ensure proper operation when adjusting the time, the new time and data values should be set at least two seconds before one of these conditions (leap year, daylight savings time adjustments) occurs.

5.12.2 Interrupts

The real-time clock interrupt is internally routed within the ICH6 both to the I/O APIC and the 8259. It is mapped to interrupt vector 8. This interrupt does not leave the ICH6, nor is it shared with any other interrupt. IRQ8# from the SERIRQ stream is ignored. However, the High Performance Event Timers can also be mapped to IRQ8#; in this case, the RTC interrupt is blocked.

5.12.3 Lockable RAM Ranges

The RTC's battery-backed RAM supports two 8-byte ranges that can be locked via the configuration space. If the locking bits are set, the corresponding range in the RAM will not be readable or writable. A write cycle to those locations will have no effect. A read cycle to those locations will not return the location's actual value (resultant value is undefined).

Once a range is locked, the range can be unlocked only by a hard reset, which will invoke the BIOS and allow it to relock the RAM range.

5.12.4 Century Rollover

The ICH6 detects a rollover when the Year byte (RTC I/O space, index offset 09h) transitions from 99 to 00. Upon detecting the rollover, the ICH6 sets the NEWCENTURY_STS bit (TCOBASE + 04h, bit 7). If the system is in an S0 state, this causes an SMI#. The SMI# handler can update registers in the RTC RAM that are associated with century value. If the system is in a sleep state (S1–S5) when the century rollover occurs, the ICH6 also sets the NEWCENTURY_STS bit, but no SMI# is generated. When the system resumes from the sleep state, BIOS should check the NEWCENTURY_STS bit and update the century value in the RTC RAM.

5.12.5 Clearing Battery-Backed RTC RAM

Clearing CMOS RAM in an ICH6-based platform can be done by using a jumper on RTCRST# or GPI. Implementations should not attempt to clear CMOS by using a jumper to pull VccRTC low.

Using RTCRST# to clear CMOS

A jumper on RTCRST# can be used to clear CMOS values, as well as reset to default, the state of those configuration bits that reside in the RTC power well. When the RTCRST# is strapped to ground, the RTC_PWR_STS bit (D31:F0:A4h bit 2) will be set and those configuration bits in the RTC power well will be set to their default state. BIOS can monitor the state of this bit, and manually clear the RTC CMOS array once the system is booted. The normal position would cause RTCRST# to be pulled up through a weak pull-up resistor. [Table 5-20](#) shows which bits are set to their default state when RTCRST# is asserted. This RTCRST# jumper technique allows the jumper to be moved and then replaced—all while the system is powered off. Then, once booted, the RTC_PWR_STS can be detected in the set state.

Table 5-20. Configuration Bits Reset by RTCRST# Assertion

Bit Name	Register	Location	Bit(s)	Default State
Alarm Interrupt Enable (AIE)	Register B (General Configuration) (RTC_REGB)	I/O space (RTC Index + 0Bh)	5	X
Alarm Flag (AF)	Register C (Flag Register) (RTC_REGC)	I/O space (RTC Index + 0Ch)	5	X
SWSMI_RATE_SEL	General PM Configuration 3 Register GEN_PMCON_3	D31:F0:A4h	7:6	0
SLP_S4# Minimum Assertion Width	General PM Configuration 3 Register GEN_PMCON_3	D31:F0:A4h	5:4	0
SLP_S4# Assertion Stretch Enable	General PM Configuration 3 Register GEN_PMCON_3	D31:F0:A4h	3	0
RTC Power Status (RTC_PWR_STS)	General PM Configuration 3 Register GEN_PMCON_3	D31:F0:A4h	2	0
Power Failure (PWR_FLR)	General PM Configuration 3 Register (GEN_PMCON_3)	D31:F0:A4h	1	0
AFTERG3_EN	General PM Configuration 3 Register GEN_PMCON_3	D31:F0:A4h	0	0
Power Button Override Status (PRBTNOR_STS)	Power Management 1 Status Register (PM1_STS)	PMBase + 00h	11	0
RTC Event Enable (RTC_EN)	Power Management 1 Enable Register (PM1_EN)	PMBase + 02h	10	0
Sleep Type (SLP_TYP)	Power Management 1 Control (PM1_CNT)	PMBase + 04h	12:10	0
PME_EN	General Purpose Event 0 Enables Register (GPE0_EN)	PMBase + 2Ch	11	0
BATLOW_EN	General Purpose Event 0 Enables Register (GPE0_EN)	PMBase + 2Ch	10	0
RI_EN	General Purpose Event 0 Enables Register (GPE0_EN)	PMBase + 2Ch	8	0
NEWCENTURY_STS	TCO1 Status Register (TCO1_STS)	TCOBase + 04h	7	0
Intruder Detect (INTRD_DET)	TCO2 Status Register (TCO2_STS)	TCOBase + 06h	0	0
Top Swap (TS)	Backed Up Control Register (BUC)	Chipset Configuration Registers: Offset 3414h	0	X
PATA Reset State (PRS) (Mobile Only)	Backed Up Control Register (BUC)	Chipset Configuration Registers: Offset 3414h	1	1

Using a GPI to Clear CMOS

A jumper on a GPI can also be used to clear CMOS values. BIOS would detect the setting of this GPI on system boot-up, and manually clear the CMOS array.

Note: The GPI strap technique to clear CMOS requires multiple steps to implement. The system is booted with the jumper in new position, then powered back down. The jumper is replaced back to the normal position, then the system is rebooted again.

Warning: Clearing CMOS, using a jumper on VccRTC, must **not** be implemented.

5.13 Processor Interface (D31:F0)

The ICH6 interfaces to the processor with a variety of signals

- Standard Outputs to processor: A20M#, SMI#, NMI, INIT#, INTR, STPCLK#, IGNNE#, CPUSLP#, CPUPWRGD
- Standard Input from processor: FERR#
- Intel SpeedStep® technology output to processor: CPUPWRGOOD (In mobile configurations)

Most ICH6 outputs to the processor use standard buffers. The ICH6 has separate V_CPU_IO signals that are pulled up at the system level to the processor voltage, and thus determines V_{OH} for the outputs to the processor.

5.13.1 Processor Interface Signals

This section describes each of the signals that interface between the ICH6 and the processor(s). Note that the behavior of some signals may vary during processor reset, as the signals are used for frequency strapping.

5.13.1.1 A20M# (Mask A20)

The A20M# signal is active (low) when both of the following conditions are true:

- The ALT_A20_GATE bit (Bit 1 of PORT92 register) is a 0
- The A20GATE input signal is a 0

The A20GATE input signal is expected to be generated by the external microcontroller (KBC).

5.13.1.2 INIT# (Initialization)

The INIT# signal is active (driven low) based on any one of several events described in [Table 5-21](#). When any of these events occur, INIT# is driven low for 16 PCI clocks, then driven high.

Note: The 16-clock counter for INIT# assertion halts while STPCLK# is active. Therefore, if INIT# is supposed to go active while STPCLK# is asserted, it actually goes active after STPCLK# goes inactive.

This section refers to INIT#, but applies to two signals: INIT# and INIT3_3V#, as INIT3_3V# is functionally identical to INIT#, but signaling at 3.3 V.

Table 5-21. INIT# Going Active

Cause of INIT# Going Active	Comment
Shutdown special cycle from processor.	
PORT92 write, where INIT_NOW (bit 0) transitions from a 0 to a 1.	
PORTCF9 write, where SYS_RST (bit 1) was a 0 and RST_CPU (bit 2) transitions from 0 to 1.	
RCIN# input signal goes low. RCIN# is expected to be driven by the external microcontroller (KBC).	0 to 1 transition on RCIN# must occur before the Intel® ICH6 will arm INIT# to be generated again. NOTE: RCIN# signal is expected to be high during S3 _{HOT} and low during S3 _{COLD} , S4, and S5 states. Transition on the RCIN# signal in those states (or the transition to those states) may not necessarily cause the INIT# signal to be generated to the processor.
Processor BIST	To enter BIST, software sets CPU_BIST_EN bit and then does a full processor reset using the CF9 register.

5.13.1.3 FERR#/IGNNE# (Numeric Coprocessor Error / Ignore Numeric Error)

The ICH6 supports the coprocessor error function with the FERR#/IGNNE# pins. The function is enabled via the COPROC_ERR_EN bit (Chipset Configuration Registers: Offset 31FFh: bit 1). FERR# is tied directly to the Coprocessor Error signal of the processor. If FERR# is driven active by the processor, IRQ13 goes active (internally). When it detects a write to the COPROC_ERR register (I/O Register F0h), the ICH6 negates the internal IRQ13 and drives IGNNE# active. IGNNE# remains active until FERR# is driven inactive. IGNNE# is never driven active unless FERR# is active.

Figure 5-6. Coprocessor Error Timing Diagram

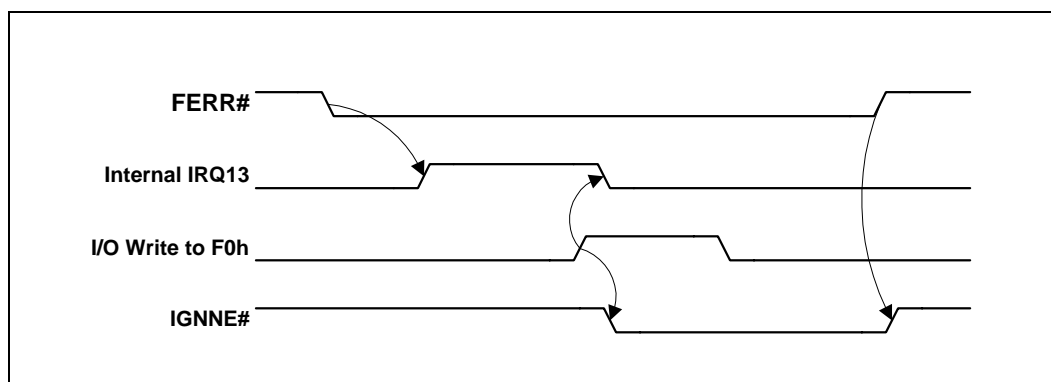

If COPROC_ERR_EN is not set, the assertion of FERR# will not generate an internal IRQ13, nor will the write to F0h generate IGNNE#.

5.13.1.4 NMI (Non-Maskable Interrupt)

Non-Maskable Interrupts (NMIs) can be generated by several sources, as described in [Table 5-22](#).

Table 5-22. NMI Sources

Cause of NMI	Comment
SERR# goes active (either internally, externally via SERR# signal, or via message from (G)MCH)	Can instead be routed to generate an SCI, through the NMI2SCI_EN bit (Device 31:Function 0, TCO Base + 08h, bit 11).
IOCHK# goes active via SERIRQ# stream (ISA system Error)	Can instead be routed to generate an SCI, through the NMI2SCI_EN bit (Device 31:Function 0, TCO Base + 08h, bit 11).

5.13.1.5 Stop Clock Request and Processor Sleep (STPCLK# and CPUSLP#)

The ICH6 power management logic controls these active-low signals. Refer to [Section 5.14](#) for more information on the functionality of these signals.

5.13.1.6 Processor Power Good (CPUPWRGOOD)

This signal is connected to the processor’s PWRGOOD input. In mobile configurations to allow for Intel SpeedStep technology support, this signal is kept high during an Intel SpeedStep technology state transition to prevent loss of processor context. This is an open-drain output signal (external pull-up resistor required) that represents a logical AND of the ICH6’s PWROK and VRMPWRGD signals.

5.13.1.7 Deeper Sleep (DPSLP#) (Mobile Only)

This active-low signal controls the internal gating of the processor’s core clock. This signal asserts before and de-asserts after the STP_CPU# signal to effectively stop the processor’s clock (internally) in the states in which STP_CPU# can be used to stop the processor’s clock externally.

5.13.2 Dual-Processor Issues (Desktop Only)

5.13.2.1 Signal Differences

In dual-processor designs, some of the processor signals are unused or used differently than for uniprocessor designs.

Table 5-23. DP Signal Differences

Signal	Difference
A20M# / A20GATE	Generally not used, but still supported by Intel® ICH6.
STPCLK#	Used for S1 State as well as preparation for entry to S3–S5 Also allows for THERM# based throttling (not via ACPI control methods). Should be connected to both processors.
FERR# / IGNNE#	Generally not used, but still supported by ICH6.

5.13.2.2 Power Management

For multiple-processor (or multiple-core) configurations in which more than one Stop Grant cycle may be generated, the (G)MCH is expected to count Stop Grant cycles and only pass the last one through to the ICH6. This prevents the ICH6 from getting out of sync with the processor on multiple STPCLK# assertions.

Because the S1 state will have the STPCLK# signal active, the STPCLK# signal can be connected to both processors. However, for ACPI implementations, the BIOS must indicate that the ICH6 only supports the C1 state for dual-processor designs.

In going to the S1 state for desktop, multiple Stop-Grant cycles will be generated by the processors. The Intel ICH6 also has the option to assert the processor's SLP# signal (CPUSLP#). It is assumed that prior to setting the SLP_EN bit that causes the transition to the S1 state, the processors will not be executing code that is likely to delay the Stop-Grant cycles.

In going to the S3, S4, or S5 states, the system will appear to pass through the S1 state; thus, STPCLK# and SLP# are also used. During the S3, S4, and S5 states, both processors will lose power. Upon exit from those states, the processors will have their power restored.

5.14 Power Management (D31:F0)

5.14.1 Features

- Support for *Advanced Configuration and Power Interface, Version 2.0 (ACPI)* providing power and thermal management
 - ACPI 24-Bit Timer
 - Software initiated throttling of processor performance for Thermal and Power Reduction
 - Hardware Override to throttle processor performance if system too hot
 - SCI and SMI# Generation
- PCI PME# signal for Wake Up from Low-Power states
- System Clock Control
 - (Mobile Only) ACPI C2 state: Stop Grant (using STPCLK# signal) halts processor's instruction stream
 - (Mobile Only) ACPI C3 State: Ability to halt processor clock (but not memory clock)
 - (Mobile Only) ACPI C4 State: Ability to lower processor voltage.
 - (Mobile Only) CLKRUN# Protocol for PCI Clock Starting/Stopping
- System Sleep State Control
 - ACPI S1 state: Stop Grant (using STPCLK# signal) halts processor's instruction stream (only STPCLK# active, and CPUSLP# optional)
 - ACPI S3 state — Suspend to RAM (STR)
 - ACPI S4 state — Suspend-to-Disk (STD)
 - ACPI G2/S5 state — Soft Off (SOFF)
 - Power Failure Detection and Recovery
- Streamlined Legacy Power Management for APM-Based Systems

5.14.2 Intel[®] ICH6 and System Power States

Table 5-24 shows the power states defined for ICH6-based platforms. The state names generally match the corresponding ACPI states.

Table 5-24. General Power States for Systems Using Intel[®] ICH6

State/ Substates	Legacy Name / Description
G0/S0/C0	Full On: Processor operating. Individual devices may be shut down to save power. The different processor operating levels are defined by Cx states, as shown in Table 5-25. Within the C0 state, the Intel [®] ICH6 can throttle the processor using the STPCLK# signal to reduce power consumption. The throttling can be initiated by software or by the operating system or BIOS.
G0/S0/C1	Auto-Halt: Processor has executed an AutoHalt instruction and is not executing code. The processor snoops the bus and maintains cache coherency.
G0/S0/C2 (Mobile Only)	Stop-Grant: The STPCLK# signal goes active to the processor. The processor performs a Stop-Grant cycle, halts its instruction stream, and remains in that state until the STPCLK# signal goes inactive. In the Stop-Grant state, the processor snoops the bus and maintains cache coherency.
G0/S0/C3 (Mobile Only)	Stop-Clock: The STPCLK# signal goes active to the processor. The processor performs a Stop-Grant cycle, halts its instruction stream. ICH6 then asserts DPUSLP# followed by STP_CPU#, which forces the clock generator to stop the processor clock. This is also used for Intel SpeedStep [®] technology support. Accesses to memory (by graphics, PCI, or internal units) is not permitted while in a C3 state.
G0/S0/C4 (Mobile Only)	Stop-Clock with Lower Processor Voltage: This closely resembles the G0/S0/C3 state. However, after the ICH6 has asserted STP_CPU#, it then lowers the voltage to the processor. This reduces the leakage on the processor. Prior to exiting the C4 state, the ICH6 increases the voltage to the processor.
G1/S1	Stop-Grant: Similar to G0/S0/C2 state. ICH6 also has the option to assert the CPUSLP# signal to further reduce processor power consumption. NOTE: The behavior for this state is slightly different when supporting iA64 processors.
G1/S3	Suspend-To-RAM (STR): The system context is maintained in system DRAM, but power is shut off to non-critical circuits. Memory is retained, and refreshes continue. All clocks stop except RTC clock.
G1/S4	Suspend-To-Disk (STD): The context of the system is maintained on the disk. All power is then shut off to the system except for the logic required to resume.
G2/S5	Soft Off (SOFF): System context is not maintained. All power is shut off except for the logic required to restart. A full boot is required when waking.
G3	Mechanical OFF (MOFF): System context not maintained. All power is shut off except for the RTC. No "Wake" events are possible, because the system does not have any power. This state occurs if the user removes the batteries, turns off a mechanical switch, or if the system power supply is at a level that is insufficient to power the "waking" logic. When system power returns, transition will depend on the state just prior to the entry to G3 and the AFTERG3 bit in the GEN_PMCON3 register (D31:F0, offset A4). Refer to Table 5-32 for more details.

Table 5-25 shows the transitions rules among the various states. Note that transitions among the various states may appear to temporarily transition through intermediate states. For example, in going from S0 to S1, it may appear to pass through the G0/S0/C2 states. These intermediate transitions and states are not listed in the table.

Table 5-25. State Transition Rules for Intel® ICH6

Present State	Transition Trigger	Next State
G0/S0/C0	<ul style="list-style-type: none"> Processor halt instruction Level 2 Read Level 3 Read (Mobile Only) Level 4 Read (Mobile Only) SLP_EN bit set Power Button Override Mechanical Off/Power Failure 	<ul style="list-style-type: none"> G0/S0/C1 G0/S0/C2 G0/S0/C2, G0/S0/C3 or G0/S0/C4 - depending on C4onC3_EN bit (D31:F0:Offset A0h:bit 7) and BM_STS_ZERO_EN bit (D31:F0:Offset A9h:bit 2) (Mobile Only) G1/Sx or G2/S5 state G2/S5 G3
G0/S0/C1	<ul style="list-style-type: none"> Any Enabled Break Event STPCLK# goes active Power Button Override Power Failure 	<ul style="list-style-type: none"> G0/S0/C0 G0/S0/C2 G2/S5 G3
G0/S0/C2 (Mobile Only)	<ul style="list-style-type: none"> Any Enabled Break Event Power Button Override Power Failure Previously in C3/C4 and bus masters idle 	<ul style="list-style-type: none"> G0/S0/C0 G2/S5 G3 C3 or C4 - depending on PDME bit (D31:F0:Offset A9h: bit 4)
G0/S0/C3 (Mobile Only)	<ul style="list-style-type: none"> Any Enabled Break Event Any Bus Master Event Power Button Override Power Failure Previously in C4 and bus masters idle 	<ul style="list-style-type: none"> G0/S0/C0 G0/S0/C2 - if PUME bit (D31:F0: Offset A9h: bit 3) is set, else G0/S0/C0 G2/S5 G3 C4 - depending on PDME bit (D31:F0: Offset A9h: bit 4)
G0/S0/C4 (Mobile Only)	<ul style="list-style-type: none"> Any Enabled Break Event Any Bus Master Event Power Button Override Power Failure 	<ul style="list-style-type: none"> G0/S0/C0 G0/S0/C2 - if PUME bit (D31:F0: Offset A9h: bit 3) is set, else G0/S0/C0 G2/S5 G3
G1/S1, G1/S3, or G1/S4	<ul style="list-style-type: none"> Any Enabled Wake Event Power Button Override Power Failure 	<ul style="list-style-type: none"> G0/S0/C0¹ G2/S5 G3
G2/S5	<ul style="list-style-type: none"> Any Enabled Wake Event Power Failure 	<ul style="list-style-type: none"> G0/S0/C0¹ G3
G3	<ul style="list-style-type: none"> Power Returns 	<ul style="list-style-type: none"> Optional to go to S0/C0 (reboot) or G2/S5 (stay off until power button pressed or other wake event).^{1,2}

NOTES:

- Transitions from the S1–S5 or G3 states to the S0 state are deferred until BATLOW# is inactive in mobile configurations.
- Some wake events can be preserved through power failure.

5.14.3 System Power Planes

The system has several independent power planes, as described in [Table 5-26](#). Note that when a particular power plane is shut off, it should go to a 0 V level.

Table 5-26. System Power Plane

Plane	Controlled By	Description
Processor	SLP_S3# signal	The SLP_S3# signal can be used to cut the power to the processor completely. The DPRSLPVR support allows lowering the processor's voltage during the C4 state. S3 _{HOT} : The new S3 _{HOT} state keeps more of the platform logic, including the ICH6 core well, powered to reduce the cost of external power plane logic. SLP_S3# is only used to remove power to the processor and to shut system clocks. This impacts the board design, but there is no specific ICH6 bit or strap needed to indicate which option is selected.
MAIN	SLP_S3# signal (S3 _{COLD}) or SLP_S4# signal (S3 _{HOT})	S3 _{COLD} : When SLP_S3# goes active, power can be shut off to any circuit not required to wake the system from the S3 state. Since the S3 state requires that the memory context be preserved, power must be retained to the main memory. The processor, devices on the PCI bus, LPC I/F, and graphics will typically be shut off when the Main power plane is shut, although there may be small subsections powered. S3 _{HOT} : SLP_S4# is used to cut the main power well, rather than using SLP_S3#. This impacts the board design, but there is no specific ICH6 bit or strap needed to indicate which option is selected.
MEMORY	SLP_S4# signal SLP_S5# signal	When the SLP_S4# goes active, power can be shut off to any circuit not required to wake the system from the S4. Since the memory context does not need to be preserved in the S4 state, the power to the memory can also be shut down. When SLP_S5# goes active, power can be shut to any circuit not required to wake the system from the S5 state. Since the memory context does not need to be preserved in the S5 state, the power to the memory can also be shut.
DEVICE[n]	GPIO	Individual subsystems may have their own power plane. For example, GPIO signals may be used to control the power to disk drives, audio amplifiers, or the display screen.

5.14.4 SMI#/SCI Generation

On any SMI# event taking place, ICH6 asserts SMI# to the processor, which causes it to enter SMM space. SMI# remains active until the EOS bit is set. When the EOS bit is set, SMI# goes inactive for a minimum of 4 PCICLK. If another SMI event occurs, SMI# is driven active again.

The SCI is a level-mode interrupt that is typically handled by an ACPI-aware operating system. In non-APIC systems (which is the default), the SCI IRQ is routed to one of the 8259 interrupts (IRQ 9, 10, or 11). The 8259 interrupt controller must be programmed to level mode for that interrupt.

In systems using the APIC, the SCI can be routed to interrupts 9, 10, 11, 20, 21, 22, or 23. The interrupt polarity changes depending on whether it is on an interrupt shareable with a PIRQ or not (see [Section 10.1.13](#)). The interrupt remains asserted until all SCI sources are removed.

Table 5-27 shows which events can cause an SMI# and SCI. Note that some events can be programmed to cause either an SMI# or SCI. The usage of the event for SCI (instead of SMI#) is typically associated with an ACPI-based system. Each SMI# or SCI source has a corresponding enable and status bit.

Table 5-27. Causes of SMI# and SCI (Sheet 1 of 2)

Cause ¹⁻⁵	SCI	SMI	Additional Enables	Where Reported
PME#	Yes	Yes	PME_EN=1	PME_STS
PME_B0 (internal EHCI controller)	Yes	Yes	PME_B0_EN=1	PME_B0_STS
PCI Express* PME Messages	Yes	Yes	PCI_EXP_EN=1 (Not enabled for SMI)	PCI_EXP_STS
PCI Express Hot Plug Message	Yes	Yes	HOT_PLUG_EN=1 (Not enabled for SMI)	HOT_PLUG_STS
Power Button Press	Yes	Yes	PWRBTN_EN=1	PWRBTN_STS
Power Button Override (Note 6)	Yes	No	None	PRBTNOR_STS
RTC Alarm	Yes	Yes	RTC_EN=1	RTC_STS
Ring Indicate	Yes	Yes	RI_EN=1	RI_STS
AC '97 wakes	Yes	Yes	AC97_EN=1	AC97_STS
USB#1 wakes	Yes	Yes	USB1_EN=1	USB1_STS
USB#2 wakes	Yes	Yes	USB2_EN=1	USB2_STS
USB#3 wakes	Yes	Yes	USB3_EN=1	USB3_STS
USB#4 wakes	Yes	Yes	USB4_EN=1	USB4_STS
THRM# pin active	Yes	Yes	THRM_EN=1	THRM_STS
ACPI Timer overflow (2.34 sec.)	Yes	Yes	TMROF_EN=1	TMROF_STS
Any GPI ⁷	Yes	Yes	GPI[x]_Route=10 (SCI) GPI[x]_Route=01 (SMI) GPE0[x]_EN=1	GPI[x]_STS GPE0_STS
TCO SCI Logic	Yes	No	TCOSCI_EN=1	TCOSCI_STS
TCO SCI message from (G)MCH	Yes	No	none	MCHSCI_STS
TCO SMI Logic	No	Yes	TCO_EN=1	TCO_STS
TCO SMI — Year 2000 Rollover	No	Yes	none	NEWCENTURY_STS
TCO SMI — TCO TIMEROUT	No	Yes	none	TIMEOUT
TCO SMI — OS writes to TCO_DAT_IN register	No	Yes	none	OS_TCO_SMI
TCO SMI — Message from (G)MCH	No	Yes	none	MCHSMI_STS
TCO SMI — NMI occurred (and NMIs mapped to SMI)	No	Yes	NMI2SMI_EN=1	NMI2SMI_STS
TCO SMI — INTRUDER# signal goes active	No	Yes	INTRD_SEL=10	INTRD_DET
TCO SMI — Change of the BIOSWP bit from 0 to 1	No	Yes	BLD=1	BIOSWR_STS
TCO SMI — Write attempted to BIOS	No	Yes	BIOSWP=1	BIOSWR_STS

Table 5-27. Causes of SMI# and SCI (Sheet 2 of 2)

Cause ¹⁻⁵	SCI	SMI	Additional Enables	Where Reported
BIOS_RLS written to	Yes	No	GBL_EN=1	GBL_STS
GBL_RLS written to	No	Yes	BIOS_EN=1	BIOS_STS
Write to B2h register	No	Yes	APMC_EN = 1	APM_STS
Periodic timer expires	No	Yes	PERIODIC_EN=1	PERIODIC_STS
64 ms timer expires	No	Yes	SWSMI_TMR_EN=1	SWSMI_TMR_STS
Enhanced USB Legacy Support Event	No	Yes	LEGACY_USB2_EN = 1	LEGACY_USB2_STS
Enhanced USB Intel Specific Event	No	Yes	INTEL_USB2_EN = 1	INTEL_USB2_STS
UHCI USB Legacy logic	No	Yes	LEGACY_USB_EN=1	LEGACY_USB_STS
Serial IRQ SMI reported	No	Yes	none	SERIRQ_SMI_STS
Device monitors match address in its range	No	Yes	none	DEVMON_STS, DEVACT_STS
SMBus Host Controller	No	Yes	SMB_SMI_EN Host Controller Enabled	SMBus host status reg.
SMBus Slave SMI message	No	Yes	none	SMBus_SMI_STS
SMBus SMBALERT# signal active	No	Yes	none	SMBus_SMI_STS
SMBus Host Notify message received	No	Yes	HOST_NOTIFY_INTREN	SMBus_SMI_STS HOST_NOTIFY_STS
(Mobile Only) BATLOW# assertion	Yes	Yes	BATLOW_EN=1.	BATLOW_STS
Access microcontroller 62h/66h	No	Yes	MCSMI_EN	MCSMI_STS
SLP_EN bit written to 1	No	Yes	SMI_ON_SLP_EN=1	SMI_ON_SLP_EN_STS

NOTES:

1. SCI_EN must be 1 to enable SCI. SCI_EN must be 0 to enable SMI.
2. SCI can be routed to cause interrupt 9:11 or 20:23 (20:23 only available in APIC mode).
3. GBL_SMI_EN must be 1 to enable SMI.
4. EOS must be written to 1 to re-enable SMI for the next 1.
5. ICH6 must have SMI# fully enabled when ICH6 is also enabled to trap cycles. If SMI# is not enabled in conjunction with the trap enabling, then hardware behavior is undefined.
6. When a power button override first occurs, the system will transition immediately to S5. The SCI will only occur after the next wake to S0 if the residual status bit (PRBTNOR_STS) is not cleared prior to setting SCI_EN.
7. Only GPI[15:0] may generate an SMI# or SCI.

5.14.4.1 PCI Express* SCI

PCI Express ports and the (G)MCH (via DMI) have the ability to cause PME using messages. When a PME message is received, ICH6 will set the PCI_EXP_STS bit. If the PCI_EXP_EN bit is also set, the ICH6 can cause an SCI via the GPE1_STS register.

5.14.4.2 PCI Express* Hot-Plug

PCI Express has a Hot-Plug mechanism and is capable of generating a SCI via the GPE1 register. It is also capable of generating an SMI. However, it is not capable of generating a wake event.

5.14.5 Dynamic Processor Clock Control

The ICH6 has extensive control for dynamically starting and stopping system clocks. The clock control is used for transitions among the various S0/Cx states, and processor throttling. Each dynamic clock control method is described in this section. The various sleep states may also perform types of non-dynamic clock control.

The ICH6 supports the ACPI C0 and C1 states (in desktop) or C0, C1, C2, C3 and C4 (in mobile) states.

The Dynamic Processor Clock control is handled using the following signals:

- STPCLK#: Used to halt processor instruction stream.
- (Mobile Only) STP_CPU#: Used to stop processor's clock
- (Mobile Only) CPUSLP#: Asserted prior to STP_CPU# (in stop grant mode)
- (Mobile Only) DPUSLP# Used to force Deeper Sleep for processor.
- (Mobile Only) DPRSLPVR: Used to lower voltage of VRM during C4 state.
- (Mobile Only) DPRSTP#: Used to lower voltage of VRM during C4 state

The C1 state is entered based on the processor performing an auto halt instruction.

(Mobile Only) The C2 state is entered based on the processor reading the Level 2 register in the ICH6. It can also be entered from C3 or C4 states if bus masters require snoops and the PUME bit (D31:F0: Offset A9h: bit 3) is set.

(Mobile Only) The C3 state is entered based on the processor reading the Level 3 register in the ICH6 and when the C4onC3_EN bit is clear (D31:F0:Offset A0:bit 7). This state can also be entered after a temporary return to C2 from a prior C3 or C4 state.

(Mobile Only) The C4 state is entered based on the processor reading the Level 4 register in the ICH6, or by reading the Level 3 register when the C4onC3_EN bit is set. This state can also be entered after a temporary return to C2 from a prior C4 state.

A C1 state in desktop or a C1, C2, C3 or C4 state in mobile ends due to a Break event. Based on the break event, the ICH6 returns the system to C0 state.

(Mobile Only) [Table 5-28](#) lists the possible break events from C2, C3 or C4. The break events from C1 are indicated in the processor's datasheet.

Table 5-28. Break Events (Mobile Only) (Sheet 1 of 2)

Event	Breaks from	Comment
Any unmasked interrupt goes active	C2, C3, C4	IRQ[0:15] when using the 8259s, IRQ[0:23] for I/O APIC. Since SCI is an interrupt, any SCI will also be a break event.
Any internal event that cause an NMI or SMI#	C2, C3, C4	Many possible sources

Table 5-28. Break Events (Mobile Only) (Sheet 2 of 2)

Event	Breaks from	Comment
Any internal event that cause INIT# to go active	C2, C3, C4	Could be indicated by the keyboard controller via the RCIN input signal.
Any bus master request (internal, external or DMA, or BMBUSY#) goes active and BM_RLD=1 (D31:F0:Offset PMBASE+04h: bit 1)	C3, C4	Need to wake up processor so it can do snoops Note: If the PUME bit (D31:F0: Offset A9h: bit 3) is set, then bus master activity will NOT be treated as a break event. Instead, there will be a return only to the C2 state.
Processor Pending Break Event Indication	C2, C3, C4	Only available if FERR# enabled for break event indication (See FERR# Mux Enable in GCS, Chipset Configuration Registers:Offset 3410h:bit 6)

5.14.5.1 Transition Rules among S0/Cx and Throttling States

The following priority rules and assumptions apply among the various S0/Cx and throttling states:

- Entry to any S0/Cx state is mutually exclusive with entry to any S1–S5 state. This is because the processor can only perform one register access at a time and Sleep states have higher priority than thermal throttling.
- When the SLP_EN bit is set (system going to a S1 - S5 sleep state), the THTL_EN and FORCE_THTL bits can be internally treated as being disabled (no throttling while going to sleep state).
- (Mobile Only) If the THTL_EN or FORCE_THTL bits are set, and a Level 2, Level 3 or Level 4 read then occurs, the system should immediately go and stay in a C2, C3 or C4 state until a break event occurs. A Level 2, Level 3 or Level 4 read has higher priority than the software initiated throttling.
- (Mobile Only) After an exit from a C2, C3 or C4 state (due to a Break event), and if the THTL_EN or FORCE_THTL bits are still set the system will continue to throttle STPCLK#. Depending on the time of break event, the first transition on STPCLK# active can be delayed by up to one THRM period (1024 PCI clocks = 30.72 μs).
- The Host controller must post Stop-Grant cycles in such a way that the processor gets an indication of the end of the special cycle prior to the ICH6 observing the Stop-Grant cycle. This ensures that the STPCLK# signals stays active for a sufficient period after the processor observes the response phase.
- (Mobile Only) If in the C1 state and the STPCLK# signal goes active, the processor will generate a Stop-Grant cycle, and the system should go to the C2 state. When STPCLK# goes inactive, it should return to the C1 state.

5.14.5.2 Deferred C3/C4 (Mobile Only)

Due to the new DMI protocol, if there is any bus master activity (other than true isoch), then the C0 to C3 transition will pause at the C2 state. ICH6 will keep the processor in a C2 state until:

- ICH6 sees no bus master activity.
- A break event occurs. In this case, the ICH6 will perform the C2 to C0 sequence. Note that bus master traffic is not a break event in this case.

To take advantage of the Deferred C3/C4 mode, the BM_STS_ZERO_EN bit must be set. This will cause the BM_STS bit to read as 0 even if some bus master activity is present. If this is not done, then the software may avoid even attempting to go to the C3 or C4 state if it sees the BM_STS bit as 1.

If the PUME bit (D31:F0: Offset A9h: bit 3) is 0, then the ICH6 will treat bus master activity as a break event. When reaching the C2 state, if there is any bus master activity, the ICH6 will return the processor to a C0 state.

5.14.5.3 POPUP (Auto C3/C4 to C2) (Mobile Only)

When the PUME bit (D31:F0: Offset A9h: bit 3) is set, the ICH6 enables a mode of operation where standard (non-isochn) bus master activity will not be treated as a full break event from the C3 or C4 states. Instead, these will be treated merely as bus master events and return the platform to a C2 state, and thus allow snoops to be performed.

After returning to the C2 state, the bus master cycles will be sent to the (G)MCH, even if the ARB_DIS bit is set.

5.14.5.4 POPDOWN (Auto C2 to C3/C4) (Mobile Only)

After returning to the C2 state from C3/C4, if the PDME bit (D31:F0: Offset A9h: bit 4) is set, the platform can return to a C3 or C4 state (depending on where it was prior to going back up to C2). This behaves similar to the Deferred C3/C4 transition, and will keep the processor in a C2 state until:

- Bus masters are no longer active.
- A break event occurs. Note that bus master traffic is not a break event in this case.

5.14.6 Dynamic PCI Clock Control (Mobile Only)

The PCI clock can be dynamically controlled independent of any other low-power state. This control is accomplished using the CLKRUN# protocol as described in the *PCI Mobile Design Guide*, and is transparent to software.

The Dynamic PCI Clock control is handled using the following signals:

- CLKRUN#: Used by PCI and LPC peripherals to request the system PCI clock to run
- STP_PCI#: Used to stop the system PCI clock

Note: The 33 MHz clock to the ICH6 is “free-running” and is not affected by the STP_PCI# signal.

5.14.6.1 Conditions for Checking the PCI Clock

When there is a lack of PCI activity the ICH6 has the capability to stop the PCI clocks to conserve power. “PCI activity” is defined as any activity that would require the PCI clock to be running.

Any of the following conditions will indicate that it is **not okay** to stop the PCI clock:

- Cycles on PCI or LPC
- Cycles of any internal device that would need to go on the PCI bus
- SERIRQ activity

Behavioral Description

- When there is a lack of activity (as defined above) for 29 PCI clocks, the ICH6 de-asserts (drive high) CLKRUN# for 1 clock and then tri-states the signal.

5.14.6.2 Conditions for Maintaining the PCI Clock

PCI masters or LPC devices that wish to maintain the PCI clock running will observe the CLKRUN# signal de-asserted, and then must re-assert if (drive it low) within 3 clocks.

- When the ICH6 has tri-stated the CLKRUN# signal after de-asserting it, the ICH6 then checks to see if the signal has been re-asserted (externally).
- After observing the CLKRUN# signal asserted for 1 clock, the ICH6 again starts asserting the signal.
- If an internal device needs the PCI bus, the ICH6 asserts the CLKRUN# signal.

5.14.6.3 Conditions for Stopping the PCI Clock

- If no device re-asserts CLKRUN# once it has been de-asserted for at least 6 clocks, the ICH6 stops the PCI clock by asserting the STP_PCI# signal to the clock synthesizer.

5.14.6.4 Conditions for Re-Starting the PCI Clock

- A peripheral asserts CLKRUN# to indicate that it needs the PCI clock re-started.
- When the ICH6 observes the CLKRUN# signal asserted for 1 (free running) clock, the ICH6 de-asserts the STP_PCI# signal to the clock synthesizer within 4 (free running) clocks.
- Observing the CLKRUN# signal asserted externally for 1 (free running) clock, the ICH6 again starts driving CLKRUN# asserted.

If an internal source requests the clock to be re-started, the ICH6 re-asserts CLKRUN#, and simultaneously de-asserts the STP_PCI# signal.

5.14.6.5 LPC Devices and CLKRUN#

If an LPC device (of any type) needs the 33 MHz PCI clock, such as for LPC DMA or LPC serial interrupt, then it can assert CLKRUN#. Note that LPC devices running DMA or bus master cycles will not need to assert CLKRUN#, since the ICH6 asserts it on their behalf.

The LDRQ# inputs are ignored by the ICH6 when the PCI clock is stopped to the LPC devices in order to avoid misinterpreting the request. The ICH6 assumes that only one more rising PCI clock edge occurs at the LPC device after the assertion of STP_PCI#. Upon de-assertion of STP_PCI#, the ICH6 assumes that the LPC device receives its first clock rising edge corresponding to the ICH6's second PCI clock rising edge after the de-assertion.

5.14.7 Sleep States

5.14.7.1 Sleep State Overview

The ICH6 directly supports different sleep states (S1–S5), which are entered by setting the SLP_EN bit, or due to a Power Button press. The entry to the Sleep states are based on several assumptions:

- Entry to a Cx state is mutually exclusive with entry to a Sleep state. This is because the processor can only perform one register access at a time. A request to Sleep always has higher priority than throttling.
- Prior to setting the SLP_EN bit, the software turns off processor-controlled throttling. Note that thermal throttling cannot be disabled, but setting the SLP_EN bit disables thermal throttling (since S1–S5 sleep state has higher priority).
- The G3 state cannot be entered via any software mechanism. The G3 state indicates a complete loss of power.

5.14.7.2 Initiating Sleep State

Sleep states (S1–S5) are initiated by:

- Masking interrupts, turning off all bus master enable bits, setting the desired type in the SLP_TYP field, and then setting the SLP_EN bit. The hardware then attempts to gracefully put the system into the corresponding Sleep state.
- Pressing the PWRBTN# Signal for more than 4 seconds to cause a Power Button Override event. In this case the transition to the S5 state is less graceful, since there are no dependencies on observing Stop-Grant cycles from the processor or on clocks other than the RTC clock.

Table 5-29. Sleep Types

Sleep Type	Comment
S1	Intel® ICH6 asserts the STPCLK# signal. It also has the option to assert CPUSLP# signal. This lowers the processor's power consumption. No snooping is possible in this state.
S3	ICH6 asserts SLP_S3#. The SLP_S3# signal controls the power to non-critical circuits. Power is only retained to devices needed to wake from this sleeping state, as well as to the memory.
S4	ICH6 asserts SLP_S3# and SLP_S4#. The SLP_S4# signal shuts off the power to the memory subsystem. Only devices needed to wake from this state should be powered.
S5	Same power state as S4. ICH6 asserts SLP_S3#, SLP_S4# and SLP_S5#.

5.14.7.3 Exiting Sleep States

Sleep states (S1–S5) are exited based on Wake events. The Wake events forces the system to a full on state (S0), although some non-critical subsystems might still be shut off and have to be brought back manually. For example, the hard disk may be shut off during a sleep state, and have to be enabled via a GPIO pin before it can be used.

Upon exit from the ICH6-controlled Sleep states, the WAK_STS bit is set. The possible causes of Wake Events (and their restrictions) are shown in [Table 5-30](#).

Note: (Mobile Only) If the BATLOW# signal is asserted, ICH6 does not attempt to wake from an S1–S5 state, even if the power button is pressed. This prevents the system from waking when the battery power is insufficient to wake the system. Wake events that occur while BATLOW# is asserted are latched by the ICH6, and the system wakes after BATLOW# is de-asserted.

Table 5-30. Causes of Wake Events

Cause ^{1,2}	States Can Wake From	How Enabled
RTC Alarm	S1–S5 ³	Set RTC_EN bit in PM1_EN register
Power Button	S1–S5	Always enabled as Wake event
GPI[0:15]	S1–S5 ³	GPE0_EN register NOTE: GPIs that are in the core well are not capable of waking the system from sleep states where the core well is not powered.
Classic USB	S1–S5	Set USB1_EN, USB 2_EN, USB3_EN, and USB4_EN bits in GPE0_EN register
LAN	S1–S5	Will use PME#. Wake enable set with LAN logic.
RI#	S1–S5 ³	Set RI_EN bit in GPE0_EN register
AC '97 / Intel High Definition Audio	S1–S5	Set AC97_EN bit in GPE0_EN register
Primary PME#	S1–S5 ³	PME_B0_EN bit in GPE0_EN register
Secondary PME#	S1–S5	Set PME_EN bit in GPE0_EN register.
PCI_EXP_WAKE#	S1–S5	PCI_EXP_WAKE bit (Note 3)
PCI_EXP PME Message	S1	Must use the PCI Express* WAKE# pin rather than messages for wake from S3,S4, or S5.
SMBALERT#	S1–S5	Always enabled as Wake event
SMBus Slave Message	S1–S5	Wake/SMI# command always enabled as a Wake event. Note: SMBus Slave Message can wake the system from S1–S5, as well as from S5 due to Power Button Override.
SMBus Host Notify message received	S1–S5	HOST_NOTIFY_WKEN bit SMBus Slave Command register. Reported in the SMB_WAK_STS bit in the GPE0_STS register.

NOTES:

1. If in the S5 state due to a powerbutton override or THRMTRIP#, the possible wake events are due to Power Button, Hard Reset Without Cycling (See Command Type 3 in [Table 5-52](#)), and Hard Reset System (See Command Type 4 in [Table 5-52](#)).
2. When the WAKE# pin is active and the PCI Express device is enabled to wake the system, the ICH6 will wake the platform.
3. This is a wake event from S5 only if the sleep state was entered by setting the SLP_EN and SLP_TYP bits via software, or if there is a power failure.

It is important to understand that the various GPIs have different levels of functionality when used as wake events. The GPIs that reside in the core power well can only generate wake events from sleep states where the core well is powered. [Table 5-31](#) summarizes the use of GPIs as wake events.

Table 5-31. GPI Wake Events

GPI	Power Well	Wake From	Notes
GPI[12, 7:0]	Core	S1	ACPI Compliant
GPI[15:13,11:8]	Resume	S1–S5	ACPI Compliant

The latency to exit the various Sleep states varies greatly and is heavily dependent on power supply design, so much so that the exit latencies due to the ICH6 are insignificant.

5.14.7.4 PCI Express* WAKE# Signal and PME Event Message

PCI Express ports can wake the platform from any sleep state (S1, S3, S4, or S5) using the WAKE# pin. WAKE# is treated as a wake event, but does not cause any bits to go active in the GPE_STS register.

PCI Express ports and the (G)MCH (via DMI) have the ability to cause PME using messages. When a PME message is received, ICH6 will set the PCI_EXP_STS bit.

5.14.7.5 Sx-G3-Sx, Handling Power Failures

Depending on when the power failure occurs and how the system is designed, different transitions could occur due to a power failure.

The AFTER_G3 bit provides the ability to program whether or not the system should boot once power returns after a power loss event. If the policy is to not boot, the system remains in an S5 state (unless previously in S4). There are only three possible events that will wake the system after a power failure.

1. **PWRBTN#:** PWRBTN# is always enabled as a wake event. When RSMRST# is low (G3 state), the PWRBTN_STS bit is reset. When the ICH6 exits G3 after power returns (RSMRST# goes high), the PWRBTN# signal is already high (because V_{CC}-standby goes high before RSMRST# goes high) and the PWRBTN_STS bit is 0.
2. **RI#:** RI# does not have an internal pull-up. Therefore, if this signal is enabled as a wake event, it is important to keep this signal powered during the power loss event. If this signal goes low (active), when power returns the RI_STS bit is set and the system interprets that as a wake event.
3. **RTC Alarm:** The RTC_EN bit is in the RTC well and is preserved after a power loss. Like PWRBTN_STS the RTC_STS bit is cleared when RSMRST# goes low.

The ICH6 monitors both PWROK and RSMRST# to detect for power failures. If PWROK goes low, the PWROK_FLR bit is set. If RSMRST# goes low, PWR_FLR is set.

Note: Although PME_EN is in the RTC well, this signal cannot wake the system after a power loss. PME_EN is cleared by RTCRST#, and PME_STS is cleared by RSMRST#.

Table 5-32. Transitions Due to Power Failure

State at Power Failure	AFTERG3_EN bit	Transition When Power Returns
S0, S1, S3	1 0	S5 S0
S4	1 0	S4 S0
S5	1 0	S5 S0

5.14.8 Thermal Management

The ICH6 has mechanisms to assist with managing thermal problems in the system.

5.14.8.1 THRM# Signal

The THRM# signal is used as a status input for a thermal sensor. Based on the THRM# signal going active, the ICH6 generates an SMI# or SCI (depending on SCI_EN). If the THRM_POL bit is set low, when the THRM# signal goes low, the THRM_STS bit will be set. This is an indicator that the thermal threshold has been exceeded. If the THRM_EN bit is set, then when THRM_STS goes active, either an SMI# or SCI will be generated (depending on the SCI_EN bit being set).

The power management software (BIOS or ACPI) can then take measures to start reducing the temperature. Examples include shutting off unwanted subsystems, or halting the processor.

By setting the THRM_POL bit to high, another SMI# or SCI can optionally be generated when the THRM# signal goes back high. This allows the software (BIOS or ACPI) to turn off the cooling methods.

Note: THRM# assertion does not cause a TCO event message in S3 or S4. The level of the signal is not reported in the heartbeat message.

5.14.8.2 Processor Initiated Passive Cooling

This mode is initiated by software setting the THTL_EN or THTL_DTY bits. Software sets the THTL_DTY bits to select throttle ratio and THTL_EN bit to enable the throttling.

Throttling results in STPCLK# active for a minimum time of 12.5% and a maximum of 87.5%. The period is 1024 PCI clocks. Thus, the STPCLK# signal can be active for as little as 128 PCI clocks or as much as 896 PCI clocks. The actual slowdown (and cooling) of the processor depends on the instruction stream, because the processor is allowed to finish the current instruction. Furthermore, the ICH6 waits for the STOP-GRANT cycle before starting the count of the time the STPCLK# signal is active.

5.14.8.3 THRM# Override Software Bit

The FORCE_THTL bit allows the BIOS to force passive cooling, independent of the ACPI software (that uses the THTL_EN and THTL_DTY bits). If this bit is set, the ICH6 starts throttling using the ratio in the THRM_DTY field.

When this bit is cleared, the ICH6 stops throttling, unless the THTL_EN bit is set (indicating that ACPI software is attempting throttling).

If both the THTL_EN and FORCE_THTL bits are set, then the ICH should use the duty cycle defined by the THRM_DTY field, not the THTL_DTY field.

5.14.8.4 Active Cooling

Active cooling involves fans. The GPIO signals from the ICH6 can be used to turn on/off a fan.

5.14.9 Event Input Signals and Their Usage

The ICH6 has various input signals that trigger specific events. This section describes those signals and how they should be used.

5.14.9.1 PWRBTN# (Power Button)

The ICH6 PWRBTN# signal operates as a “Fixed Power Button” as described in the *Advanced Configuration and Power Interface, Version 2.0b*. PWRBTN# signal has a 16 ms de-bounce on the input. The state transition descriptions are included in [Table 5-33](#). Note that the transitions start as soon as the PWRBTN# is pressed (but after the debounce logic), and does not depend on when the Power Button is released.

Note: During the time that the SLP_S4# signal is stretched for the minimum assertion width (if enabled), the Power Button is not a wake event. Refer to Power Button Override Function section below for further detail.

Table 5-33. Transitions Due to Power Button

Present State	Event	Transition/Action	Comment
S0/Cx	PWRBTN# goes low	SMI# or SCI generated (depending on SCI_EN)	Software typically initiates a Sleep state
S1–S5	PWRBTN# goes low	Wake Event. Transitions to S0 state	Standard wakeup
G3	PWRBTN# pressed	None	No effect since no power Not latched nor detected
S0–S4	PWRBTN# held low for at least 4 consecutive seconds	Unconditional transition to S5 state	No dependence on processor (e.g., Stop-Grant cycles) or any other subsystem

Power Button Override Function

If PWRBTN# is observed active for at least four consecutive seconds, the state machine should unconditionally transition to the G2/S5 state, regardless of present state (S0–S4), even if PWROK is not active. In this case, the transition to the G2/S5 state should not depend on any particular response from the processor (e.g., a Stop-Grant cycle), nor any similar dependency from any other subsystem.

The PWRBTN# status is readable to check if the button is currently being pressed or has been released. The status is taken after the de-bounce, and is readable via the PWRBTN_LVL bit.

Note: The 4-second PWRBTN# assertion should only be used if a system lock-up has occurred. The 4-second timer starts counting when the ICH6 is in a S0 state. If the PWRBTN# signal is asserted and held active when the system is in a suspend state (S1–S5), the assertion causes a wake event. Once the system has resumed to the S0 state, the 4-second timer starts.

Note: During the time that the SLP_S4# signal is stretched for the minimum assertion width (if enabled by D31:F0:A4h bit 3), the Power Button is not a wake event. As a result, it is conceivable that the user will press and continue to hold the Power Button waiting for the system to awake. Since a 4-second press of the Power Button is already defined as an Unconditional Power down, the power button timer will be forced to inactive while the power-cycle timer is in progress. Once the power-cycle timer has expired, the Power Button awakes the system. Once the minimum SLP_S4#

power cycle expires, the Power Button must be pressed for another 4 to 5 seconds to create the Override condition to S5.

Sleep Button

The *Advanced Configuration and Power Interface, Version 2.0b* defines an optional Sleep button. It differs from the power button in that it only is a request to go from S0 to S1–S4 (not S5). Also, in an S5 state, the Power Button can wake the system, but the Sleep Button cannot.

Although the ICH6 does not include a specific signal designated as a Sleep Button, one of the GPIO signals can be used to create a “Control Method” Sleep Button. See the *Advanced Configuration and Power Interface, Version 2.0b* for implementation details.

5.14.9.2 RI# (Ring Indicator)

The Ring Indicator can cause a wake event (if enabled) from the S1–S5 states. [Table 5-34](#) shows when the wake event is generated or ignored in different states. If in the G0/S0/Cx states, the ICH6 generates an interrupt based on RI# active, and the interrupt will be set up as a Break event.

Table 5-34. Transitions Due to RI# Signal

Present State	Event	RI_EN	Event
S0	RI# Active	X	Ignored
S1–S5	RI# Active	0	Ignored
		1	Wake Event

Note: Filtering/Debounce on RI# will not be done in ICH6. Can be in modem or external.

5.14.9.3 PME# (PCI Power Management Event)

The PME# signal comes from a PCI device to request that the system be restarted. The PME# signal can generate an SMI#, SCI, or optionally a Wake event. The event occurs when the PME# signal goes from high to low. No event is caused when it goes from low to high.

There is also an internal PME_B0 bit. This is separate from the external PME# signal and can cause the same effect.

5.14.9.4 SYS_RESET# Signal

When the SYS_RESET# pin is detected as active after the 16 ms debounce logic, the ICH6 attempts to perform a “graceful” reset, by waiting up to 25 ms for the SMBus to go idle. If the SMBus is idle when the pin is detected active, the reset occurs immediately; otherwise, the counter starts. If at any point during the count the SMBus goes idle the reset occurs. If, however, the counter expires and the SMBus is still active, a reset is forced upon the system even though activity is still occurring.

Once the reset is asserted, it remains asserted for 5 to 6 ms regardless of whether the SYSRESET# input remains asserted or not. It cannot occur again until SYS_RESET# has been detected inactive after the debounce logic, and the system is back to a full S0 state with PLTRST# inactive. Note that if bit 3 of the CF9h I/O register is set then SYS_RESET# will result in a full power cycle reset.

5.14.9.5 THRMTRIP# Signal

If THRMTRIP# goes active, the processor is indicating an overheat condition, and the ICH6 immediately transitions to an S5 state. However, since the processor has overheated, it does not respond to the ICH6's STPCLK# pin with a stop grant special cycle. Therefore, the ICH6 does not wait for one. Immediately upon seeing THRMTRIP# low, the ICH6 initiates a transition to the S5 state, drive SLP_S3#, SLP_S4#, SLP_S5# low, and set the CTS bit. The transition looks like a power button override.

It is extremely important that when a THRMTRIP# event occurs, the ICH6 power down immediately without following the normal S0 -> S5 path. This path may be taken in parallel, but ICH6 must immediately enter a power down state. It does this by driving SLP_S3#, SLP_S4#, and SLP_S5# immediately after sampling THRMTRIP# active.

If the processor is running extremely hot and is heating up, it is possible (although very unlikely) that components around it, such as the ICH6, are no longer executing cycles properly. Therefore, if THRMTRIP# goes active, and the ICH6 is relying on state machine logic to perform the power down, the state machine may not be working, and the system will not power down.

The ICH6 follows this flow for THRMTRIP#.

1. At boot (PLTRST# low), THRMTRIP# ignored.
2. After power-up (PLTRST# high), if THRMTRIP# sampled active, SLP_S3#, SLP_S4#, and SLP_S5# assert, and normal sequence of sleep machine starts.
3. Until sleep machine enters the S5 state, SLP_S3#, SLP_S4#, and SLP_S5# stay active, even if THRMTRIP# is now inactive. This is the equivalent of "latching" the thermal trip event.
4. If S5 state reached, go to step #1, otherwise stay here. If the ICH6 never reaches S5, the ICH6 does not reboot until power is cycled.

During boot, THRMTRIP# is ignored until SLP_S3#, PWROK, VRMPWRGD/VGATE, and PLTRST# are all '1'. During entry into a powered-down state (due to S3, S4, S5 entry, power cycle reset, etc.) THRMTRIP# is ignored until either SLP_S3# = 0, or PWROK = 0, or VRMPWRGD/VGATE = 0.

Note: A thermal trip event will:

- Set the AFTERG3_EN bit
- Clear the PWRBTN_STS bit
- Clear all the GPE0_EN register bits
- Clear the SMB_WAK_STS bit only if SMB_SAK_STS was set due to SMBus slave receiving message and not set due to SMBAlert

5.14.9.6 BMBUSY# (Mobile Only)

The BMBUSY# signal is an input from a graphics component to indicate if it is busy. If prior to going to the C3 state, the BMBUSY# signal is active, then the BM_STS bit will be set. If after going to the C3 state, the BMBUSY# signal goes back active, the ICH6 will treat this as if one of the PCI REQ# signals went active. This is treated as a break event.

5.14.10 ALT Access Mode

Before entering a low power state, several registers from powered down parts may need to be saved. In the majority of cases, this is not an issue, as registers have read and write paths. However, several of the ISA compatible registers are either read only or write only. To get data out of write-only registers, and to restore data into read-only registers, the ICH6 implements an ALT access mode.

If the ALT access mode is entered and exited after reading the registers of the ICH6 timer (8254), the timer starts counting faster (13.5 ms). The following steps listed below can cause problems:

1. BIOS enters ALT access mode for reading the ICH6 timer related registers.
2. BIOS exits ALT access mode.
3. BIOS continues through the execution of other needed steps and passes control to the operating system.

After getting control in step #3, if the operating system does not reprogram the system timer again, the timer ticks may be happening faster than expected. For example DOS and its associated software assume that the system timer is running at 54.6 ms and as a result the time-outs in the software may be happening faster than expected.

Operating systems (e.g., Microsoft Windows* 98, Windows* 2000, and Windows NT*) reprogram the system timer and therefore do not encounter this problem.

For some other loss (e.g., Microsoft MS-DOS*) the BIOS should restore the timer back to 54.6 ms before passing control to the operating system. If the BIOS is entering ALT access mode before entering the suspend state it is not necessary to restore the timer contents after the exit from ALT access mode.

5.14.10.1 Write Only Registers with Read Paths in ALT Access Mode

The registers described in Table 5-35 have read paths in ALT access mode. The access number field in the table indicates which register will be returned per access to that port.

Table 5-35. Write Only Registers with Read Paths in ALT Access Mode (Sheet 1 of 2)

Restore Data				Restore Data			
I/O Addr	# of Rds	Access	Data	I/O Addr	# of Rds	Access	Data
00h	2	1	DMA Chan 0 base address low byte	40h	7	1	Timer Counter 0 status, bits [5:0]
		2	DMA Chan 0 base address high byte			2	Timer Counter 0 base count low byte
01h	2	1	DMA Chan 0 base count low byte			3	Timer Counter 0 base count high byte
		2	DMA Chan 0 base count high byte			4	Timer Counter 1 base count low byte
02h	2	1	DMA Chan 1 base address low byte			5	Timer Counter 1 base count high byte
		2	DMA Chan 1 base address high byte			6	Timer Counter 2 base count low byte
03h	2	1	DMA Chan 1 base count low byte			7	Timer Counter 2 base count high byte
		2	DMA Chan 1 base count high byte	41h	1	Timer Counter 1 status, bits [5:0]	
04h	2	1	DMA Chan 2 base address low byte	42h	1	Timer Counter 2 status, bits [5:0]	
		2	DMA Chan 2 base address high byte	70h	1	Bit 7 = NMI Enable, Bits [6:0] = RTC Address	
05h	2	1	DMA Chan 2 base count low byte	C4h	2	1	DMA Chan 5 base address low byte
		2	DMA Chan 2 base count high byte			2	DMA Chan 5 base address high byte
06h	2	1	DMA Chan 3 base address low byte	C6h	2	1	DMA Chan 5 base count low byte
		2	DMA Chan 3 base address high byte			2	DMA Chan 5 base count high byte
07h	2	1	DMA Chan 3 base count low byte	C8h	2	1	DMA Chan 6 base address low byte
		2	DMA Chan 3 base count high byte			2	DMA Chan 6 base address high byte
08h	6	1	DMA Chan 0–3 Command ²	CAh	2	1	DMA Chan 6 base count low byte
		2	DMA Chan 0–3 Request			2	DMA Chan 6 base count high byte
		3	DMA Chan 0 Mode: Bits(1:0) = 00	CCh	2	1	DMA Chan 7 base address low byte
		4	DMA Chan 1 Mode: Bits(1:0) = 01			2	DMA Chan 7 base address high byte
		5	DMA Chan 2 Mode: Bits(1:0) = 10	CEh	2	1	DMA Chan 7 base count low byte
		6	DMA Chan 3 Mode: Bits(1:0) = 11.			2	DMA Chan 7 base count high byte

Table 5-35. Write Only Registers with Read Paths in ALT Access Mode (Sheet 2 of 2)

Restore Data				Restore Data			
I/O Addr	# of Rds	Access	Data	I/O Addr	# of Rds	Access	Data
20h	12	1	PIC ICW2 of Master controller	D0h	6	1	DMA Chan 4–7 Command ²
		2	PIC ICW3 of Master controller			2	DMA Chan 4–7 Request
		3	PIC ICW4 of Master controller			3	DMA Chan 4 Mode: Bits(1:0) = 00
		4	PIC OCW1 of Master controller ¹			4	DMA Chan 5 Mode: Bits(1:0) = 01
		5	PIC OCW2 of Master controller			5	DMA Chan 6 Mode: Bits(1:0) = 10
		6	PIC OCW3 of Master controller			6	DMA Chan 7 Mode: Bits(1:0) = 11.
		7	PIC ICW2 of Slave controller				
		8	PIC ICW3 of Slave controller				
		9	PIC ICW4 of Slave controller				
		10	PIC OCW1 of Slave controller ¹				
		11	PIC OCW2 of Slave controller				
		12	PIC OCW3 of Slave controller				

NOTES:

- 1. The OCW1 register must be read before entering ALT access mode.
- 2. Bits 5, 3, 1, and 0 return 0.

5.14.10.2 PIC Reserved Bits

Many bits within the PIC are reserved, and must have certain values written in order for the PIC to operate properly. Therefore, there is no need to return these values in ALT access mode. When reading PIC registers from 20h and A0h, the reserved bits shall return the values listed in Table 5-36.

Table 5-36. PIC Reserved Bits Return Values

PIC Reserved Bits	Value Returned
ICW2(2:0)	000
ICW4(7:5)	000
ICW4(3:2)	00
ICW4(0)	0
OCW2(4:3)	00
OCW3(7)	0
OCW3(5)	Reflects bit 6
OCW3(4:3)	01

5.14.10.3 Read Only Registers with Write Paths in ALT Access Mode

The registers described in Table 5-37 have write paths to them in ALT access mode. Software restores these values after returning from a powered down state. These registers must be handled special by software. When in normal mode, writing to the base address/count register also writes to the current address/count register. Therefore, the base address/count must be written first, then the part is put into ALT access mode and the current address/count register is written.

Table 5-37. Register Write Accesses in ALT Access Mode

I/O Address	Register Write Value
08h	DMA Status Register for channels 0–3.
D0h	DMA Status Register for channels 4–7.

5.14.11 System Power Supplies, Planes, and Signals

5.14.11.1 Power Plane Control with SLP_S3#, SLP_S4# and SLP_S5#

The usage of SLP_S3# and SLP_S4# depends on whether the platform is configured for S3_{HOT} and S3_{COLD}.

5.14.11.1.1 S3_{HOT}

The SLP_S3# output signal is used to cut power only to the processor and associated subsystems and to optionally stop system clocks.

5.14.11.1.2 S3_{COLD}

The SLP_S3# output signal can be used to cut power to the system core supply, since it only goes active for the STR state (typically mapped to ACPI S3). Power must be maintained to the ICH6 resume well, and to any other circuits that need to generate Wake signals from the STR state.

Cutting power to the core may be done via the power supply, or by external FETs to the motherboard.

The SLP_S4# or SLP_S5# output signal can be used to cut power to the system core supply, as well as power to the system memory, since the context of the system is saved on the disk. Cutting power to the memory may be done via the power supply, or by external FETs to the motherboard.

The SLP_S4# output signal is used to remove power to additional subsystems that are powered during SLP_S3#.

SLP_S5# output signal can be used to cut power to the system core supply, as well as power to the system memory, since the context of the system is saved on the disk. Cutting power to the memory may be done via the power supply, or by external FETs to the motherboard.

5.14.11.2 SLP_S4# and Suspend-To-RAM Sequencing

The system memory suspend voltage regulator is controlled by the Glue logic. The SLP_S4# signal should be used to remove power to system memory rather than the SLP_S5# signal. The SLP_S4# logic in the ICH6 provides a mechanism to fully cycle the power to the DRAM and/or detect if the power is not cycled for a minimum time.

Note: To use the minimum DRAM power-down feature that is enabled by the SLP_S4# Assertion Stretch Enable bit (D31:F0:A4h bit 3), the DRAM power must be controlled by the SLP_S4# signal.

5.14.11.3 PWROK Signal

The PWROK input should go active based on the core supply voltages becoming valid. PWROK should go active no sooner than 100 ms after Vcc3_3 and Vcc1_5 have reached their nominal values.

Note:

1. SYSRESET# is recommended for implementing the system reset button. This saves external logic that is needed if the PWROK input is used. Additionally, it allows for better handling of the SMBus and processor resets, and avoids improperly reporting power failures.
2. If the PWROK input is used to implement the system reset button, the ICH6 does not provide any mechanism to limit the amount of time that the processor is held in reset. The platform must externally guarantee that maximum reset assertion specs are met.
3. If a design has an active-low reset button electrically AND'd with the PWROK signal from the power supply and the processor's voltage regulator module the ICH6 PWROK_FLR bit will be set. The ICH6 treats this internally as if the RSMRST# signal had gone active. However, it is not treated as a full power failure. If PWROK goes inactive and then active (but RSMRST# stays high), then the ICH6 reboots (regardless of the state of the AFTERG3 bit). If the RSMRST# signal also goes low before PWROK goes high, then this is a full power failure, and the reboot policy is controlled by the AFTERG3 bit.
4. PWROK and RSMRST# are sampled using the RTC clock. Therefore, low times that are less than one RTC clock period may not be detected by the ICH6.
5. In the case of true PWROK failure, PWROK goes low first before the VRMPWRGD.

5.14.11.4 CPUPWRGD Signal

This signal is connected to the processor's VRM via the VRMPWRGD signal and is internally AND'd with the PWROK signal that comes from the system power supply.

5.14.11.5 VRMPWRGD Signal

VRMPWRGD is an input from the regulator indicating that all of the outputs from the regulator are on and within specification. VRMPWRGD may go active before or after the PWROK from the main power supply. ICH6 has no dependency on the order in which these two signals go active or inactive.

5.14.11.6 BATLOW# (Battery Low) (Mobile Only)

The BATLOW# input can inhibit waking from S3, S4, and S5 states if there is not sufficient power. It also causes an SMI# if the system is already in an S0 state.

5.14.11.7 Controlling Leakage and Power Consumption During Low-Power States

To control leakage in the system, various signals tri-state or go low during some low-power states.

General principles:

- All signals going to powered down planes (either internally or externally) must be either tri-stated or driven low.
- Signals with pull-up resistors should not be low during low-power states. This is to avoid the power consumed in the pull-up resistor.
- Buses should be halted (and held) in a known state to avoid a floating input (perhaps to some other device). Floating inputs can cause extra power consumption.

Based on the above principles, the following measures are taken:

- During S3 (STR), all signals attached to powered down planes are tri-stated or driven low.

5.14.12 Clock Generators

The clock generator is expected to provide the frequencies shown in [Table 5-38](#).

Table 5-38. Intel® ICH6 Clock Inputs

Clock Domain	Frequency	Source	Usage
SATA_CLK	100 MHz Differential	Main Clock Generator	Used by SATA controller. Stopped in S3 ~ S5 based on SLP_S3# assertion.
DMI_CLK	100 MHz Differential	Main Clock Generator	Used by DMI and PCI Express*. Stopped in S3 ~ S5 based on SLP_S3# assertion.
PCICLK	33 MHz	Main Clock Generator	Desktop: Free-running PCI Clock to ICH6. Stopped in S3 ~ S5 based on SLP_S3# assertion. Mobile: Free-running (not affected by STP_PCI# PCI Clock to ICH6. This is not the system PCI clock. This clock must keep running in S0 while the system PCI clock may stop based on CLKRUN# protocol. Stopped in S3 ~ S5 based on SLP_S3# assertion.
CLK48	48.000 MHz	Main Clock Generator	Used by USB controllers and Intel High Definition Audio controller. Stopped in S3 ~ S5 based on SLP_S3# assertion.
CLK14	14.318 MHz	Main Clock Generator	Used by ACPI timers. Stopped in S3 ~ S5 based on SLP_S3# assertion.
ACZ_BIT_CLK	12.288 MHz	AC '97 Codec	AC-link. Control policy is determined by the clock source. NOTE: Becomes clock output when Intel High Definition Audio is enabled.
LAN_CLK	0.8 to 50 MHz	LAN Connect	LAN Connect Interface. Control policy is determined by the clock source.

5.14.12.1 Clock Control Signals from Intel® ICH6 to Clock Synthesizer (Mobile Only)

The clock generator is assumed to have direct connect from the following ICH6 signals:

- STP_CPU# Stops processor clocks in C3 and C4 states
- STP_PCI# Stops system PCI clocks (not the ICH6 free-running 33 MHz clock) due to CLKRUN# protocol
- SLP_S3# Expected to drive clock chip PWRDOWN (through inverter), to stop clocks in S3_{HOT} and on the way to S3_{COLD} to S5.

5.14.13 Legacy Power Management Theory of Operation

Instead of relying on ACPI software, legacy power management uses BIOS and various hardware mechanisms. The scheme relies on the concept of detecting when individual subsystems are idle, detecting when the whole system is idle, and detecting when accesses are attempted to idle subsystems.

However, the operating system is assumed to be at least APM enabled. Without APM calls, there is no quick way to know when the system is idle between keystrokes. The ICH6 does not support burst modes.

5.14.13.1 APM Power Management (Desktop Only)

The ICH6 has a timer that, when enabled by the 1MIN_EN bit in the SMI Control and Enable register, generates an SMI# once per minute. The SMI handler can check for system activity by reading the DEVACT_STS register. If none of the system bits are set, the SMI handler can increment a software counter. When the counter reaches a sufficient number of consecutive minutes with no activity, the SMI handler can then put the system into a lower power state.

If there is activity, various bits in the DEVACT_STS register will be set. Software clears the bits by writing a 1 to the bit position.

The DEVACT_STS register allows for monitoring various internal devices, or Super I/O devices (SP, PP, FDC) on LPC or PCI, keyboard controller accesses, or audio functions on LPC or PCI. Other PCI activity can be monitored by checking the PCI interrupts.

5.14.13.2 Mobile APM Power Management (Mobile Only)

In mobile systems, there are additional requirements associated with device power management. To handle this, the ICH6 has specific SMI# traps available. The following algorithm is used:

1. The periodic SMI# timer checks if a device is idle for the require time. If so, it puts the device into a low-power state and sets the associated SMI# trap.
2. When software (not the SMI# handler) attempts to access the device, a trap occurs (the cycle does not really go to the device and an SMI# is generated).
3. The SMI# handler turns on the device and turns off the trap

The SMI# handler exits with an I/O restart. This allows the original software to continue.

5.15 System Management (D31:F0)

The ICH6 provides various functions to make a system easier to manage and to lower the Total Cost of Ownership (TCO) of the system. In addition, ICH6 provides integrated ASF Management support. Features and functions can be augmented via external A/D converters and GPIO, as well as an external microcontroller.

The following features and functions are supported by the ICH6:

- Processor present detection
 - Detects if processor fails to fetch the first instruction after reset
- Various Error detection (such as ECC Errors) Indicated by host controller
 - Can generate SMI#, SCI, SERR, NMI, or TCO interrupt
- Intruder Detect input
 - Can generate TCO interrupt or SMI# when the system cover is removed
 - INTRUDER# allowed to go active in any power state, including G3
- Detection of bad Firmware Hub programming
 - Detects if data on first read is FFh (indicates unprogrammed Firmware Hub)
- Ability to hide a PCI device
 - Allows software to hide a PCI device in terms of configuration space through the use of a device hide register (See [Section 7.1.56](#))
- Integrated ASF Management support

Note: Voltage ID from the processor can be read via GPI signals.

5.15.1 Theory of Operation

The System Management functions are designed to allow the system to diagnose failing subsystems. The intent of this logic is that some of the system management functionality be provided without the aid of an external microcontroller.

5.15.1.1 Detecting a System Lockup

When the processor is reset, it is expected to fetch its first instruction. If the processor fails to fetch the first instruction after reset, the TCO timer times out twice and the ICH6 asserts PLTRST#.

5.15.1.2 Handling an Intruder

The ICH6 has an input signal, INTRUDER#, that can be attached to a switch that is activated by the system's case being open. This input has a two RTC clock debounce. If INTRUDER# goes active (after the debouncer), this will set the INTRD_DET bit in the TCO_STS register. The INTRD_SEL bits in the TCO_CNT register can enable the ICH6 to cause an SMI# or interrupt. The BIOS or interrupt handler can then cause a transition to the S5 state by writing to the SLP_EN bit.

The software can also directly read the status of the INTRUDER# signal (high or low) by clearing and then reading the INTRD_DET bit. This allows the signal to be used as a GPI if the intruder function is not required.

If the INTRUDER# signal goes inactive some point after the INTRD_DET bit is written as a 1, then the INTRD_DET signal will go to a 0 when INTRUDER# input signal goes inactive. Note that this is slightly different than a classic sticky bit, since most sticky bits would remain active indefinitely when the signal goes active and would immediately go inactive when a 1 is written to the bit.

Note: The INTRD_DET bit resides in the ICH6's RTC well, and is set and cleared synchronously with the RTC clock. Thus, when software attempts to clear INTRD_DET (by writing a 1 to the bit location) there may be as much as two RTC clocks (about 65 μ s) delay before the bit is actually cleared. Also, the INTRUDER# signal should be asserted for a minimum of 1 ms to guarantee that the INTRD_DET bit will be set.

Note: If the INTRUDER# signal is still active when software attempts to clear the INTRD_DET bit, the bit remains set and the SMI is generated again immediately. The SMI handler can clear the INTRD_SEL bits to avoid further SMIs. However, if the INTRUDER# signal goes inactive and then active again, there will not be further SMIs, since the INTRD_SEL bits would select that no SMI# be generated.

5.15.1.3 Detecting Improper Firmware Hub Programming

The ICH6 can detect the case where the Firmware Hub is not programmed. This results in the first instruction fetched to have a value of FFh. If this occurs, the ICH6 sets the BAD_BIOS bit, which can then be reported via the Heartbeat and Event reporting using an external, Alert on LAN* enabled LAN controller (See [Section 5.15.2](#)).

5.15.2 Heartbeat and Event Reporting via SMBus

The ICH6 integrated LAN controller supports ASF heartbeat and event reporting functionality when used with the 82562EM or 82562EX Platform LAN Connect component. This allows the integrated LAN controller to report messages to a network management console without the aid of the system processor. This is crucial in cases where the processor is malfunctioning or cannot function due to being in a low-power state.

All heartbeat and event messages are sent on the SMBus interface. This allows an external LAN controller to act upon these messages if the internal LAN controller is not used.

The basic scheme is for the ICH6 integrated LAN controller to send a prepared Ethernet message to a network management console. The prepared message is stored in the non-volatile EEPROM that is connected to the ICH6.

Messages are sent by the LAN controller either because a specific event has occurred, or they are sent periodically (also known as a heartbeat). The event and heartbeat messages have the exact same format. The event messages are sent based on events occurring. The heartbeat messages are sent every 30 to 32 seconds. When an event occurs, the ICH6 sends a new message and increments the SEQ[3:0] field. For heartbeat messages, the sequence number does not increment.

The following rules/steps apply if the system is in a G0 state and the policy is for the ICH6 to **reboot** the system after a hardware lockup:

1. On detecting the lockup, the SECOND_TO_STS bit is set. The ICH6 may send up to 1 Event message to the LAN controller. The ICH6 then attempts to reboot the processor.
2. If the reboot at step 1 is successful then the BIOS should clear the SECOND_TO_STS bit. This prevents any further Heartbeats from being sent. The BIOS may then perform addition recovery/boot steps. (See note 2, below.)
3. If the reboot attempt in step 1 is not successful, the timer will timeout a third time. At this point the system has locked up and was unsuccessful in rebooting. The ICH6 does not attempt to automatically reboot again. The ICH6 starts sending a message every heartbeat period (30–32 seconds). The heartbeats continue until some external intervention occurs (reset, power failure, etc.).
4. After step 3 (unsuccessful reboot after third timeout), if the user does a Power Button Override, the system goes to an S5 state. The ICH6 continues sending the messages every heartbeat period.
5. After step 4 (power button override after unsuccessful reboot) if the user presses the Power Button again, the system should wake to an S0 state and the processor should start executing the BIOS.
6. If step 5 (power button press) is successful in waking the system, the ICH6 continues sending messages every heartbeat period until the BIOS clears the SECOND_TO_STS bit. (See note 2)
7. If step 5 (power button press) is unsuccessful in waking the system, the ICH6 continues sending a message every heartbeat period. The ICH6 does not attempt to automatically reboot again. The ICH6 starts sending a message every heartbeat period (30–32 seconds). The heartbeats continue until some external intervention occurs (reset, power failure, etc.). (See note 3)
8. After step 3 (unsuccessful reboot after third timeout), if a reset is attempted (using a button that pulses PWROK low or via the message on the SMBus slave I/F), the ICH6 attempts to reset the system.
9. After step 8 (reset attempt) if the reset is successful, the BIOS is run. The ICH6 continues sending a message every heartbeat period until the BIOS clears the SECOND_TO_STS bit. (See note 2)
10. After step 8 (reset attempt), if the reset is unsuccessful, the ICH6 continues sending a message every heartbeat period. The ICH6 does not attempt to reboot the system again without external intervention. (See note 3)

The following rules/steps apply if the system is in a G0 state and the policy is for the ICH6 to **not reboot** the system after a hardware lockup.

1. On detecting the lockup the SECOND_TO_STS bit is set. The ICH6 sends a message with the Watchdog (WD) Event status bit set (and any other bits that must also be set). This message is sent as soon as the lockup is detected, and is sent with the next (incremented) sequence number.
2. After step 1, the ICH6 sends a message every heartbeat period until some external intervention occurs.
3. Rules/steps 4–10 apply if no user intervention (resets, power button presses, SMBus reset messages) occur after a third timeout of the watchdog timer. If the intervention occurs before the third timeout, then jump to rule/step 11.
4. After step 3 (third timeout), if the user does a Power Button Override, the system goes to an S5 state. The ICH6 continues sending heartbeats at this point.

5. After step 4 (power button override), if the user presses the power button again, the system should wake to an S0 state and the processor should start executing the BIOS.
6. If step 5 (power button press) is successful in waking the system, the ICH6 continues sending heartbeats until the BIOS clears the SECOND_TO_STS bit. (See note 2)
7. If step 5 (power button press) is unsuccessful in waking the system, the ICH6 continues sending heartbeats. The ICH6 does not attempt to reboot the system again until some external intervention occurs (reset, power failure, etc.). (See note 3)
8. After step 3 (third timeout), if a reset is attempted (using a button that pulses PWROK low or via the message on the SMBus slave I/F), the ICH6 attempts to reset the system.
9. If step 8 (reset attempt) is successful, the BIOS is run. The ICH6 continues sending heartbeats until the BIOS clears the SECOND_TO_STS bit. (See note 2)
10. If step 8 (reset attempt), is unsuccessful, the ICH6 continues sending heartbeats. The ICH6 does not attempt to reboot the system again without external intervention. **Note:** A system that has locked up and can not be restarted with power button press is probably broken (bad power supply, short circuit on some bus, etc.)
11. This and the following rules/steps apply if the user intervention (power button press, reset, SMBus message, etc.) occur prior to the third timeout of the watchdog timer.
12. After step 1 (second timeout), if the user does a Power Button Override, the system goes to an S5 state. The ICH6 continues sending heartbeats at this point.
13. After step 12 (power button override), if the user presses the power button again, the system should wake to an S0 state and the processor should start executing the BIOS.
14. If step 13 (power button press) is successful in waking the system, the ICH6 continues sending heartbeats until the BIOS clears the SECOND_TO_STS bit. (See note 2)
15. If step 13 (power button press) is unsuccessful in waking the system, the ICH6 continues sending heartbeats. The ICH6 does not attempt to reboot the system again until some external intervention occurs (reset, power failure, etc.). (See note 3)
16. After step 1 (second timeout), if a reset is attempted (using a button that pulses PWROK low or via the message on the SMBus slave I/F), the ICH6 attempts to reset the system.
17. If step 16 (reset attempt) is successful, the BIOS is run. The ICH6 continues sending heartbeats until the BIOS clears the SECOND_TO_STS bit. (See note 2)
18. If step 16 (reset attempt), is unsuccessful, the ICH6 continues sending heartbeats. The ICH6 does not attempt to reboot the system again without external intervention. (See note 3)

If the system is in a G1 (S1–S4) state, the ICH6 sends a heartbeat message every 30–32 seconds. If an event occurs prior to the system being shutdown, the ICH6 immediately sends an event message with the next incremented sequence number. After the event message, the ICH6 resumes sending heartbeat messages.

Note: Notes for previous two numbered lists.

1. Normally, the ICH6 does not send heartbeat messages while in the G0 state (except in the case of a lockup). However, if a hardware event (or heartbeat) occurs just as the system is transitioning into a G0 state, the hardware continues to send the message even though the system is in a G0 state (and the status bits may indicate this).

These messages are sent via the SMBus. The ICH6 abides by the SMBus rules associated with collision detection. It delays starting a message until the bus is idle, and detects collisions. If a collision is detected the ICH6 waits until the bus is idle, and tries again.

2. **WARNING:** It is important the BIOS clears the SECOND_TO_STS bit, as the alerts interfere with the LAN device driver from working properly. The alerts reset part of the LAN controller

- and would prevent an operating system’s device driver from sending or receiving some messages.
3. A system that has locked up and can not be restarted with power button press is assumed to have broken hardware (bad power supply, short circuit on some bus, etc.), and is beyond ICH6’s recovery mechanisms.
 4. A spurious alert could occur in the following sequence:
 - The processor has initiated an alert using the SEND_NOW bit
 - During the alert, the THRM#, INTRUDER# or GPI[11] changes state
 - The system then goes to a non-S0 state.

Once the system transitions to the non-S0 state, it may send a single alert with an incremental SEQUENCE number.

5. An inaccurate alert message can be generated in the following scenario
 - The system successfully boots after a second watchdog Timeout occurs.
 - PWROK goes low (typically due to a reset button press) or a power button override occurs (before the SECOND_TO_STS bit is cleared).
 - An alert message indicating that the processor is missing or locked up is generated with a new sequence number.

Table 5-39 shows the data included in the Alert on LAN messages.

Table 5-39. Heartbeat Message Data

Field	Comment
Cover Tamper Status	1 = This bit is set if the intruder detect bit is set (INTRD_DET).
Temp Event Status	1 = This bit is set if the Intel® ICH6 THERM# input signal is asserted.
Processor Missing Event Status	1 = This bit is set if the processor failed to fetch its first instruction.
TCO Timer Event Status	1 = This bit is set when the TCO timer expires.
Software Event Status	1 = This bit is set when software writes a 1 to the SEND_NOW bit.
Unprogrammed Firmware Hub Event Status	1 = First BIOS fetch returned a value of FFh, indicating that the Firmware Hub has not yet been programmed (still erased).
GPIO Status	1 = This bit is set when GPI[11] signal is high. 0 = This bit is cleared when GPI[11] signal is low. An event message is triggered on an transition of GPI[11].
SEQ[3:0]	This is a sequence number. It initially is 0, and increments each time the ICH6 sends a new message. Upon reaching 1111, the sequence number rolls over to 0000. MSB (SEQ3) sent first.
System Power State	00 = G0, 01 = G1, 10 = G2, 11 = Pre-Boot. MSB sent first
MESSAGE1	Will be the same as the MESSAGE1 Register. MSB sent first.
MESSAGE2	Will be the same as the MESSAGE2 Register. MSB sent first.
WDSTATUS	Will be the same as the WDSTATUS Register. MSB sent first.

5.16 IDE Controller (D31:F1)

The ICH6 IDE controller features one sets of interface signals that can be enabled, tri-stated or driven low.

The IDE interfaces of the ICH6 can support several types of data transfers:

- **Programmed I/O (PIO):** Processor is in control of the data transfer.
- **8237 style DMA:** DMA protocol that resembles the DMA on the ISA bus, although it does not use the 8237 in the ICH6. This protocol off loads the processor from moving data. This allows higher transfer rate of up to 16 MB/s.
- **Ultra ATA/33:** DMA protocol that redefines signals on the IDE cable to allow both host and target throttling of data and transfer rates of up to 33 MB/s.
- **Ultra ATA/66:** DMA protocol that redefines signals on the IDE cable to allow both host and target throttling of data and transfer rates of up to 66 MB/s.
- **Ultra ATA/100:** DMA protocol that redefines signals on the IDE cable to allow both host and target throttling of data and transfer rates of up to 100 MB/s.

5.16.1 PIO Transfers

The ICH6 IDE controller includes both compatible and fast timing modes. The fast timing modes can be enabled only for the IDE data ports. All other transactions to the IDE registers are run in single transaction mode with compatible timings.

Up to two IDE devices may be attached to the IDE connector (drive 0 and drive 1). The IDE_TIMP and IDE_TIMS Registers permit different timing modes to be programmed for drive 0 and drive 1 of the same connector.

The Ultra ATA/33/66/100 synchronous DMA timing modes can also be applied to each drive by programming the IDE I/O Configuration register and the Synchronous DMA Control and Timing registers. When a drive is enabled for synchronous DMA mode operation, the DMA transfers are executed with the synchronous DMA timings. The PIO transfers are executed using compatible timings or fast timings if also enabled.

5.16.1.1 PIO IDE Timing Modes

IDE data port transaction latency consists of startup latency, cycle latency, and shutdown latency. Startup latency is incurred when a PCI master cycle targeting the IDE data port is decoded and the DA[2:0] and CSxx# lines are not set up. Startup latency provides the setup time for the DA[2:0] and CSxx# lines prior to assertion of the read and write strobes (DIOR# and DIOW#).

Cycle latency consists of the I/O command strobe assertion length and recovery time. Recovery time is provided so that transactions may occur back-to-back on the IDE interface (without incurring startup and shutdown latency) without violating minimum cycle periods for the IDE interface. The command strobe assertion width for the enhanced timing mode is selected by the IDE_TIM Register and may be set to 2, 3, 4, or 5 PCI clocks. The recovery time is selected by the IDE_TIM Register and may be set to 1, 2, 3, or 4 PCI clocks.

If IORDY is asserted when the initial sample point is reached, no wait-states are added to the command strobe assertion length. If IORDY is negated when the initial sample point is reached, additional wait-states are added. Since the rising edge of IORDY must be synchronized, at least two additional PCI clocks are added.

Shutdown latency is incurred after outstanding scheduled IDE data port transactions (either a non-empty write post buffer or an outstanding read prefetch cycles) have completed and before other transactions can proceed. It provides hold time on the DA[2:0] and CSxx# lines with respect to the read and write strobes (DIOR# and DIOW#). Shutdown latency is two PCI clocks in duration.

The IDE timings for various transaction types are shown in [Table 5-40](#).

Table 5-40. IDE Transaction Timings (PCI Clocks)

IDE Transaction Type	Startup Latency	IORDY Sample Point (ISP)	Recovery Time (RCT)	Shutdown Latency
Non-Data Port Compatible	4	11	22	2
Data Port Compatible	3	6	14	2
Fast Timing Mode	2	2–5	1–4	2

5.16.1.2 IORDY Masking

The IORDY signal can be ignored and assumed asserted at the first IORDY Sample Point (ISP) on a drive by drive basis via the IDETIM Register.

5.16.1.3 PIO 32-Bit IDE Data Port Accesses

A 32-bit PCI transaction run to the IDE data address (01F0h primary) results in two back to back 16-bit transactions to the IDE data port. The 32-bit data port feature is enabled for all timings, not just enhanced timing. For compatible timings, a shutdown and startup latency is incurred between the two, 16-bit halves of the IDE transaction. This guarantees that the chip selects are de-asserted for at least two PCI clocks between the two cycles.

5.16.1.4 PIO IDE Data Port Prefetching and Posting

The ICH6 can be programmed via the IDETIM registers to allow data to be posted to and prefetched from the IDE data ports.

Data prefetching is initiated when a data port read occurs. The read prefetch eliminates latency to the IDE data ports and allows them to be performed back to back for the highest possible PIO data transfer rates. The first data port read of a sector is called the demand read. Subsequent data port reads from the sector are called prefetch reads. The demand read and all prefetch reads must be of the same size (16 or 32 bits); software must not mix 32-bit and 16-bit reads.

Data posting is performed for writes to the IDE data ports. The transaction is completed on the PCI bus after the data is received by the ICH6. The ICH6 then runs the IDE cycle to transfer the data to the drive. If the ICH6 write buffer is non-empty and an unrelated (non-data or opposite channel) IDE transaction occurs, that transaction will be stalled until all current data in the write buffer is transferred to the drive. Only 16-bit buffer writes are supported.

5.16.2 Bus Master Function

The ICH6 can act as a PCI Bus master on behalf of an IDE device. One PCI Bus master channel is provided for the IDE connector. By performing the IDE data transfer as a PCI Bus master, the ICH6 off-loads the processor and improves system performance in multitasking environments. Both devices attached to the connector can be programmed for bus master transfers, but only one device can be active at a time.

5.16.2.1 Physical Region Descriptor Format

The physical memory region to be transferred is described by a Physical Region Descriptor (PRD). The PRDs are stored sequentially in a Descriptor Table in memory. The data transfer proceeds until all regions described by the PRDs in the table have been transferred.

Descriptor Tables must not cross a 64-KB boundary. Each PRD entry in the table is 8 bytes in length. The first 4 bytes specify the byte address of a physical memory region. This memory region must be DWord-aligned and must not cross a 64-KB boundary. The next two bytes specify the size or transfer count of the region in bytes (64-KB limit per region). A value of 0 in these two bytes indicates 64-KB (thus the minimum transfer count is 1). If bit 7 (EOT) of the last byte is a 1, it indicates that this is the final PRD in the Descriptor table. Bus master operation terminates when the last descriptor has been retired.

When the Bus Master IDE controller is reading data from the memory regions, bit 1 of the Base Address is masked and byte enables are asserted for all read transfers. When writing data, bit 1 of the Base Address is not masked and if set, will cause the lower Word byte enables to be de-asserted for the first DWord transfer. The write to PCI typically consists of a 32-byte cache line. If valid data ends prior to end of the cache line, the byte enables will be de-asserted for invalid data.

The total sum of the byte counts in every PRD of the descriptor table must be equal to or greater than the size of the disk transfer request. If greater than the disk transfer request, the driver must terminate the bus master transaction (by setting bit 0 in the Bus Master IDE Command Register to 0) when the drive issues an interrupt to signal transfer completion.

Figure 5-7. Physical Region Descriptor Table Entry

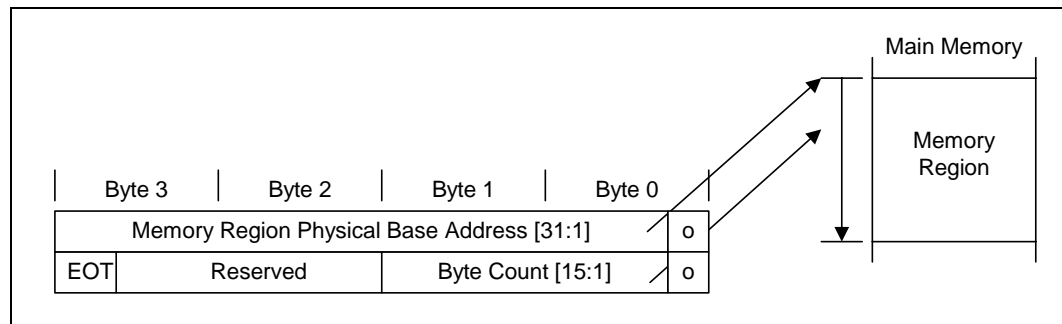

5.16.2.2 Bus Master IDE Timings

The timing modes used for Bus Master IDE transfers are identical to those for PIO transfers. The DMA Timing Enable Only bits in IDE Timing register can be used to program fast timing mode for DMA transactions only. This is useful for IDE devices whose DMA transfer timings are faster than its PIO transfer timings. The IDE device DMA request signal is sampled on the same PCI clock that DIOR# or DIOW# is de-asserted. If inactive, the DMA Acknowledge signal is de-asserted on the next PCI clock and no more transfers take place until DMA request is asserted again.

5.16.2.3 Interrupts

The ICH6 can generate interrupts based upon a signal coming from the PATA device, or due to the completion of a PRD with the 'I' bit set. The interrupt is edge triggered and active high. The PATA host controller generates IDEIRQ.

When the ICH6 IDE controller is operating independently from the SATA controller (D31:F2), IDEIRQ will generate IRQ14. When operating in conjunction with the SATA controller (combined mode), IDE interrupts will still generate IDEIRQ, but this may in turn generate either IRQ14 or IRQ15, depending upon the value of the MAP.MV (D31:F2:90h:bits 1:0) register. When in combined mode and the SATA controller is emulating the logical secondary channel (MAP.MV = 1h), the PATA channel will emulate the logical primary channel and IDEIRQ will generate IRQ14. Conversely, if the SATA controller in combined mode is emulating the logical primary channel (MAP.MV=2h), IDEIRQ will generate IRQ15.

Note: IDE interrupts cannot be communicated through PCI devices or the serial IRQ stream.

5.16.2.4 Bus Master IDE Operation

To initiate a bus master transfer between memory and an IDE device, the following steps are required:

1. Software prepares a PRD table in system memory. The PRD table must be DWord-aligned and must not cross a 64-KB boundary.
2. Software provides the starting address of the PRD Table by loading the PRD Table Pointer Register. The direction of the data transfer is specified by setting the Read/Write Control bit. The interrupt bit and Error bit in the Status register are cleared.
3. Software issues the appropriate DMA transfer command to the disk device.
4. The bus master function is engaged by software writing a 1 to the Start bit in the Command Register. The first entry in the PRD table is fetched and loaded into two registers which are not visible by software, the Current Base and Current Count registers. These registers hold the current value of the address and byte count loaded from the PRD table. The value in these registers is only valid when there is an active command to an IDE device.
5. Once the PRD is loaded internally, the IDE device will receive a DMA acknowledge.
6. The controller transfers data to/from memory responding to DMA requests from the IDE device. The IDE device and the host controller may or may not throttle the transfer several times. When the last data transfer for a region has been completed on the IDE interface, the next descriptor is fetched from the table. The descriptor contents are loaded into the Current Base and Current Count registers.
7. At the end of the transfer, the IDE device signals an interrupt.
8. In response to the interrupt, software resets the Start/Stop bit in the command register. It then reads the controller status followed by the drive status to determine if the transfer completed successfully.

The last PRD in a table has the End of List (EOL) bit set. The PCI bus master data transfers terminate when the physical region described by the last PRD in the table has been completely transferred. The active bit in the Status Register is reset and the DDRQ signal is masked.

The buffer is flushed (when in the write state) or invalidated (when in the read state) when a terminal count condition exists; that is, the current region descriptor has the EOL bit set and that region has been exhausted. The buffer is also flushed (write state) or invalidated (read state) when the Interrupt bit in the Bus Master IDE Status register is set. Software that reads the status register and finds the Error bit reset, and either the Active bit reset or the Interrupt bit set, can be assured that all data destined for system memory has been transferred and that data is valid in system memory. [Table 5-41](#) describes how to interpret the Interrupt and Active bits in the Status Register after a DMA transfer has started.

Table 5-41. Interrupt/Active Bit Interaction Definition

Interrupt	Active	Description
0	1	DMA transfer is in progress. No interrupt has been generated by the IDE device.
1	0	The IDE device generated an interrupt. The controller exhausted the Physical Region Descriptors. This is the normal completion case where the size of the physical memory regions was equal to the IDE device transfer size.
1	1	The IDE device generated an interrupt. The controller has not reached the end of the physical memory regions. This is a valid completion case where the size of the physical memory regions was larger than the IDE device transfer size.
0	0	This bit combination signals an error condition. If the Error bit in the status register is set, then the controller has some problem transferring data to/from memory. Specifics of the error have to be determined using bus-specific information. If the Error bit is not set, then the PRD's specified a smaller size than the IDE transfer size.

5.16.2.5 Error Conditions

IDE devices are sector based mass storage devices. The drivers handle errors on a sector basis; either a sector is transferred successfully or it is not. A sector is 512 bytes.

If the IDE device does not complete the transfer due to a hardware or software error, the command will eventually be stopped by the driver setting Command Start bit to 0 when the driver times out the disk transaction. Information in the IDE device registers help isolate the cause of the problem.

If the controller encounters an error while doing the bus master transfers it will stop the transfer (i.e., reset the Active bit in the Command register) and set the Error bit in the Bus Master IDE Status register. The controller does not generate an interrupt when this happens. The device driver can use device specific information (PCI Configuration Space Status register and IDE Drive Register) to determine what caused the error.

Whenever a requested transfer does not complete properly, information in the IDE device registers (Sector Count) can be used to determine how much of the transfer was completed and to construct a new PRD table to complete the requested operation. In most cases the existing PRD table can be used to complete the operation.

5.16.3 Ultra ATA/100/66/33 Protocol

The ICH6 supports Ultra ATA/100/66/33 bus mastering protocol, providing support for a variety of transfer speeds with IDE devices. Ultra ATA/33 provides transfers up to 33 MB/s, Ultra ATA/66 provides transfers at up to 44 MB/s or 66 MB/s, and Ultra ATA/100 can achieve read transfer rates up to 100 MB/s and write transfer rates up to 88.9 MB/s.

The Ultra ATA/100/66/33 definition also incorporates a Cyclic Redundancy Checking (CRC-16) error checking protocol.

5.16.3.1 Operation

Initial setup programming consists of enabling and performing the proper configuration of the ICH6 and the IDE device for Ultra ATA/100/66/33 operation. For the ICH6, this consists of enabling synchronous DMA mode and setting up appropriate Synchronous DMA timings.

When ready to transfer data to or from an IDE device, the Bus Master IDE programming model is followed. Once programmed, the drive and ICH6 control the transfer of data via the Ultra ATA/100/66/33 protocol. The actual data transfer consists of three phases, a start-up phase, a data transfer phase, and a burst termination phase.

The IDE device begins the start-up phase by asserting DMARQ signal. When ready to begin the transfer, the ICH6 asserts DMACK# signal. When DMACK# signal is asserted, the host controller drives CS0# and CS1# inactive, DA0–DA2 low. For write cycles, the ICH6 de-asserts STOP, waits for the IDE device to assert DMARDY#, and then drives the first data word and STROBE signal. For read cycles, the ICH6 tri-states the DD lines, de-asserts STOP, and asserts DMARDY#. The IDE device then sends the first data word and STROBE.

The data transfer phase continues the burst transfers with the data transmitter (ICH6 – writes, IDE device – reads) providing data and toggling STROBE. Data is transferred (latched by receiver) on each rising and falling edge of STROBE. The transmitter can pause the burst by holding STROBE high or low, resuming the burst by again toggling STROBE. The receiver can pause the burst by de-asserting DMARDY# and resumes the transfers by asserting DMARDY#. The ICH6 pauses a burst transaction to prevent an internal line buffer over or under flow condition, resuming once the condition has cleared. It may also pause a transaction if the current PRD byte count has expired, resuming once it has fetched the next PRD.

The current burst can be terminated by either the transmitter or receiver. A burst termination consists of a Stop Request, Stop Acknowledge and transfer of CRC data. The ICH6 can stop a burst by asserting STOP, with the IDE device acknowledging by de-asserting DMARQ. The IDE device stops a burst by de-asserting DMARQ and the ICH6 acknowledges by asserting STOP. The transmitter then drives the STROBE signal to a high level. The ICH6 then drives the CRC value onto the DD lines and de-assert DMACK#. The IDE device latches the CRC value on rising edge of DMACK#. The ICH6 terminates a burst transfer if it needs to service the opposite IDE channel, if a Programmed I/O (PIO) cycle is executed to the IDE channel currently running the burst, or upon transferring the last data from the final PRD.

5.16.4 Ultra ATA/33/66/100 Timing

The timings for Ultra ATA/33/66/100 modes are programmed via the Synchronous DMA Timing register and the IDE Configuration register. Different timings can be programmed for each drive in the system. The Base Clock frequency for each drive is selected in the IDE Configuration register. The Cycle Time (CT) and Ready to Pause (RP) time (defined as multiples of the Base Clock) are programmed in the Synchronous DMA Timing Register. The Cycle Time represents the minimum pulse width of the data strobe (STROBE) signal. The Ready to Pause time represents the number of Base Clock periods that the ICH6 waits from de-assertion of DMARDY# to the assertion of STOP when it desires to stop a burst read transaction.

Note: The internal Base Clock for Ultra ATA/100 (Mode 5) runs at 133 MHz, and the Cycle Time (CT) must be set for three Base Clocks. The ICH6 thus toggles the write strobe signal every 22.5 ns, transferring two bytes of data on each strobe edge. This means that the ICH6 performs Mode 5 write transfers at a maximum rate of 88.9 MB/s. For read transfers, the read strobe is driven by the ATA/100 device, and the ICH6 supports reads at the maximum rate of 100 MB/s.

5.16.5 ATA Swap Bay

To support PATA swap bay, the ICH6 allows the IDE output signals to be tri-stated and input buffers to be turned off. This should be done prior to the removal of the drive. The output signals can also be driven low. This can be used to remove charge built up on the signals. Configuration bits are included in the IDE I/O Configuration register, offset 54h in the IDE PCI configuration space.

In a PATA swap bay operation, an IDE device is removed and a new one inserted while the IDE interface is powered down and the rest of the system is in a fully powered-on state (SO). During a PATA swap bay operation, if the operating system executes cycles to the IDE interface after it has been powered down it will cause the ICH6 to hang the system that is waiting for IORDY to be asserted from the drive.

To correct this issue, the following BIOS procedures are required for performing an IDE swap:

1. Program IDE SIG_MODE (Configuration register at offset 54h) to 10b (drive low mode).
2. Clear IORDY Sample Point Enable (bits 1 or 5 of IDE Timing reg.). This prevents the ICH6 from waiting for IORDY assertion when the operating system accesses the IDE device after the IDE drive powers down, and ensures that 0s are always be returned for read cycles that occur during swap operation.

Warning: Software should **not** attempt to control the outputs (either tri-state or driving low), while an IDE transfer is in progress. Unpredictable results could occur, including a system lockup.

5.16.6 SMI Trapping

Device 31:Function 1: Offset C0h (see [Section 11.1.26](#)) contain control for generating SMI# on accesses to the IDE I/O spaces. These bits map to the legacy ranges (1F0–1F7h and 3F6h). Accesses to one of these ranges with the appropriate bit set causes the cycle to not be forwarded to the IDE controller, and for an SMI# to be generated. If an access to the Bus-Master IDE registers occurs while trapping is enabled for the device being accessed, then the register is updated, an SMI# is generated, and the device activity status bits (Device 31:Function 1:Offset C4h) are updated indicating that a trap occurred.

5.17 SATA Host Controller (D31:F2)

The SATA function in the ICH6 has dual modes of operation to support different operating system conditions. In the case of Native IDE enabled operating systems, the ICH6 has separate PCI functions for serial and parallel ATA (“enhanced mode”). To support legacy operating systems, there is only one PCI function for both the serial and parallel ATA ports if functionality from both SATA and PATA devices is desired (“combined mode”).

The MAP register, [Section 12.1.29](#), provides the ability to share PCI functions. When sharing is enabled, all decode of I/O is done through the SATA registers. Device 31, Function 1 (IDE controller) is hidden by software writing to the Function Disable Register (D31, F0, offset F2h, bit 1), and its configuration registers are not used.

The ICH6 SATA controller features four (desktop only) / two (mobile only) sets of interface signals (ports) that can be independently enabled or disabled (they cannot be tri-stated or driven low). Each interface is supported by an independent DMA controller.

The ICH6 SATA controller interacts with an attached mass storage device through a register interface that is equivalent to that presented by a traditional IDE host adapter. The host software follows existing standards and conventions when accessing the register interface and follows standard command protocol conventions.

Note: SATA interface transfer rates are independent of UDMA mode settings. SATA interface transfer rates will operate at the bus’s maximum speed, regardless of the UDMA mode reported by the SATA device or the system BIOS.

5.17.1 Theory of Operation

5.17.1.1 Standard ATA Emulation

The ICH6 contains a set of registers that shadow the contents of the legacy IDE registers. The behavior of the Command and Control Block registers, PIO, and DMA data transfers, resets, and interrupts are all emulated.

Note: The ICH6 requires that software wait for BSY=0 and DRDY=1 after drive power-up before writing to the Device Control Register. Further, it is recommended that software perform the following steps for each SATA channel before unmasking the SATA controller’s IRQ:

1. Read the (Task File) Status Register of each attached device.
2. Read the existing Bus Master Status register value.
3. OR that value with 4
4. Write the resulting value back to the Bus Master Status register.

The ICH6 will assert INTR when the master device completes the EDD (Execute Device Diagnostics) command regardless of the command completion status of the slave device. If the master completes EDD first, an INTR is generated and BSY will remain ‘1’ until the slave completes the command. If the slave completes EDD first, BSY will be ‘0’ when the master completes the EDD command and asserts INTR. Software must wait for BSY to clear before completing an EDD command, as required by the ATA5 through ATA7 (T13) industry specifications.

5.17.1.2 48-Bit LBA Operation

The SATA host controller supports 48-bit LBA through the host-to-device register FIS when accesses are performed via writes to the task file. The SATA host controller will ensure that the correct data is put into the correct byte of the host-to-device FIS.

There are special considerations when reading from the task file to support 48-bit LBA operation. Software may need to read all 16-bits. Since the registers are only 8-bits wide and act as a FIFO, a bit must be set in the device/control register, which is at offset 3F6h for primary and 376h for secondary (or their native counterparts).

If software clears bit 7 of the control register before performing a read, the last item written will be returned from the FIFO. If software sets bit 7 of the control register before performing a read, the first item written will be returned from the FIFO.

5.17.2 SATA Swap Bay Support

Dynamic Hot-Plug (e.g., surprise removal) is not supported by the SATA host controller without special support from AHCI and the proper board hardware. However, the ICH6 does provide for basic SATA swap bay support using the PSC register configuration bits and power management flows. A device can be powered down by software and the port can then be disabled, allowing removal and insertion of a new device.

Note: This SATA swap bay operation requires board hardware (implementation specific), BIOS, and operating system support.

5.17.3 Intel® Matrix Storage Technology Configuration (ICH6R Only)

The Intel Matrix Storage Technology solution offers data striping for higher performance (RAID Level 0), alleviating disk bottlenecks by taking advantage of the independent DMA engines that each SATA port offers in the ICH6R. Intel Matrix Storage Technology also offers mirroring for data security (RAID Level 1). There is no loss of PCI resources (request/grant pair) or add-in card slot.

Intel Matrix Storage Technology functionality requires the following items:

- ICH6R
- Intel® Application Accelerator RAID Option ROM must be on the platform
- Intel Application Accelerator RAID Edition drivers, most recent revision.
- Two SATA hard disk drives.

Intel Matrix Storage Technology is not available in the following configurations:

- The SATA controller in compatible mode.

5.17.3.1 Intel® Application Accelerator RAID Option ROM

The Intel Application Accelerator RAID Option ROM is a standard PnP Option ROM that is easily integrated into any System BIOS. When in place, it provides the following three primary functions:

- Provides a text mode user interface that allows the user to manage the RAID configuration on the system in a pre-operating system environment. Its feature set is kept simple to keep size to a minimum, but allows the user to create & delete RAID volumes and select recovery options when problems occur.
- Provides boot support when using a RAID volume as a boot disk. It does this by providing Int13 services when a RAID volume needs to be accessed by DOS applications (such as NTLDR) and by exporting the RAID volumes to the System BIOS for selection in the boot order.
- At each boot up, provides the user with a status of the RAID volumes and the option to enter the user interface by pressing CTRL-I.

5.17.4 Power Management Operation

Power management of the ICH6 SATA controller and ports will cover operations of the host controller and the SATA wire.

5.17.4.1 Power State Mappings

The D0 PCI power management state for device is supported by the ICH6 SATA controller.

SATA devices may also have multiple power states. From parallel ATA, three device states are supported through ACPI. They are:

- **D0** – Device is working and instantly available.
- **D1** – device enters when it receives a STANDBY IMMEDIATE command. Exit latency from this state is in seconds
- **D3** – from the SATA device’s perspective, no different than a D1 state, in that it is entered via the STANDBY IMMEDIATE command. However, an ACPI method is also called which will reset the device and then cut its power.

Each of these device states are subsets of the host controller’s D0 state.

Finally, SATA defines three PHY layer power states, that have no equivalent mappings to parallel ATA. They are:

- **PHY READY** – PHY logic and PLL are both on and active
- **Partial** – PHY logic is powered, but in a reduced state. Exit latency is no longer than 10 ns
- **Slumber** – PHY logic is powered, but in a reduced state. Exit latency can be up to 10 ms.

Since these states have much lower exit latency than the ACPI D1 and D3 states, the SATA controller defines these states as sub-states of the device D0 state.

Figure 5-8. SATA Power States

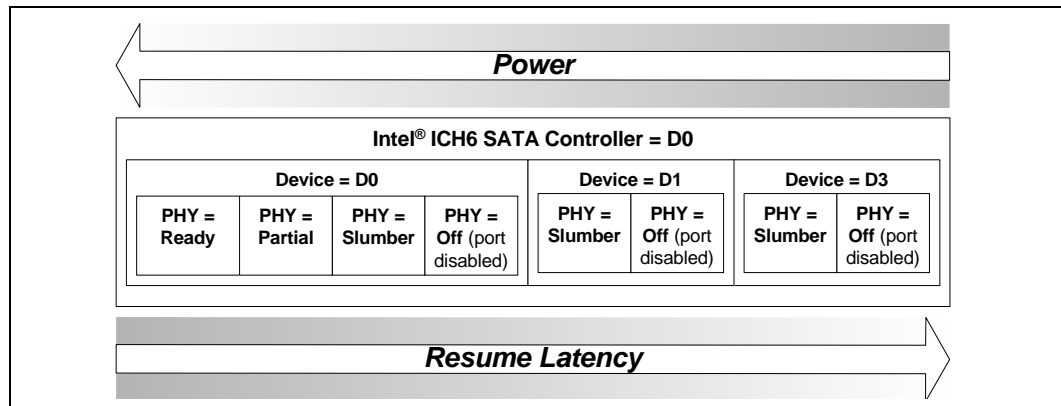

5.17.4.2 Power State Transitions

5.17.4.2.1 Partial and Slumber State Entry/Exit

The partial and slumber states save interface power when the interface is idle. It would be most analogous to PCI CLKRUN# (in power savings, not in mechanism), where the interface can have power saved while no commands are pending. The SATA controller defines PHY layer power management (as performed via primitives) as a driver operation from the host side, and a device proprietary mechanism on the device side. The SATA controller accepts device transition types, but does not issue any transitions as a host. All received requests from a SATA device will be ACKed.

When an operation is performed to the SATA controller such that it needs to use the SATA cable, the controller must check whether the link is in the Partial or Slumber states, and if so, must issue a COM_WAKE to bring the link back online. Similarly, the SATA device must perform the same action.

5.17.4.2.2 Device D1, D3 States

These states are entered after some period of time when software has determined that no commands will be sent to this device for some time. The mechanism for putting a device in these states does not involve any work on the host controller, other than sending commands over the interface to the device. The command most likely to be used in ATA/ATAPI is the “STANDBY IMMEDIATE” command.

5.17.4.2.3 Host Controller D3_{HOT} State

After the interface and device have been put into a low power state, the SATA host controller may be put into a low power state. This is performed via the PCI power management registers in configuration space. There are two very important aspects to note when using PCI power management.

- When the power state is D3, only accesses to configuration space are allowed. Any attempt to access the memory or I/O spaces will result in master abort.
- When the power state is D3, no interrupts may be generated, even if they are enabled. If an interrupt status bit is pending when the controller transitions to D0, an interrupt may be generated.

When the controller is put into D3, it is assumed that software has properly shut down the device and disabled the ports. Therefore, there is no need to sustain any values on the port wires. The interface will be treated as if no device is present on the cable, and power will be minimized.

When returning from a D3 state, an internal reset will not be performed.

5.17.4.2.4 Non-AHCI Mode PME# Generation

When in non-AHCI mode (legacy mode) of operation, the SATA controller does not generate PME#. This includes attach events (since the port must be disabled), or interlock switch events (via the SATAGP pins).

5.17.4.3 SMI Trapping (APM)

Device 31:Function2:Offset C0h (see [Section 12.1.40](#)) contain control for generating SMI# on accesses to the IDE I/O spaces. These bits map to the legacy ranges (1F0–1F7h, 3F6h, 170–177h, and 376h). If the SATA controller is in legacy mode and is using these addresses, accesses to one of these ranges with the appropriate bit set causes the cycle to not be forwarded to the SATA controller, and for an SMI# to be generated. If an access to the Bus-Master IDE registers occurs while trapping is enabled for the device being accessed, then the register is updated, an SMI# is generated, and the device activity status bits ([Section 12.1.41](#)) are updated indicating that a trap occurred.

5.17.5 SATA LED

The SATALED# output is driven when the BSY bit is set in any SATA port. The SATALED# is an active-low open-collector output. When SATALED# is low, the LED should be active. When SATALED# is high, the LED should be inactive.

5.17.6 AHCI Operation

The ICH6R/ICH6-M provides hardware support for Advanced Host Controller Interface (AHCI), a new programming interface for SATA host controllers developed thru a joint industry effort. AHCI defines transactions between the ICH6R/ICH6-M SATA controller and software and enables advanced performance and usability with SATA. Platforms supporting AHCI may take advantage of performance features such as no master/slave designation for SATA devices—each device is treated as a master—and hardware assisted native command queuing. AHCI also provides usability enhancements (such as Hot-Plug). AHCI requires appropriate software support (e.g., an AHCI driver) and for some features, hardware support in the SATA device or additional platform hardware.

The ICH6R/ICH6-M supports all of the mandatory features of the *Serial ATA Advanced Host Controller Interface* specification, rev 1.0 and many optional features, such as hardware assisted native command queuing, aggressive power management, LED indicator support, and Hot-Plug thru the use of interlock switch support (additional platform hardware and software may be required depending upon the implementation).

Note: For reliable device removal notification while in AHCI operation without the use of interlock switches (surprise removal), interface power management should be disabled for the associated port. See section 7.3.1 of the AHCI Specification for more information.

5.18 High Precision Event Timers

This function provides a set of timers that can be used by the operating system. The timers are defined such that in the future, the operating system may be able to assign specific timers to used directly by specific applications. Each timer can be configured to cause a separate interrupt.

ICH6 provides three timers. The three timers are implemented as a single counter each with its own comparator and value register. This counter increases monotonically. Each individual timer can generate an interrupt when the value in its value register matches the value in the main counter.

The registers associated with these timers are mapped to a memory space (much like the I/O APIC). However, it is not implemented as a standard PCI function. The BIOS reports to the operating system the location of the register space. The hardware can support an assignable decode space; however, the BIOS sets this space prior to handing it over to the operating system (See Section 6.4). It is not expected that the operating system will move the location of these timers once it is set by the BIOS.

5.18.1 Timer Accuracy

1. The timers are accurate over any 1 ms period to within 0.05% of the time specified in the timer resolution fields.
2. Within any 100 microsecond period, the timer reports a time that is up to two ticks too early or too late. Each tick is less than or equal to 100 ns, so this represents an error of less than 0.2%.
3. The timer is monotonic. It does not return the same value on two consecutive reads (unless the counter has rolled over and reached the same value).

The main counter is clocked by the 14.31818 MHz clock, synchronized into the 66.666 MHz domain. This results in a non-uniform duty cycle on the synchronized clock, but does have the correct average period. The accuracy of the main counter is as accurate as the 14.3818 MHz clock.

5.18.2 Interrupt Mapping

Mapping Option #1 (Legacy Replacement Option)

In this case, the Legacy Replacement Rout bit (LEG_RT_CNF) is set. This forces the mapping found in Table 5-42.

Table 5-42. Legacy Replacement Routing

Timer	8259 Mapping	APIC Mapping	Comment
0	IRQ0	IRQ2	In this case, the 8254 timer will not cause any interrupts
1	IRQ8	IRQ8	In this case, the RTC will not cause any interrupts.
2	Per IRQ Routing Field.	Per IRQ Routing Field	

Mapping Option #2 (Standard Option)

In this case, the Legacy Replacement Rout bit (LEG_RT_CNF) is 0. Each timer has its own routing control. The supported interrupt values are IRQ 20, 21, 22, and 23.

5.18.3 Periodic vs. Non-Periodic Modes

Non-Periodic Mode

Timer 0 is configurable to 32 (default) or 64-bit mode, whereas Timers 1 and 2 only support 32-bit mode (See [Section 20.1.5](#)).

All three timers support non-periodic mode.

Consult section 2.3.9.2.1 of the IA-PC HPET Specification for a description of this mode.

Periodic Mode

Timer 0 is the only timer that supports periodic mode. Consult section 2.3.9.2.2 of the IA-PC HPET Specification for a description of this mode.

The following usage model is expected:

1. Software clears the ENABLE_CNF bit to prevent any interrupts
2. Software Clears the main counter by writing a value of 00h to it.
3. Software sets the TIMER0_VAL_SET_CNF bit.
4. Software writes the new value in the TIMER0_COMPARATOR_VAL register
5. Software sets the ENABLE_CNF bit to enable interrupts.

The Timer 0 Comparator Value register cannot be programmed reliably by a single 64-bit write in a 32-bit environment except if only the periodic rate is being changed during run-time. If the actual Timer 0 Comparator Value needs to be reinitialized, then the following software solution will always work regardless of the environment:

1. Set TIMER0_VAL_SET_CNF bit
2. Set the lower 32 bits of the Timer0 Comparator Value register
3. Set TIMER0_VAL_SET_CNF bit
4. 4) Set the upper 32 bits of the Timer0 Comparator Value register

5.18.4 Enabling the Timers

The BIOS or operating system PnP code should route the interrupts. This includes the Legacy Rout bit, Interrupt Rout bit (for each timer), interrupt type (to select the edge or level type for each timer)

The Device Driver code should do the following for an available timer:

1. Set the Overall Enable bit (Offset 04h, bit 0).
2. Set the timer type field (selects one-shot or periodic).
3. Set the interrupt enable
4. Set the comparator value

5.18.5 Interrupt Levels

Interrupts directed to the internal 8259s are active high. See [Section 5.10](#) for information regarding the polarity programming of the I/O APIC for detecting internal interrupts.

If the interrupts are mapped to the I/O APIC and set for level-triggered mode, they can be shared with PCI interrupts. This may be shared although it's unlikely for the operating system to attempt to do this.

If more than one timer is configured to share the same IRQ (using the `TIMERn_INT_ROUT_CNF` fields), then the software must configure the timers to level-triggered mode. Edge-triggered interrupts cannot be shared.

5.18.6 Handling Interrupts

If each timer has a unique interrupt and the timer has been configured for edge-triggered mode, then there are no specific steps required. No read is required to process the interrupt.

If a timer has been configured to level-triggered mode, then its interrupt must be cleared by the software. This is done by reading the interrupt status register and writing a 1 back to the bit position for the interrupt to be cleared.

Independent of the mode, software can read the value in the main counter to see how time has passed between when the interrupt was generated and when it was first serviced.

If Timer 0 is set up to generate a periodic interrupt, the software can check to see how much time remains until the next interrupt by checking the timer value register.

5.18.7 Issues Related to 64-Bit Timers with 32-Bit Processors

A 32-bit timer can be read directly using processors that are capable of 32-bit or 64-bit instructions. However, a 32-bit processor may not be able to directly read 64-bit timer. A race condition comes up if a 32-bit processor reads the 64-bit register using two separate 32-bit reads. The danger is that just after reading one half, the other half rolls over and changes the first half.

If a 32-bit processor needs to access a 64-bit timer, it must first halt the timer before reading both the upper and lower 32-bits of the timer. If a 32-bit processor does not want to halt the timer, it can use the 64-bit timer as a 32-bit timer by setting the `TIMERn_32MODE_CNF` bit. This causes the timer to behave as a 32-bit timer. The upper 32-bits are always 0.

5.19 USB UHCI Host Controllers (D29:F0, F1, F2, and F3)

The ICH6 contains four USB 2.0 full/low-speed host controllers that support the standard Universal Host Controller Interface (UHCI), Revision 1.1. Each UHCI Host Controller (UHC) includes a root hub with two separate USB ports each, for a total of eight USB ports.

- Overcurrent detection on all eight USB ports is supported. The overcurrent inputs are *not* 5 V tolerant, and can be used as GPIOs if not needed.
- The ICH6's UHCI host controllers are arbitrated differently than standard PCI devices to improve arbitration latency.
- The UHCI controllers use the Analog Front End (AFE) embedded cell that allows support for USB full-speed signaling rates, instead of USB I/O buffers.

5.19.1 Data Structures in Main Memory

Section 3.1 - 3.3 of the *Universal Host Controller Interface, Revision 1.1* specification details the data structures used to communicate control, status, and data between software and the ICH6.

5.19.2 Data Transfers to/from Main Memory

Section 3.4 of the *Universal Host Controller Interface, Revision 1.1* specification describes the details on how HCD and the ICH6 communicate via the Schedule data structures.

5.19.3 Data Encoding and Bit Stuffing

The ICH6 USB employs NRZI data encoding (Non-Return to Zero Inverted) when transmitting packets. Full details on this implementation are given in the *Universal Serial Bus Revision 2.0 Specification*.

5.19.4 Bus Protocol

5.19.4.1 Bit Ordering

Bits are sent out onto the bus least significant bit (LSb) first, followed by next LSb, through to the most significant bit (MSb) last.

5.19.4.2 SYNC Field

All packets begin with a synchronization (SYNC) field, which is a coded sequence that generates a maximum edge transition density. The SYNC field appears on the bus as IDLE followed by the binary string "KJKJKJJK," in its NRZI encoding. It is used by the input circuitry to align incoming data with the local clock and is defined to be 8 bits in length. SYNC serves only as a synchronization mechanism and is not shown in the following packet diagrams. The last two bits in the SYNC field are a marker that is used to identify the first bit of the PID. All subsequent bits in the packet must be indexed from this point.

5.19.4.3 Packet Field Formats

All packets have distinct start and end of packet delimiters. Full details are given in the *Universal Serial Bus Revision 2.0 Specification* in section 8.3.1.

5.19.4.4 Address Fields

Function endpoints are addressed using the function address field and the endpoint field. Full details on this are given in the *Universal Serial Bus Revision 2.0 Specification* in section 8.3.2.

5.19.4.5 Frame Number Field

The frame number field is an 11-bit field that is incremented by the host on a per frame basis. The frame number field rolls over upon reaching its maximum value of 7FFh, and is sent only for SOF tokens at the start of each frame.

5.19.4.6 Data Field

The data field may range from 0 to 1023 bytes and must be an integral numbers of bytes. Data bits within each byte are shifted out LSB first.

5.19.4.7 Cyclic Redundancy Check (CRC)

CRC is used to protect the all non-PID fields in token and data packets. In this context, these fields are considered to be protected fields. Full details on this are given in the *Universal Serial Bus Revision 2.0 Specification* in section 8.3.5.

5.19.5 Packet Formats

The USB protocol calls out several packet types: token, data, and handshake packets. Full details on this are given in the *Universal Serial Bus Revision 2.0 Specification* in section 8.4.

5.19.6 USB Interrupts

There are two general groups of USB interrupt sources, those resulting from execution of transactions in the schedule, and those resulting from an ICH6 operation error. All transaction-based sources can be masked by software through the ICH6's Interrupt Enable register. Additionally, individual transfer descriptors can be marked to generate an interrupt on completion.

When the ICH6 drives an interrupt for USB, it internally drives the PIRQA# pin for USB function #0 and USB function #3, PIRQD# pin for USB function #1, and the PIRQC# pin for USB function #2, until all sources of the interrupt are cleared. In order to accommodate some operating systems, the Interrupt Pin register must contain a different value for each function of this new multi-function device.

5.19.6.1 Transaction-Based Interrupts

These interrupts are not signaled until after the status for the last complete transaction in the frame has been written back to host memory. This guarantees that software can safely process through (Frame List Current Index -1) when it is servicing an interrupt.

CRC Error / Time-Out

A CRC/Time-Out error occurs when a packet transmitted from the ICH6 to a USB device or a packet transmitted from a USB device to the ICH6 generates a CRC error. The ICH6 is informed of this event by a time-out from the USB device or by the ICH6's CRC checker generating an error on reception of the packet. Additionally, a USB bus time-out occurs when USB devices do not respond to a transaction phase within 19-bit times of an EOP. Either of these conditions causes the C_ERR field of the TD to decrement.

When the C_ERR field decrements to 0, the following occurs:

- The Active bit in the TD is cleared
- The Stalled bit in the TD is set
- The CRC/Time-out bit in the TD is set.
- At the end of the frame, the USB Error Interrupt bit is set in the HC status register.

If the CRC/Time out interrupt is enabled in the Interrupt Enable register, a hardware interrupt will be signaled to the system.

Interrupt on Completion

Transfer Descriptors contain a bit that can be set to cause an interrupt on their completion. The completion of the transaction associated with that block causes the USB Interrupt bit in the HC Status Register to be set at the end of the frame in which the transfer completed. When a TD is encountered with the IOC bit set to 1, the IOC bit in the HC Status register is set to 1 at the end of the frame if the active bit in the TD is set to 0 (even if it was set to 0 when initially read).

If the IOC Enable bit of Interrupt Enable register (bit 2 of I/O offset 04h) is set, a hardware interrupt is signaled to the system. The USB Interrupt bit in the HC status register is set either when the TD completes successfully or because of errors. If the completion is because of errors, the USB Error bit in the HC status register is also set.

Short Packet Detect

A transfer set is a collection of data which requires more than one USB transaction to completely move the data across the USB. An example might be a large print file which requires numerous TDs in multiple frames to completely transfer the data. Reception of a data packet that is less than the endpoint's Max Packet size during Control, Bulk or Interrupt transfers signals the completion of the transfer set, even if there are active TDs remaining for this transfer set. Setting the SPD bit in a TD indicates to the HC to set the USB Interrupt bit in the HC status register at the end of the frame in which this event occurs. This feature streamlines the processing of input on these transfer types. If the Short Packet Interrupt Enable bit in the Interrupt Enable register is set, a hardware interrupt is signaled to the system at the end of the frame where the event occurred.

Serial Bus Babble

When a device transmits on the USB for a time greater than its assigned Max Length, it is said to be babbling. Since isochrony can be destroyed by a babbling device, this error results in the Active bit in the TD being cleared to 0 and the Stalled and Babble bits being set to 1. The C_ERR field is not decremented for a babble. The USB Error Interrupt bit in the HC Status register is set to 1 at the end of the frame. A hardware interrupt is signaled to the system.

If an EOF babble was caused by the ICH6 (due to incorrect schedule for instance), the ICH6 forces a bit stuff error followed by an EOP and the start of the next frame.

Stalled

This event indicates that a device/endpoint returned a STALL handshake during a transaction or that the transaction ended in an error condition. The TDs Stalled bit is set and the Active bit is cleared. Reception of a STALL does not decrement the error counter. A hardware interrupt is signaled to the system.

Data Buffer Error

This event indicates that an overrun of incoming data or a under-run of outgoing data has occurred for this transaction. This would generally be caused by the ICH6 not being able to access required data buffers in memory within necessary latency requirements. Either of these conditions causes the C_ERR field of the TD to be decremented.

When C_ERR decrements to 0, the Active bit in the TD is cleared, the Stalled bit is set, the USB Error Interrupt bit in the HC Status register is set to 1 at the end of the frame and a hardware interrupt is signaled to the system.

Bit Stuff Error

A bit stuff error results from the detection of a sequence of more than six 1s in a row within the incoming data stream. This causes the C_ERR field of the TD to be decremented. When the C_ERR field decrements to 0, the Active bit in the TD is cleared to 0, the Stalled bit is set to 1, the USB Error Interrupt bit in the HC Status register is set to 1 at the end of the frame and a hardware interrupt is signaled to the system.

5.19.6.2 Non-Transaction Based Interrupts

If an ICH6 process error or system error occur, the ICH6 halts and immediately issues a hardware interrupt to the system.

Resume Received

This event indicates that the ICH6 received a RESUME signal from a device on the USB bus during a global suspend. If this interrupt is enabled in the Interrupt Enable register, a hardware interrupt is signaled to the system allowing the USB to be brought out of the suspend state and returned to normal operation.

ICH6 Process Error

The HC monitors certain critical fields during operation to ensure that it does not process corrupted data structures. These include checking for a valid PID and verifying that the MaxLength field is less than 1280. If it detects a condition that would indicate that it is processing corrupted data structures, it immediately halts processing, sets the HC Process Error bit in the HC Status register and signals a hardware interrupt to the system.

This interrupt cannot be disabled through the Interrupt Enable register.

Host System Error

The ICH6 sets this bit to 1 when a Parity error, Master Abort, or Target Abort occur. When this error occurs, the ICH6 clears the Run/Stop bit in the Command register to prevent further execution of the scheduled TDs. This interrupt cannot be disabled through the Interrupt Enable register.

5.19.7 USB Power Management

The Host controller can be put into a suspended state and its power can be removed. This requires that certain bits of information are retained in the resume power plane of the ICH6 so that a device on a port may wake the system. Such a device may be a fax-modem, which will wake up the machine to receive a fax or take a voice message. The settings of the following bits in I/O space will be maintained when the ICH6 enters the S3, S4, or S5 states.

Table 5-43. Bits Maintained in Low Power States

Register	Offset	Bit	Description
Command	00h	3	Enter Global Suspend Mode (EGSM)
Status	02h	2	Resume Detect
Port Status and Control	10h & 12h	2	Port Enabled/Disabled
		6	Resume Detect
		8	Low-speed Device Attached
		12	Suspend

When the ICH6 detects a resume event on any of its ports, it sets the corresponding USB_STS bit in ACPI space. If USB is enabled as a wake/break event, the system wakes up and an SCI generated.

5.19.8 USB Legacy Keyboard Operation

When a USB keyboard is plugged into the system, and a standard keyboard is not, the system may not boot, and MS-DOS legacy software will not run, because the keyboard will not be identified. The ICH6 implements a series of trapping operations which will snoop accesses that go to the keyboard controller, and put the expected data from the USB keyboard into the keyboard controller.

Note: The scheme described below assumes that the keyboard controller (8042 or equivalent) is on the LPC bus.

This legacy operation is performed through SMM space. Figure 5-9 shows the Enable and Status path. The latched SMI source (60R, 60W, 64R, 64W) is available in the Status Register. Because the enable is after the latch, it is possible to check for other events that didn't necessarily cause an SMI. It is the software's responsibility to logically AND the value with the appropriate enable bits.

Note also that the SMI is generated before the PCI cycle completes (e.g., before TRDY# goes active) to ensure that the processor doesn't complete the cycle before the SMI is observed. This method is used on MPIIX and has been validated.

The logic also needs to block the accesses to the 8042. If there is an external 8042, then this is simply accomplished by not activating the 8042 CS. This is simply done by logically ANDing the four enables (60R, 60W, 64R, 64W) with the 4 types of accesses to determine if 8042CS should go active. An additional term is required for the "pass-through" case.

The state table for Figure 5-9 is shown in Table 5-44.

Figure 5-9. USB Legacy Keyboard Flow Diagram

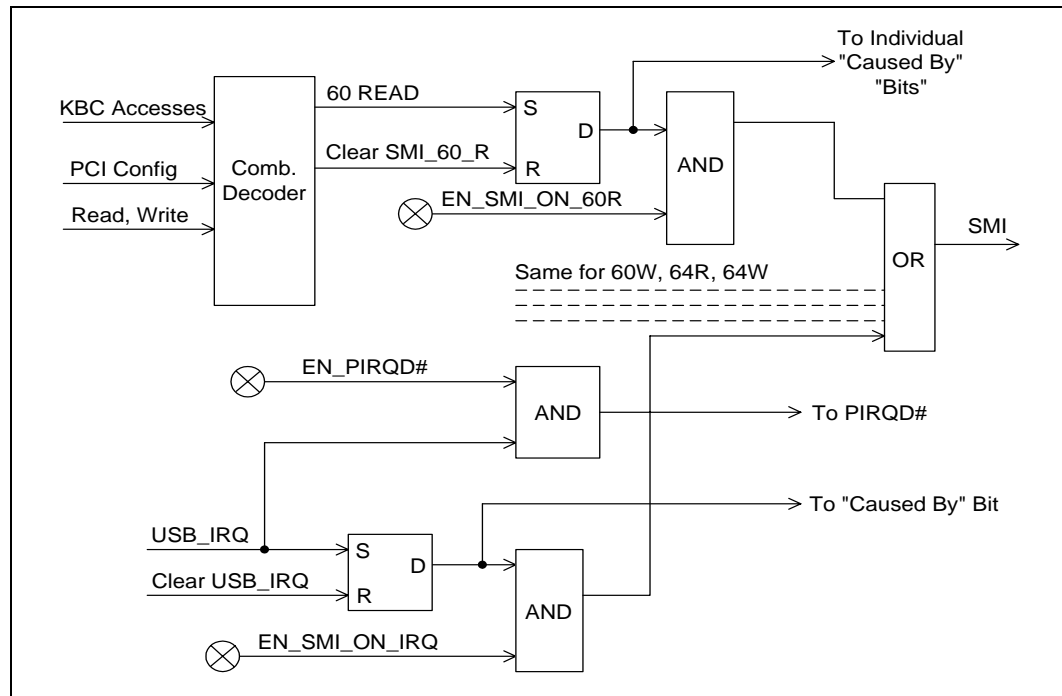

Table 5-44. USB Legacy Keyboard State Transitions

Current State	Action	Data Value	Next State	Comment
IDLE	64h / Write	D1h	GateState1	Standard D1 command. Cycle passed through to 8042. SMI# doesn't go active. PSTATE (offset C0, bit 6) goes to 1.
IDLE	64h / Write	Not D1h	IDLE	Bit 3 in Configuration Register determines if cycle passed through to 8042 and if SMI# generated.
IDLE	64h / Read	N/A	IDLE	Bit 2 in Configuration Register determines if cycle passed through to 8042 and if SMI# generated.
IDLE	60h / Write	Don't Care	IDLE	Bit 1 in Configuration Register determines if cycle passed through to 8042 and if SMI# generated.
IDLE	60h / Read	N/A	IDLE	Bit 0 in Configuration Register determines if cycle passed through to 8042 and if SMI# generated.
GateState1	60h / Write	XXh	GateState2	Cycle passed through to 8042, even if trap enabled in Bit 1 in Configuration Register. No SMI# generated. PSTATE remains 1. If data value is not DFh or DDh then the 8042 may chose to ignore it.
GateState1	64h / Write	D1h	GateState1	Cycle passed through to 8042, even if trap enabled via Bit 3 in Configuration Register. No SMI# generated. PSTATE remains 1. Stay in GateState1 because this is part of the double-trigger sequence.
GateState1	64h / Write	Not D1h	IDLE	Bit 3 in Configuration space determines if cycle passed through to 8042 and if SMI# generated. PSTATE goes to 0. If Bit 7 in Configuration Register is set, then SMI# should be generated.
GateState1	60h / Read	N/A	IDLE	This is an invalid sequence. Bit 0 in Configuration Register determines if cycle passed through to 8042 and if SMI# generated. PSTATE goes to 0. If Bit 7 in Configuration Register is set, then SMI# should be generated.
GateState1	64h / Read	N/A	GateState1	Just stay in same state. Generate an SMI# if enabled in Bit 2 of Configuration Register. PSTATE remains 1.
GateState2	64 / Write	FFh	IDLE	Standard end of sequence. Cycle passed through to 8042. PSTATE goes to 0. Bit 7 in Configuration Space determines if SMI# should be generated.
GateState2	64h / Write	Not FFh	IDLE	Improper end of sequence. Bit 3 in Configuration Register determines if cycle passed through to 8042 and if SMI# generated. PSTATE goes to 0. If Bit 7 in Configuration Register is set, then SMI# should be generated.
GateState2	64h / Read	N/A	GateState2	Just stay in same state. Generate an SMI# if enabled in Bit 2 of Configuration Register. PSTATE remains 1.
GateState2	60h / Write	XXh	IDLE	Improper end of sequence. Bit 1 in Configuration Register determines if cycle passed through to 8042 and if SMI# generated. PSTATE goes to 0. If Bit 7 in Configuration Register is set, then SMI# should be generated.
GateState2	60h / Read	N/A	IDLE	Improper end of sequence. Bit 0 in Configuration Register determines if cycle passed through to 8042 and if SMI# generated. PSTATE goes to 0. If Bit 7 in Configuration Register is set, then SMI# should be generated.

5.20 USB EHCI Host Controller (D29:F7)

The ICH6 contains an Enhanced Host Controller Interface (EHCI) compliant host controller which supports up to eight USB 2.0 high-speed compliant root ports. USB 2.0 allows data transfers up to 480 Mb/s using the same pins as the eight USB full-speed/low-speed ports. The ICH6 contains port-routing logic that determines whether a USB port is controlled by one of the UHCI controllers or by the EHCI controller. USB 2.0 based Debug Port is also implemented in the ICH6.

A summary of the key architectural differences between the USB UHCI host controllers and the EHCI host controller are shown in [Table 5-45](#).

Table 5-45. UHCI vs. EHCI

Parameter	USB UHCI	USB EHCI
Accessible by	I/O space	Memory Space
Memory Data Structure	Single linked list	Separated in to Periodic and Asynchronous lists
Differential Signaling Voltage	3.3 V	400 mV
Ports per Controller	2	8

5.20.1 EHC Initialization

The following descriptions step through the expected ICH6 Enhanced Host Controller (EHC) initialization sequence in chronological order, beginning with a complete power cycle in which the suspend well and core well have been off.

5.20.1.1 BIOS Initialization

BIOS performs a number of platform customization steps after the core well has powered up. Contact your Intel Field Representative for additional ICH6 BIOS information.

5.20.1.2 Driver Initialization

See Chapter 4 of the *Enhanced Host Controller Interface Specification for Universal Serial Bus, Revision 1.0*.

5.20.1.3 EHC Resets

In addition to the standard ICH6 hardware resets, portions of the EHC are reset by the HCRESET bit and the transition from the D3_{HOT} device power management state to the D0 state. The effects of each of these resets are shown in the following table:

Reset	Does Reset	Does not Reset	Comments
HCRESET bit set.	Memory space registers except Structural Parameters (which is written by BIOS).	Configuration registers.	The HCRESET must only affect registers that the EHCI driver controls. PCI Configuration space and BIOS-programmed parameters can not be reset.
Software writes the Device Power State from D3 _{HOT} (11b) to D0 (00b).	Core well registers (except BIOS-programmed registers).	Suspend well registers; BIOS-programmed core well registers.	The D3-to-D0 transition must not cause wake information (suspend well) to be lost. It also must not clear BIOS-programmed registers because BIOS may not be invoked following the D3-to-D0 transition.

If the detailed register descriptions give exceptions to these rules, those exceptions override these rules. This summary is provided to help explain the reasons for the reset policies.

5.20.2 Data Structures in Main Memory

See Section 3 and Appendix B of the *Enhanced Host Controller Interface Specification for Universal Serial Bus, Revision 1.0* for details.

5.20.3 USB 2.0 Enhanced Host Controller DMA

The ICH6 USB 2.0 EHC implements three sources of USB packets. They are, in order of priority on USB during each microframe:

1. The USB 2.0 Debug Port (see Section USB 2.0 Based Debug Port),
2. The Periodic DMA engine, and
3. The Asynchronous DMA engine. The ICH6 always performs any currently-pending debug port transaction at the beginning of a microframe, followed by any pending periodic traffic for the current microframe. If there is time left in the microframe, then the EHC performs any pending asynchronous traffic until the end of the microframe (EOF1). Note that the debug port traffic is only presented on one port (Port #0), while the other ports are idle during this time.

5.20.4 Data Encoding and Bit Stuffing

See Chapter 8 of the *Universal Serial Bus Specification, Revision 2.0*.

5.20.5 Packet Formats

See Chapter 8 of the *Universal Serial Bus Specification, Revision 2.0*.

The ICH6 EHCI allows entrance to USB test modes, as defined in the USB 2.0 specification, including Test J, Test Packet, etc. However note that the ICH6 Test Packet test mode interpacket gap timing may not meet the USB2.0 specification.

5.20.6 USB 2.0 Interrupts and Error Conditions

Section 4 of the *Enhanced Host Controller Interface Specification for Universal Serial Bus, Revision 1.0* goes into detail on the EHC interrupts and the error conditions that cause them. All error conditions that the EHC detects can be reported through the EHCI Interrupt status bits. Only ICH6-specific interrupt and error-reporting behavior is documented in this section. The EHCI Interrupts Section must be read first, followed by this section of the datasheet to fully comprehend the EHC interrupt and error-reporting functionality.

- Based on the EHC's Buffer sizes and buffer management policies, the Data Buffer Error can never occur on the ICH6.
- Master Abort and Target Abort responses from hub interface on EHC-initiated read packets will be treated as Fatal Host Errors. The EHC halts when these conditions are encountered.
- The ICH6 may assert the interrupts which are based on the interrupt threshold as soon as the status for the last complete transaction in the interrupt interval has been posted in the internal write buffers. The requirement in the *Enhanced Host Controller Interface Specification for Universal Serial Bus, Revision 1.0* (that the status is written to memory) is met internally, even though the write may not be seen on DMI before the interrupt is asserted.
- Since the ICH6 supports the 1024-element Frame List size, the Frame List Rollover interrupt occurs every 1024 milliseconds.
- The ICH6 delivers interrupts using PIRQ#.
- The ICH6 does not modify the CERR count on an Interrupt IN when the "Do Complete-Split" execution criteria are not met.
- For complete-split transactions in the Periodic list, the "Missed Microframe" bit does not get set on a control-structure-fetch that fails the late-start test. If subsequent accesses to that control structure do not fail the late-start test, then the "Missed Microframe" bit will get set and written back.

5.20.6.1 Aborts on USB 2.0-Initiated Memory Reads

If a read initiated by the EHC is aborted, the EHC treats it as a fatal host error. The following actions are taken when this occurs:

- The Host System Error status bit is set
- The DMA engines are halted after completing up to one more transaction on the USB interface
- If enabled (by the Host System Error Enable), then an interrupt is generated
- If the status is Master Abort, then the Received Master Abort bit in configuration space is set
- If the status is Target Abort, then the Received Target Abort bit in configuration space is set
- If enabled (by the SERR Enable bit in the function's configuration space), then the Signaled System Error bit in configuration bit is set.

5.20.7 USB 2.0 Power Management

5.20.7.1 Pause Feature

This feature allows platforms (especially mobile systems) to dynamically enter low-power states during brief periods when the system is idle (i.e., between keystrokes). This is useful for enabling power management features like Intel SpeedStep technology in the ICH6. The policies for entering these states typically are based on the recent history of system bus activity to incrementally enter deeper power management states. Normally, when the EHC is enabled, it regularly accesses main memory while traversing the DMA schedules looking for work to do; this activity is viewed by the power management software as a non-idle system, thus preventing the power managed states to be entered. Suspending all of the enabled ports can prevent the memory accesses from occurring, but there is an inherent latency overhead with entering and exiting the suspended state on the USB ports that makes this unacceptable for the purpose of dynamic power management. As a result, the EHCI software drivers are allowed to pause the EHC's DMA engines when it knows that the traffic patterns of the attached devices can afford the delay. The pause only prevents the EHC from generating memory accesses; the SOF packets continue to be generated on the USB ports (unlike the suspended state).

5.20.7.2 Suspend Feature

The *Enhanced Host Controller Interface (EHCI) For Universal Serial Bus Specification*, Section 4.3 describes the details of Port Suspend and Resume.

5.20.7.3 ACPI Device States

The USB 2.0 function only supports the D0 and D3 PCI Power Management states. Notes regarding the ICH6 implementation of the Device States:

1. The EHC hardware does not inherently consume any more power when it is in the D0 state than it does in the D3 state. However, software is required to suspend or disable all ports prior to entering the D3 state such that the maximum power consumption is reduced.
2. In the D0 state, all implemented EHC features are enabled.
3. In the D3 state, accesses to the EHC memory-mapped I/O range will master abort. Note that, since the Debug Port uses the same memory range, the Debug Port is only operational when the EHC is in the D0 state.
4. In the D3 state, the EHC interrupt must never assert for any reason. The internal PME# signal is used to signal wake events, etc.
5. When the Device Power State field is written to D0 from D3, an internal reset is generated. See section EHC Resets for general rules on the effects of this reset.
6. Attempts to write any other value into the Device Power State field other than 00b (D0 state) and 11b (D3 state) will complete normally without changing the current value in this field.

5.20.7.4 ACPI System States

The EHC behavior as it relates to other power management states in the system is summarized in the following list:

- The System is always in the S0 state when the EHC is in the D0 state. However, when the EHC is in the D3 state, the system may be in any power management state (including S0).
- When in D0, the Pause feature (See [Section 5.20.7.1](#)) enables dynamic processor low-power states to be entered.
- The PLL in the EHC is disabled when entering the S3_{HOT} state (48 MHz clock stops), or the S3_{COLD}/S4/S5 states (core power turns off).
- All core well logic is reset in the S3/S4/S5 states.

5.20.7.5 Mobile Considerations

The ICH6 USB 2.0 implementation does not behave differently in the mobile configurations versus the desktop configurations. However, some features may be especially useful for the mobile configurations.

- If a system (e.g., mobile) does not implement all eight USB 2.0 ports, the ICH6 provides mechanisms for changing the structural parameters of the EHC and hiding unused UHCI controllers. See ICH6 BIOS Specification on how BIOS should configure the ICH6.
- Mobile systems may want to minimize the conditions that will wake the system. The ICH6 implements the “Wake Enable” bits in the Port Status and Control registers, as specified in the EHCI spec, for this purpose.
- Mobile systems may want to cut suspend well power to some or all USB ports when in a low-power state. The ICH6 implements the optional Port Wake Capability Register in the EHC Configuration Space for this platform-specific information to be communicated to software.

5.20.8 Interaction with UHCI Host Controllers

The Enhanced Host controller shares the eight USB ports with four UHCI Host controllers in the ICH6. The UHC at D29:F0 shares ports 0 and 1; the UHC at D29:F1 shares ports 2 and 3; the UHC at D29:F2 shares ports 4 and 5; and the UHC at D29:F3 shares ports 6 and 7 with the EHC. There is very little interaction between the Enhanced and the UHCI controllers other than the multiplexing control which is provided as part of the EHC. [Figure 5-10](#) shows the USB Port Connections at a conceptual level.

5.20.8.1 Port-Routing Logic

Integrated into the EHC functionality is port-routing logic, that performs the multiplexing between the UHCI and EHCI host controllers. The ICH6 conceptually implements this logic as described in Section 4.2 of the *Enhanced Host Controller Interface Specification for Universal Serial Bus, Revision 1.0*. If a device is connected that is not capable of USB 2.0's high-speed signaling protocol or if the EHCI software drivers are not present as indicated by the Configured Flag, then the UHCI controller owns the port. Owning the port means that the differential output is driven by the owner and the input stream is only visible to the owner. The host controller that is not the owner of the port internally sees a disconnected port.

Figure 5-10. Intel® ICH6-USB Port Connections

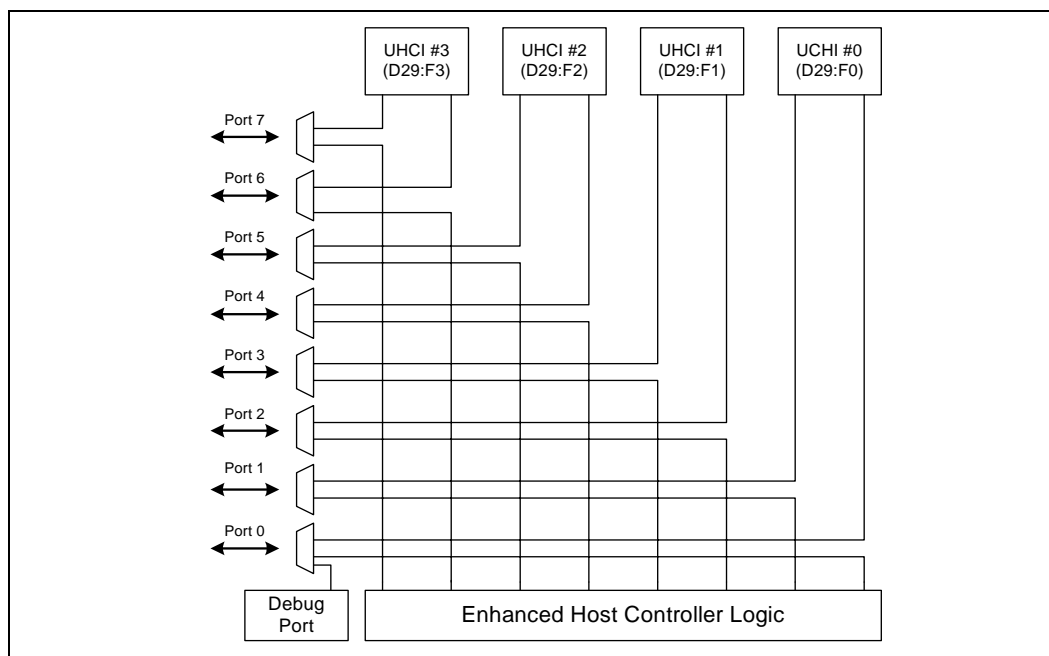

Note that the port-routing logic is the only block of logic within the ICH6 that observes the physical (real) connect/disconnect information. The port status logic inside each of the host controllers observes the electrical connect/disconnect information that is generated by the port-routing logic.

Only the differential signal pairs are multiplexed/demultiplexed between the UHCI and EHCI host controllers. The other USB functional signals are handled as follows:

- The Overcurrent inputs (OC[7:0]#) are directly routed to both controllers. An overcurrent event is recorded in both controllers' status registers.

The Port-Routing logic is implemented in the Suspend power well so that re-enumeration and re-mapping of the USB ports is not required following entering and exiting a system sleep state in which the core power is turned off.

The ICH6 also allows the USB Debug Port traffic to be routed in and out of Port #0. When in this mode, the Enhanced Host controller is the owner of Port #0.

5.20.8.2 Device Connects

The *Enhanced Host Controller Interface Specification for Universal Serial Bus, Revision 1.0* describes the details of handling Device Connects in Section 4.2. There are four general scenarios that are summarized below.

1. Configure Flag = 0 and a full-speed/low-speed-only Device is connected
 - In this case, the UHC is the owner of the port both before and after the connect occurs. The EHC (except for the port-routing logic) never sees the connect occur. The UHCI driver handles the connection and initialization process.
2. Configure Flag = 0 and a high-speed-capable Device is connected
 - In this case, the UHC is the owner of the port both before and after the connect occurs. The EHC (except for the port-routing logic) never sees the connect occur. The UHCI driver handles the connection and initialization process. Since the UHC does not perform the high-speed chirp handshake, the device operates in compatible mode.
3. Configure Flag = 1 and a full-speed/low-speed-only Device is connected
 - In this case, the EHC is the owner of the port before the connect occurs. The EHCI driver handles the connection and performs the port reset. After the reset process completes, the EHC hardware has cleared (not set) the Port Enable bit in the EHC's PORTSC register. The EHCI driver then writes a 1 to the Port Owner bit in the same register, causing the UHC to see a connect event and the EHC to see an "electrical" disconnect event. The UHCI driver and hardware handle the connection and initialization process from that point on. The EHCI driver and hardware handle the perceived disconnect.
4. Configure Flag = 1 and a high-speed-capable Device is connected
 - In this case, the EHC is the owner of the port before, and remains the owner after, the connect occurs. The EHCI driver handles the connection and performs the port reset. After the reset process completes, the EHC hardware has set the Port Enable bit in the EHC's PORTSC register. The port is functional at this point. The UHC continues to see an unconnected port.

5.20.8.3 Device Disconnects

The *Enhanced Host Controller Interface Specification for Universal Serial Bus, Revision 1.0* describes the details of handling Device Disconnects in Section 4.2. There are three general scenarios that are summarized below.

1. Configure Flag = 0 and the device is disconnected
 - In this case, the UHC is the owner of the port both before and after the disconnect occurs. The EHC (except for the port-routing logic) never sees a device attached. The UHCI driver handles disconnection process.
2. Configure Flag = 1 and a full-speed/low-speed-capable Device is disconnected
 - In this case, the UHC is the owner of the port before the disconnect occurs. The disconnect is reported by the UHC and serviced by the associated UHCI driver. The port-routing logic in the EHC cluster forces the Port Owner bit to 0, indicating that the EHC owns the unconnected port.
3. Configure Flag = 1 and a high-speed-capable Device is disconnected
 - In this case, the EHC is the owner of the port before, and remains the owner after, the disconnect occurs. The EHCI hardware and driver handle the disconnection process. The UHC never sees a device attached.

5.20.8.4 Effect of Resets on Port-Routing Logic

As mentioned above, the Port Routing logic is implemented in the suspend power well so that remuneration and re-mapping of the USB ports is not required following entering and exiting a system sleep state in which the core power is turned off.

Reset Event	Effect on Configure Flag	Effect on Port Owner Bits
Suspend Well Reset	cleared (0)	set (1)
Core Well Reset	no effect	no effect
D3-to-D0 Reset	no effect	no effect
HCRESET	cleared (0)	set (1)

5.20.9 USB 2.0 Legacy Keyboard Operation

The ICH6 must support the possibility of a keyboard downstream from either a full-speed/low-speed or a high-speed port. The description of the legacy keyboard support is unchanged from USB 1.1 (See [Section 5.19.8](#)).

The EHC provides the basic ability to generate SMIs on an interrupt event, along with more sophisticated control of the generation of SMIs.

5.20.10 USB 2.0 Based Debug Port

The ICH6 supports the elimination of the legacy COM ports by providing the ability for new debugger software to interact with devices on a USB 2.0 port.

High-level restrictions and features are:

- Operational before USB 2.0 drivers are loaded.
- Functions even when the port is disabled.
- Works even though non-configured port is default-routed to the UHCI. Note that the Debug Port can not be used to debug an issue that requires a full-speed/low-speed device on Port #0 using the UHCI drivers.
- Allows normal system USB 2.0 traffic in a system that may only have one USB port.
- Debug Port device (DPD) must be high-speed capable and connect directly to Port #0 on ICH6 systems (e.g., the DPD cannot be connected to Port #0 thru a hub).
- Debug Port FIFO always makes forward progress (a bad status on USB is simply presented back to software).
- The Debug Port FIFO is only given one USB access per microframe.

The Debug port facilitates operating system and device driver debug. It allows the software to communicate with an external console using a USB 2.0 connection. Because the interface to this link does not go through the normal USB 2.0 stack, it allows communication with the external console during cases where the operating system is not loaded, the USB 2.0 software is broken, or where the USB 2.0 software is being debugged. Specific features of this implementation of a debug port are:

- Only works with an external USB 2.0 debug device (console)
- Implemented for a specific port on the host controller
- Operational anytime the port is not suspended AND the host controller is in D0 power state.
- Capability is interrupted when port is driving USB RESET

5.20.10.1 Theory of Operation

There are two operational modes for the USB debug port:

1. Mode 1 is when the USB port is in a disabled state from the viewpoint of a standard host controller driver. In Mode 1, the Debug Port controller is required to generate a “keepalive” packets less than 2 ms apart to keep the attached debug device from suspending. The keepalive packet should be a standalone 32-bit SYNC field.
2. Mode 2 is when the host controller is running (i.e., host controller’s *Run/Stop#* bit is 1). In Mode 2, the normal transmission of SOF packets will keep the debug device from suspending.

Behavioral Rules

1. In both modes 1 and 2, the Debug Port controller must check for software requested debug transactions at least every 125 microseconds.
2. If the debug port is enabled by the debug driver, and the standard host controller driver resets the USB port, USB debug transactions are held off for the duration of the reset and until after the first SOF is sent.
3. If the standard host controller driver suspends the USB port, then USB debug transactions are held off for the duration of the suspend/resume sequence and until after the first SOF is sent.
4. The ENABLED_CNT bit in the debug register space is independent of the similar port control bit in the associated Port Status and Control register.

Table 5-46 shows the debug port behavior related to the state of bits in the debug registers as well as bits in the associated Port Status and Control register.

Table 5-46. Debug Port Behavior

OWNER_CNT	ENABLED_CT	Port Enable	Run / Stop	Suspend	Debug Port Behavior
0	X	X	X	X	Debug port is not being used. Normal operation.
1	0	X	X	X	Debug port is not being used. Normal operation.
1	1	0	0	X	Debug port in Mode 1. SYNC keepalives sent plus debug traffic
1	1	0	1	X	Debug port in Mode 2. SOF (and only SOF) is sent as keepalive. Debug traffic is also sent. Note that no other normal traffic is sent out this port, because the port is not enabled.
1	1	1	0	0	Illegal. Host controller driver should never put controller into this state (enabled, not running and not suspended).
1	1	1	0	1	Port is suspended. No debug traffic sent.
1	1	1	1	0	Debug port in Mode 2. Debug traffic is interspersed with normal traffic.
1	1	1	1	1	Port is suspended. No debug traffic sent.

5.20.10.1.1 OUT Transactions

An Out transaction sends data to the debug device. It can occur only when the following are true:

- The debug port is enabled
- The debug software sets the GO_CNT bit
- The WRITE_READ#_CNT bit is set

The sequence of the transaction is:

1. Software sets the appropriate values in the following bits:
 - USB_ADDRESS_CNF
 - USB_ENDPOINT_CNF
 - DATA_BUFFER[63:0]
 - TOKEN_PID_CNT[7:0]
 - SEND_PID_CNT[15:8]
 - DATA_LEN_CNT
 - WRITE_READ#_CNT (note: this will always be 1 for OUT transactions)
 - GO_CNT (note: this will always be 1 to initiate the transaction)

2. The debug port controller sends a token packet consisting of:
 - SYNC
 - TOKEN_PID_CNT field
 - USB_ADDRESS_CNT field
 - USB_ENDPOINT_CNT field
 - 5-bit CRC field
3. After sending the token packet, the debug port controller sends a data packet consisting of:
 - SYNC
 - SEND_PID_CNT field
 - The number of data bytes indicated in DATA_LEN_CNT from the DATA_BUFFER
 - 16-bit CRC

NOTE: A DATA_LEN_CNT value of 0 is valid in which case no data bytes would be included in the packet.

4. After sending the data packet, the controller waits for a handshake response from the debug device.
 - If a handshake is received, the debug port controller:
 - a. Places the received PID in the RECEIVED_PID_STS field
 - b. Resets the ERROR_GOOD#_STS bit
 - c. Sets the DONE_STS bit
 - If no handshake PID is received, the debug port controller:
 - a. Sets the EXCEPTION_STS field to 001b
 - b. Sets the ERROR_GOOD#_STS bit
 - c. Sets the DONE_STS bit

5.20.10.1.2 IN Transactions

An IN transaction receives data from the debug device. It can occur only when the following are true:

- The debug port is enabled
- The debug software sets the GO_CNT bit
- The WRITE_READ#_CNT bit is reset

The sequence of the transaction is:

1. Software sets the appropriate values in the following bits:
 - USB_ADDRESS_CNF
 - USB_ENDPOINT_CNF
 - TOKEN_PID_CNT[7:0]
 - DATA_LEN_CNT
 - WRITE_READ#_CNT (note: this will always be 0 for IN transactions)
 - GO_CNT (note: this will always be 1 to initiate the transaction)

2. The debug port controller sends a token packet consisting of:
 - SYNC
 - TOKEN_PID_CNT field
 - USB_ADDRESS_CNT field
 - USB_ENDPOINT_CNT field
 - 5-bit CRC field.
3. After sending the token packet, the debug port controller waits for a response from the debug device.
If a response is received:
 - The received PID is placed into the RECEIVED_PID_STS field
 - Any subsequent bytes are placed into the DATA_BUFFER
 - The DATA_LEN_CNT field is updated to show the number of bytes that were received after the PID.
4. If valid packet was received from the device that was one byte in length (indicating it was a handshake packet), then the debug port controller:
 - Resets the ERROR_GOOD#_STS bit
 - Sets the DONE_STS bit
5. If valid packet was received from the device that was more than one byte in length (indicating it was a data packet), then the debug port controller:
 - Transmits an ACK handshake packet
 - Resets the ERROR_GOOD#_STS bit
 - Sets the DONE_STS bit
6. If no valid packet is received, then the debug port controller:
 - Sets the EXCEPTION_STS field to 001b
 - Sets the ERROR_GOOD#_STS bit
 - Sets the DONE_STS bit.

5.20.10.1.3 Debug Software

Enabling the Debug Port

There are two mutually exclusive conditions that debug software must address as part of its startup processing:

- The EHCI has been initialized by system software
- The EHCI has not been initialized by system software

Debug software can determine the current ‘initialized’ state of the EHCI by examining the Configure Flag in the EHCI USB 2.0 Command Register. If this flag is set, then system software has initialized the EHCI. Otherwise the EHCI should not be considered initialized. Debug software will initialize the debug port registers depending on the state the EHCI. However, before this can be accomplished, debug software must determine which root USB port is designated as the debug port.

Determining the Debug Port

Debug software can easily determine which USB root port has been designated as the debug port by examining bits 20:23 of the EHCI Host Controller Structural Parameters register. This 4-bit field represents the numeric value assigned to the debug port (i.e., 0000=port 0).

Debug Software Startup with Non-Initialized EHCI

Debug software can attempt to use the debug port if after setting the OWNER_CNT bit, the Current Connect Status bit in the appropriate (See Determining the Debug Port) PORTSC register is set. If the Current Connect Status bit is not set, then debug software may choose to terminate or it may choose to wait until a device is connected.

If a device is connected to the port, then debug software must reset/enable the port. Debug software does this by setting and then clearing the Port Reset bit the PORTSC register. To guarantee a successful reset, debug software should wait at least 50 ms before clearing the Port Reset bit. Due to possible delays, this bit may not change to 0 immediately; reset is complete when this bit reads as 0. Software must not continue until this bit reads 0.

If a high-speed device is attached, the EHCI will automatically set the Port Enabled/Disabled bit in the PORTSC register and the debug software can proceed. Debug software should set the ENABLED_CNT bit in the Debug Port Control/Status register, and then reset (clear) the Port Enabled/Disabled bit in the PORTSC register (so that the system host controller driver does not see an enabled port when it is first loaded).

Debug Software Startup with Initialized EHCI

Debug software can attempt to use the debug port if the Current Connect Status bit in the appropriate (See Determining the Debug Port) PORTSC register is set. If the Current Connect Status bit is not set, then debug software may choose to terminate or it may choose to wait until a device is connected.

If a device is connected, then debug software must set the OWNER_CNT bit and then the ENABLED_CNT bit in the Debug Port Control/Status register.

Determining Debug Peripheral Presence

After enabling the debug port functionality, debug software can determine if a debug peripheral is attached by attempting to send data to the debug peripheral. If all attempts result in an error (Exception bits in the Debug Port Control/Status register indicates a Transaction Error), then the attached device is not a debug peripheral. If the debug port peripheral is not present, then debug software may choose to terminate or it may choose to wait until a debug peripheral is connected.

5.21 SMBus Controller (D31:F3)

The ICH6 provides a System Management Bus (SMBus) 2.0 compliant host controller as well as a SMBus slave interface. The host controller provides a mechanism for the processor to initiate communications with SMBus peripherals (slaves). The ICH6 is also capable of operating in a mode in which it can communicate with I²C compatible devices.

The ICH6 can perform SMBus messages with either packet error checking (PEC) enabled or disabled. The actual PEC calculation and checking is performed in hardware by the ICH6.

The Slave Interface allows an external master to read from or write to the ICH6. Write cycles can be used to cause certain events or pass messages, and the read cycles can be used to determine the state of various status bits. The ICH6's internal host controller cannot access the ICH6's internal Slave Interface.

The ICH6 SMBus logic exists in Device 31:Function 3 configuration space, and consists of a transmit data path, and host controller. The transmit data path provides the data flow logic needed to implement the seven different SMBus command protocols and is controlled by the host controller. The ICH6 SMBus controller logic is clocked by RTC clock.

The SMBus Address Resolution Protocol (ARP) is supported by using the existing host controller commands through software, except for the new Host Notify command (which is actually a received message).

The programming model of the host controller is combined into two portions: a PCI configuration portion, and a system I/O mapped portion. All static configuration, such as the I/O base address, is done via the PCI configuration space. Real-time programming of the Host interface is done in system I/O space.

The ICH6 SMBus host controller checks for parity errors as a target. If an error is detected, the detected parity error bit in the PCI Status Register (Device 31:Function 3:Offset 06h:bit 15) is set. If bit 6 and bit 8 of the PCI Command Register (Device 31:Function 3:Offset 04h) are set, an SERR# is generated and the signaled SERR# bit in the PCI Status Register (bit 14) is set.

Unless otherwise specified, all of the SMBus logic and its registers are reset by either RSMRST# or a similar reset via CF9h.

5.21.1 Host Controller

The SMBus host controller is used to send commands to other SMBus slave devices. Software sets up the host controller with an address, command, and, for writes, data and optional PEC; and then tells the controller to start. When the controller has finished transmitting data on writes, or receiving data on reads, it generates an SMI# or interrupt, if enabled.

The host controller supports eight command protocols of the SMBus interface (see *System Management Bus (SMBus) Specification, Version 2.0*): Quick Command, Send Byte, Receive Byte, Write Byte/Word, Read Byte/Word, Process Call, Block Read/Write, Block Write–Block Read Process Call, and Host Notify.

The SMBus host controller requires that the various data and command fields be setup for the type of command to be sent. When software sets the START bit, the SMBus Host controller performs the requested transaction, and interrupts the processor (or generates an SMI#) when the transaction is completed. Once a START command has been issued, the values of the “active registers” (Host Control, Host Command, Transmit Slave Address, Data 0, Data 1) should not be changed or read

until the interrupt status bit (INTR) has been set (indicating the completion of the command). Any register values needed for computation purposes should be saved prior to issuing of a new command, as the SMBus host controller updates all registers while completing the new command.

Using the SMB host controller to send commands to the ICH6's SMB slave port is supported. The ICH6 is fully compliant with the *System Management Bus (SMBus) Specification, Version 2.0*. Slave functionality, including the Host Notify protocol, is available on the SMBus pins. The SMLink and SMBus signals should not be tied together externally.

5.21.1.1 Command Protocols

In all of the following commands, a Host Status Register is used to determine the progress of the command. While the command is in operation, the HOST_BUSY bit is set. If the command completes successfully, the INTR bit will be set in the Host Status Register. If the device does not respond with an acknowledge, and the transaction times out, the DEV_ERR bit is set. If software sets the KILL bit in the Host Control Register while the command is running, the transaction will stop and the FAILED bit will be set.

Quick Command

When programmed for a Quick Command, the Transmit Slave Address Register is sent. The PEC byte is never appended to the Quick Protocol. Software should force the PEC_EN bit to 0 when performing the Quick Command. Software must force the I2C_EN bit to 0 when running this command. See section 5.5.1 of the *System Management Bus (SMBus) Specification, Version 2.0* for the format of the protocol.

Send Byte / Receive Byte

For the Send Byte command, the Transmit Slave Address and Device Command Registers are sent. For the Receive Byte command, the Transmit Slave Address Register is sent. The data received is stored in the DATA0 register. Software must force the I2C_EN bit to 0 when running this command.

The Receive Byte is similar to a Send Byte, the only difference is the direction of data transfer. See sections 5.5.2 and 5.5.3 of the *System Management Bus (SMBus) Specification, Version 2.0* for the format of the protocol.

Write Byte/Word

The first byte of a Write Byte/Word access is the command code. The next 1 or 2 bytes are the data to be written. When programmed for a Write Byte/Word command, the Transmit Slave Address, Device Command, and Data0 Registers are sent. In addition, the Data1 Register is sent on a Write Word command. Software must force the I2C_EN bit to 0 when running this command. See section 5.5.4 of the *System Management Bus (SMBus) Specification, Version 2.0* for the format of the protocol.

Read Byte/Word

Reading data is slightly more complicated than writing data. First the ICH6 must write a command to the slave device. Then it must follow that command with a repeated start condition to denote a read from that device's address. The slave then returns 1 or 2 bytes of data. Software must force the I2C_EN bit to 0 when running this command.

When programmed for the read byte/word command, the Transmit Slave Address and Device Command Registers are sent. Data is received into the DATA0 on the read byte, and the DAT0 and DATA1 registers on the read word. See section 5.5.5 of the *System Management Bus (SMBus) Specification, Version 2.0* for the format of the protocol.

Process Call

The process call is so named because a command sends data and waits for the slave to return a value dependent on that data. The protocol is simply a Write Word followed by a Read Word, but without a second command or stop condition.

When programmed for the Process Call command, the ICH6 transmits the Transmit Slave Address, Host Command, DATA0 and DATA1 registers. Data received from the device is stored in the DATA0 and DATA1 registers. The Process Call command with I2C_EN set and the PEC_EN bit set produces undefined results. Software must force either I2C_EN or PEC_EN to 0 when running this command. See section 5.5.6 of the *System Management Bus (SMBus) Specification, Version 2.0* for the format of the protocol.

Note: For process call command, the value written into bit 0 of the Transmit Slave Address Register (SMB I/O register, offset 04h) needs to be 0.

Note: If the I2C_EN bit is set, the protocol sequence changes slightly: the Command Code (bits 18:11 in the bit sequence) are not sent - as a result, the slave will not acknowledge (bit 19 in the sequence).

Block Read/Write

The ICH6 contains a 32-byte buffer for read and write data that can be enabled by setting bit 1 of the Auxiliary Control register at offset 0Dh in I/O space, as opposed to a single byte of buffering. This 32-byte buffer is filled with write data before transmission, and filled with read data on reception. In the ICH6, the interrupt is generated only after a transmission or reception of 32 bytes, or when the entire byte count has been transmitted/received.

The byte count field is transmitted but ignored by the ICH6 as software will end the transfer after all bytes it cares about have been sent or received.

For a Block Write, software must either force the I2C_EN bit or both the PEC_EN and AAC bits to 0 when running this command.

The block write begins with a slave address and a write condition. After the command code the ICH6 issues a byte count describing how many more bytes will follow in the message. If a slave had 20 bytes to send, the first byte would be the number 20 (14h), followed by 20 bytes of data. The byte count may not be 0. A Block Read or Write is allowed to transfer a maximum of 32 data bytes.

When programmed for a block write command, the Transmit Slave Address, Device Command, and Data0 (count) registers are sent. Data is then sent from the Block Data Byte register; the total data sent being the value stored in the Data0 Register. On block read commands, the first byte received is stored in the Data0 register, and the remaining bytes are stored in the Block Data Byte register. See section 5.5.7 of the *System Management Bus (SMBus) Specification, Version 2.0* for the format of the protocol.

Note: For Block Write, if the I2C_EN bit is set, the format of the command changes slightly. The ICH6 will still send the number of bytes (on writes) or receive the number of bytes (on reads) indicated in the DATA0 register. However, it will not send the contents of the DATA0 register as part of the

message. Also, the Block Write protocol sequence changes slightly: the Byte Count (bits 27:20 in the bit sequence) are not sent - as a result, the slave will not acknowledge (bit 28 in the sequence).

I²C Read

This command allows the ICH6 to perform block reads to certain I²C devices, such as serial E²PROMs. The SMBus Block Read supports the 7-bit addressing mode only.

However, this does not allow access to devices using the I²C “Combined Format” that has data bytes after the address. Typically these data bytes correspond to an offset (address) within the serial memory chips.

Note: This command is supported independent of the setting of the I2C_EN bit. The I²C Read command with the PEC_EN bit set produces undefined results. Software must force both the PEC_EN and AAC bit to 0 when running this command.

For I²C Read command, the value written into bit 0 of the Transmit Slave Address Register (SMB I/O register, offset 04h) needs to be 0.

The format that is used for the command is shown in [Table 5-47](#).

Table 5-47. I²C Block Read

Bit	Description
1	Start
8:2	Slave Address — 7 bits
9	Write
10	Acknowledge from slave
18:11	Send DATA1 register
19	Acknowledge from slave
20	Repeated Start
27:21	Slave Address — 7 bits
28	Read
29	Acknowledge from slave
37:30	Data byte 1 from slave — 8 bits
38	Acknowledge
46:39	Data byte 2 from slave — 8 bits
47	Acknowledge
–	Data bytes from slave / Acknowledge
–	Data byte N from slave — 8 bits
–	NOT Acknowledge
–	Stop

The ICH6 will continue reading data from the peripheral until the NAK is received.

Block Write–Block Read Process Call

The block write-block read process call is a two-part message. The call begins with a slave address and a write condition. After the command code the host issues a write byte count (M) that describes how many more bytes will be written in the first part of the message. If a master has 6 bytes to send, the byte count field will have the value 6 (0000 0110b), followed by the 6 bytes of data. The write byte count (M) cannot be 0.

The second part of the message is a block of read data beginning with a repeated start condition followed by the slave address and a Read bit. The next byte is the read byte count (N), which may differ from the write byte count (M). The read byte count (N) cannot be 0.

The combined data payload must not exceed 32 bytes. The byte length restrictions of this process call are summarized as follows:

- $M \geq 1$ byte
- $N \geq 1$ byte
- $M + N \leq 32$ bytes

The read byte count does not include the PEC byte. The PEC is computed on the total message beginning with the first slave address and using the normal PEC computational rules. It is highly recommended that a PEC byte be used with the Block Write-Block Read Process Call. Software must do a read to the command register (offset 2h) to reset the 32 byte buffer pointer prior to reading the block data register.

Note that there is no STOP condition before the repeated START condition, and that a NACK signifies the end of the read transfer.

Note: E32B bit in the Auxiliary Control register must be set when using this protocol.

See section 5.5.8 of the *System Management Bus (SMBus) Specification, Version 2.0* for the format of the protocol.

5.21.2 Bus Arbitration

Several masters may attempt to get on the bus at the same time by driving the SMBDATA line low to signal a start condition. The ICH6 continuously monitors the SMBDATA line. When the ICH6 is attempting to drive the bus to a 1 by letting go of the SMBDATA line, and it samples SMBDATA low, then some other master is driving the bus and the ICH6 will stop transferring data.

If the ICH6 sees that it has lost arbitration, the condition is called a collision. The ICH6 will set the BUS_ERR bit in the Host Status Register, and if enabled, generate an interrupt or SMI#. The processor is responsible for restarting the transaction.

When the ICH6 is a SMBus master, it drives the clock. When the ICH6 is sending address or command as an SMBus master, or data bytes as a master on writes, it drives data relative to the clock it is also driving. It will not start toggling the clock until the start or stop condition meets proper setup and hold time. The ICH6 will also guarantee minimum time between SMBus transactions as a master.

Note: The ICH6 supports the same arbitration protocol for both the SMBus and the System Management (SMLINK) interfaces.

5.21.3 Bus Timing

5.21.3.1 Clock Stretching

Some devices may not be able to handle their clock toggling at the rate that the ICH6 as an SMBus master would like. They have the capability of stretching the low time of the clock. When the ICH6 attempts to release the clock (allowing the clock to go high), the clock will remain low for an extended period of time.

The ICH6 monitors the SMBus clock line after it releases the bus to determine whether to enable the counter for the high time of the clock. While the bus is still low, the high time counter must not be enabled. Similarly, the low period of the clock can be stretched by an SMBus master if it is not ready to send or receive data.

5.21.3.2 Bus Time Out (Intel® ICH6 as SMBus Master)

If there is an error in the transaction, such that an SMBus device does not signal an acknowledge, or holds the clock lower than the allowed time-out time, the transaction will time out. The ICH6 will discard the cycle and set the DEV_ERR bit. The time out minimum is 25 ms (800 RTC clocks). The time-out counter inside the ICH6 will start after the last bit of data is transferred by the ICH6 and it is waiting for a response.

The 25 ms timeout counter will not count under the following conditions:

1. BYTE_DONE_STATUS bit (SMBus I/O Offset 00h, bit 7) is set
2. The SECOND_TO_STS bit (TCO I/O Offset 06h, bit 1) is not set (this indicates that the system has not locked up)

5.21.4 Interrupts / SMI#

The ICH6 SMBus controller uses PIRQB# as its interrupt pin. However, the system can alternatively be set up to generate SMI# instead of an interrupt, by setting the SMBus_SMI_EN bit (Device 31:Function 0:Offset 40h:bit 1).

Table 5-49 and Table 5-50 specify how the various enable bits in the SMBus function control the generation of the interrupt, Host and Slave SMI, and Wake internal signals. The rows in the tables are additive, which means that if more than one row is true for a particular scenario then the Results for all of the activated rows will occur.

Table 5-48. Enable for SMBALERT#

Event	INTREN (Host Control I/O Register, Offset 02h, Bit 0)	SMB_SMI_EN (Host Configuration Register, D31:F3:Offset 40h, Bit 1)	SMBALERT_DIS (Slave Command I/O Register, Offset 11h, Bit 2)	Result
SMBALERT# asserted low (always reported in Host Status Register, Bit 5)	X	X	X	Wake generated
	X	1	0	Slave SMI# generated (SMBus_SMI_STS)
	1	0	0	Interrupt generated

Table 5-49. Enables for SMBus Slave Write and SMBus Host Events

Event	INTREN (Host Control I/O Register, Offset 02h, Bit 0)	SMB_SMI_EN (Host Configuration Register, D31:F3:Offset 40h, Bit1)	Event
Slave Write to Wake/ SMI# Command	X	X	Wake generated when asleep. Slave SMI# generated when awake (SMBus_SMI_STS).
Slave Write to SMLINK_SLAVE_SMI Command	X	X	Slave SMI# generated when in the S0 state (SMBus_SMI_STS)
Any combination of Host Status Register [4:1] asserted	0	X	None
	1	0	Interrupt generated
	1	1	Host SMI# generated

Table 5-50. Enables for the Host Notify Command

HOST_NOTIFY_INTREN (Slave Control I/O Register, Offset 11h, bit 0)	SMB_SMI_EN (Host Configuration Register, D31:F3:Off40h, Bit 1)	HOST_NOTIFY_WKEN (Slave Control I/O Register, Offset 11h, bit 1)	Result
0	X	0	None
X	X	1	Wake generated
1	0	X	Interrupt generated
1	1	X	Slave SMI# generated (SMBus_SMI_STS)

5.21.5 SMBALERT#

SMBALERT# is multiplexed with GPI[11]. When enable and the signal is asserted, The ICH6 can generate an interrupt, an SMI#, or a wake event from S1–S5.

Note: Any event on SMBALERT# (regardless whether it is programmed as a GPI or not), causes the event message to be sent in heartbeat mode.

5.21.6 SMBus CRC Generation and Checking

If the AAC bit is set in the Auxiliary Control register, the ICH6 automatically calculates and drives CRC at the end of the transmitted packet for write cycles, and will check the CRC for read cycles. It will not transmit the contents of the PEC register for CRC. The PEC bit must not be set in the Host Control register if this bit is set, or unspecified behavior will result.

If the read cycle results in a CRC error, the DEV_ERR bit and the CRCE bit in the Auxiliary Status register at offset 0Ch will be set.

5.21.7 SMBus Slave Interface

The ICH6's SMBus slave interface is accessed via the SMBus. The SMBus slave logic will not generate or handle receiving the PEC byte and will only act as a Legacy Alerting Protocol device. The slave interface allows the ICH6 to decode cycles, and allows an external microcontroller to perform specific actions. Key features and capabilities include:

- Supports decode of three types of messages: Byte Write, Byte Read, and Host Notify.
- Receive Slave Address register: This is the address that the ICH6 decodes. A default value is provided so that the slave interface can be used without the processor having to program this register.
- Receive Slave Data register in the SMBus I/O space that includes the data written by the external microcontroller.
- Registers that the external microcontroller can read to get the state of the ICH6.
- Status bits to indicate that the SMBus slave logic caused an interrupt or SMI# due to the reception of a message that matched the slave address.
 - Bit 0 of the Slave Status Register for the Host Notify command
 - Bit 16 of the SMI Status Register (Section 10.8.3.13) for all others

If a master leaves the clock and data bits of the SMBus interface at 1 for 50 μ s or more in the middle of a cycle, the ICH6 slave logic's behavior is undefined. This is interpreted as an unexpected idle and should be avoided when performing management activities to the slave logic.

Note: When an external microcontroller accesses the SMBus slave interface over the SMBus a translation in the address is needed to accommodate the least significant bit used for read/write control. For example, if the ICH6 slave address (RCV_SLVA) is left at 44h (default), the external micro controller would use an address of 88h/89h (write/read).

5.21.7.1 Format of Slave Write Cycle

The external master performs Byte Write commands to the ICH6 SMBus slave interface. The “Command” field (bits 11:18) indicate which register is being accessed. The Data field (bits 20:27) indicate the value that should be written to that register. [Table 5-51](#) has the values associated with the registers.

Table 5-51. Slave Write Registers

Register	Function
0	Command Register. See Table 5-52 below for legal values written to this register.
1–3	Reserved
4	Data Message Byte 0
5	Data Message Byte 1
6–7	Reserved
8	Reserved
9–FFh	Reserved

NOTE: The external microcontroller is responsible to make sure that it does not update the contents of the data byte registers until they have been read by the system processor. The ICH6 overwrites the old value with any new value received. A race condition is possible where the new value is being written to the register just at the time it is being read. ICH6 will not attempt to cover this race condition (i.e., unpredictable results in this case).

Table 5-52. Command Types (Sheet 1 of 2)

Command Type	Description
0	Reserved
1	WAKE/SMI#. This command wakes the system if it is not already awake. If system is already awake, an SMI# is generated. NOTE: The SMB_WAK_STS bit will be set by this command, even if the system is already awake. The SMI handler should then clear this bit.
2	Unconditional Powerdown. This command sets the PWRBTNOR_STS bit, and has the same effect as the Powerbutton Override occurring.
3	HARD RESET WITHOUT CYCLING: This command causes a hard reset of the system (does not include cycling of the power supply). This is equivalent to a write to the CF9h register with bits 2:1 set to 1, but bit 3 set to 0.
4	HARD RESET SYSTEM. This command causes a hard reset of the system (including cycling of the power supply). This is equivalent to a write to the CF9h register with bits 3:1 set to 1.
5	Disable the TCO Messages. This command will disable the Intel® ICH6 from sending Heartbeat and Event messages (as described in Section 5.15.2). Once this command has been executed, Heartbeat and Event message reporting can only be re-enabled by assertion and de-assertion of the RSMRST# signal.
6	WD RELOAD: Reload watchdog timer.
7	Reserved

Table 5-52. Command Types (Sheet 2 of 2)

Command Type	Description
8	<p>SMLINK_SLV_SMI. When ICH6 detects this command type while in the S0 state, it sets the SMLINK_SLV_SMI_STS bit (see Section 10.9.5). This command should only be used if the system is in an S0 state. If the message is received during S1–S5 states, the ICH6 acknowledges it, but the SMLINK_SLV_SMI_STS bit does not get set.</p> <p>NOTE: It is possible that the system transitions out of the S0 state at the same time that the SMLINK_SLV_SMI command is received. In this case, the SMLINK_SLV_SMI_STS bit may get set but not serviced before the system goes to sleep. Once the system returns to S0, the SMI associated with this bit would then be generated. Software must be able to handle this scenario.</p>
9–FFh	Reserved

5.21.7.2 Format of Read Command

The external master performs Byte Read commands to the ICH6 SMBus Slave I/F. The “Command” field (bits 18:11) indicate which register is being accessed. The Data field (bits 30:37) contain the value that should be read from that register. [Table 5-53](#) shows the Read Cycle Format. [Table 5-54](#) shows the register mapping for the data byte.

Table 5-53. Read Cycle Format

Bit	Description	Driven by	Comment
1	Start	External Microcontroller	
8:2	Slave Address - 7 bits	External Microcontroller	Must match value in Receive Slave Address register
9	Write	External Microcontroller	Always 0
10	ACK	Intel® ICH6	
18:11	Command code - 8 bits	External Microcontroller	Indicates which register is being accessed See Table 5-54
19	ACK	ICH6	
20	Repeated Start	External Microcontroller	
27:21	Slave Address - 7 bits	External Microcontroller	Must match value in Receive Slave Address register
28	Read	External Microcontroller	Always 1
29	ACK	ICH6	
37:30	Data Byte	ICH6	Value depends on register being accessed. See Table 5-54
38	NOT ACK	External Microcontroller	
39	Stop	External Microcontroller	

Table 5-54. Data Values for Slave Read Registers

Register	Bits	Description
0	7:0	Reserved
1	2:0	System Power State 000 = S0 001 = S1 010 = Reserved 011 = S3 100 = S4 101 = S5 110 = Reserved 111 = Reserved
1	7:3	Reserved
2	3:0	Frequency Strap Register
2	7:4	Reserved
3	5:0	Watchdog Timer current value
3	7:6	Reserved
4	0	1 = The Intruder Detect (INTRD_DET) bit is set. This indicates that the system cover has probably been opened.
4	1	1 = BTI Temperature Event occurred. This bit will be set if the Intel® ICH6's THRM# input signal is active. Need to take after polarity control.
4	2	Boot-status. This bit will be 1 when the processor does not fetch the first instruction.
4	3	This bit will be set after the TCO timer times out a second time (Both TIMEOUT and SECOND_TO_STS bits set).
4	6:4	Reserved
4	7	The bit will reflect the state of the GPI11/SMBALERT# signal, and will depend on the GP_INV11 bit. It does not matter if the pin is configured as GPI11 or SMBALERT#. <ul style="list-style-type: none"> If the GP_INV11 bit is 1, the value of register 4 bit 7 will equal the level of the GPI11/SMBALERT# pin (high = 1, low = 0). If the GP_INV11 bit is 0, the value of register 4 bit 7 will equal the inverse of the level of the GPI11/SMBALERT# pin (high = 1, low = 0).
5	0	Unprogrammed flash BIOS bit. This bit will be 1 to indicate that the first BIOS fetch returned FFh, that indicates that the flash BIOS is probably blank.
5	1	Reserved
5	2	Processor Power Failure Status. 1 if the CPUPWR_FLR bit in the GEN_PMCON_2 register is set.
5	7:3	Reserved
6	7:0	Contents of the Message 1 register.
7	7:0	Contents of the Message 2 register.
8	7:0	Contents of the WDSTATUS register.
9-FFh	7:0	Reserved

5.21.7.2.1 Behavioral Notes

According to SMBus protocol, Read and Write messages always begin with a Start bit – Address–Write bit sequence. When the ICH6 detects that the address matches the value in the Receive Slave Address register, it will assume that the protocol is always followed and ignore the Write bit (bit 9) and signal an Acknowledge during bit 10. In other words, if a Start –Address–Read occurs (which is illegal for SMBus Read or Write protocol), and the address matches the ICH6’s Slave Address, the ICH6 will still grab the cycle.

Also according to SMBus protocol, a Read cycle contains a Repeated Start–Address–Read sequence beginning at bit 20. Once again, if the Address matches the ICH6’s Receive Slave Address, it will assume that the protocol is followed, ignore bit 28, and proceed with the Slave Read cycle.

Note: An external microcontroller must not attempt to access the ICH6’s SMBus Slave logic until at least 1 second after both RTCRST# and RSMRST# are de-asserted (high).

5.21.7.3 Format of Host Notify Command

The ICH6 tracks and responds to the standard Host Notify command as specified in the *System Management Bus (SMBus) Specification, Version 2.0*. The host address for this command is fixed to 0001000b. If the ICH6 already has data for a previously-received host notify command that has not been serviced yet by the host software (as indicated by the HOST_NOTIFY_STS bit), then it will NACK following the host address byte of the protocol. This allows the host to communicate non-acceptance to the master and retain the host notify address and data values for the previous cycle until host software completely services the interrupt.

Note: Host software must always clear the HOST_NOTIFY_STS bit after completing any necessary reads of the address and data registers.

Table 5-55 shows the Host Notify format.

Table 5-55. Host Notify Format

Bit	Description	Driven By	Comment
1	Start	External Master	
8:2	SMB Host Address — 7 bits	External Master	Always 0001_000
9	Write	External Master	Always 0
10	ACK (or NACK)	Intel® ICH6	ICH6 NACKs if HOST_NOTIFY_STS is 1
17:11	Device Address – 7 bits	External Master	Indicates the address of the master; loaded into the Notify Device Address Register
18	Unused — Always 0	External Master	7-bit-only address; this bit is inserted to complete the byte
19	ACK	ICH6	
27:20	Data Byte Low — 8 bits	External Master	Loaded into the Notify Data Low Byte Register
28	ACK	ICH6	
36:29	Data Byte High — 8 bits	External Master	Loaded into the Notify Data High Byte Register
37	ACK	ICH6	
38	Stop	External Master	

5.22 AC '97 Controller (Audio D30:F2, Modem D30:F3)

Note: All references to AC '97 in this document refer to the *AC '97 Specification, Version 2.3*. For further information on the operation of the AC-link protocol, see the *AC '97 Specification, Version 2.3*.

The ICH6 AC '97 controller features include:

- Independent PCI functions for audio and modem.
- Independent bus master logic for dual Microphone input, dual PCM Audio input (2-channel stereo per input), PCM audio output (2-, 4- or 6-channel audio), Modem input, Modem output and S/PDIF output.
- 20-bit sample resolution
- Multiple sample rates up to 48 kHz
- Support for 16 codec-implemented GPIOs
- Single modem line
- Configure up to three codecs with three ACZ_SDIN pins

Table 5-56 shows a detailed list of features supported by the ICH6 AC '97 digital controller.

Table 5-56. Features Supported by Intel® ICH6 (Sheet 1 of 2)

Feature	Description
System Interface	<ul style="list-style-type: none"> • Isochronous low latency bus master memory interface • Scatter/gather support for word-aligned buffers in memory (all mono or stereo 20-bit and 16-bit data types are supported, no 8-bit data types are supported) • Data buffer size in system memory from 3 to 65535 samples per input • Data buffer size in system memory from 0 to 65535 samples per output • Independent PCI audio and modem functions with configuration and I/O spaces • AC '97 codec registers are shadowed in system memory via driver • AC '97 codec register accesses are serialized via semaphore bit in PCI I/O space (new accesses are not allowed while a prior access is still in progress)
Power Management	<ul style="list-style-type: none"> • Power management via PCI Power Management
PCI Audio Function	<ul style="list-style-type: none"> • Read/write access to audio codec registers 00h–3Ah and vendor registers 5Ah–7Eh • 20-bit stereo PCM output, up to 48 kHz (L,R, Center, Sub-woofer, L-rear and R-rear channels on slots 3,4,6,7,8,9,10,11) • 16-bit stereo PCM input, up to 48 kHz (L,R channels on slots 3,4) • 16-bit mono mic in w/ or w/o mono mix, up to 48 kHz (L,R channel, slots 3,4) (mono mix supports mono hardware AEC reference for speakerphone) • 16-bit mono PCM input, up to 48 kHz from dedicated mic ADC (slot 6) (supports speech recognition or stereo hardware AEC ref for speakerphone) • During cold reset ACZ_RST# is held low until after POST and software de-assertion of ACZ_RST# (supports passive PC_BEEP to speaker connection during POST)

Table 5-56. Features Supported by Intel® ICH6 (Sheet 2 of 2)

Feature	Description
PCI Modem function	<ul style="list-style-type: none"> • Read/write access to modem codec registers 3Ch–58h and vendor registers 5Ah–7Eh • 16-bit mono modem line 1 output and input, up to 48 kHz (slot 5) • Low latency GPIO[15:0] via hardwired update between slot 12 and PCI I/O register • Programmable PCI interrupt on modem GPIO input changes via slot 12 GPIO_INT • SCI event generation on ACZ_SDIN[2:0] wake-up signal
AC-link	<ul style="list-style-type: none"> • AC '97 2.3 AC-link interface • Variable sample rate output support via AC '97 SLOTREQ protocol (slots 3,4,5,6,7,8,9,10,11) • Variable sample rate input support via monitoring of slot valid tag bits (slots 3,4,5,6) • 3.3 V digital operation meets AC '97 2.3 DC switching levels • AC-link I/O driver capability meets AC '97 2.3 triple codec specifications • Codec register status reads must be returned with data in the next AC-link frame, per AC '97 v2.3 Specification.
Multiple Codec	<ul style="list-style-type: none"> • Triple codec addressing: All AC '97 Audio codec register accesses are addressable to codec ID 00 (primary), codec ID 01 (secondary), or codec ID 10 (tertiary). • Modem codec addressing: All AC '97 Modem codec register accesses are addressable to codec ID 00 (primary) or codec ID 01 (secondary). • Triple codec receive capability via ACZ_SDIN[2:0] pins (ACZ_SDIN[2:0] frames are internally validated, synchronized, and OR'd depending on the Steer Enable bit status in the SDM register) • ACZ_SDIN mapping to DMA engine mapping capability allows for simultaneous input from two different audio codecs. <p>NOTES:</p> <ol style="list-style-type: none"> 1. Audio Codec IDs are remappable and not limited to 00,01,10. 2. Modem Codec IDs are remappable and limited to 00, 01. 3. When using multiple codecs, the Modem Codec must be ID 01.

Note: Throughout this document, references to D31:F5 indicate that the audio function exists in PCI Device 31, Function 5. References to D31:F6 indicate that the modem function exists in PCI Device 31, Function 6.

Note: Throughout this document references to tertiary, third, or triple codecs refer to the third codec in the system connected to the ACZ_SDIN2 pin. The AC '97 v2.3 Specification refers to non-primary codecs as multiple secondary codecs. To avoid confusion and excess verbiage, this datasheet refers to it as the third or tertiary codec.

Figure 5-11. Intel® ICH6-Based Audio Codec '97 Specification, Version 2.3

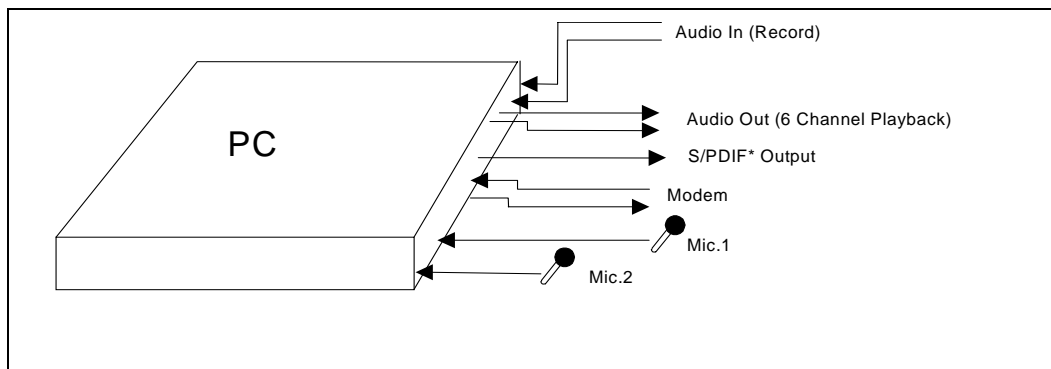

5.22.1 PCI Power Management

This Power Management section applies for all AC '97 controller functions. After a power management event is detected, the AC '97 controller wakes the host system. The following sections describe these events and the AC '97 controller power states.

Device Power States

The AC '97 controller supports D0 and D3 PCI Power Management states. The following are notes regarding the AC '97 controller implementation of the Device States:

1. The AC '97 controller hardware does not inherently consume any more power when it is in the D0 state than it does in D3 state. However, software can halt the DMA engine prior to entering these low power states such that the maximum power consumption is reduced.
2. In the D0 state, all implemented AC '97 controller features are enabled.
3. In D3 state, accesses to the AC '97 controller memory-mapped or I/O range results in master abort.
4. In D3 state, the AC '97 controller interrupt will never assert for any reason. The internal PME# signal is used to signal wake events, etc.
5. When the Device Power State field is written from D3_{HOT} to D0, an internal reset is generated. See [Section 17.1](#) for general rules on the effects of this reset.
6. AC97 STS bit is set only when the audio or modem resume events were detected and their respective PME enable bits were set.
7. GPIO Status change interrupt no longer has a direct path to the AC97 STS bit. This causes a wake up event only if the modem controller was in D3
8. Resume events on ACZ_SDIN[2:0] cause resume interrupt status bits to be set only if their respective controllers are not in D3.
9. Edge detect logic prevents the interrupts from being asserted in case the AC97 controller is switched from D3 to D0 after a wake event.
10. Once the interrupt status bits are set, they will cause PIRQB# if their respective enable bits were set. One of the audio or the modem drivers will handle the interrupt.

5.22.2 AC-Link Overview

The ICH6 is an AC '97 2.3 controller that communicates with companion codecs via a digital serial link called the AC-link. All digital audio/modem streams and command/status information is communicated over the AC-link.

The AC-link is a bi-directional, serial PCM digital stream. It handles multiple input and output data streams, as well as control register accesses, employing a time division multiplexed (TDM) scheme. The AC-link architecture provides for data transfer through individual frames transmitted in a serial fashion. Each frame is divided into 12 outgoing and 12 incoming data streams, or slots. The architecture of the ICH6 AC-link allows a maximum of three codecs to be connected. [Figure 5-12](#) shows a three codec topology of the AC-link for the ICH6. The AC-link consists of a five signal interface between the ICH6 and codec(s).

Note: The ICH6's AC '97 controller shares the signal interface with the Intel High Definition Audio controller. However, only one controller may be enabled at a time.

Figure 5-12. AC '97 2.3 Controller-Codec Connection

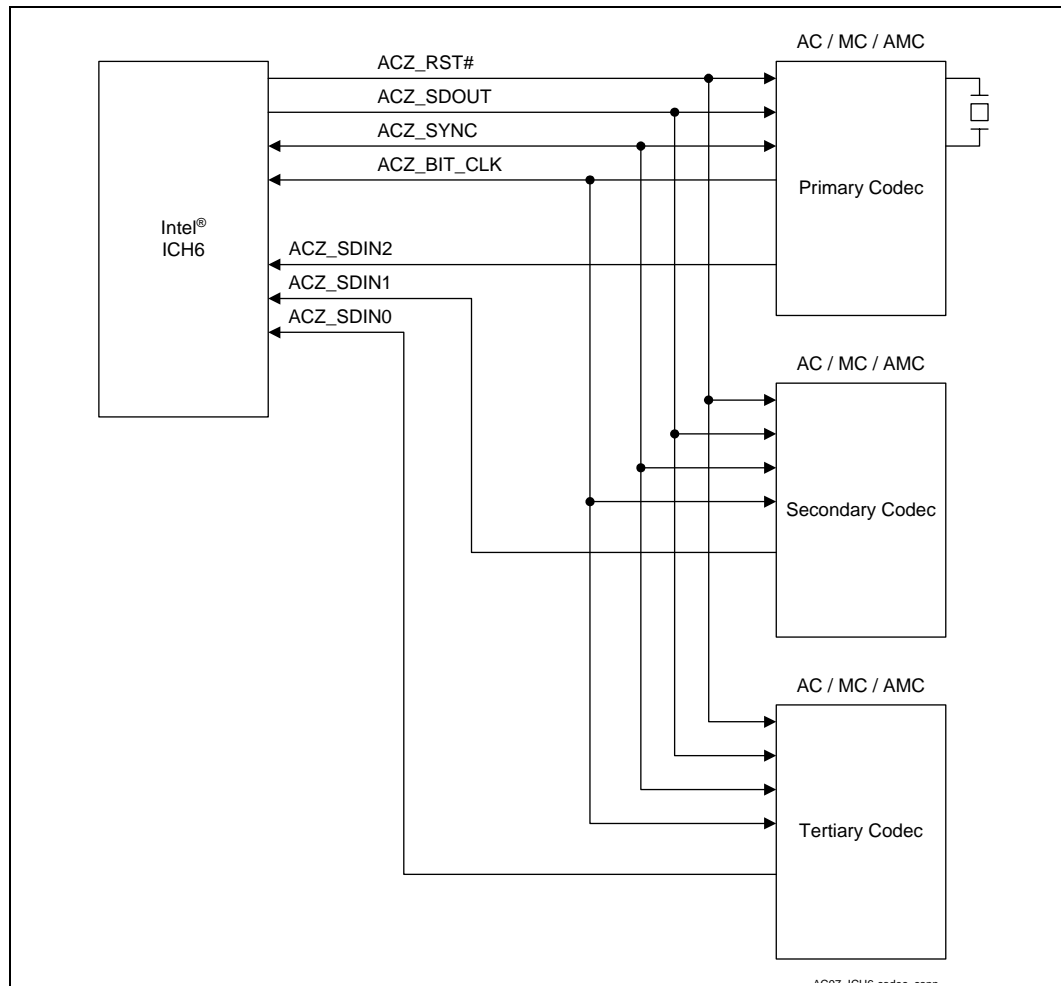

ICH6 core well outputs may be used as strapping options for the ICH6, sampled during system reset. These signals may have weak pullups/pulldowns; however, this will not interfere with link operation. ICH6 inputs integrate weak pulldowns to prevent floating traces when a secondary and/or tertiary codec is not attached. When the Shut Off bit in the control register is set, all buffers will be turned off and the pins will be held in a steady state, based on these pullups/pulldowns.

ACZ_BIT_CLK is fixed at 12.288 MHz and is sourced by the primary codec. It provides the necessary clocking to support the twelve 20-bit time slots. AC-link serial data is transitioned on each rising edge of ACZ_BIT_CLK. The receiver of AC-link data samples each serial bit on the falling edge of ACZ_BIT_CLK.

If ACZ_BIT_CLK makes no transitions for four consecutive PCI clocks, the ICH6 assumes the primary codec is not present or not working. It sets bit 28 of the Global Status Register (I/O offset 30h). All accesses to codec registers with this bit set will return data of FFh to prevent system hangs.

Synchronization of all AC-link data transactions is signaled by the AC '97 controller via the ACZ_SYNC signal, as shown in Figure 5-13. The primary codec drives the serial bit clock onto the AC-link, which the AC '97 controller then qualifies with the ACZ_SYNC signal to construct data frames. ACZ_SYNC, fixed at 48 kHz, is derived by dividing down ACZ_BIT_CLK. ACZ_SYNC remains high for a total duration of 16 ACZ_BIT_CLK at the beginning of each frame. The portion of the frame where ACZ_SYNC is high is defined as the tag phase. The remainder of the frame where ACZ_SYNC is low is defined as the data phase. Each data bit is sampled on the falling edge of ACZ_BIT_CLK.

Figure 5-13. AC-Link Protocol

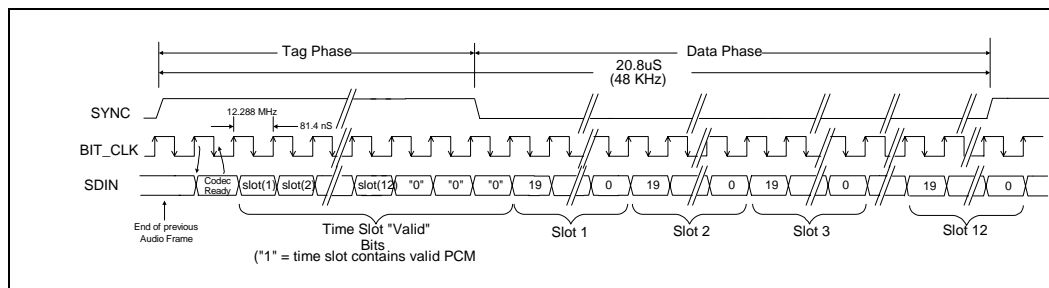

The ICH6 has three ACZ_SDIN pins allowing a single, dual, or triple codec configuration. When multiple codecs are connected, the primary, secondary, and tertiary codecs can be connected to any ACZ_SDIN line. The ICH6 does not distinguish between codecs on its ACZ_SDIN[2:0] pins, however the registers do distinguish between ACZ_SDIN[0], ACZ_SDIN[1], and ACZ_SDIN[2] for wake events, etc. If using a Modem Codec it is recommended to connect it to ACZ_SDIN1.

See your Platform Design Guide for a matrix of valid codec configurations. The ICH6 does not support optional test modes as outlined in the *AC '97 Specification, Version 2.3*.

5.22.2.1 Register Access

In the ICH6 implementation of the AC-link, up to three codecs can be connected to the SDOUT pin. The following mechanism is used to address the primary, secondary, and tertiary codecs individually.

The primary device uses bit 19 of slot 1 as the direction bit to specify read or write. Bits [18:12] of slot 1 are used for the register index. For I/O writes to the primary codec, the valid bits [14:13] for slots 1 and 2 must be set in slot 0, as shown in Table 5-57. Slot 1 is used to transmit the register address, and slot 2 is used to transmit data. For I/O reads to the primary codec, only slot 1 should be valid since only an address is transmitted. For I/O reads only slot 1 valid bit is set, while for I/O writes both slots 1 and 2 valid bits are set.

The secondary and tertiary codec registers are accessed using slots 1 and 2 as described above, however the slot valid bits for slots 1 and 2 are marked invalid in slot 0 and the codec ID bits [1:0] (bit 0 and bit 1 of slot 0) is set to a non-zero value. This allows the secondary or tertiary codec to monitor the slot valid bits of slots 1 and 2, and bits [1:0] of slot 0 to determine if the access is directed to the secondary or tertiary codec. If the register access is targeted to the secondary or tertiary codec, slot 1 and 2 will contain the address and data for the register access. Since slots 1 and 2 are marked invalid, the primary codec will ignore these accesses.

Table 5-57. Output Tag Slot 0

Bit	Primary Access Example	Secondary Access Example	Description
15	1	1	Frame Valid
14	1	0	Slot 1 Valid, Command Address bit (Primary codec only)
13	1	0	Slot 2 Valid, Command Data bit (Primary codec only)
12:3	X	X	Slot 3–12 Valid
2	0	0	Reserved
1:0	00	01	Codec ID (00 reserved for primary; 01 indicate secondary; 10 indicate tertiary)

When accessing the codec registers, only one I/O cycle can be pending across the AC-link at any time. The ICH6 implements write posting on I/O writes across the AC-link (i.e., writes across the link are indicated as complete before they are actually sent across the link). In order to prevent a second I/O write from occurring before the first one is complete, software must monitor the CAS bit in the Codec Access Semaphore register which indicates that a codec access is pending. Once the CAS bit is cleared, then another codec access (read or write) can go through. The exception to this being reads to offset 54h/D4h/154h (slot 12) which are returned immediately with the most recently received slot 12 data. Writes to offset 54h, D4h, and 154h (primary, secondary and tertiary codecs), get transmitted across the AC-link in slots 1 and 2 as a normal register access. Slot 12 is also updated immediately to reflect the data being written.

The controller does not issue back to back reads. It must get a response to the first read before issuing a second. In addition, codec reads and writes are only executed once across the link, and are not repeated.

5.22.3 AC-Link Low Power Mode

The AC-link signals can be placed in a low-power mode. When the AC '97 Powerdown register (26h), is programmed to the appropriate value, both ACZ_BIT_CLK and ACZ_SDIN will be brought to, and held at a logic low voltage level.

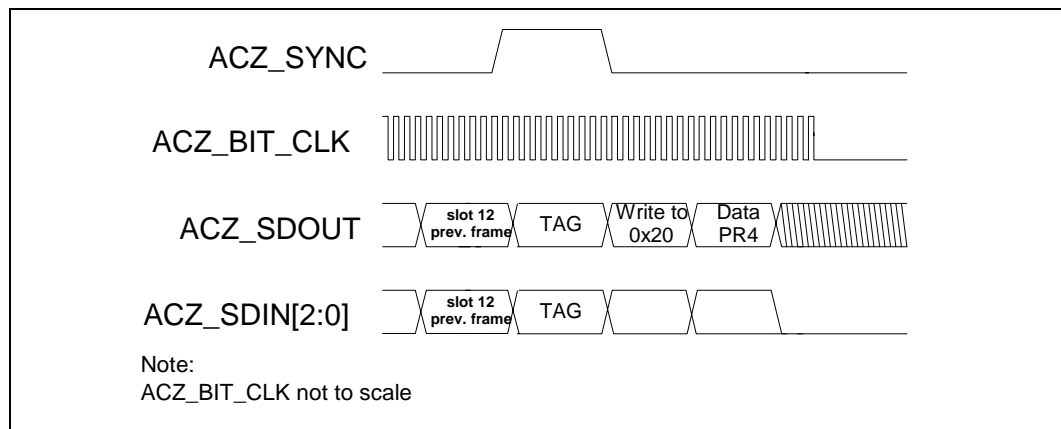
Figure 5-14. AC-Link Powerdown Timing

ACZ_BIT_CLK and ACZ_SDIN transition low immediately after a write to the Powerdown Register (26h) with PR4 enabled. When the AC '97 controller driver is at the point where it is ready to program the AC-link into its low-power mode, slots 1 and 2 are assumed to be the only valid stream in the audio output frame.

The AC '97 controller also drives ACZ_SYNC, and ACZ_SDOOUT low after programming AC '97 to this low power, halted mode

Once the codec has been instructed to halt, ACZ_BIT_CLK, a special wake up protocol must be used to bring the AC-link to the active mode since normal output and input frames can not be communicated in the absence of ACZ_BIT_CLK. Once in a low-power mode, the ICH6 provides three methods for waking up the AC-link; external wake event, cold reset and warm reset.

Note: Before entering any low-power mode where the link interface to the codec is expected to be powered down while the rest of the system is awake, the software must set the “Shut Off” bit in the control register.

5.22.3.1 External Wake Event

Codecs can signal the controller to wake the AC-link, and wake the system using ACZ_SDIN.

Figure 5-15. SDIN Wake Signaling

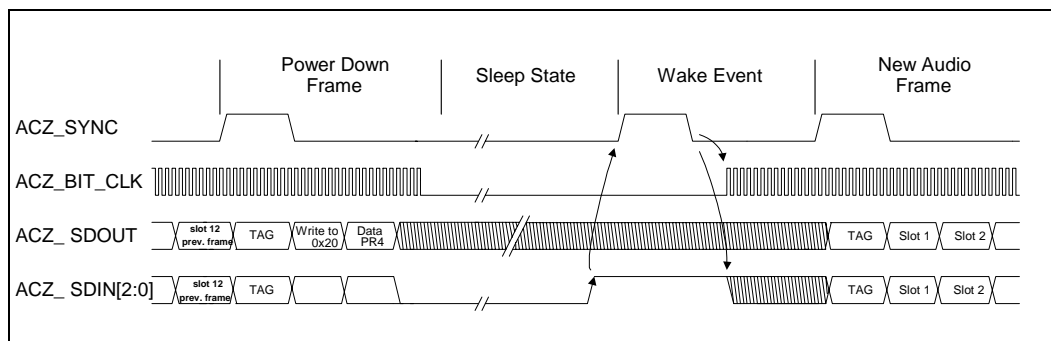

The minimum ACZ_SDIN wake up pulse width is 1 us. The rising edge of ACZ_SDIN[0], ACZ_SDIN[1] or ACZ_SDIN[2] causes the ICH6 to sequence through an AC-link warm reset and set the AC97_STS bit in the GPE0_STS register to wake the system. The primary codec must wait to sample ACZ_SYNC high and low before restarting ACZ_BIT_CLK as diagrammed in Figure 5-15. The codec that signaled the wake event must keep its ACZ_SDIN high until it has sampled ACZ_SYNC having gone high, and then low.

The AC-link protocol provides for a cold reset and a warm reset. The type of reset used depends on the system’s current power down state. Unless a cold or register reset (a write to the Reset register in the codec) is performed, wherein the AC '97 codec registers are initialized to their default values, registers are required to keep state during all power down modes.

Once powered down, activation of the AC-link via re-assertion of the ACZ_SYNC signal must not occur for a minimum of four audio frame times following the frame in which the power down was triggered. When AC-link powers up, it indicates readiness via the codec ready bit.

5.22.4 AC '97 Cold Reset

A cold reset is achieved by asserting ACZ_RST# for 1 μ s. By driving ACZ_RST# low, ACZ_BIT_CLK, and ACZ_SDOOUT will be activated and all codec registers will be initialized to their default power on reset values. ACZ_RST# is an asynchronous AC '97 input to the codec.

5.22.5 AC '97 Warm Reset

A warm reset re-activates the AC-link without altering the current codec register values. A warm reset is signaled by driving ACZ_SYNC high for a minimum of 1 μ s in the absence of ACZ_BIT_CLK.

Within normal frames, ACZ_SYNC is a synchronous AC '97 input to the codec. However, in the absence of ACZ_BIT_CLK, ACZ_SYNC is treated as an asynchronous input to the codec used in the generation of a warm reset.

The codec must not respond with the activation of ACZ_BIT_CLK until ACZ_SYNC has been sampled low again by the codec. This prevents the false detection of a new frame.

Note: On receipt of wake up signaling from the codec, the digital controller issues an interrupt if enabled. Software then has to issue a warm or cold reset to the codec by setting the appropriate bit in the Global Control Register.

5.22.6 Hardware Assist to Determine ACZ_SDIN Used Per Codec

Software first performs a read to one of the audio codecs. The read request goes out on ACZ_SDOOUT. Since the ICH6 allows one read to be performed at a time on the link, eventually the read data will come back in on one of the ACZ_SDIN[2:0] lines.

The codec does this by indicating that status data is valid in its TAG, then echoes the read address in slot 1 followed by the read data in slot 2.

The new function of the ICH6 hardware is to notice which ACZ_SDIN line contains the read return data, and to set new bits in the new register indicating which ACZ_SDIN line the register read data returned on. If it returned on ACZ_SDIN[0], bits [1:0] contain the value 00. If it returned on ACZ_SDIN[1], the bits contain the value 01, etc.

ICH6 hardware can set these bits every time register read data is returned from a function 5 read. No special command is necessary to cause the bits to be set. The new driver/BIOS software reads the bits from this register when it cares to, and can ignore it otherwise. When software is attempting to establish the codec-to-ACZ_SDIN mapping, it will single feed the read request and not pipeline to ensure it gets the right mapping, we cannot ensure the serialization of the access.

5.23 Intel® High Definition Audio (D27:F0)

5.23.1 Link Protocol Overview

The Intel High Definition Audio Link is the digital serial interface that connects HD audio codecs to the ICH6 HD audio controller. The HD audio link protocol is synchronous with the controller based on a fixed 24.000 MHz clock (ACZ_BIT_CLK), and is purely isochronous (no flow control), with a 48 KHz framing period. Separate input and output serial digital signals support multiple inbound and outbound streams, as well as fixed command and response channels.

Figure 5-16. Intel® High Definition Audio Link Protocol Example

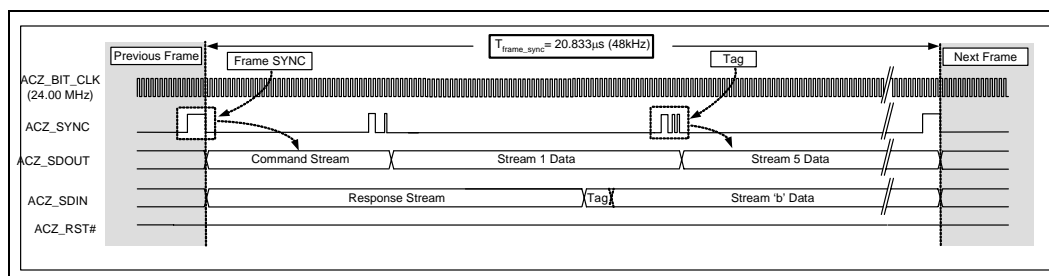

Since the HD Audio link is purely an isochronous transport mechanism, all link data transmission occurs within periodic time frames. A frame is defined as a 20.833 ms window of time marked by the falling edge of the Frame Sync marker, identifying the start of each frame. The HD Audio controller is responsible for generating the Frame Sync marker, which is a high-going pulse on the ACZ_SYNC signal, exactly 4 ACZ_BIT_CLK cycles in width.

5.23.1.1 Frame Composition

Basic inbound and outbound frames are made up of three major components: Command/Response field, Stream Packets, and Null fields.

5.23.1.1.1 Command/Response field

This field is used for link and codec management. One of these fields appears exactly once per frame, most significant bit first, and is always the first field in the frame. It is composed of a 40-bit Command Field on each outbound frame and a 36-bit Response Field on each inbound frame.

5.23.1.1.2 Stream Packet

A stream packet is the logical “envelop” in which data is transferred on the link. Since all data is associated with a given stream, each stream packet is delineated with an associated stream tag, which provides the stream ID or stream number of the packeted data. The stream packet is made up with zero or more sample blocks each of which has the same length (or sample size) and same time reference (or sample point). A sample block contains one or more samples, the number of which is specified by a control register. As an example, a monaural stream has one sample per sample block; a stereo stream has two samples per sample block; a 5.1 multi-channel stream has 6 samples per sample block, and so forth.

5.23.1.1.3 Null field

The remainder of bits contained in each inbound or outbound frame that are not used for Command / Response fields or for Stream Packets, are a null field. A null field is transmitted as logical zeros.

5.23.2 Link Reset

A link reset is signaled on the HD Audio link by assertion of the ACZ_RST# signal. Link reset results in all HD Audio codec and controller interface logic, including registers, being initialized to their default state. Note however, that codecs may contain critical logic associated with power management functions, such as power state information or Caller ID in a modem codec, that may or may not be reset depending on the state of the codec at the time that ACZ_RST# was asserted.

The link reset sequence occurs in response to three classes of events:

- Reset occurring on the HD Audio controller's host bus, including system power-up sequencing.
- Software initiating link reset.
- Certain software-initiated power management sequences.

Regardless of the reason for entering the link reset state, the link may be existed only under software control.

5.23.3 Link Power Management

The HD Audio link is designed to support all relevant power management features. In most cases, all power management state changes are driven by software, either through controller control registers, or Command verbs to Codecs. The exception to this is when a codec is put into a low power mode awaiting an external wake up event, such as a ring indication on a modem.

When the HD Audio link is commanded to enter a low power state, it enters the link reset state.

§



6 Register and Memory Mapping

The ICH6 contains registers that are located in the processor's I/O space and memory space and sets of PCI configuration registers that are located in PCI configuration space. This chapter describes the ICH6 I/O and memory maps at the register-set level. Register access is also described. Register-level address maps and Individual register bit descriptions are provided in the following chapters. The following notations and definitions are used in the register/instruction description chapters.

RO	Read Only. In some cases, If a register is read only, writes to this register location have no effect. However, in other cases, two separate registers are located at the same location where a read accesses one of the registers and a write accesses the other register. See the I/O and memory map tables for details.
WO	Write Only. In some cases, If a register is write only, reads to this register location have no effect. However, in other cases, two separate registers are located at the same location where a read accesses one of the registers and a write accesses the other register. See the I/O and memory map tables for details.
R/W	Read/Write. A register with this attribute can be read and written.
R/WC	Read/Write Clear. A register bit with this attribute can be read and written. However, a write of 1 clears (sets to 0) the corresponding bit and a write of 0 has no effect.
R/WO	Read/Write-Once. A register bit with this attribute can be written only once after power up. After the first write, the bit becomes read only.
R/WLO	Read/Write, Lock-Once. A register bit with this attribute can be written to the non-locked value multiple times, but to the locked value only once. After the locked value has been written, the bit becomes read only.
Default	When ICH6 is reset, it sets its registers to predetermined default states. The default state represents the minimum functionality feature set required to successfully bring up the system. Hence, it does not represent the optimal system configuration. It is the responsibility of the system initialization software to determine configuration, operating parameters, and optional system features that are applicable, and to program the ICH6 registers accordingly.
Bold	Register bits that are highlighted in bold text indicate that the bit is implemented in the ICH6. Register bits that are not implemented or are hardwired will remain in plain text.

6.1 PCI Devices and Functions

The ICH6 incorporates a variety of PCI functions as shown in [Table 6-1](#). These functions are divided into six logical devices (B0:D30, B0:D31, B0:D29, B0:D28, B0:D27 and B1:D8). D30 contains the DMI interface-to-PCI bridge and the AC '97 Audio and Modem controller. D31 contains the PCI-to-LPC bridge, IDE controller, SATA controller, and the SMBus controller. D29 contains the four USB UHCI controllers and one USB EHCI controller. D27 contains the Intel High Definition Audio controller. B1:D8 is the integrated LAN controller.

Note: From a software perspective, the integrated LAN controller resides on the ICH6's external PCI bus. This is typically Bus 1, but may be assigned a different number depending on system configuration.

If for some reason, the particular system platform does not want to support any one of the Device Functions, with the exception of D30:F0, they can individually be disabled. The integrated LAN controller will be disabled if no Platform LAN Connect component is detected (See [Chapter 5.3](#)). When a function is disabled, it does not appear at all to the software. A disabled function will not respond to any register reads or writes, insuring that these devices appear hidden to software.

Table 6-1. PCI Devices and Functions

Bus:Device:Function	Function Description
Bus 0:Device 30:Function 0	PCI-to-PCI Bridge
Bus 0:Device 30:Function 2	AC '97 Audio Controller
Bus 0:Device 30:Function 3	AC '97 Modem Controller
Bus 0:Device 31:Function 0	LPC Controller ¹
Bus 0:Device 31:Function 1	IDE Controller
Bus 0:Device 31:Function 2	SATA Controller
Bus 0:Device 31:Function 3	SMBus Controller
Bus 0:Device 29:Function 0	USB UHCI Controller 1
Bus 0:Device 29:Function 1	USB UHCI Controller 2
Bus 0:Device 29:Function 2	USB UHCI Controller 3
Bus 0:Device 29:Function 3	USB UHCI Controller 4
Bus 0:Device 29:Function 7	USB 2.0 EHCI Controller
Bus 0:Device 28:Function 0	PCI Express* Port 1
Bus 0:Device 28:Function 1	PCI Express Port 2
Bus 0:Device 28:Function 2	PCI Express Port 3
Bus 0:Device 28:Function 3	PCI Express Port 4
Bus 0:Device 27:Function 0	Intel High Definition Audio Controller
Bus n:Device 8:Function 0	LAN Controller

NOTES:

1. The LPC controller contains registers that control LPC, Power Management, System Management, GPIO, processor Interface, RTC, Interrupts, Timers, DMA.

6.2 PCI Configuration Map

Each PCI function on the ICH6 has a set of PCI configuration registers. The register address map tables for these register sets are included at the beginning of the chapter for the particular function.

Configuration Space registers are accessed through configuration cycles on the PCI bus by the Host bridge using configuration mechanism #1 detailed in the *PCI Local Bus Specification, Revision 2.3*.

Some of the PCI registers contain reserved bits. Software must deal correctly with fields that are reserved. On reads, software must use appropriate masks to extract the defined bits and not rely on reserved bits being any particular value. On writes, software must ensure that the values of reserved bit positions are preserved. That is, the values of reserved bit positions must first be read, merged with the new values for other bit positions and then written back. Note the software does not need to perform read, merge, write operation for the configuration address register.

In addition to reserved bits within a register, the configuration space contains reserved locations. Software should not write to reserved PCI configuration locations in the device-specific region (above address offset 3Fh).

6.3 I/O Map

The I/O map is divided into Fixed and Variable address ranges. Fixed ranges cannot be moved, but in some cases can be disabled. Variable ranges can be moved and can also be disabled.

6.3.1 Fixed I/O Address Ranges

Table 6-2 shows the Fixed I/O decode ranges from the processor perspective. Note that for each I/O range, there may be separate behavior for reads and writes. DMI (Direct Media Interface) cycles that go to target ranges that are marked as “Reserved” will not be decoded by the ICH6, and will be passed to PCI unless the Subtractive Decode Policy bit is set (D31:F0:Offset 42h, bit 0). If a PCI master targets one of the fixed I/O target ranges, it will be positively decoded by the ICH6 in medium speed.

Address ranges that are not listed or marked “Reserved” are **not** decoded by the ICH6 (unless assigned to one of the variable ranges).

Table 6-2. Fixed I/O Ranges Decoded by Intel® ICH6 (Sheet 1 of 2)

I/O Address	Read Target	Write Target	Internal Unit
00h–08h	DMA Controller	DMA Controller	DMA
09h–0Eh	RESERVED	DMA Controller	DMA
0Fh	DMA Controller	DMA Controller	DMA
10h–18h	DMA Controller	DMA Controller	DMA
19h–1Eh	RESERVED	DMA Controller	DMA
1Fh	DMA Controller	DMA Controller	DMA
20h–21h	Interrupt Controller	Interrupt Controller	Interrupt
24h–25h	Interrupt Controller	Interrupt Controller	Interrupt
28h–29h	Interrupt Controller	Interrupt Controller	Interrupt
2Ch–2Dh	Interrupt Controller	Interrupt Controller	Interrupt
2E–2F	LPC SIO	LPC SIO	Forwarded to LPC
30h–31h	Interrupt Controller	Interrupt Controller	Interrupt
34h–35h	Interrupt Controller	Interrupt Controller	Interrupt
38h–39h	Interrupt Controller	Interrupt Controller	Interrupt
3Ch–3Dh	Interrupt Controller	Interrupt Controller	Interrupt
40h–42h	Timer/Counter	Timer/Counter	PIT (8254)
43h	RESERVED	Timer/Counter	PIT
4E–4F	LPC SIO	LPC SIO	Forwarded to LPC
50h–52h	Timer/Counter	Timer/Counter	PIT
53h	RESERVED	Timer/Counter	PIT
60h	Microcontroller	Microcontroller	Forwarded to LPC
61h	NMI Controller	NMI Controller	Processor I/F
62h	Microcontroller	Microcontroller	Forwarded to LPC
64h	Microcontroller	Microcontroller	Forwarded to LPC
66h	Microcontroller	Microcontroller	Forwarded to LPC
70h	RESERVED	NMI and RTC Controller	RTC
71h	RTC Controller	RTC Controller	RTC
72h	RTC Controller	NMI and RTC Controller	RTC
73h	RTC Controller	RTC Controller	RTC
74h	RTC Controller	NMI and RTC Controller	RTC
75h	RTC Controller	RTC Controller	RTC
76h	RTC Controller	NMI and RTC Controller	RTC
77h	RTC Controller	RTC Controller	RTC
80h	DMA Controller, or LPC, or PCI	DMA Controller and LPC or PCI	DMA
81h–83h	DMA Controller	DMA Controller	DMA
84h–86h	DMA Controller	DMA Controller and LPC or PCI	DMA
87h	DMA Controller	DMA Controller	DMA

Table 6-2. Fixed I/O Ranges Decoded by Intel® ICH6 (Sheet 2 of 2)

I/O Address	Read Target	Write Target	Internal Unit
88h	DMA Controller	DMA Controller and LPC or PCI	DMA
89h–8Bh	DMA Controller	DMA Controller	DMA
8Ch–8Eh	DMA Controller	DMA Controller and LPC or PCI	DMA
08Fh	DMA Controller	DMA Controller	DMA
90h–91h	DMA Controller	DMA Controller	DMA
92h	Reset Generator	Reset Generator	Processor I/F
93h–9Fh	DMA Controller	DMA Controller	DMA
A0h–A1h	Interrupt Controller	Interrupt Controller	Interrupt
A4h–A5h	Interrupt Controller	Interrupt Controller	Interrupt
A8h–A9h	Interrupt Controller	Interrupt Controller	Interrupt
ACh–ADh	Interrupt Controller	Interrupt Controller	Interrupt
B0h–B1h	Interrupt Controller	Interrupt Controller	Interrupt
B2h–B3h	Power Management	Power Management	Power Management
B4h–B5h	Interrupt Controller	Interrupt Controller	Interrupt
B8h–B9h	Interrupt Controller	Interrupt Controller	Interrupt
BCh–BDh	Interrupt Controller	Interrupt Controller	Interrupt
C0h–D1h	DMA Controller	DMA Controller	DMA
D2h–DDh	RESERVED	DMA Controller	DMA
DEh–DFh	DMA Controller	DMA Controller	DMA
F0h	PCI and Master Abort ¹	FERR#/IGNNE# / Interrupt Controller	Processor I/F
170h–177h	IDE Controller, SATA Controller, or PCI	IDE Controller, SATA Controller, or PCI	Forwarded to IDE or SATA
1F0h–1F7h	IDE Controller, SATA Controller, or PCI ²	IDE Controller, SATA Controller, or PCI	Forwarded to IDE or SATA
376h	IDE Controller, SATA Controller, or PCI	IDE Controller, SATA Controller, or PCI	Forwarded to IDE or SATA
3F6h	IDE Controller, SATA Controller, or PCI ²	IDE Controller, SATA Controller, or PCI	Forwarded IDE or SATA
4D0h–4D1h	Interrupt Controller	Interrupt Controller	Interrupt
CF9h	Reset Generator	Reset Generator	Processor I/F

NOTES:

1. A read to this address will subtractively go to PCI, where it will master abort.
2. Only if IDE I/O space is enabled (D31:F1:40 bit 15) and the IDE controller is in legacy mode. Otherwise, the target is PCI.

6.3.2 Variable I/O Decode Ranges

Table 6-3 shows the Variable I/O Decode Ranges. They are set using Base Address Registers (BARs) or other configuration bits in the various PCI configuration spaces. The PNP software (PCI or ACPI) can use their configuration mechanisms to set and adjust these values.

Warning: The Variable I/O Ranges should not be set to conflict with the Fixed I/O Ranges. Unpredictable results if the configuration software allows conflicts to occur. The ICH6 does not perform any checks for conflicts.

Table 6-3. Variable I/O Decode Ranges

Range Name	Mappable	Size (Bytes)	Target
ACPI	Anywhere in 64 KB I/O Space	64	Power Management
IDE Bus Master	Anywhere in 64 KB I/O Space	16	IDE Unit
Native IDE Command	Anywhere in 64 KB I/O Space	8	IDE Unit
Native IDE Control	Anywhere in 64 KB I/O Space	4	IDE Unit
USB UHCI Controller #1	Anywhere in 64 KB I/O Space	32	USB Unit 1
USB UHCI Controller #2	Anywhere in 64 KB I/O Space	32	USB Unit 2
USB UHCI Controller #3	Anywhere in 64 KB I/O Space	32	USB Unit 3
USB UHCI Controller #4	Anywhere in 64 KB I/O Space	32	USB Unit 4
SMBus	Anywhere in 64 KB I/O Space	32	SMB Unit
AC '97 Audio Mixer	Anywhere in 64 KB I/O Space	256	AC '97 Unit
AC '97 Audio Bus Master	Anywhere in 64 KB I/O Space	64	AC '97 Unit
AC '97 Modem Mixer	Anywhere in 64 KB I/O Space	256	AC '97 Unit
AC '97 Modem Bus Master	Anywhere in 64 KB I/O Space	128	AC '97 Unit
TCO	96 Bytes above ACPI Base	32	TCO Unit
GPIO	Anywhere in 64 KB I/O Space	64	GPIO Unit
Parallel Port	3 Ranges in 64 KB I/O Space	8	LPC Peripheral
Serial Port 1	8 Ranges in 64 KB I/O Space	8	LPC Peripheral
Serial Port 2	8 Ranges in 64 KB I/O Space	8	LPC Peripheral
Floppy Disk Controller	2 Ranges in 64 KB I/O Space	8	LPC Peripheral
LAN	Anywhere in 64 KB I/O Space	64	LAN Unit
LPC Generic 1	Anywhere in 64 KB I/O Space	128	LPC Peripheral
LPC Generic 2	Anywhere in 64 KB I/O Space	16, 32, or 641	LPC Peripheral
I/O Trapping Ranges	Anywhere in 64 KB I/O Space	1 to 256	Trap on Backbone

NOTE:

1. Decode range size determined by D31:F0:ADh:bits 5:4

6.4 Memory Map

Table 6-4 shows (from the processor perspective) the memory ranges that the ICH6 decodes. Cycles that arrive from DMI that are not directed to any of the internal memory targets that decode directly from DMI will be driven out on PCI unless the Subtractive Decode Policy bit is set (D31:F0:Offset 42h, bit 0). The ICH6 may then claim the cycle for the internal LAN controller.

PCI cycles generated by external PCI masters will be positively decoded unless they fall in the PCI-to-PCI bridge memory forwarding ranges (those addresses are reserved for PCI peer-to-peer traffic). If the cycle is not in the internal LAN controller's range, it will be forwarded up to DMI. Software must not attempt locks to the ICH6's memory-mapped I/O ranges for EHCI and HPET. If attempted, the lock is not honored which means potential deadlock conditions may occur.

Table 6-4. Memory Decode Ranges from Processor Perspective (Sheet 1 of 2)

Memory Range	Target	Dependency/Comments
0000 0000h–000D FFFFh 0010 0000h–TOM (Top of Memory)	Main Memory	TOM registers in Host controller
000E 0000h–000E FFFFh	Firmware Hub	Bit 6 in Firmware Hub Decode Enable register is set
000F 0000h–000F FFFFh	Firmware Hub	Bit 7 in Firmware Hub Decode Enable register is set
FEC0 0000h–FEC0 0100h	I/O APIC inside ICH6	
FFC0 0000h–FFC7 FFFFh FF80 0000h–FF87 FFFFh	Firmware Hub (or PCI) ³	Bit 8 in Firmware Hub Decode Enable register is set
FFC8 0000h–FFCF FFFFh FF88 0000h–FF8F FFFFh	Firmware Hub (or PCI) ³	Bit 9 in Firmware Hub Decode Enable register is set
FFD0 0000h–FFD7 FFFFh FF90 0000h–FF97 FFFFh	Firmware Hub (or PCI) ³	Bit 10 in Firmware Hub Decode Enable register is set
FFD8 0000h–FFDF FFFFh FF98 0000h–FF9F FFFFh	Firmware Hub (or PCI) ³	Bit 11 in Firmware Hub Decode Enable register is set
FFE0 000h–FFE7 FFFFh FFA0 0000h–FFA7 FFFFh	Firmware Hub (or PCI) ³	Bit 12 in Firmware Hub Decode Enable register is set
FFE8 0000h–FFEF FFFFh FFA8 0000h–FFAF FFFFh	Firmware Hub (or PCI) ³	Bit 13 in Firmware Hub Decode Enable register is set
FFF0 0000h–FFF7 FFFFh FFB0 0000h–FFB7 FFFFh	Firmware Hub (or PCI) ³	Bit 14 in Firmware Hub Decode Enable register is set
FFF8 0000h–FFFF FFFFh FFB8 0000h–FFBF FFFFh	Firmware Hub (or PCI) ³	Always enabled. The top two, 64 KB blocks of this range can be swapped, as described in Section 7.4.1 .
FF70 0000h–FF7F FFFFh FF30 0000h–FF3F FFFFh	Firmware Hub (or PCI) ³	Bit 3 in Firmware Hub Decode Enable register is set
FF60 0000h–FF6F FFFFh FF20 0000h–FF2F FFFFh	Firmware Hub (or PCI) ³	Bit 2 in Firmware Hub Decode Enable register is set
FF50 0000h–FF5F FFFFh FF10 0000h–FF1F FFFFh	Firmware Hub (or PCI) ³	Bit 1 in Firmware Hub Decode Enable register is set
FF40 0000h–FF4F FFFFh FF00 0000h–FF0F FFFFh	Firmware Hub (or PCI) ³	Bit 0 in Firmware Hub Decode Enable register is set

Table 6-4. Memory Decode Ranges from Processor Perspective (Sheet 2 of 2)

Memory Range	Target	Dependency/Comments
4 KB anywhere in 4-GB range	Integrated LAN Controller ¹	Enable via BAR in Device 29:Function 0 (Integrated LAN Controller)
1 KB anywhere in 4-GB range	USB EHCI Controller ²	Enable via standard PCI mechanism (Device 29, Function 7)
512 B anywhere in 4-GB range	AC '97 Host Controller (Mixer)	Enable via standard PCI mechanism (Device 30, Function 2)
256 B anywhere in 4-GB range	AC '97 Host Controller (Bus Master)	Enable via standard PCI mechanism (Device 30, Function 3)
512 B anywhere in 64-bit addressing space	Intel High Definition Audio Host Controller	Enable via standard PCI mechanism (Device 30, Function 1)
FED0 X000h–FED0 X3FFh	High Precision Event Timers ²	BIOS determines the “fixed” location which is one of four, 1-KB ranges where X (in the first column) is 0h, 1h, 2h, or 3h.
All other	PCI	None

NOTES:

1. Only LAN cycles can be seen on PCI.
2. Software must not attempt locks to memory mapped I/O ranges for USB EHCI or High Precision Event Timers. If attempted, the lock is not honored, which means potential deadlock conditions may occur.
3. PCI is the target when the Boot BIOS Destination selection bit is low (Chipset Configuration Registers:Offset 3401:bit 3). When PCI selected, the Firmware Hub Decode Enable bits have no effect.

6.4.1 Boot-Block Update Scheme

The ICH6 supports a “top-block swap” mode that has the ICH6 swap the top block in the Firmware Hub (the boot block) with another location. This allows for safe update of the Boot Block (even if a power failure occurs). When the “TOP_SWAP” Enable bit is set, the ICH6 will invert A16 for cycles targeting Firmware Hub space. When this bit is 0, the ICH6 will not invert A16. This bit is automatically set to 0 by RTCRST#, but not by PLTRST#.

The scheme is based on the concept that the top block is reserved as the “boot” block, and the block immediately below the top block is reserved for doing boot-block updates.

The algorithm is:

1. Software copies the top block to the block immediately below the top
2. Software checks that the copied block is correct. This could be done by performing a checksum calculation.
3. Software sets the TOP_SWAP bit. This will invert A16 for cycles going to the Firmware Hub. processor access to FFFF_0000h through FFFF_FFFFh will be directed to FFFE_0000h through FFFE_FFFFh in the Firmware Hub, and processor accesses to FFFE_0000h through FFFE_FFFF will be directed to FFFF_0000h through FFFF_FFFFh.
4. Software erases the top block
5. Software writes the new top block
6. Software checks the new top block
7. Software clears the TOP_SWAP bit
8. Software sets the Top_Swap Lock-Down bit

If a power failure occurs at any point after step 3, the system will be able to boot from the copy of the boot block that is stored in the block below the top. This is because the TOP_SWAP bit is backed in the RTC well.

Note: The top-block swap mode may be forced by an external strapping option (See [Section 2.22.1](#)). When top-block swap mode is forced in this manner, the TOP_SWAP bit cannot be cleared by software. A re-boot with the strap removed will be required to exit a forced top-block swap mode.

Note: Top-block swap mode only affects accesses to the Firmware Hub space, not feature space.

Note: The top-block swap mode has no effect on accesses below FFFE_0000h.

§



7 Chipset Configuration Registers

This section describes all registers and base functionality that is related to chipset configuration and not a specific interface (such as LPC, PCI, or PCI Express*). It contains the root complex register block, which describes the behavior of the upstream internal link.

This block is mapped into memory space, using register RCBA of the PCI-to-LPC bridge. Accesses in this space must be limited to 32-(DW) bit quantities. Burst accesses are not allowed.

7.1 Chipset Configuration Registers (Memory Space)

Note: Address locations that are not shown should be treated as Reserved (see Section 6.2 for details).

Table 7-1. Chipset Configuration Register Memory Map (Memory Space) (Sheet 1 of 3)

Offset	Mnemonic	Register Name	Default	Type
0000–0003h	VCH	Virtual Channel Capability Header	10010002h	RO
0004–0007h	VCAP1	Virtual Channel Capability #1	00000801h	RO
0008–000Bh	VCAP2	Virtual Channel Capability #2	00000001h	RO
000C–000Dh	PVC	Port VC Control	0000h	R/W, RO
000E–000Fh	PVS	Port VC Status	0000h	RO
0010–0013h	V0CAP	VC 0 Resource Capability	00000001h	RO
0014–0017h	V0CTL	VC 0 Resource Control	800000FFh	R/W, RO
001A–001Bh	V0STS	VC 0 Resource Status	0000h	RO
0100–0103h	RCTCL	Root Complex Topology Capability List	1A010005h	RO
0104–0107h	ESD	Element Self Description	00000602h	R/WO, RO
0110–0113h	ULD	Upstream Link Descriptor	00000001h	R/WO, RO
0118–011Fh	ULBA	Upstream Link Base Address	0000000000000000h	R/WO
0120–0123h	RP1D	Root Port 1 Descriptor	01xx0002h	R/WO, RO
0128–012Fh	RP1BA	Root Port 1 Base Address	00000000000E0000h	RO
0130–0133h	RP2D	Root Port 2 Descriptor	02xx0002h	R/WO, RO
0138–013Fh	RP2BA	Root Port 2 Base Address	00000000000E1000h	RO
0140–0143h	RP3D	Root Port 3 Descriptor	03xx0002h	R/WO, RO
0148–014Fh	RP3BA	Root Port 3 Base Address	00000000000E2000h	RO
0150–0153h	RP4D	Root Port 4 Descriptor	04xx0002h	R/WO, RO
0158–015Fh	RP4BA	Root Port 4 Base Address	00000000000E3000h	RO
0160–0163h	HDD	Intel High Definition Audio Descriptor	05xx0002h	R/WO, RO
0168–016Fh	HDBA	Intel High Definition Audio Base Address	00000000000D8000h	RO
01A0–01A3h	ILCL	Internal Link Capability List	00010006h	RO

Table 7-1. Chipset Configuration Register Memory Map (Memory Space) (Sheet 2 of 3)

Offset	Mnemonic	Register Name	Default	Type
01A4–01A7h	LCAP	Link Capabilities	00012441h	RO, R/WO
01A8–01A9h	LCTL	Link Control	0000h	R/W
01AA–01ABh	LSTS	Link Status	0041h	RO
0200–0203h	CSIR5	Chipset Initialization Register 5	01100220h	R/W
020C–020Fh	CSIR6	Chipset Initialization Register 6	00201004h	R/W
0220–0223h	BCR	Backbone Configuration Register	00008000h	R/W
0224–0227h	RPC	Root Port Configuration	0000000xh	R/W, RO
1D40–1D43h	CSIR7	Chipset Initialization Register 7	00000000	R/W
1E00–1E03h	TRSR	Trap Status Register	00h	R/WC, RO
1E10–1E17h	TRCR	Trapped Cycle Register	0000000000000000h	RO
1E18–1E1Fh	TWDR	Trapped Write Data Register	0000000000000000h	RO
1E80–1E87h	IOTR0	I/O Trap Register 0	0000000000000000h	R/W, RO
1E88–1E8Fh	IOTR1	I/O Trap Register 1	0000000000000000h	R/W, RO
1E90–1E97h	IOTR2	I/O Trap Register 2	0000000000000000h	R/W, RO
1E98–1E9Fh	IOTR3	I/O Trap Register 3	0000000000000000h	R/W, RO
2010–2013h	DMC	DMI Misc. Control (Mobile Only)	N/A	R/W
2020–2023h	CSCR1	Chipset Configuration Register 1	00C4B0DBh	R/W
2027h	CSCR2	Chipset Configuration Register 2	0Ah	R/W
2078–207Bh	PLLMC	PLL Misc. Control (Mobile Only)	N/A	R/W
3000–3001h	TCTL	TCO Control	00h	R/W
3100–3103h	D31IP	Device 31 Interrupt Pin	00042210h	R/W, RO
3104–3107h	D30IP	Device 30 Interrupt Pin	00002100h	R/W, RO
3108–310Bh	D29IP	Device 29 Interrupt Pin	10004321h	R/W
310C–310Fh	D28IP	Device 28 Interrupt Pin	00004321h	R/W
3110–3113h	D27IP	Device 27 Interrupt Pin	00000001h	R/W
3140–3141h	D31IR	Device 31 Interrupt Route	3210h	R/W
3142–3143h	D30IR	Device 30 Interrupt Route	3210h	R/W
3144–3145h	D29IR	Device 29 Interrupt Route	3210h	R/W
3146–3147h	D28IR	Device 28 Interrupt Route	3210h	R/W
3148–3149h	D27IR	Device 27 Interrupt Route	3210h	R/W
31FF–31FFh	OIC	Other Interrupt Control	00h	R/W
3400–3403h	RC	RTC Configuration	00000000h	R/W, R/WLO
3404–3407h	HPTC	High Precision Timer Configuration	00000000h	R/W
3410–3413h	GCS	General Control and Status	0000000xh	R/W, R/WLO
3414–3414h	BUC	Backed Up Control	0000001xb (Mobile) 0000000xb (Desktop)	R/W
3418–341Bh	FD	Function Disable	See bit description	R/W, RO

Table 7-1. Chipset Configuration Register Memory Map (Memory Space) (Sheet 3 of 3)

Offset	Mnemonic	Register Name	Default	Type
341C–341Fh	CG	Clock Gating	00000000h	R/W, RO
3E08–3E09h	CSIR1	Chipset Initialization Register 1	0000h	R/W
3E0Eh	CSIR3	Chipset Initialization Register 4	00h	R/W
3E48–3E49h	CSIR2	Chipset Initialization Register 2	0000h	R/W
3E4Eh	CSIR4	Chipset Initialization Register 4	00h	R/W

7.1.1 VCH—Virtual Channel Capability Header Register

Offset Address: 0000–0003h Attribute: RO
 Default Value: 10010002h Size: 32-bit

Bit	Description
31:20	Next Capability Offset (NCO) — RO. This field indicates the next item in the list.
19:16	Capability Version (CV) — RO. This field indicates support as a version 1 capability structure.
15:0	Capability ID (CID) — RO. This field indicates this is the Virtual Channel capability item.

7.1.2 VCAP1—Virtual Channel Capability #1 Register

Offset Address: 0004–0007h Attribute: RO
 Default Value: 00000801h Size: 32-bit

Bit	Description
31:12	Reserved
11:10	Port Arbitration Table Entry Size (PATS) — RO. This field indicates the size of the port arbitration table is 4 bits (to allow up to 8 ports).
9:8	Reference Clock (RC) — RO. Fixed at 100 ns.
7	Reserved
6:4	Low Priority Extended VC Count (LPEVC) — RO. This field indicates that there are no additional VCs of low priority with extended capabilities.
3:0	Reserved

7.1.3 VCAP2—Virtual Channel Capability #2 Register

Offset Address: 0008–000Bh Attribute: RO
 Default Value: 00000001h Size: 32-bit

Bit	Description
31:24	VC Arbitration Table Offset (ATO) — RO. This bit indicates that no table is present for VC arbitration since it is fixed.
23:0	Reserved

7.1.4 PVC—Port Virtual Channel Control Register

Offset Address: 000C–000Dh Attribute: R/W, RO
 Default Value: 0000h Size: 16-bit

Bit	Description
15:04	Reserved
3:1	VC Arbitration Select (AS) — RO. This bit indicates which VC should be programmed in the VC arbitration table. The root complex takes no action on the setting of this field since there is no arbitration table.
0	Load VC Arbitration Table (LAT) — RO. This bit indicates that the table programmed should be loaded into the VC arbitration table. This bit is defined as read/write with always returning 0 on reads.

7.1.5 PVS—Port Virtual Channel Status Register

Offset Address: 000E–000Fh Attribute: RO
 Default Value: 0000h Size: 16-bit

Bit	Description
15:01	Reserved
0	VC Arbitration Table Status (VAS) — RO. This bit indicates the coherency status of the VC Arbitration table when it is being updated. This field is always 0 in the root complex since there is no VC arbitration table.

7.1.6 V0CAP—Virtual Channel 0 Resource Capability Register

Offset Address: 0010–0013h Attribute: RO
 Default Value: 00000001h Size: 32-bit

Bit	Description
31:24	Port Arbitration Table Offset (AT) — RO. This VC implements no port arbitration table since the arbitration is fixed.
23	Reserved
22:16	Maximum Time Slots (MTS) — RO. This VC implements fixed arbitration, and therefore this field is not used.
15	Reject Snoop Transactions (RTS) — RO. This VC must be able to take snoopable transactions.
14	Advanced Packet Switching (APS) — RO. This VC is capable of all transactions, not just advanced packet switching transactions.
13:8	Reserved
7:0	Port Arbitration Capability (PAC) — RO. This field indicates that this VC uses fixed port arbitration.

7.1.7 V0CTL—Virtual Channel 0 Resource Control Register

Offset Address: 0014–0017h Attribute: R/W, RO
 Default Value: 800000FFh Size: 32-bit

Bit	Description
31	Virtual Channel Enable (EN) — RO. Always set to 1. VC0 is always enabled and cannot be disabled.
30:27	Reserved
26:24	Virtual Channel Identifier (ID) — RO. This field indicates the ID to use for this virtual channel.
23:20	Reserved
19:17	Port Arbitration Select (PAS) — R/W. Indicates which port table is being programmed. The root complex takes no action on this setting since the arbitration is fixed and there is no arbitration table.
16	Load Port Arbitration Table (LAT) — RO. The root complex does not implement an arbitration table for this virtual channel.
15:8	Reserved
7:1	Transaction Class / Virtual Channel Map (TVM) — R/W. This field indicates which transaction classes are mapped to this virtual channel. When a bit is set, this transaction class is mapped to the virtual channel.
0	Reserved

7.1.8 V0STS—Virtual Channel 0 Resource Status Register

Offset Address: 001A–001Bh Attribute: RO
 Default Value: 0000h Size: 16-bit

Bit	Description
15:02	Reserved
1	VC Negotiation Pending (NP) — RO. 1 = Virtual channel is still being negotiated with ingress ports.
0	Port Arbitration Tables Status (ATS) — RO. There is no port arbitration table for this VC, so this bit is reserved at 0.

7.1.9 RCTCL—Root Complex Topology Capabilities List Register

Offset Address: 0100–0103h Attribute: RO
 Default Value: 1A010005h Size: 32-bit

Bit	Description
31:20	Next Capability (NEXT) — RO. This field indicates the next item in the list.
19:16	Capability Version (CV) — RO. This field indicates the version of the capability structure.
15:0	Capability ID (CID) — RO. This field indicates this is a PCI Express* link capability section of an RCRB.

7.1.10 ESD—Element Self Description Register

Offset Address: 0104–0107h Attribute: R/WO, RO
 Default Value: 00000602h Size: 32-bit

Bit	Description
31:24	Port Number (PN) — RO. A value of 0 to indicate the egress port for the Intel® ICH6.
23:16	Component ID (CID) — R/WO. This field indicates the component ID assigned to this element by software. This is written once by platform BIOS and is locked until a platform reset.
15:8	Number of Link Entries (NLE) — RO. This field indicates that one link entry (corresponding to DMI), 4 root port entries (for the downstream ports), and the Intel High Definition Audio device are described by this RCRB.
7:4	Reserved
3:0	Element Type (ET) — RO. This field indicates that the element type is a root complex internal link.

7.1.11 ULD—Upstream Link Descriptor Register

Offset Address: 0110–0113h Attribute: R/WO, RO
 Default Value: 00000001h Size: 32-bit

Bit	Description
31:24	Target Port Number (PN) — R/WO. This field is programmed by platform BIOS to match the port number of the (G)MCH RCRB that is attached to this RCRB.
23:16	Target Component ID (TCID) — R/WO. This field is programmed by platform BIOS to match the component ID of the (G)MCH RCRB that is attached to this RCRB.
15:2	Reserved
1	Link Type (LT) — RO. This bit indicates that the link points to the (G)MCH RCRB.
0	Link Valid (LV) — RO. This bit indicates that the link entry is valid.

7.1.12 ULBA—Upstream Link Base Address Register

Offset Address: 0118–011Fh Attribute: R/WO
 Default Value: 0000000000000000h Size: 64-bit

Bit	Description
63:32	Base Address Upper (BAU) — R/WO. This field is programmed by platform BIOS to match the upper 32-bits of base address of the (G)MCH RCRB that is attached to this RCRB.
31:0	Base Address Lower (BAL) — R/WO. This field is programmed by platform BIOS to match the lower 32-bits of base address of the (G)MCH RCRB that is attached to this RCRB.

7.1.13 RP1D—Root Port 1 Descriptor Register

Offset Address: 0120–0123h Attribute: R/WO, RO
 Default Value: 01xx0002h Size: 32-bit

Bit	Description
31:24	Target Port Number (PN) — RO. This field indicates the target port number is 1h (root port #1).
23:16	Target Component ID (TCID) — R/WO. This field returns the value of the ESD.CID (offset 0104h, bits 23:16) field programmed by platform BIOS, since the root port is in the same component as the RCRB.
15:2	Reserved
1	Link Type (LT) — RO. This bit indicates that the link points to a root port.
0	Link Valid (LV) — RO. When FD.PE1D (offset 3418h, bit 16) is set, this link is not valid (returns 0). When FD.PE1D is cleared, this link is valid (returns 1).

7.1.14 RP1BA—Root Port 1 Base Address Register

Offset Address: 0128–012Fh Attribute: RO
 Default Value: 00000000000E0000h Size: 64-bit

Bit	Description
63:32	Reserved
31:28	Reserved
27:20	Bus Number (BN) — RO. This field indicates the root port is on bus #0.
19:15	Device Number (DN) — RO. This field indicates the root port is on device #28.
14:12	Function Number (FN) — RO. This field indicates the root port is on function #0.
11:0	Reserved

7.1.15 RP2D—Root Port 2 Descriptor Register

Offset Address: 0130–0133h Attribute: R/WO, RO
 Default Value: 02xx0002h Size: 32-bit

Bit	Description
31:24	Target Port Number (PN) — RO. This field indicates the target port number is 2h (root port #2).
23:16	Target Component ID (TCID) — R/WO. This field returns the value of the ESD.CID (offset 0104h, bits 23:16) field programmed by platform BIOS, since the root port is in the same component as the RCRB.
15:2	Reserved
1	Link Type (LT) — RO. This bit indicates that the link points to a root port.
0	Link Valid (LV) — RO. When RPC.PC (offset 0224h, bits 1:0) is '01', '10', or '11', or FD.PE2D (offset 3418h, bit 17) is set, the link for this root port is not valid (return 0). When RPC.PC is '00' and FD.PE2D is cleared, the link for this root port is valid (return 1).

7.1.16 RP2BA—Root Port 2 Base Address Register

Offset Address: 0138–013Fh Attribute: RO
 Default Value: 00000000000E1000h Size: 64-bit

Bit	Description
63:32	Reserved
31:28	Reserved
27:20	Bus Number (BN) — RO. This field indicates the root port is on bus #0.
19:15	Device Number (DN) — RO. This field indicates the root port is on device #28.
14:12	Function Number (FN) — RO. This field indicates the root port is on function #1.
11:0	Reserved

7.1.17 RP3D—Root Port 3 Descriptor Register

Offset Address: 0140–0143h Attribute: R/WO, RO
 Default Value: 03xx0002h Size: 32-bit

Bit	Description
31:24	Target Port Number (PN) — RO. This field indicates the target port number is 3h (root port #3).
23:16	Target Component ID (TCID) — R/WO. This field returns the value of the ESD.CID (offset 0104h, bits 23:16) field programmed by platform BIOS, since the root port is in the same component as the RCRB.
15:2	Reserved
1	Link Type (LT) — RO. This bit indicates that the link points to a root port.
0	Link Valid (LV) — RO. When RPC.PC (offset 0224h, bits 1:0) is '11', or FD.PE3D (offset 3418h, bit 18) is set, the link for this root port is not valid (return 0). When RPC.PC is '00', '01', or '10', and FD.PE3D is cleared, the link for this root port is valid (return 1).

7.1.18 RP3BA—Root Port 3 Base Address Register

Offset Address: 0148–014Fh Attribute: RO
 Default Value: 00000000000E2000h Size: 64-bit

Bit	Description
63:32	Reserved
31:28	Reserved
27:20	Bus Number (BN) — RO. This field indicates the root port is on bus #0.
19:15	Device Number (DN) — RO. This field indicates the root port is on device #28.
14:12	Function Number (FN) — RO. This field indicates the root port is on function #2.
11:0	Reserved

7.1.19 RP4D—Root Port 4 Descriptor Register

Offset Address: 0150–0153h Attribute: R/WO, RO
 Default Value: 04xx0002h Size: 32-bit

Bit	Description
31:24	Target Port Number (PN) — RO. This field indicates the target port number is 4h (root port #4).
23:16	Target Component ID (TCID) — R/WO. This field returns the value of the ESD.CID (offset 0104h, bits 23:16) field programmed by platform BIOS, since the root port is in the same component as the RCRB.
15:2	Reserved
1	Link Type (LT) — RO. This bit indicates that the link points to a root port.
0	Link Valid (LV) — RO. When RPC.PC (offset 0224h, bits 1:0) is '10' or '11', or FD.PE4D (offset 3418h, bit 19) is set, the link for this root port is not valid (return 0). When RPC.PC is '00' or '01' and FD.PE4D is cleared, the link for this root port is valid (return 1).

7.1.20 RP4BA—Root Port 4 Base Address Register

Offset Address: 0158–015Fh Attribute: RO
 Default Value: 00000000000E3000h Size: 64-bit

Bit	Description
63:32	Reserved
31:28	Reserved
27:20	Bus Number (BN) — RO. This field indicates the root port is on bus #0.
19:15	Device Number (DN) — RO. This field indicates the root port is on device #28.
14:12	Function Number (FN) — RO. This field indicates the root port is on function #3.
11:0	Reserved

7.1.21 HDD—Intel® High Definition Audio Descriptor Register

Offset Address: 0160–0163h Attribute: R/WO, RO
 Default Value: 05xx0002h Size: 32-bit

Bit	Description
31:24	Target Port Number (PN) — RO. This field indicates the target port number is 5h (Intel High Definition Audio).
23:16	Target Component ID (TCID) — R/WO. This field returns the value of the ESD.CID (offset 0104h, bits 23:16) field programmed by platform BIOS, since the root port is in the same component as the RCRB.
15:2	Reserved
1	Link Type (LT) — RO. This bit indicates that the link points to a root port.
0	Link Valid (LV) — RO. When FD.ZD (offset 3418h, bit 4) is set, the link to Intel High Definition Audio is not valid (return 0). When FD.ZD is cleared, the link to Intel High Definition Audio is valid (return 1).

7.1.22 HDBA—Intel® High Definition Audio Base Address Register

Offset Address: 0168–016Fh Attribute: RO
 Default Value: 00000000000D8000h Size: 64-bit

Bit	Description
63:32	Reserved
31:28	Reserved
27:20	Bus Number (BN) — RO. This field indicates the root port is on bus #0.
19:15	Device Number (DN) — RO. This field indicates the root port is on device #27.
14:12	Function Number (FN) — RO. This field indicates the root port is on function #0.
11:0	Reserved

7.1.23 ILCL—Internal Link Capabilities List Register

Offset Address: 01A0–01A3h Attribute: RO
 Default Value: 00010006h Size: 32-bit

Bit	Description
31:20	Next Capability Offset (NEXT) — RO. This field indicates this is the last item in the list.
19:16	Capability Version (CV) — RO. This field indicates the version of the capability structure.
15:0	Capability ID (CID) — RO. This field indicates this is capability for DMI.

7.1.24 LCAP—Link Capabilities Register

Offset Address: 01A4–01A7h Attribute: RO, R/W
 Default Value: 00012441h Size: 32-bit

Bit	Description
31:18	Reserved
17:15	L1 Exit Latency (EL1) — L1 not supported on DMI.
14:12	L0s Exit Latency (EL0) — R/W. This field indicates that exit latency is 128 ns to less than 256 ns.
11:10	Active State Link PM Support (APMS) — R/W. This field indicates that L0s is supported on DMI.
9:4	Maximum Link Width (MLW) — This field indicates the maximum link width is 4 ports.
3:0	Maximum Link Speed (MLS) — This field indicates the link speed is 2.5 Gb/s.

7.1.25 LCTL—Link Control Register

Offset Address: 01A8–01A9h Attribute: R/W
 Default Value: 0000h Size: 16-bit

Bit	Description
15:8	Reserved
7	Extended Synch (ES) — R/W. When set, forces extended transmission of FTS ordered sets when exiting L0s prior to entering L0.
6:2	Reserved
1:0	Active State Link PM Control (APMC) — R/W. This field indicates whether DMI should enter L0s. 00 = Disabled 01 = L0s entry enabled 10 = Reserved 11 = Reserved

7.1.26 LSTS—Link Status Register

Offset Address: 01AA–01ABh Attribute: RO
 Default Value: 0041h Size: 16-bit

Bit	Description
15:10	Reserved
9:4	Negotiated Link Width (NLW) — RO. Negotiated link width is x4 (000100b). ICH6-M may also indicate x2 (000010b), depending on (G)MCH configuration.
3:0	Link Speed (LS) — RO. Link is 2.5 Gb/s.

7.1.27 CSIR5—Chipset Initialization Register 5

Offset Address: 0200–0203h Attribute: R/W
 Default Value: 01100220h Size: 32-bit

Bit	Description
31:14	Reserved
13:8	Chipset Initialization Register Bits[13:8] — R/W. BIOS programs this field to 100000b.
7:6	Reserved
5:0	Chipset Initialization Register Bits[5:0] — R/W. BIOS programs this field to 001000b.

7.1.28 CSIR6—Chipset Initialization Register 6

Offset Address: 020C–020Fh Attribute: R/W
 Default Value: 00201004h Size: 32-bit

Bit	Description
31:22	Reserved
21:16	Chipset Initialization Register Bits[21:16] — R/W. BIOS programs this field to 000100b.
15:14	Reserved
13:8	Chipset Initialization Register Bits[13:8] — R/W. BIOS programs this field to 000010b.
7:6	Reserved
5:0	Chipset Initialization Register Bits[5:0] — R/W. BIOS programs this field to 000001b.

7.1.29 BCR—Backbone Configuration Register

Offset Address: 0220–0223h Attribute: R/W
 Default Value: 000008000h Size: 32-bit

Bit	Description
31:8	Reserved
7:5	Backbone Configuration Register Bits[8:5] — R/W. BIOS sets this field to 111b.
4	Reserved
3:0	Backbone Configuration Register Bits[3:0] — R/W. BIOS sets this field to 0101b.

7.1.30 RPC—Root Port Configuration Register

Offset Address: 0224–0227h Attribute: R/W, RO
 Default Value: 0000000xh Size: 32-bit

Bit	Description
31:8	Reserved
7	High Priority Port Enable (HPE) — R/W. 0 = The high priority path is not enabled. 1 = The port selected by the HPP field in this register is enabled for high priority. It will be arbitrated above all other VC0 (including integrated VC0) devices.
6	Reserved
5:4	High Priority Port (HPP) — R/W. This field controls which port is enabled for high priority when the HPE bit in this register is set. 11 = Port 4 10 = Port 3 01 = Port 2 00 = Port 1
3:2	Reserved
1:0	Port Configuration (PC) — RO. This field controls how the PCI bridges are organized in various modes of operation. For the following mappings, if a port is not shown, it is considered a x1 port with no connection. These bits represent the strap values of ACZ_SDOUT (bit 1) and ACZ_SYNC (bit 0) when TP[3] is not pulled low at the rising edge of PWROK. 11 = 1 x4, Port 1 (x4) (Enterprise applications only) 10 = Reserved 01 = Reserved 00 = 4 x1s, Port 1 (x1), Port 2 (x1), Port 3 (x1), Port 4 (x1) These bits live in the resume well and are only reset by RSMRST#.

7.1.31 CSIR7—Chipset Initialization Register 7

Offset Address: 1D40–1D43h Attribute: R/W
 Default Value: 00000000h Size: 32-bit

Bit	Description
31:1	Reserved
0	Chipset Initialization Register 7 Bit[0] — R/W. BIOS sets this bit to 1.

7.1.32 TRSR—Trap Status Register

Offset Address: 1E00–1E03h Attribute: R/WC, RO
 Default Value: 00000000h Size: 32-bit

Bit	Description
31:4	Reserved
3:0	<p>Cycle Trap SMI# Status (CTSS) — R/WC. These bits are set by hardware when the corresponding Cycle Trap register is enabled and a matching cycle is received (and trapped). These bits are OR'ed together to create a single status bit in the Power Management register space.</p> <p>Note that the SMI# and trapping must be enabled in order to set these bits.</p> <p>These bits are set before the completion is generated for the trapped cycle, thereby guaranteeing that the processor can enter the SMI# handler when the instruction completes. Each status bit is cleared by writing a 1 to the corresponding bit location in this register.</p>

7.1.33 TRCR—Trapped Cycle Register

Offset Address: 1E10–1E17h Attribute: RO
 Default Value: 0000000000000000h Size: 64-bit

This register saves information about the I/O Cycle that was trapped and generated the SMI# for software to read.

Bit	Description
63:25	Reserved
24	<p>Read/Write# (RWI) — RO.</p> <p>0 = Trapped cycle was a write cycle. 1 = Trapped cycle was a read cycle.</p>
23:20	Reserved
19:16	<p>Active-high Byte Enables (AHBE) — RO. This is the DWord-aligned byte enables associated with the trapped cycle. A 1 in any bit location indicates that the corresponding byte is enabled in the cycle.</p>
15:2	<p>Trapped I/O Address (TIOA) — RO. This is the DWord-aligned address of the trapped cycle.</p>
1:0	Reserved

7.1.34 TWDR—Trapped Write Data Register

Offset Address: 1E18–1E1Fh Attribute: RO
 Default Value: 0000000000000000h Size: 64-bit

This register saves the data from I/O write cycles that are trapped for software to read.

Bit	Description
63:32	Reserved
31:0	Trapped I/O Data (TIOD) — RO. DWord of I/O write data. This field is undefined after trapping a read cycle.

7.1.35 IOTRn—I/O Trap Register(0:3)

Offset Address: 1E80–1E87h Register 0 Attribute: R/W, RO
 1E88–1E8Fh Register 1
 1E90–1E97h Register 2
 1E98–1E9Fh Register 3
 Default Value: 0000000000000000h Size: 64-bit

These registers are used to specify the set of I/O cycles to be trapped and to enable this functionality.

Bit	Description
63:50	Reserved
49	Read/Write Mask (RWM) — R/W. 0 = The cycle must match the type specified in bit 48. 1 = Trapping logic will operate on both read and write cycles.
48	Read/Write# (RWIO) — R/W. 0 = Write 1 = Read NOTE: The value in this field does not matter if bit 49 is set.
47:40	Reserved
39:36	Byte Enable Mask (BEM) — R/W. A 1 in any bit position indicates that any value in the corresponding byte enable bit in a received cycle will be treated as a match. The corresponding bit in the Byte Enables field, below, is ignored.
35:32	Byte Enables (TBE) — R/W. Active-high DWord-aligned byte enables.
31:24	Reserved
23:18	Address[7:2] Mask (ADMA) — R/W. A 1 in any bit position indicates that any value in the corresponding address bit in a received cycle will be treated as a match. The corresponding bit in the Address field, below, is ignored. The mask is only provided for the lower 6 bits of the DWord address, allowing for traps on address ranges up to 256 bytes in size.
17:16	Reserved
15:2	I/O Address[15:2] (IOAD) — R/W. DWord-aligned address
1	Reserved
0	Trap and SMI# Enable (TRSE) — R/W. 0 = Trapping and SMI# logic disabled. 1 = The trapping logic specified in this register is enabled.

7.1.36 DMC—DMI Miscellaneous Control Register (Mobile Only)

Offset Address: 2010–2013h Attribute: R/W
 Default Value: N/A Size: 32-bit

Bit	Description
31:2	Reserved
1	DMI Misc. Control Field 1 — R/W. BIOS shall always program this field as per the BIOS Specification. 0 = Disable DMI Power Savings. 1 = Enable DMI Power Savings.
0	Reserved

7.1.37 CSCR1—Chipset Configuration Register 1

Offset Address: 2020–2023h Attribute: R/W
 Default Value: 00C4B0DBh Size: 32-bits

Bit	Description
31:28	Chipset Configuration Register 1 Bits[31:28] — R/W. Refer to the ICH6 BIOS Specification for the programming of this field.
27:9	Reserved
8:6	Chipset Configuration Register 1 Bits[8:6] — R/W. BIOS programs this field to 001b.
5:0	Reserved

7.1.38 CSCR2—Chipset Configuration Register 2

Offset Address: 2027h Attribute: R/W
 Default Value: 0Ah Size: 8-bits

Bit	Description
7:0	Chipset Configuration Register 2 Bits[7:0] — R/W. BIOS programs this field to 0Dh.

7.1.39 PLLMC—PLL Miscellaneous Control Register (Mobile Only)

Offset Address: 2078–207Bh Attribute: R/W
 Default Value: N/A Size: 32-bit

Bit	Description
31:25	Reserved
24	PLL Misc. Control Field 2 — R/W. BIOS shall always program this field as per the BIOS Specification. 0 = Disable Clock Gating. 1 = Enable Clock Gating..
23	Reserved
22	PLL Misc. Control Field 1 — R/W. BIOS shall always program this field as per the BIOS Specification. 0 = Disable Clock Gating. 1 = Enable Clock Gating..
21:0	Reserved

7.1.40 TCTL—TCO Configuration Register

Offset Address: 3000–3000h Attribute: R/W
 Default Value: 00h Size: 8-bit

Bit	Description
7	TCO IRQ Enable (IE) — R/W. 0 = TCO IRQ is disabled. 1 = TCO IRQ is enabled, as selected by the TCO_IRQ_SEL field.
6:3	Reserved
2:0	TCO IRQ Select (IS) — R/W. This field specifies on which IRQ the TCO will internally appear. If not using the APIC, the TCO interrupt must be routed to IRQ9:11, and that interrupt is not sharable with the SERIRQ stream, but is shareable with other PCI interrupts. If using the APIC, the TCO interrupt can also be mapped to IRQ20:23, and can be shared with other interrupt. 000 = IRQ 9 001 = IRQ 10 010 = IRQ 11 011 = Reserved 100 = IRQ 20 (only if APIC enabled) 101 = IRQ 21 (only if APIC enabled) 110 = IRQ 22 (only if APIC enabled) 111 = IRQ 23 (only if APIC enabled) When setting the these bits, the IE bit should be cleared to prevent glitching. When the interrupt is mapped to APIC interrupts 9, 10 or 11, the APIC should be programmed for active-high reception. When the interrupt is mapped to APIC interrupts 20 through 23, the APIC should be programmed for active-low reception.

7.1.41 D31IP—Device 31 Interrupt Pin Register

Offset Address: 3100–3103h Attribute: R/W, RO
 Default Value: 00042210h Size: 32-bit

Bit	Description
31:16	Reserved
15:12	<p>SM Bus Pin (SMIP) — R/W. This field indicates which pin the SMBus controller drives as its interrupt.</p> <p>0h = No interrupt 1h = INTA# 2h = INTB# (Default) 3h = INTC# 4h = INTD# 5h–7h = Reserved</p>
11:8	<p>SATA Pin (SIP) — R/W. This field indicates which pin the SATA controller drives as its interrupt.</p> <p>0h = No interrupt 1h = INTA# 2h = INTB# (Default) 3h = INTC# 4h = INTD# 5h–7h = Reserved</p>
7:4	<p>PATA Pin (SMIP) — R/W. This field indicates which pin the PATA controller drives as its interrupt.</p> <p>0h = No interrupt 1h = INTA# (Default) 2h = INTB# 3h = INTC# 4h = INTD# 5h–7h = Reserved</p>
3:0	<p>PCI Bridge Pin (PIP) — RO. Currently, the PCI bridge does not generate an interrupt, so this field is read-only and 0.</p>

7.1.42 D30IP—Device 30 Interrupt Pin Register

Offset Address: 3104–3107h Attribute: R/W, RO
 Default Value: 00002100h Size: 32-bit

Bit	Description
31:16	Reserved
15:12	<p>AC '97 Modem Pin (AMIP) — R/W. This field indicates which pin the AC '97 Modem controller drives as its interrupt.</p> <p>0h = No interrupt 1h = INTA# 2h = INTB# (Default) 3h = INTC# 4h = INTD# 5h–7h = Reserved</p>
11:8	<p>AC '97 Audio Pin (AAIP) — R/W. This field indicates which pin the AC '97 audio controller drives as its interrupt.</p> <p>0h = No interrupt 1h = INTA# (Default) 2h = INTB# 3h = INTC# 4h = INTD# 5h–7h = Reserved</p>
7:4	Reserved
3:0	LPC Bridge Pin (LIP) — RO. Currently, the LPC bridge does not generate an interrupt, so this field is read-only and 0.

7.1.43 D29IP—Device 29 Interrupt Pin Register

Offset Address: 3108–310Bh Attribute: R/W
 Default Value: 10004321h Size: 32-bit

Bit	Description
31:28	EHCI Pin (EIP) — R/W. This field indicates which pin the EHCI controller drives as its interrupt. 0h = No interrupt 1h = INTA# (Default) 2h = INTB# 3h = INTC# 4h = INTD# 5h–7h = Reserved
27:16	Reserved
15:12	UHCI #3 Pin (U3P) — R/W. This field indicates which pin the UHCI controller #3 (ports 6 and 7) drives as its interrupt. 0h = No interrupt 1h = INTA# 2h = INTB# 3h = INTC# 4h = INTD# (Default) 5h–7h = Reserved
11:8	UHCI #2 Pin (U2P) — R/W. This field indicates which pin the UHCI controller #2 (ports 4 and 5) drives as its interrupt. 0h = No interrupt 1h = INTA# 2h = INTB# 3h = INTC# (Default) 4h = INTD# 5h–7h = Reserved
7:4	UHCI #1 Pin (U1P) — R/W. This field indicates which pin the UHCI controller #1 (ports 2 and 3) drives as its interrupt. 0h = No interrupt 1h = INTA# 2h = INTB# (Default) 3h = INTC# 4h = INTD# 5h–7h = Reserved
3:0	UHCI #0 Pin (U0P) — R/W. This field indicates which pin the UHCI controller #0 (ports 0 and 1) drives as its interrupt. 0h = No interrupt 1h = INTA# (Default) 2h = INTB# 3h = INTC# 4h = INTD# 5h–7h = Reserved

7.1.44 D28IP—Device 28 Interrupt Pin Register

Offset Address: 310C–310Fh Attribute: R/W
 Default Value: 00004321h Size: 32-bit

Bit	Description
31:16	Reserved
15:12	PCI Express #4 Pin (P4IP) — R/W. This field indicates which pin the PCI Express* port #4 drives as its interrupt. 0h = No interrupt 1h = INTA# 2h = INTB# 3h = INTC# 4h = INTD# (Default) 5h–7h = Reserved
11:8	PCI Express #3 Pin (P3IP) — R/W. This field indicates which pin the PCI Express port #3 drives as its interrupt. 0h = No interrupt 1h = INTA# 2h = INTB# 3h = INTC# (Default) 4h = INTD# 5h–7h = Reserved
7:4	PCI Express #2 Pin (P2IP) — R/W. This field indicates which pin the PCI Express port #2 drives as its interrupt. 0h = No interrupt 1h = INTA# 2h = INTB# (Default) 3h = INTC# 4h = INTD# 5h–7h = Reserved
3:0	PCI Express #1 Pin (P1IP) — R/W. This field indicates which pin the PCI Express port #1 drives as its interrupt. 0h = No interrupt 1h = INTA# (Default) 2h = INTB# 3h = INTC# 4h = INTD# 5h–7h = Reserved

7.1.45 D27IP—Device 27 Interrupt Pin Register

Offset Address: 3110–3113h Attribute: R/W
 Default Value: 00000001h Size: 32-bit

Bit	Description
31:4	Reserved
3:0	Intel High Definition Audio Pin (ZIP) — R/W. This field indicates which pin the Intel High Definition Audio controller drives as its interrupt. 0h = No interrupt 1h = INTA# (Default) 2h = INTB# 3h = INTC# 4h = INTD# 5h–7h = Reserved

7.1.46 D31IR—Device 31 Interrupt Route Register

Offset Address: 3140–3141h
 Default Value: 3210h

Attribute: R/W
 Size: 16-bit

Bit	Description
15	Reserved
14:12	<p>Interrupt D Pin Route (IDR) — R/W. This field indicates which physical pin on the Intel® ICH6 is connected to the INTD# pin reported for device 31 functions.</p> <p>0h = PIRQA# 1h = PIRQB# 2h = PIRQC# 3h = PIRQD# (Default) 4h = PIRQE# 5h = PIRQF# 6h = PIRQG# 7h = PIRQH#</p>
11	Reserved
10:8	<p>Interrupt C Pin Route (ICR) — R/W. This field indicates which physical pin on the ICH is connected to the INTC# pin reported for device 31 functions.</p> <p>0h = PIRQA# 1h = PIRQB# 2h = PIRQC# (Default) 3h = PIRQD# 4h = PIRQE# 5h = PIRQF# 6h = PIRQG# 7h = PIRQH#</p>
7	Reserved
6:4	<p>Interrupt B Pin Route (IBR) — R/W. This field indicates which physical pin on the ICH is connected to the INTB# pin reported for device 31 functions.</p> <p>0h = PIRQA# 1h = PIRQB# (Default) 2h = PIRQC# 3h = PIRQD# 4h = PIRQE# 5h = PIRQF# 6h = PIRQG# 7h = PIRQH#</p>
3	Reserved
2:0	<p>Interrupt A Pin Route (IAR) — R/W. This field indicates which physical pin on the ICH is connected to the INTA# pin reported for device 31 functions.</p> <p>0h = PIRQA# (Default) 1h = PIRQB# 2h = PIRQC# 3h = PIRQD# 4h = PIRQE# 5h = PIRQF# 6h = PIRQG# 7h = PIRQH#</p>



7.1.47 D30IR—Device 30 Interrupt Route Register

Offset Address: 3142–3143h
 Default Value: 3210h

Attribute: R/W
 Size: 16-bit

Bit	Description
15	Reserved
14:12	<p>Interrupt D Pin Route (IDR) — R/W. This field indicates which physical pin on the Intel[®] ICH6 is connected to the INTD# pin reported for device 30 functions.</p> <p>0h = PIRQA# 1h = PIRQB# 2h = PIRQC# 3h = PIRQD# (Default) 4h = PIRQE# 5h = PIRQF# 6h = PIRQG# 7h = PIRQH#</p>
11	Reserved
10:8	<p>Interrupt C Pin Route (ICR) — R/W. This field indicates which physical pin on the ICH is connected to the INTC# pin reported for device 30 functions.</p> <p>0h = PIRQA# 1h = PIRQB# 2h = PIRQC# (Default) 3h = PIRQD# 4h = PIRQE# 5h = PIRQF# 6h = PIRQG# 7h = PIRQH#</p>
7	Reserved
6:4	<p>Interrupt B Pin Route (IBR) — R/W. This field indicates which physical pin on the ICH is connected to the INTB# pin reported for device 30 functions.</p> <p>0h = PIRQA# 1h = PIRQB# (Default) 2h = PIRQC# 3h = PIRQD# 4h = PIRQE# 5h = PIRQF# 6h = PIRQG# 7h = PIRQH#</p>
3	Reserved
2:0	<p>Interrupt A Pin Route (IAR) — R/W. This field indicates which physical pin on the ICH is connected to the INTA# pin reported for device 30 functions.</p> <p>0h = PIRQA# (Default) 1h = PIRQB# 2h = PIRQC# 3h = PIRQD# 4h = PIRQE# 5h = PIRQF# 6h = PIRQG# 7h = PIRQH#</p>

7.1.48 D29IR—Device 29 Interrupt Route Register

Offset Address: 3144–3145h
 Default Value: 3210h

Attribute: R/W
 Size: 16-bit

Bit	Description
15	Reserved
14:12	<p>Interrupt D Pin Route (IDR) — R/W. This field indicates which physical pin on the Intel® ICH6 is connected to the INTD# pin reported for device 29 functions.</p> <p>0h = PIRQA# 1h = PIRQB# 2h = PIRQC# 3h = PIRQD# (Default) 4h = PIRQE# 5h = PIRQF# 6h = PIRQG# 7h = PIRQH#</p>
11	Reserved
10:8	<p>Interrupt C Pin Route (ICR) — R/W. This field indicates which physical pin on the ICH6 is connected to the INTC# pin reported for device 29 functions.</p> <p>0h = PIRQA# 1h = PIRQB# 2h = PIRQC# (Default) 3h = PIRQD# 4h = PIRQE# 5h = PIRQF# 6h = PIRQG# 7h = PIRQH#</p>
7	Reserved
6:4	<p>Interrupt B Pin Route (IBR) — R/W. This field indicates which physical pin on the ICH is connected to the INTB# pin reported for device 29 functions.</p> <p>0h = PIRQA# 1h = PIRQB# (Default) 2h = PIRQC# 3h = PIRQD# 4h = PIRQE# 5h = PIRQF# 6h = PIRQG# 7h = PIRQH#</p>
3	Reserved
2:0	<p>Interrupt A Pin Route (IAR) — R/W. This field indicates which physical pin on the ICH6 is connected to the INTA# pin reported for device 29 functions.</p> <p>0h = PIRQA# (Default) 1h = PIRQB# 2h = PIRQC# 3h = PIRQD# 4h = PIRQE# 5h = PIRQF# 6h = PIRQG# 7h = PIRQH#</p>

7.1.49 D28IR—Device 28 Interrupt Route Register

Offset Address: 3146–3147h Attribute: R/W
 Default Value: 3210h Size: 16-bit

Bit	Description
15	Reserved
14:12	Interrupt D Pin Route (IDR) — R/W. This field indicates which physical pin on the Intel [®] ICH6 is connected to the INTD# pin reported for device 28 functions. 0h = PIRQA# 1h = PIRQB# 2h = PIRQC# 3h = PIRQD# (Default) 4h = PIRQE# 5h = PIRQF# 6h = PIRQG# 7h = PIRQH#
11	Reserved
10:8	Interrupt C Pin Route (ICR) — R/W. This field indicates which physical pin on the ICH is connected to the INTC# pin reported for device 28 functions. 0h = PIRQA# 1h = PIRQB# 2h = PIRQC# (Default) 3h = PIRQD# 4h = PIRQE# 5h = PIRQF# 6h = PIRQG# 7h = PIRQH#
7	Reserved
6:4	Interrupt B Pin Route (IBR) — R/W. This field indicates which physical pin on the ICH is connected to the INTB# pin reported for device 28 functions. 0h = PIRQA# 1h = PIRQB# (Default) 2h = PIRQC# 3h = PIRQD# 4h = PIRQE# 5h = PIRQF# 6h = PIRQG# 7h = PIRQH#
3	Reserved
2:0	Interrupt A Pin Route (IAR) — R/W. This field indicates which physical pin on the ICH is connected to the INTA# pin reported for device 28 functions. 0h = PIRQA# (Default) 1h = PIRQB# 2h = PIRQC# 3h = PIRQD# 4h = PIRQE# 5h = PIRQF# 6h = PIRQG# 7h = PIRQH#

7.1.50 D27IR—Device 27 Interrupt Route Register

Offset Address: 3148–3149h
 Default Value: 3210h

Attribute: R/W
 Size: 16-bit

Bit	Description
15	Reserved
14:12	<p>Interrupt D Pin Route (IDR) — R/W. This field indicates which physical pin on the Intel® ICH6 is connected to the INTD# pin reported for device 27 functions.</p> <p>0h = PIRQA# 1h = PIRQB# 2h = PIRQC# 3h = PIRQD# (Default) 4h = PIRQE# 5h = PIRQF# 6h = PIRQG# 7h = PIRQH#</p>
11	Reserved
10:8	<p>Interrupt C Pin Route (ICR) — R/W. This field indicates which physical pin on the ICH is connected to the INTC# pin reported for device 27 functions.</p> <p>0h = PIRQA# 1h = PIRQB# 2h = PIRQC# (Default) 3h = PIRQD# 4h = PIRQE# 5h = PIRQF# 6h = PIRQG# 7h = PIRQH#</p>
7	Reserved
6:4	<p>Interrupt B Pin Route (IBR) — R/W. This field indicates which physical pin on the ICH is connected to the INTB# pin reported for device 27 functions.</p> <p>0h = PIRQA# 1h = PIRQB# (Default) 2h = PIRQC# 3h = PIRQD# 4h = PIRQE# 5h = PIRQF# 6h = PIRQG# 7h = PIRQH#</p>
3	Reserved
2:0	<p>Interrupt A Pin Route (IAR) — R/W. This field indicates which physical pin on the ICH is connected to the INTA# pin reported for device 27 functions.</p> <p>0h = PIRQA# (Default) 1h = PIRQB# 2h = PIRQC# 3h = PIRQD# 4h = PIRQE# 5h = PIRQF# 6h = PIRQG# 7h = PIRQH#</p>

7.1.51 OIC—Other Interrupt Control Register

Offset Address: 31FF–31FFh Attribute: R/W
 Default Value: 00h Size: 8-bit

Bit	Description
7:2	Reserved
1	Coprocessor Error Enable (CEN) — R/W. 0 = FERR# will not generate IRQ13 nor IGNNE#. 1 = If FERR# is low, the Intel® ICH6 generates IRQ13 internally and holds it until an I/O port F0h write. It will also drive IGNNE# active.
0	APIC Enable (AEN) — R/W. 0 = The internal IOxAPIC is disabled. 1 = Enables the internal IOxAPIC and its address decode.

7.1.52 RC—RTC Configuration Register

Offset Address: 3400–3403h Attribute: R/W, R/WLO
 Default Value: 00000000h Size: 32-bit

Bit	Description
31:5	Reserved
4	Upper 128 Byte Lock (UL) — R/WLO. 0 = Bytes not locked. 1 = Bytes 38h–3Fh in the upper 128-byte bank of RTC RAM are locked and cannot be accessed. Writes will be dropped and reads will not return any guaranteed data. Bit reset on system reset.
3	Lower 128 Byte Lock (LL) — R/WLO. 0 = Bytes not locked. 1 = Bytes 38h–3Fh in the lower 128-byte bank of RTC RAM are locked and cannot be accessed. Writes will be dropped and reads will not return any guaranteed data. Bit reset on system reset.
2	Upper 128 Byte Enable (UE) — R/W. 0 = Bytes locked. 1 = The upper 128-byte bank of RTC RAM can be accessed.
1:0	Reserved

7.1.53 HPTC—High Precision Timer Configuration Register

Offset Address: 3404–3407h Attribute: R/W
 Default Value: 00000000h Size: 32-bit

Bit	Description
31:8	Reserved
7	Address Enable (AE) — R/W. 0 = Address disabled. 1 = The Intel® ICH6 will decode the High Precision Timer memory address range selected by bits 1:0 below.
6:2	Reserved
1:0	Address Select (AS) — R/W. This 2-bit field selects 1 of 4 possible memory address ranges for the High Precision Timer functionality. The encodings are: 00 = FED0_0000h–FED0_03FFh 01 = FED0_1000h–FED0_13FFh 10 = FED0_2000h–FED0_23FFh 11 = FED0_3000h–FED0_33FFh

7.1.54 GCS—General Control and Status Register

Offset Address: 3410–3413h Attribute: R/W, R/WLO
 Default Value: 0000000yh y=(00x0x000b) Size: 32-bit

Bit	Description
31:10	Reserved
9	Server Error Reporting Mode (SERM) — R/W. 0 = The Intel® ICH6 is the final target of all errors. The (G)MCH sends a messages to the ICH for the purpose of generating NMI. 1 = The (G)MCH is the final target of all errors from PCI Express* and DMI. In this mode, if the ICH6 detects a fatal, non-fatal, or correctable error on DMI or its downstream ports, it sends a message to the (G)MCH. If the ICH6 receives an ERR_* message from the downstream port, it sends that message to the (G)MCH.
8	Reserved
7 (Mobile)	Mobile IDE Configuration Lock Down (MICLD) — R/WLO. 0 = Disabled. 1 = BUC.PRS (offset 3414h, bit 1) is locked and cannot be written until a system reset occurs. This prevents rogue software from changing the default state of the PATA pins during boot after BIOS configures them. This bit is write once, and is cleared by system reset and when returning from the S3/S4/S5 states.
7 (Desktop)	Reserved
6	FERR# MUX Enable (FME) — R/W. This bit enables FERR# to be a processor break event indication. 0 = Disabled. 1 = The ICH6 examines FERR# during a C2, C3, or C4 state as a break event. See Chapter 5.14.5 for a functional description.

Bit	Description
5	<p>No Reboot (NR) — R/W. This bit is set when the “No Reboot” strap (SPKR pin on ICH6) is sampled high on PWROK. This bit may be set or cleared by software if the strap is sampled low but may not override the strap when it indicates “No Reboot”.</p> <p>0 = System will reboot upon the second timeout of the TCO timer. 1 = The TCO timer will count down and generate the SMI# on the first timeout, but will not reboot on the second timeout.</p>
4	<p>Alternate Access Mode Enable (AME) — R/W.</p> <p>0 = Disabled. 1 = Alternate access read only registers can be written, and write only registers can be read. Before entering a low power state, several registers from powered down parts may need to be saved. In the majority of cases, this is not an issue, as registers have read and write paths. However, several of the ISA compatible registers are either read only or write only. To get data out of write-only registers, and to restore data into read-only registers, the ICH implements an alternate access mode. For a list of these registers see Section 5.14.10.</p>
3	<p>Boot BIOS Destination (BBD) — R/W. The default value of this bit is determined by a strap allowing systems with corrupted or unprogrammed flash to boot from a PCI device. The value of the strap can be overwritten by software.</p> <p>When this bit is 0, the PCI-to-PCI bridge memory space enable bit does not need to be set (nor any other bits) in order for these cycles to go to PCI. Note that BIOS enable ranges and the other BIOS protection and update bits associated with the FWH interface have no effect when this bit is 0.</p> <p>0 = The top 16 MB of memory below 4 GB (FF00_0000h to FFFF_FFFFh) is accepted by the primary side of the PCI P2P bridge and forwarded to the PCI bus. 1 = The top 16 MB of memory below 4 GB (FF00_0000h to FFFF_FFFFh) is not decoded to PCI and the LPC bridge claims these cycles based on the FWH Decode Enable bits.</p> <p>NOTE: This functionality intended for debug/testing only.</p>
2	<p>Reserved Page Route (RPR) — R/W. Determines where to send the reserved page registers. These addresses are sent to PCI or LPC for the purpose of generating POST codes. The I/O addresses modified by this field are: 80h, 84h, 85h, 86h, 88h, 8Ch, 8Dh, and 8Eh.</p> <p>0 = Writes will be forwarded to LPC, shadowed within the ICH, and reads will be returned from the internal shadow 1 = Writes will be forwarded to PCI, shadowed within the ICH, and reads will be returned from the internal shadow.</p> <p>Note, if some writes are done to LPC/PCI to these I/O ranges, and then this bit is flipped, such that writes will now go to the other interface, the reads will not return what was last written. Shadowing is performed on each interface.</p> <p>The aliases for these registers, at 90h, 94h, 95h, 96h, 98h, 9Ch, 9Dh, and 9Eh, are always decoded to LPC.</p>
1	Reserved
0	<p>Top Swap Lock-Down (TSLD) — R/WLO.</p> <p>0 = Disabled. 1 = Prevents BUC.TS (offset 3414, bit 0) from being changed. This bit can only be written from 0 to 1 once.</p>

7.1.55 BUC—Backed Up Control Register

Offset Address: 3414–3414h Attribute: R/W
 Default Value: 0000001xb (Mobile) Size: 8-bit
 0000000xb (Desktop)

All bits in this register are in the RTC well and only cleared by RTCRST#

Bit	Description
7:3	Reserved
2	CPU BIST Enable (CBE) — R/W. This bit is in the resume well and is reset by RSMRST#, but not PLTRST# nor CF9h writes. 0 = Disabled. 1 = The INIT# signals will be driven active when CPURST# is active. INIT# and INIT3_3V# will go inactive with the same timings as the other processor I/F signals (hold time after CPURST# inactive).
1 (Mobile)	PATA Reset State (PRS) — R/W. 0 = The reset state of the PATA pins will be driven. 1 = The reset state of the PATA pins will be tri-state.
1 (Desktop)	Reserved
0	Top Swap (TS) — R/W. 0 = Intel® ICH6 will not invert A16. 1 = ICH6 will invert A16 for cycles going to the BIOS space (but not the feature space) in the FWH. If ICH is strapped for Top-Swap (GNT[6]# is low at rising edge of PWROK), then this bit cannot be cleared by software. The strap jumper should be removed and the system rebooted.

7.1.56 FD—Function Disable Register

Offset Address: 3418–341Bh Attribute: R/W, RO
 Default Value: See bit description Size: 32-bit

The UHCI functions must be disabled from highest function number to lowest. For example, if only three UHCIs are wanted, software must disable UHCI #4 (UD4 bit set). When disabling UHCIs, the EHCI Structural Parameters Registers must be updated with coherent information in “Number of Companion Controllers” and “N_Ports” fields.

When disabling a function, only the configuration space is disabled. Software must ensure that all functionality within a controller that is not desired (such as memory spaces, I/O spaces, and DMA engines) is disabled prior to disabling the function.

When a function is disabled, software must not attempt to re-enable it. A disabled function can only be re-enabled by a platform reset.

Bit	Description
31:20	Reserved
19	PCI Express 4 Disable (PE4D) — R/W. Default is 0. When disabled, the link for this port is put into the “link down” state. 0 = PCI Express* port #4 is enabled. 1 = PCI Express port #4 is disabled.
18	PCI Express 3 Disable (PE3D) — R/W. Default is 0. When disabled, the link for this port is put into the link down state. 0 = PCI Express port #3 is enabled. 1 = PCI Express port #3 is disabled.
17	PCI Express 2 Disable (PE2D) — R/W. Default is 0. When disabled, the link for this port is put into the link down state. 0 = PCI Express port #2 is enabled. 1 = PCI Express port #2 is disabled.
16	PCI Express 1 Disable (PE1D) — R/W. Default is 0. When disabled, the link for this port is put into the link down state. 0 = PCI Express port #1 is enabled. 1 = PCI Express port #1 is disabled.
15	EHCI Disable (EHCID) — R/W. Default is 0. 0 = The EHCI is enabled. 1 = The EHCI is disabled.
14	LPC Bridge Disable (LBD) — R/W. Default is 0. 0 = The LPC bridge is enabled. 1 = The LPC bridge is disabled. Unlike the other disables in this register, the following additional spaces will no longer be decoded by the LPC bridge: <ul style="list-style-type: none"> • Memory cycles below 16 MB (1000000h) • I/O cycles below 64 kB (10000h) • The Internal I/OxAPIC at FEC0_0000 to FECF_FFFF Memory cycles in the LPC BIOS range below 4 GB will still be decoded when this bit is set, but the aliases at the top of 1 MB (the E and F segment) no longer will be decoded.
13:12	Reserved
11	UHCI #4 Disable (U4D) — R/W. Default is 0. 0 = The 4th UHCI (ports 6 and 7) is enabled. 1 = The 4th UHCI (ports 6 and 7) is disabled.
10	UHCI #3 Disable (U3D) — R/W. Default is 0. 0 = The 3rd UHCI (ports 4 and 5) is enabled. 1 = The 3rd UHCI (ports 4 and 5) is disabled.

Bit	Description
9	UHCI #2 Disable (U2D) — R/W. Default is 0. 0 = The 2nd UHCI (ports 2 and 3) is enabled. 1 = The 2nd UHCI (ports 2 and 3) is disabled.
8	UHCI #1 Disable (U1D) — R/W. Default is 0. 0 = The 1st UHCI (ports 0 and 1) is enabled. 1 = The 1st UHCI (ports 0 and 1) is disabled.
7	Hide Internal LAN (HIL) — R/W. Default is 0. 0 = The LAN controller is enabled. 1 = The LAN controller is disabled and will not decode configuration cycles off of PCI.
6	AC '97 Modem Disable (AMD) — R/W. Default is 0. 0 = The AC '97 modem function is enabled. 1 = The AC '97 modem function is disabled.
5	AC '97 Audio Disable (AAD) — R/W. Default is 0. 0 = The AC '97 audio function is enabled. 1 = The AC '97 audio function is disabled.
4	Intel High Definition Audio Disable (ZD) — R/W. Default is 0. 0 = The Intel High Definition Audio controller is enabled. 1 = The Intel High Definition Audio controller is disabled and its PCI configuration space is not accessible.
3	SM Bus Disable (SD) — R/W. Default is 0. 0 = The SM Bus controller is enabled. 1 = The SM Bus controller is disabled. In ICH5 and previous, this also disabled the I/O space. In ICH6, it only disables the configuration space.
2	Serial ATA Disable (SAD) — R/W. Default is 0. 0 = The SATA controller is enabled. 1 = The SATA controller is disabled.
1	Parallel ATA Disable (PAD) — R/W. Default is 0. 0 = The PATA controller is enabled. 1 = The PATA controller is disabled and its PCI configuration space is not accessible.
0	Reserved

7.1.57 CG—Clock Gating

Offset Address: 341C–341Fh
Default Value: 00000000h

Attribute: R/W, RO
Size: 32-bit

Bit	Description
31:1	Reserved
0	PCI Express root port Static Clock Gate Enable (PESCG) — R/W. 0 = Static Clock Gating is Disabled for the PCI Express* root port. 1 = Static Clock Gating is Enabled for the PCI Express root port when the corresponding port is disabled in the Function Disable register (Chipset Configuration Registers:Offset 3418h) FD.PE1D, FD.PE2D, FD.PE3D or FD.PE4D. In addition to the PCI Express function disable register, the PCI Express root port physical layer static clock gating is also qualified by the Root Port Configuration RPC.PC (Chipset Configuration Registers:Offset 0224h:bits 1:0) as the physical layer may be required by an enabled port in a x4 configuration.

7.1.58 CSIR1—Chipset Initialization Register 1

Offset Address: 3E08–3E09h Attribute: R/W
 Default Value: 0000h Size: 16-bits

Bit	Description
15:8	Reserved
7	Chipset Initialization Register 1 Bit[7] — R/W. BIOS sets this bit to 1.
6:0	Reserved

7.1.59 CSIR2—Chipset Initialization Register 2

Offset Address: 3E48–3E49h Attribute: R/W
 Default Value: 0000h Size: 16-bits

Bit	Description
15:8	Reserved
7	Chipset Initialization Register 2 Bit[7] — R/W. BIOS sets this bit to 1.
6:0	Reserved

7.1.60 CSIR3—Chipset Initialization Register 3

Offset Address: 3E0Eh Attribute: R/W
 Default Value: 00h Size: 8-bits

Bit	Description
7	Chipset Initialization Register 3 Bit[7] — R/W. BIOS sets this bit to 1.
6:0	Reserved

7.1.61 CSIR4—Chipset Initialization Register 4

Offset Address: 3E4Eh Attribute: R/W
 Default Value: 00h Size: 8-bits

Bit	Description
7	Chipset Initialization Register 4 Bit[7] — R/W. BIOS sets this bit to 1.
6:0	Reserved

§



8 LAN Controller Registers (B1:D8:F0)

The ICH6 integrated LAN controller appears to reside at PCI Device 8, Function 0 on the secondary side of the ICH6’s virtual PCI-to-PCI bridge. This is typically Bus 1, but may be assigned a different number depending upon system configuration. The LAN controller acts as both a master and a slave on the PCI bus. As a master, the LAN controller interacts with the system main memory to access data for transmission or deposit received data. As a slave, some of the LAN controller’s control structures are accessed by the host processor to read or write information to the on-chip registers. The processor also provides the LAN controller with the necessary commands and pointers that allow it to process receive and transmit data.

8.1 PCI Configuration Registers (LAN Controller—B1:D8:F0)

Note: Address locations that are not shown should be treated as Reserved (See Section 6.2 for details).

Table 8-1. LAN Controller PCI Register Address Map (LAN Controller—B1:D8:F0) (Sheet 1 of 2)

Offset	Mnemonic	Register Name	Default	Type
00–01h	VID	Vendor Identification	8086h	RO
02–03h	DID	Device Identification	1065h	RO
04–05h	PCICMD	PCI Command	0000h	RO, R/W
06–07h	PCISTS	PCI Status	0290h	RO, R/WC
08h	RID	Revision Identification	See register description.	RO
0Ah	SCC	Sub Class Code	00h	RO
0Bh	BCC	Base Class Code	02	RO
0Ch	CLS	Cache Line Size	00h	R/W
0Dh	PMLT	Primary Master Latency Timer	00h	R/W
0Eh	HEADTYP	Header Type	00h	RO
10–13h	CSR_MEM_BASE	CSR Memory–Mapped Base Address	00000008h	R/W, RO
14–17h	CSR_IO_BASE	CSR I/O–Mapped Base Address	00000001h	R/W, RO
2C–2Dh	SVID	Subsystem Vendor Identification	0000h	RO
2E–2Fh	SID	Subsystem Identification	0000h	RO
34h	CAP_PTR	Capabilities Pointer	DCh	RO
3Ch	INT_LN	Interrupt Line	00h	R/W
3Dh	INT_PN	Interrupt Pin	01h	RO
3Eh	MIN_GNT	Minimum Grant	08h	RO
3Fh	MAX_LAT	Maximum Latency	38h	RO
DCh	CAP_ID	Capability ID	01h	RO
DDh	NXT_PTR	Next Item Pointer	00h	RO

Table 8-1. LAN Controller PCI Register Address Map (LAN Controller—B1:D8:F0) (Sheet 2 of 2)

Offset	Mnemonic	Register Name	Default	Type
DE–DFh	PM_CAP	Power Management Capabilities	FE21h (Desktop) 7E21h (Mobile)	RO
E0–E1h	PMCSR	Power Management Control/Status	0000h	R/W, RO, R/WC
E3	PCIDATA	PCI Power Management Data	00h	RO

8.1.1 VID—Vendor Identification Register (LAN Controller—B1:D8:F0)

Offset Address: 00–01h Attribute: RO
 Default Value: 8086h Size: 16 bits

Bit	Description
15:0	Vendor ID — RO. This is a 16-bit value assigned to Intel.

8.1.2 DID—Device Identification Register (LAN Controller—B1:D8:F0)

Offset Address: 02–03h Attribute: RO
 Default Value: 1065h Size: 16 bits

Bit	Description
15:0	<p>Device ID — RO. This is a 16-bit value assigned to the ICH6 integrated LAN controller.</p> <ol style="list-style-type: none"> If the EEPROM is not present (or not properly programmed), reads to the Device ID return the default value of 1065h. If the EEPROM is present (and properly programmed) and if the value of word 23h is not 0000h or FFFFh, the Device ID is loaded from the EEPROM, word 23h after the hardware reset. (See Section 8.1.14 - SID, Subsystem ID of LAN controller for detail)

8.1.3 PCICMD—PCI Command Register (LAN Controller—B1:D8:F0)

Offset Address: 04–05h
 Default Value: 0000h

Attribute: RO, R/W
 Size: 16 bits

Bit	Description
15:11	Reserved
10	Interrupt Disable — R/W. 0 = Enable. 1 = Disables LAN controller to assert its INTA signal.
9	Fast Back to Back Enable (FBE) — RO. Hardwired to 0. The integrated LAN controller will not run fast back-to-back PCI cycles.
8	SERR# Enable (SERR_EN) — R/W. 0 = Disable. 1 = Enable. Allow SERR# to be asserted.
7	Wait Cycle Control (WCC) — RO. Hardwired to 0. Not implemented.
6	Parity Error Response (PER) — R/W. 0 = The LAN controller will ignore PCI parity errors. 1 = The integrated LAN controller will take normal action when a PCI parity error is detected and will enable generation of parity on DMI.
5	VGA Palette Snoop (VPS) — RO. Hardwired to 0. Not Implemented.
4	Memory Write and Invalidate Enable (MWIE) — R/W. 0 = Disable. The LAN controller will not use the Memory Write and Invalidate command. 1 = Enable.
3	Special Cycle Enable (SCE) — RO. Hardwired to 0. The LAN controller ignores special cycles.
2	Bus Master Enable (BME) — R/W. 0 = Disable. 1 = Enable. The ICH6's integrated LAN controller may function as a PCI bus master.
1	Memory Space Enable (MSE) — R/W. 0 = Disable. 1 = Enable. The ICH6's integrated LAN controller will respond to the memory space accesses.
0	I/O Space Enable (IOSE) — R/W. 0 = Disable. 1 = Enable. The ICH6's integrated LAN controller will respond to the I/O space accesses.

8.1.4 PCISTS—PCI Status Register (LAN Controller—B1:D8:F0)

Offset Address: 06–07h
Default Value: 0290h

Attribute: RO, R/WC
Size: 16 bits

Note: For the writable bits, software must write a 1 to clear bits that are set. Writing a 0 to the bit has no effect.

Bit	Description
15	Detected Parity Error (DPE) — R/WC. 0 = Parity error Not detected. 1 = The Intel® ICH6's integrated LAN controller has detected a parity error on the PCI bus (will be set even if Parity Error Response is disabled in the PCI Command register).
14	Signaled System Error (SSE) — R/WC. 0 = Integrated LAN controller has not asserted SERR# 1 = The ICH6's integrated LAN controller has asserted SERR#. SERR# can be routed to cause NMI, SMI#, or interrupt.
13	Master Abort Status (RMA) — R/WC. 0 = Master Abort not generated 1 = The ICH6's integrated LAN controller (as a PCI master) has generated a master abort.
12	Received Target Abort (RTA) — R/WC. 0 = Target abort not received. 1 = The ICH6's integrated LAN controller (as a PCI master) has received a target abort.
11	Signaled Target Abort (STA) — RO. Hardwired to 0. The device will never signal Target Abort.
10:9	DEVSEL# Timing Status (DEV_STS) — RO. 01h = Medium timing.
8	Data Parity Error Detected (DPED) — R/WC. 0 = Parity error not detected (conditions below are not met). 1 = All of the following three conditions have been met: 1.The LAN controller is acting as bus master 2.The LAN controller has asserted PERR# (for reads) or detected PERR# asserted (for writes) 3.The Parity Error Response bit in the LAN controller's PCI Command Register is set.
7	Fast Back to Back Capable (FB2BC) — RO. Hardwired to 1. The device can accept fast back-to-back transactions.
6	User Definable Features (UDF) — RO. Hardwired to 0. Not implemented.
5	66 MHz Capable (66MHZ_CAP) — RO. Hardwired to 0. The device does not support 66 MHz PCI.
4	Capabilities List (CAP_LIST) — RO. 0 = The EEPROM indicates that the integrated LAN controller does not support PCI Power Management. 1 = The EEPROM indicates that the integrated LAN controller supports PCI Power Management.
3	Interrupt Status (INTS) — RO. This bit indicates that an interrupt is pending. It is independent from the state of the Interrupt Enable bit in the command register.
2:0	Reserved

**8.1.5 RID—Revision Identification Register
(LAN Controller—B1:D8:F0)**

Offset Address: 08h Attribute: RO
 Default Value: See bit description Size: 8 bits

Bit	Description
7:0	Revision ID (RID) — RO. This field is an 8-bit value that indicates the revision number for the integrated LAN controller. The three least significant bits in this register may be overridden by the ID and REV ID fields in the EEPROM. Refer to the <i>Intel® I/O Controller Hub 6 (ICH6) Family Specification Update</i> for the value of the Revision ID Register.

**8.1.6 SCC—Sub Class Code Register
(LAN Controller—B1:D8:F0)**

Offset Address: 0Ah Attribute: RO
 Default Value: 00h Size: 8 bits

Bit	Description
7:0	Sub Class Code (SCC) — RO. This 8-bit value specifies the sub-class of the device as an Ethernet controller.

**8.1.7 BCC—Base-Class Code Register
(LAN Controller—B1:D8:F0)**

Offset Address: 0Bh Attribute: RO
 Default Value: 02h Size: 8 bits

Bit	Description
7:0	Base Class Code (BCC) — RO. This 8-bit value specifies the base class of the device as a network controller.

8.1.8 CLS—Cache Line Size Register (LAN Controller—B1:D8:F0)

Offset Address: 0Ch Attribute: R/W
 Default Value: 00h Size: 8 bits

Bit	Description
7:5	Reserved
4:3	<p>Cache Line Size (CLS) — R/W.</p> <p>00 = Memory Write and Invalidate (MWI) command will not be used by the integrated LAN controller.</p> <p>01 = MWI command will be used with Cache Line Size set to 8 DWords (only set if a value of 08h is written to this register).</p> <p>10 = MWI command will be used with Cache Line Size set to 16 DWords (only set if a value of 10h is written to this register).</p> <p>11 = Invalid. MWI command will not be used.</p>
2:0	Reserved

8.1.9 PMLT—Primary Master Latency Timer Register (LAN Controller—B1:D8:F0)

Offset Address: 0Dh Attribute: R/W
 Default Value: 00h Size: 8 bits

Bit	Description
7:3	<p>Master Latency Timer Count (MLTC) — R/W. This field defines the number of PCI clock cycles that the integrated LAN controller may own the bus while acting as bus master.</p>
2:0	Reserved

8.1.10 HEADTYP—Header Type Register (LAN Controller—B1:D8:F0)

Offset Address: 0Eh Attribute: RO
 Default Value: 00h Size: 8 bits

Bit	Description
7	Multi-Function Device (MFD) — RO. Hardwired to 0 to indicate a single function device.
6:0	Header Type (HTYPE) — RO. This 7-bit field identifies the header layout of the configuration space as an Ethernet controller.

8.1.11 CSR_MEM_BASE — CSR Memory-Mapped Base Address Register (LAN Controller—B1:D8:F0)

Offset Address: 10–13h Attribute: R/W, RO
 Default Value: 00000008h Size: 32 bits

Note: The ICH6’s integrated LAN controller requires one BAR for memory mapping. Software determines which BAR (memory or I/O) is used to access the LAN controller’s CSR registers.

Bit	Description
31:12	Base Address (MEM_ADDR) — R/W. This field contains the upper 20 bits of the base address provides 4 KB of memory-Mapped space for the LAN controller’s Control/Status registers.
11:4	Reserved
3	Prefetchable (MEM_PF) — RO. Hardwired to 0 to indicate that this is not a pre-fetchable memory-Mapped address range.
2:1	Type (MEM_TYPE) — RO. Hardwired to 00b to indicate the memory-Mapped address range may be located anywhere in 32-bit address space.
0	Memory-Space Indicator (MEM_SPACE) — RO. Hardwired to 0 to indicate that this base address maps to memory space.

8.1.12 CSR_IO_BASE — CSR I/O-Mapped Base Address Register (LAN Controller—B1:D8:F0)

Offset Address: 14–17h Attribute: R/W, RO
 Default Value: 00000001h Size: 32 bits

Note: The ICH6’s integrated LAN controller requires one BAR for memory mapping. Software determines which BAR (memory or I/O) is used to access the LAN controller’s CSR registers.

Bit	Description
31:16	Reserved
15:6	Base Address (IO_ADDR) — R/W. This field provides 64 bytes of I/O-Mapped address space for the LAN controller’s Control/Status registers.
5:1	Reserved
0	I/O Space Indicator (IO_SPACE) — RO. Hardwired to 1 to indicate that this base address maps to I/O space.

8.1.13 SVID — Subsystem Vendor Identification (LAN Controller—B1:D8:F0)

Offset Address: 2C–2D Attribute: RO
 Default Value: 0000h Size: 16 bits

Bit	Description
15:0	Subsystem Vendor ID (SVID) — RO. See Section 8.1.14 for details.

8.1.14 SID — Subsystem Identification (LAN Controller—B1:D8:F0)

Offset Address: 2E–2Fh Attribute: RO
 Default Value: 0000h Size: 16 bits

Bit	Description
15:0	Subsystem ID (SID) — RO.

Note: The ICH6's integrated LAN controller provides support for configurable Subsystem ID and Subsystem Vendor ID fields. After reset, the LAN controller automatically reads addresses Ah through Ch, and 23h of the EEPROM. The LAN controller checks bits 15:13 in the EEPROM word Ah, and functions according to [Table 8-2](#).

Table 8-2. Configuration of Subsystem ID and Subsystem Vendor ID via EEPROM

Bits 15:14	Bit 13	Device ID	Vendor ID	Revision ID	Subsystem ID	Subsystem Vendor ID
11b, 10b, 00b	X	1051h	8086h	00h	0000h	0000h
01b	0b	Word 23h	8086h	00h	Word Bh	Word Ch
01b	1b	Word 23h	Word Ch	80h + Word Ah, bits 10:8	Word Bh	Word Ch

NOTES:

1. The Revision ID is subject to change according to the silicon stepping.
2. The Device ID is loaded from Word 23h only if the value of Word 23h is not 0000h or FFFFh

8.1.15 CAP_PTR — Capabilities Pointer (LAN Controller—B1:D8:F0)

Offset Address: 34h Attribute: RO
 Default Value: DCh Size: 8 bits

Bit	Description
7:0	Capabilities Pointer (CAP_PTR) — RO. Hardwired to DCh to indicate the offset within configuration space for the location of the Power Management registers.

8.1.16 INT_LN — Interrupt Line Register (LAN Controller—B1:D8:F0)

Offset Address: 3Ch Attribute: R/W
 Default Value: 00h Size: 8 bits

Bit	Description
7:0	Interrupt Line (INT_LN) — R/W. This field identifies the system interrupt line to which the LAN controller's PCI interrupt request pin (as defined in the Interrupt Pin Register) is routed.

8.1.17 INT_PN — Interrupt Pin Register (LAN Controller—B1:D8:F0)

Offset Address: 3Dh Attribute: RO
 Default Value: 01h Size: 8 bits

Bit	Description
7:0	Interrupt Pin (INT_PN) — RO. Hardwired to 01h to indicate that the LAN controller's interrupt request is connected to PIRQA#. However, in the ICH6 implementation, when the LAN controller interrupt is generated PIRQE# will go active, not PIRQA#. Note that if the PIRQE# signal is used as a GPI, the external visibility will be lost (though PIRQE# will still go active internally).

8.1.18 MIN_GNT — Minimum Grant Register (LAN Controller—B1:D8:F0)

Offset Address: 3Eh Attribute: RO
 Default Value: 08h Size: 8 bits

Bit	Description
7:0	Minimum Grant (MIN_GNT) — RO. This field indicates the amount of time (in increments of 0.25 μs) that the LAN controller needs to retain ownership of the PCI bus when it initiates a transaction.

8.1.19 MAX_LAT — Maximum Latency Register (LAN Controller—B1:D8:F0)

Offset Address: 3Fh Attribute: RO
 Default Value: 38h Size: 8 bits

Bit	Description
7:0	Maximum Latency (MAX_LAT) — RO. This field defines how often (in increments of 0.25 μs) the LAN controller needs to access the PCI bus.

8.1.20 CAP_ID — Capability Identification Register (LAN Controller—B1:D8:F0)

Offset Address: DCh Attribute: RO
 Default Value: 01h Size: 8 bits

Bit	Description
7:0	Capability ID (CAP_ID) — RO. Hardwired to 01h to indicate that the Intel® ICH6's integrated LAN controller supports PCI power management.

8.1.21 NXT_PTR — Next Item Pointer (LAN Controller—B1:D8:F0)

Offset Address: DDh Attribute: RO
 Default Value: 00h Size: 8 bits

Bit	Description
7:0	Next Item Pointer (NXT_PTR) — RO. Hardwired to 00b to indicate that power management is the last item in the capabilities list.

8.1.22 PM_CAP — Power Management Capabilities (LAN Controller—B1:D8:F0)

Offset Address: DE–DFh Attribute: RO
 Default Value: FE21h (In Desktop) Size: 16 bits
 7E21h (In Mobile)

Bit	Description
15:11	PME Support (PME_SUP) — RO. Hardwired to 11111b. This 5-bit field indicates the power states in which the LAN controller may assert PME#. The LAN controller supports wake-up in all power states.
10	D2 Support (D2_SUP) — RO. Hardwired to 1 to indicate that the LAN controller supports the D2 power state.
9	D1 Support (D1_SUP) — RO. Hardwired to 1 to indicate that the LAN controller supports the D1 power state.
8:6	Auxiliary Current (AUX_CUR) — RO. Hardwired to 000b to indicate that the LAN controller implements the Data registers. The auxiliary power consumption is the same as the current consumption reported in the D3 state in the Data register.
5	Device Specific Initialization (DSI) — RO. Hardwired to 1 to indicate that special initialization of this function is required (beyond the standard PCI configuration header) before the generic class device driver is able to use it. DSI is required for the LAN controller after D3-to-D0 reset.
4	Reserved
3	PME Clock (PME_CLK) — RO. Hardwired to 0 to indicate that the LAN controller does not require a clock to generate a power management event.
2:0	Version (VER) — RO. Hardwired to 010b to indicate that the LAN controller complies with of the <i>PCI Power Management Specification, Revision 1.1</i> .

8.1.23 PMCSR — Power Management Control/ Status Register (LAN Controller—B1:D8:F0)

Offset Address: E0–E1h Attribute: RO, R/W, R/WC
 Default Value: 0000h Size: 16 bits

Bit	Description
15	PME Status (PME_STAT) — R/WC. 0 = Software clears this bit by writing a 1 to it. This also de-asserts the PME# signal and clears the PME status bit in the Power Management Driver Register. When the PME# signal is enabled, the PME# signal reflects the state of the PME status bit. 1 = Set upon occurrence of a wake-up event, independent of the state of the PME enable bit.
14:13	Data Scale (DSCALE) — RO. This field indicates the data register scaling factor. It equals 10b for registers 0 through 8 and 00b for registers nine through fifteen, as selected by the "Data Select" field.
12:9	Data Select (DSEL) — R/W. This field is used to select which data is reported through the Data register and Data Scale field.
8	PME Enable (PME_EN) — R/W. This bit enables the ICH6's integrated LAN controller to assert PME#. 0 = The device will not assert PME#. 1 = Enable PME# assertion when PME Status is set.
7:5	Reserved
4	Dynamic Data (DYN_DAT) — RO. Hardwired to 0 to indicate that the device does not support the ability to monitor the power consumption dynamically.
3:2	Reserved
1:0	Power State (PWR_ST) — R/W. This 2-bit field is used to determine the current power state of the integrated LAN controller, and to put it into a new power state. The definition of the field values is as follows: 00 = D0 01 = D1 10 = D2 11 = D3

8.1.24 PCIDATA — PCI Power Management Data Register (LAN Controller—B1:D8:F0)

Offset Address: E3h
Default Value: 00h

Attribute: RO
Size: 8 bits

Bit	Description
7:0	Power Management Data (PWR_MGT) — RO. State dependent power consumption and heat dissipation data.

The data register is an 8-bit read only register that provides a mechanism for the ICH6’s integrated LAN controller to report state dependent maximum power consumption and heat dissipation. The value reported in this register depends on the value written to the Data Select field in the PMCSR register. The power measurements defined in this register have a dynamic range of 0 W to 2.55 W with 0.01 W resolution, scaled according to the Data Scale field in the PMCSR. The structure of the Data Register is given in Table 8-3.

Table 8-3. Data Register Structure

Data Select	Data Scale	Data Reported
0	2	D0 Power Consumption
1	2	D1 Power Consumption
2	2	D2 Power Consumption
3	2	D3 Power Consumption
4	2	D0 Power Dissipated
5	2	D1 Power Dissipated
6	2	D2 Power Dissipated
7	2	D3 Power Dissipated
8	2	Common Function Power Dissipated
9–15	0	Reserved

8.2 LAN Control / Status Registers (CSR) (LAN Controller—B1:D8:F0)

Table 8-4. Intel® ICH6 Integrated LAN Controller CSR Space Register Address Map

Offset	Mnemonic	Register Name	Default	Type
00h–01h	SCB_STA	System Control Block Status Word	0000h	R/WC, RO
02h–03h	SCB_CMD	System Control Block Command Word	0000h	R/W, WO
04h–07h	SCB_GENPNT	System Control Block General Pointer	0000 0000h	R/W
08h–0Bh	PORT	PORT Interface	0000 0000h	R/W (special)
0Ch–0Dh	—	Reserved	—	—
0Eh	EEPROM_CNTL	EEPROM Control	00	R/W, RO, WO
0Fh	—	Reserved	—	—
10h–13h	MDI_CNTL	Management Data Interface Control	0000 0000h	R/W (special)
14h–17h	REC_DMA_BC	Receive DMA Byte Count	0000 0000h	RO
18h	EREC_INTR	Early Receive Interrupt	00h	R/W
19–1Ah	FLOW_CNTL	Flow Control	0000h	RO, R/W (special)
1Bh	PMDR	Power Management Driver	00h	R/WC
1Ch	GENCNTL	General Control	00h	R/W
1Dh	GENSTA	General Status	00h	RO
1Eh	—	Reserved	—	—
1Fh	SMB_PCI	SMB via PCI	27h	R/W, RO
20h–3Ch	—	Reserved	—	—

8.2.1 SCB_STA—System Control Block Status Word Register (LAN Controller—B1:D8:F0)

Offset Address: 00–01h Attribute: R/WC, RO
 Default Value: 0000h Size: 16 bits

The ICH6's integrated LAN controller places the status of its Command Unit (CU) and Receive Unit (RC) and interrupt indications in this register for the processor to read.

Bit	Description
15	Command Unit (CU) Executed (CX) — R/WC. 0 = Software acknowledges the interrupt and clears this bit by writing a 1 to the bit position. 1 = Interrupt signaled because the CU has completed executing a command with its interrupt bit set.
14	Frame Received (FR) — R/WC. 0 = Software acknowledges the interrupt and clears this bit by writing a 1 to the bit position. 1 = Interrupt signaled because the Receive Unit (RU) has finished receiving a frame.
13	CU Not Active (CNA) — R/WC. 0 = Software acknowledges the interrupt and clears this bit by writing a 1 to the bit position. 1 = The Command Unit left the Active state or entered the Idle state. There are 2 distinct states of the CU. When configured to generate CNA interrupt, the interrupt will be activated when the CU leaves the Active state and enters either the Idle or the Suspended state. When configured to generate CI interrupt, an interrupt will be generated only when the CU enters the Idle state.
12	Receive Not Ready (RNR) — R/WC. 0 = Software acknowledges the interrupt and clears this bit by writing a 1 to the bit position. 1 = Interrupt signaled because the Receive Unit left the Ready state. This may be caused by an RU Abort command, a no resources situation, or set suspend bit due to a filled Receive Frame Descriptor.
11	Management Data Interrupt (MDI) — R/WC. 0 = Software acknowledges the interrupt and clears this bit by writing a 1 to the bit position. 1 = Set when a Management Data Interface read or write cycle has completed. The management data interrupt is enabled through the interrupt enable bit (bit 29 in the Management Data Interface Control register in the CSR).
10	Software Interrupt (SWI) — R/WC. 0 = Software acknowledges the interrupt and clears this bit by writing a 1 to the bit position. 1 = Set when software generates an interrupt.
9	Early Receive (ER) — R/WC. 0 = Software acknowledges the interrupt and clears this bit by writing a 1 to the bit position. 1 = Indicates the occurrence of an Early Receive Interrupt.
8	Flow Control Pause (FCP) — R/WC. 0 = Software acknowledges the interrupt and clears this bit by writing a 1 to the bit position. 1 = Indicates Flow Control Pause interrupt.
7:6	Command Unit Status (CUS) — RO. 00 = Idle 01 = Suspended 10 = LPQ (Low Priority Queue) active 11 = HPQ (High Priority Queue) active



Bit	Description			
5:2	Receive Unit Status (RUS) — RO.			
	Value	Status	Value	Status
	0000b	Idle	1000b	Reserved
	0001b	Suspended	1001b	Suspended with no more RBDs
	0010b	No Resources	1010b	No resources due to no more RBDs
	0011b	Reserved	1011b	Reserved
	0100b	Ready	1100b	Ready with no RBDs present
	0101b	Reserved	1101b	Reserved
	0110b	Reserved	1110b	Reserved
	0111b	Reserved	1111b	Reserved
1:0	Reserved			

8.2.2 SCB_CMD—System Control Block Command Word Register (LAN Controller—B1:D8:F0)

Offset Address: 02–03h Attribute: R/W, WO
 Default Value: 0000h Size: 16 bits

The processor places commands for the Command and Receive units in this register. Interrupts are also acknowledged in this register.

Bit	Description
15	CX Mask (CX_MSK) — R/W. 0 = Interrupt not masked. 1 = Disable the generation of a CX interrupt.
14	FR Mask (FR_MSK) — R/W. 0 = Interrupt not masked. 1 = Disable the generation of an FR interrupt.
13	CNA Mask (CNA_MSK) — R/W. 0 = Interrupt not masked. 1 = Disable the generation of a CNA interrupt.
12	RNR Mask (RNR_MSK) — R/W. 0 = Interrupt not masked. 1 = Disable the generation of an RNR interrupt.
11	ER Mask (ER_MSK) — R/W. 0 = Interrupt not masked. 1 = Disable the generation of an ER interrupt.
10	FCP Mask (FCP_MSK) — R/W. 0 = Interrupt not masked. 1 = Disable the generation of an FCP interrupt.
9	Software Generated Interrupt (SI) — WO. 0 = No Effect. 1 = Setting this bit causes the LAN controller to generate an interrupt.
8	Interrupt Mask (IM) — R/W. This bit enables or disables the LAN controller's assertion of the INTA# signal. This bit has higher precedence than the Specific Interrupt Mask bits and the SI bit. 0 = Enable the assertion of INTA#. 1 = Disable the assertion of INTA#.

Bit	Description
7:4	<p>Command Unit Command (CUC) — R/W. Valid values are listed below. All other values are Reserved.</p> <p>0000 = NOP: Does not affect the current state of the unit.</p> <p>0001 = CU Start: Start execution of the first command on the CBL. A pointer to the first CB of the CBL should be placed in the SCB General Pointer before issuing this command. The CU Start command should only be issued when the CU is in the Idle or Suspended states (never when the CU is in the active state), and all of the previously issued Command Blocks have been processed and completed by the CU. Sometimes it is only possible to determine that all Command Blocks are completed by checking that the Complete bit is set in all previously issued Command Blocks.</p> <p>0010 = CU Resume: Resume operation of the Command unit by executing the next command. This command will be ignored if the CU is idle.</p> <p>0011 = CU HPQ Start: Start execution of the first command on the high priority CBL. A pointer to the first CB of the HPQ CBL should be placed in the SCB General Pointer before issuing this command.</p> <p>0100 = Load Dump Counters Address: Indicates to the device where to write dump data when using the Dump Statistical Counters or Dump and Reset Statistical Counters commands. This command must be executed at least once before any usage of the Dump Statistical Counters or Dump and Reset Statistical Counters commands. The address of the dump area must be placed in the General Pointer register.</p> <p>0101 = Dump Statistical Counters: Tells the device to dump its statistical counters to the area designated by the Load Dump Counters Address command.</p> <p>0110 = Load CU Base: The device's internal CU Base Register is loaded with the value in the CSB General Pointer.</p> <p>0111 = Dump and Reset Statistical Counters: Indicates to the device to dump its statistical counters to the area designated by the Load Dump Counters Address command, and then to clear these counters.</p> <p>1010 = CU Static Resume: Resume operation of the Command unit by executing the next command. This command will be ignored if the CU is idle. This command should be used only when the CU is in the Suspended state and has no pending CU Resume commands.</p> <p>1011 = CU HPQ Resume: Resume execution of the first command on the HPQ CBL. this command will be ignored if the HPQ was never started.</p>
3	Reserved
2:0	<p>Receive Unit Command (RUC) — R/W. Valid values are:</p> <p>000 = NOP: Does not affect the current state of the unit.</p> <p>001 = RU Start: Enables the receive unit. The pointer to the RFA must be placed in the SCB General Pointer before using this command. The device pre-fetches the first RFD and the first RBD (if in flexible mode) in preparation to receive incoming frames that pass its address filtering.</p> <p>010 = RU Resume: Resume frame reception (only when in suspended state).</p> <p>011 = RCV DMA Redirect: Resume the RCV DMA when configured to "Direct DMA Mode." The buffers are indicated by an RBD chain which is pointed to by an offset stored in the General Pointer Register (this offset will be added to the RU Base).</p> <p>100 = RU Abort: Abort RU receive operation immediately.</p> <p>101 = Load Header Data Size (HDS): This value defines the size of the Header portion of the RFDs or Receive buffers. The HDS value is defined by the lower 14 bits of the SCB General Pointer, so bits 31:15 should always be set to 0's when using this command. Once a Load HDS command is issued, the device expects only to find Header RFDs, or be used in "RCV Direct DMA mode" until it is reset. Note that the value of HDS should be an even, non-zero number.</p> <p>110 = Load RU Base: The device's internal RU Base Register is loaded with the value in the SCB General Pointer.</p> <p>111 = RBD Resume: Resume frame reception into the RFA. This command should only be used when the RU is already in the "No Resources due to no RBDs" state or the "Suspended with no more RBDs" state.</p>

8.2.3 SCB_GENPNT—System Control Block General Pointer Register (LAN Controller—B1:D8:F0)

Offset Address: 04–07h Attribute: R/W
 Default Value: 0000 0000h Size: 32 bits

Bit	Description
15:0	SCB General Pointer — R/W. The SCB General Pointer register is programmed by software to point to various data structures in main memory depending on the current SCB Command word.

8.2.4 PORT—PORT Interface Register (LAN Controller—B1:D8:F0)

Offset Address: 08–0Bh Attribute: R/W (special)
 Default Value: 0000 0000h Size: 32 bits

The PORT interface allows the processor to reset the ICH6's internal LAN controller, or perform an internal self test. The PORT DWord may be written as a 32-bit entity, two 16-bit entities, or four 8-bit entities. The LAN controller will only accept the command after the high byte (offset 0Bh) is written; therefore, the high byte must be written last.

Bit	Description
31:4	Pointer Field (PORT_PTR) — R/W (special). A 16-byte aligned address must be written to this field when issuing a Self-Test command to the PORT interface. The results of the Self Test will be written to the address specified by this field.
3:0	<p>PORT Function Selection (PORT_FUNC) — R/W (special). Valid values are listed below. All other values are reserved.</p> <p>0000 = PORT Software Reset: Completely resets the LAN controller (all CSR and PCI registers). This command should not be used when the device is active. If a PORT Software Reset is desired, software should do a Selective Reset (described below), wait for the PORT register to be cleared (completion of the Selective Reset), and then issue the PORT Software Reset command. Software should wait approximately 10 μs after issuing this command before attempting to access the LAN controller's registers again.</p> <p>0001 = Self Test: The Self-Test begins by issuing an internal Selective Reset followed by a general internal self-test of the LAN controller. The results of the self-test are written to memory at the address specified in the Pointer field of this register. The format of the self-test result is shown in Table 8-5. After completing the self-test and writing the results to memory, the LAN controller will execute a full internal reset and will re-initialize to the default configuration. Self-Test does not generate an interrupt of similar indicator to the host processor upon completion.</p> <p>0010 = Selective Reset: Sets the CU and RU to the Idle state, but otherwise maintains the current configuration parameters (RU and CU Base, HDSSize, Error Counters, Configure information and Individual/Multicast Addresses are preserved). Software should wait approximately 10 μs after issuing this command before attempting to access the LAN controller's registers again.</p>

8.2.6 MDI_CNTL—Management Data Interface (MDI) Control Register (LAN Controller—B1:D8:F0)

Offset Address: 10–13h Attribute: R/W (special)
 Default Value: 0000 0000h Size: 32 bits

The Management Data Interface (MDI) Control register is a 32-bit field and is used to read and write bits from the LAN Connect component. This register may be written as a 32-bit entity, two 16-bit entities, or four 8-bit entities. The LAN controller will only accept the command after the high byte (offset 13h) is written; therefore, the high byte must be written last.

Bit	Description
31:30	These bits are reserved and should be set to 00b.
29	Interrupt Enable — R/W (special). 0 = Disable. 1 = Enables the LAN controller to assert an interrupt to indicate the end of an MDI cycle.
28	Ready — R/W (special). 0 = Expected to be reset by software at the same time the command is written. 1 = Set by the LAN controller at the end of an MDI transaction.
27:26	Opcode — R/W (special). These bits define the opcode: 00 = Reserved 01 = MDI write 10 = MDI read 11 = Reserved
25:21	LAN Connect Address — R/W (special). This field of bits contains the LAN Connect address.
20:16	LAN Connect Register Address — R/W (special). This field contains the LAN Connect Register Address.
15:0	Data — R/W (special). In a write command, software places the data bits in this field, and the LAN controller transfers the data to the external LAN Connect component. During a read command, the LAN controller reads these bits serially from the LAN Connect, and software reads the data from this location.

8.2.7 REC_DMA_BC—Receive DMA Byte Count Register (LAN Controller—B1:D8:F0)

Offset Address: 14–17h Attribute: RO
 Default Value: 0000 0000h Size: 32 bits

Bit	Description
31:0	Receive DMA Byte Count — RO. This field keeps track of how many bytes of receive data have been passed into host memory via DMA.

8.2.8 EREC_INTR—Early Receive Interrupt Register (LAN Controller—B1:D8:F0)

Offset Address:	18h	Attribute:	R/W
Default Value:	00h	Size:	8 bits

The Early Receive Interrupt register allows the internal LAN controller to generate an early interrupt depending on the length of the frame. The LAN controller will generate an interrupt at the end of the frame regardless of whether or not Early Receive Interrupts are enabled.

Note: It is recommended that software **not** use this register unless receive interrupt latency is a critical performance issue in that particular software environment. Using this feature may reduce receive interrupt latency, but will also result in the generation of more interrupts, which can degrade system efficiency and performance in some environments.

Bit	Description
7:0	Early Receive Count — R/W. When some non-zero value x is programmed into this register, the LAN controller will set the ER bit in the SCB Status Word Register and assert INTA# when the byte count indicates that there are x QWords remaining to be received in the current frame (based on the Type/Length field of the received frame). No Early Receive interrupt will be generated if a value of 00h (the default value) is programmed into this register.

8.2.9 FLOW_CNTL—Flow Control Register (LAN Controller—B1:D8:F0)

Offset Address: 19–1Ah
Default Value: 0000h

Attribute: RO, R/W (special)
Size: 16 bits

Bit	Description																											
15:13	Reserved																											
12	<p>FC Paused Low — RO.</p> <p>0 = Cleared when the FC timer reaches 0, or a Pause frame is received. 1 = Set when the LAN controller receives a Pause Low command with a value greater than 0.</p>																											
11	<p>FC Paused — RO.</p> <p>0 = Cleared when the FC timer reaches 0. 1 = Set when the LAN controller receives a Pause command regardless of its cause (FIFO reaching Flow Control Threshold, fetching a Receive Frame Descriptor with its Flow Control Pause bit set, or software writing a 1 to the Xoff bit).</p>																											
10	<p>FC Full — RO.</p> <p>0 = Cleared when the FC timer reaches 0. 1 = Set when the LAN controller sends a Pause command with a value greater than 0.</p>																											
9	<p>Xoff — R/W (special). This bit should only be used if the LAN controller is configured to operate with IEEE frame-based flow control.</p> <p>0 = This bit can only be cleared by writing a 1 to the Xon bit (bit 8 in this register). 1 = Writing a 1 to this bit forces the Xoff request to 1 and causes the LAN controller to behave as if the FIFO extender is full. This bit will also be set to 1 when an Xoff request due to an “RFD Xoff” bit.</p>																											
8	<p>Xon — WO. This bit should only be used if the LAN controller is configured to operate with IEEE frame-based flow control.</p> <p>0 = This bit always returns 0 on reads. 1 = Writing a 1 to this bit resets the Xoff request to the LAN controller, clearing bit 9 in this register.</p>																											
7:3	Reserved																											
2:0	<p>Flow Control Threshold — R/W. The LAN controller can generate a Flow Control Pause frame when its Receive FIFO is almost full. The value programmed into this field determines the number of bytes still available in the Receive FIFO when the Pause frame is generated.</p> <table border="1"> <thead> <tr> <th>Bits 2:0</th> <th>Free Bytes in RX FIFO</th> <th>Comment</th> </tr> </thead> <tbody> <tr> <td>000b</td> <td>0.50 KB</td> <td>Fast system (recommended default)</td> </tr> <tr> <td>001b</td> <td>1.00 KB</td> <td></td> </tr> <tr> <td>010b</td> <td>1.25 KB</td> <td></td> </tr> <tr> <td>011b</td> <td>1.50 KB</td> <td></td> </tr> <tr> <td>100b</td> <td>1.75 KB</td> <td></td> </tr> <tr> <td>101b</td> <td>2.00 KB</td> <td></td> </tr> <tr> <td>110b</td> <td>2.25 KB</td> <td></td> </tr> <tr> <td>111b</td> <td>2.50 KB</td> <td>Slow system</td> </tr> </tbody> </table>	Bits 2:0	Free Bytes in RX FIFO	Comment	000b	0.50 KB	Fast system (recommended default)	001b	1.00 KB		010b	1.25 KB		011b	1.50 KB		100b	1.75 KB		101b	2.00 KB		110b	2.25 KB		111b	2.50 KB	Slow system
Bits 2:0	Free Bytes in RX FIFO	Comment																										
000b	0.50 KB	Fast system (recommended default)																										
001b	1.00 KB																											
010b	1.25 KB																											
011b	1.50 KB																											
100b	1.75 KB																											
101b	2.00 KB																											
110b	2.25 KB																											
111b	2.50 KB	Slow system																										

8.2.10 PMDR—Power Management Driver Register (LAN Controller—B1:D8:F0)

Offset Address: 1Bh Attribute: R/WC
 Default Value: 00h Size: 8 bits

The ICH6's internal LAN controller provides an indication in the PMDR that a wake-up event has occurred.

Bit	Description
7	Link Status Change Indication — R/WC. 0 = Software clears this bit by writing a 1 to it. 1 = The link status change bit is set following a change in link status.
6	Magic Packet — R/WC. 0 = Software clears this bit by writing a 1 to it. 1 = This bit is set when a Magic Packet is received regardless of the Magic Packet wake-up disable bit in the configuration command and the PME Enable bit in the Power Management Control/Status Register.
5	Interesting Packet — R/WC. 0 = Software clears this bit by writing a 1 to it. 1 = This bit is set when an "interesting" packet is received. Interesting packets are defined by the LAN controller packet filters.
4:3	Reserved
2	ASF Enabled — RO. This bit is set to 1 when the LAN controller is in ASF mode.
1	TCO Request — R/WC. 0 = Software clears this bit by writing a 1 to it. 1 = This bit is set to 1b when the LAN controller is busy with TCO activity.
0	PME Status — R/WC. This bit is a reflection of the PME Status bit in the Power Management Control/Status Register (PMCSR). 0 = Software clears this bit by writing a 1 to it. This also clears the PME Status bit in the PMCSR and de-asserts the PME signal. 1 = Set upon a wake-up event, independent of the PME Enable bit.

8.2.11 GENCNTL—General Control Register (LAN Controller—B1:D8:F0)

Offset Address: 1Ch Attribute: R/W
 Default Value: 00h Size: 8 bits

Bit	Description
7:4	Reserved. These bits should be set to 0000b.
3	LAN Connect Software Reset — R/W. 0 = Cleared by software to begin normal LAN Connect operating mode. Software must not attempt to access the LAN Connect interface for at least 1ms after clearing this bit. 1 = Software can set this bit to force a reset condition on the LAN Connect interface.
2	Reserved. This bit should be set to 0.
1	Deep Power-Down on Link Down Enable — R/W. 0 = Disable 1 = Enable. The ICH6's internal LAN controller may enter a deep power-down state (sub-3 mA) in the D2 and D3 power states while the link is down. In this state, the LAN controller does not keep link integrity. This state is not supported for point-to-point connection of two end stations.
0	Reserved

8.2.12 GENSTA—General Status Register (LAN Controller—B1:D8:F0)

Offset Address: 1Dh Attribute: RO
 Default Value: 00h Size: 8 bits

Bit	Description
7:3	Reserved
2	Duplex Mode — RO. This bit indicates the wire duplex mode. 0 = Half duplex 1 = Full duplex
1	Speed — RO. This bit indicates the wire speed. 0 = 10 Mb/s 1 = 100 Mb/s
0	Link Status Indication — RO. This bit indicates the status of the link. 0 = Invalid 1 = Valid

8.2.13 SMB_PCI—SMB via PCI Register (LAN Controller—B1:D8:F0)

Offset Address: 1Fh Attribute: R/W, RO
 Default Value: 27h Size: 8 bits

Software asserts SREQ when it wants to isolate the PCI-accessible SMBus to the ASF registers/commands. It waits for SGNT to be asserted. At this point SCLI, SDAO, SCLO, and SDAI can be toggled/read to force ASF controller SMBus transactions without affecting the external SMBus. After all operations are completed, the bus is returned to idle (SCLO=1b, SDAO=1b, SCLI=1b, SDAI=1b), SREQ is released (written 0b). Then SGNT goes low to indicate released control of the bus. The logic in the ASF controller only asserts or de-asserts SGNT at times when it determines that it is safe to switch (all SMBuses that are switched in/out are idle).

When in isolation mode (SGNT=1), software can access the ICH6 SMBus slaves that allow configuration without affecting the external SMBus. This includes configuration register accesses and ASF command accesses. However, this capability is not available to the external TCO controller. When SGNT=0, the bit-banging and reads are reflected on the main SMBus and the PCISML_SDA0, PCISML_SCL0 read only bits.

Bit	Description
7:6	Reserved
5	PCISML_SCLO — RO. SMBus Clock from the ASF controller.
4	PCISML_SGNT — RO. SMBus Isolation Grant from the ASF controller.
3	PCISML_SREQ — R/W. SMBus Isolation Request to the ASF controller.
2	PCISML_SDAO — RO. SMBus Data from the ASF controller.
1	PCISML_SDAI — R/W. SMBus Data to the ASF controller.
0	PCISML_SCLI — R/W. SMBus Clock to the ASF controller.

8.2.14 Statistical Counters (LAN Controller—B1:D8:F0)

The ICH6's integrated LAN controller provides information for network management statistics by providing on-chip statistical counters that count a variety of events associated with both transmit and receive. The counters are updated by the LAN controller when it completes the processing of a frame (that is, when it has completed transmitting a frame on the link or when it has completed receiving a frame). The Statistical Counters are reported to the software on demand by issuing the Dump Statistical Counters command or Dump and Reset Statistical Counters command in the SCB Command Unit Command (CUC) field.

Table 8-6. Statistical Counters (Sheet 1 of 2)

ID	Counter	Description
0	Transmit Good Frames	This counter contains the number of frames that were transmitted properly on the link. It is updated only after the actual transmission on the link is completed, not when the frame was read from memory as is done for the Transmit Command Block status.
4	Transmit Maximum Collisions (MAXCOL) Errors	This counter contains the number of frames that were not transmitted because they encountered the configured maximum number of collisions.
8	Transmit Late Collisions (LATECOL) Errors	This counter contains the number of frames that were not transmitted since they encountered a collision later than the configured slot time.
12	Transmit Underrun Errors	A transmit underrun occurs because the system bus cannot keep up with the transmission. This counter contains the number of frames that were either not transmitted or retransmitted due to a transmit DMA underrun. If the LAN controller is configured to retransmit on underrun, this counter may be updated multiple times for a single frame.
16	Transmit Lost Carrier Sense (CRS)	This counter contains the number of frames that were transmitted by the LAN controller despite the fact that it detected the de-assertion of CRS during the transmission.
20	Transmit Deferred	This counter contains the number of frames that were deferred before transmission due to activity on the link.
24	Transmit Single Collisions	This counter contains the number of transmitted frames that encountered one collision.
28	Transmit Multiple Collisions	This counter contains the number of transmitted frames that encountered more than one collision.
32	Transmit Total Collisions	This counter contains the total number of collisions that were encountered while attempting to transmit. This count includes late collisions and frames that encountered MAXCOL.
36	Receive Good Frames	This counter contains the number of frames that were received properly from the link. It is updated only after the actual reception from the link is completed and all the data bytes are stored in memory.
40	Receive CRC Errors	This counter contains the number of aligned frames discarded because of a CRC error. This counter is updated, if needed, regardless of the Receive Unit state. The Receive CRC Errors counter is mutually exclusive of the Receive Alignment Errors and Receive Short Frame Errors counters.
44	Receive Alignment Errors	This counter contains the number of frames that are both misaligned (for example, CRS de-asserts on a non-octal boundary) and contain a CRC error. The counter is updated, if needed, regardless of the Receive Unit state. The Receive Alignment Errors counter is mutually exclusive of the Receive CRC Errors and Receive Short Frame Errors counters.

Table 8-6. Statistical Counters (Sheet 2 of 2)

ID	Counter	Description
48	Receive Resource Errors	This counter contains the number of good frames discarded due to unavailability of resources. Frames intended for a host whose Receive Unit is in the No Resources state fall into this category. If the LAN controller is configured to Save Bad Frames and the status of the received frame indicates that it is a bad frame, the Receive Resource Errors counter is not updated.
52	Receive Overrun Errors	This counter contains the number of frames known to be lost because the local system bus was not available. If the traffic problem persists for more than one frame, the frames that follow the first are also lost; however, because there is no lost frame indicator, they are not counted.
56	Receive Collision Detect (CDT)	This counter contains the number of frames that encountered collisions during frame reception.
60	Receive Short Frame Errors	This counter contains the number of received frames that are shorter than the minimum frame length. The Receive Short Frame Errors counter is mutually exclusive to the Receive Alignment Errors and Receive CRC Errors counters. A short frame will always increment only the Receive Short Frame Errors counter.
64	Flow Control Transmit Pause	This counter contains the number of Flow Control frames transmitted by the LAN controller. This count includes both the Xoff frames transmitted and Xon (PAUSE(0)) frames transmitted.
68	Flow Control Receive Pause	This counter contains the number of Flow Control frames received by the LAN controller. This count includes both the Xoff frames received and Xon (PAUSE(0)) frames received.
72	Flow Control Receive Unsupported	This counter contains the number of MAC Control frames received by the LAN controller that are not Flow Control Pause frames. These frames are valid MAC control frames that have the predefined MAC control Type value and a valid address but has an unsupported opcode.
76	Receive TCO Frames	This counter contains the number of TCO packets received by the LAN controller.
78	Transmit TCO Frames	This counter contains the number of TCO packets transmitted.

The Statistical Counters are initially set to 0 by the ICH6's integrated LAN controller after reset. They cannot be preset to anything other than 0. The LAN controller increments the counters by internally reading them, incrementing them and writing them back. This process is invisible to the processor and PCI bus. In addition, the counters adhere to the following rules:

- The counters are wrap-around counters. After reaching FFFFFFFFh the counters wrap around to 0.
- The LAN controller updates the required counters for each frame. It is possible for more than one counter to be updated as multiple errors can occur in a single frame.
- The counters are 32 bits wide and their behavior is fully compatible with the IEEE 802.1 standard. The LAN controller supports all mandatory and recommend statistics functions through the status of the receive header and directly through these Statistical Counters.

The processor can access the counters by issuing a Dump Statistical Counters SCB command. This provides a “snapshot”, in main memory, of the internal LAN controller statistical counters. The LAN controller supports 21 counters. The dump could consist of the either 16, 19, or all 21 counters, depending on the status of the Extended Statistics Counters and TCO Statistics configuration bits in the Configuration command.

8.3 ASF Configuration Registers (LAN Controller—B1:D8:F0)

Table 8-7. ASF PCI Configuration Register Address Map (LAN Controller—B1:D8:F0)

Offset	Mnemonic	Register Name	Default	Type
E0h	ASF_RID	ASF Revision Identification	ECh	RO
E1h	SMB_CNTL	SMBus Control	40h	R/W
E2h	ASF_CNTL	ASF Control	00h	R/W, RO
E3h	ASF_CNTL_EN	ASF Control Enable	00h	R/W
E4h	ENABLE	Enable	00h	R/W
E5h	APM	APM	08h	R/W
E6–E7h	—	Reserved	—	—
E8h	WTIM_CONF	Watchdog Timer Configuration	00h	R/W
E9h	HEART_TIM	Heartbeat Timer	02h	R/W
EAh	RETRAN_INT	Retransmission Interval	02h	R/W
EBh	RETRAN_PCL	Retransmission Packet Count Limit	03h	R/W
ECh	ASF_WTIM1	ASF Watchdog Timer 1	01h	R/W
EDh	ASF_WTIM2	ASF Watchdog Timer 2	00h	R/W
F0h	PET_SEQ1	PET Sequence 1	00h	R/W
F1h	PET_SEQ2	PET Sequence 2	00h	R/W
F2h	STA	Status	40h	R/W
F3h	FOR_ACT	Forced Actions	02h	R/W
F4h	RMCP_SNUM	RMCP Sequence Number	00h	R/W
F5h	SP_MODE	Special Modes	x0h	R/WC, RO
F6h	INPOLL_TCONF	Inter-Poll Timer Configuration	10h	R/W
F7h	PHIST_CLR	Poll History Clear	00h	R/WC
F8h	PMSK1	Polling Mask 1	XXh	R/W
F9h	PMSK2	Polling Mask 2	XXh	R/W
FAh	PMSK3	Polling Mask 3	XXh	R/W
FBh	PMSK4	Polling Mask 4	XXh	R/W
FCh	PMSK5	Polling Mask 5	XXh	R/W
FDh	PMSK6	Polling Mask 6	XXh	R/W
FEh	PMSK7	Polling Mask 7	XXh	R/W
FFh	PMSK8	Polling Mask 8	XXh	R/W

8.3.1 ASF RID—ASF Revision Identification Register (LAN Controller—B1:D8:F0)

Offset Address: E0h Attribute: RO
 Default Value: ECh Size: 8 bits

Bit	Description
7:3	ASF ID — RO. Hardwired to 11101 to identify the ASF controller.
2:0	ASF Silicon Revision — RO. This field provides the silicon revision.

8.3.2 SMB_CNTL—SMBus Control Register (LAN Controller—B1:D8:F0)

Offset Address: E1h Attribute: R/W
 Default Value: 40h Size: 8 bits

This register is used to control configurations of the SMBus ports.

Bit	Description
7	SMBus Remote Control ASF Enable (SMB_RCASF) — R/W. 0 = Legacy descriptors and operations are used. 1 = ASF descriptors and operations are used.
6	SMBus ARP Enable (SMB_ARPEN) — R/W. 0 = Disable. 1 = ASF enables the SMBus ARP protocol.
5:4	Reserved
3	SMBus Drive Low (SMB_DRVLO) — R/W. 0 = ASF will not drive the main SMBus signals low while PWR_GOOD = 0. 1 = ASF will drive the main SMBus signals low while PWR_GOOD = 0.
2:0	Reserved

8.3.3 ASF_CNTL—ASF Control Register (LAN Controller—B1:D8:F0)

Offset Address: E2h Attribute: R/W, RO
 Default Value: 00h Size: 8 bits

This register contains enables for special modes and SOS events. CTL_PWRLS should be set if ASF should be expecting a power loss due to software action. Otherwise, an EEPROM reload will happen when the power is lost.

Bit	Description
7	SMBus Hang SOS Enable (CTL_SMBHG) — R/W. 0 = Disable 1 = Enables SMBus Hang SOS to be sent.
6	Watchdog SOS Enable (CTL_WDG) — R/W. 0 = Disable. 1 = Enables Watchdog SOS to be sent.
5	Link Loss SOS Enable (CTL_LINK) — R/W. 0 = Disable. 1 = Enables Link Loss SOS to be sent.
4	OS Hung Status (CTL_OSHUNG) — RO. 1 = This bit will be set to 1 when ASF has detected a Watchdog Expiration. NOTE: This condition is only clearable by a PCI RST# assertion (system reset).
3	Power-Up SOS Enable (CTL_PWRUP) — R/W. 0 = Disable. 1 = Enables Power-Up SOS to be sent.
2	Reserved
1	Receive ARP Enable (CTL_RXARP) — R/W. The LAN controller interface provides a mode where all packets can be requested. 0 = Disable. 1 = Enable. ASF requests all packets when doing a Receive Enable. This is necessary in LAN controller to get ARP packets. NOTE: Changes to this bit will not take effect until the next Receive Enable command to the LAN.
0	Power Loss OK (CTL_PWRLS) — R/W. 0 = Power Loss will reload EEPROM 1 = Power Loss will not reload EEPROM

8.3.4 ASF_CNTL_EN—ASF Control Enable Register (ASF Controller—B1:D8:F0)

Offset Address: E3h Attribute: R/W
 Default Value: 00h Size: 8 bits

This register is used to enable global processing as well as polling. GLOBAL ENABLE controls all of the SMBus processing and packet creation.

Bit	Description
7	Global Enable (CENA_ALL) — R/W. 0 = Disable 1 = All control and polling enabled
6	Receive Enable (CENA_RX) — R/W. 0 = Disable 1 = TCO Receives enabled.
5	Transmit Enable (CENA_TX) — R/W. 0 = Disable 1 = SOS and RMCP Transmits enabled
4	ASF Polling Enable (CENA_APOL) — R/W. 0 = Disable 1 = Enable ASF Sensor Polling.
3	Legacy Polling Enable (CENA_LPOL) — R/W. 0 = Disable 1 = Enable Legacy Sensor Polling.
2:0	Number of Legacy Poll Devices (CENA_NLPOL) — R/W. This 3-bit value indicates how many of the eight possible polling descriptors are active. 000 = First polling descriptor is active. 001 = First two polling descriptors are active. ... 111 = Enables all eight descriptors.

8.3.6 APM—APM Register (ASF Controller—B1:D8:F0)

Offset Address: E5h Attribute: R/W
Default Value: 08h Size: 8 bits

This register contains the configuration bit to disable state-based security.

Bit	Description
7:4	Reserved
3	Disable State-based Security (APM_DISSB) — R/W. 0 = State-based security on OSHung is enabled. 1 = State-based security is disabled and actions are not gated by OSHung.
2:0	Reserved

8.3.7 WTIM_CONF—Watchdog Timer Configuration Register (ASF Controller—B1:D8:F0)

Offset Address: E8h Attribute: R/W
Default Value: 00h Size: 8 bits

This register contains a single bit that enables the Watchdog timer. This bit is not intended to be accessed by software, but should be configured appropriately in the EEPROM location for this register default. The bit provides real-time control for enabling/disabling the Watchdog timer. When set the timer will count down. When cleared the counter will stop. Timer Start ASF SMBus messages will set this bit. Timer Stop ASF SMBus transactions will clear this bit.

Bit	Description
7:1	Reserved
0	Timer Enable (WDG_ENA) — R/W. 0 = Disable 1 = Enable Counter

8.3.8 HEART_TIM—Heartbeat Timer Register (ASF Controller—B1:D8:F0)

Offset Address: E9h Attribute: R/W
Default Value: 02h Size: 8 bits

The HeartBeat Timer register implements the heartbeat timer. This defines the period of the heartbeats packets. It contains a down counting value when enabled and the time-out value when the counter is disabled. The timer can be configured and enabled in a single write.

Note: The heartbeat timer controls the heartbeat status packet frequency. The timer is free-running and the configured time is only valid from one heartbeat to the next. When enabled by software, the next heartbeat may occur in any amount of time less than the configured time.

Bit	Description
7:1	Heartbeat Timer Value (HBT_VAL) — R/W. Heartbeat timer load value in 10.7-second resolution. This field can only be written while the timer is disabled. (10.7 sec – 23 min range). Read as load value when HBT_ENA=0. Read as decrementing value when HBT_ENA=1. Timer resolution is 10.7 seconds. A value of 00h is invalid.
0	Timer Enable (HBT_ENA) — R/W. 0 = Disable 1 = Enable / Reset Counter

8.3.9 RETRAN_INT—Retransmission Interval Register (ASF Controller—B1:D8:F0)

Offset Address: EAh Attribute: R/W
Default Value: 02h Size: 8 bits

This register implements the retransmission timer. This is the time between packet transmissions for multiple packets due to a SOS.

Bit	Description
7:1	Retransmit Timer Value (RTM_VAL) — R/W. Retransmit timer load value 2.7 second resolution. This field is always writable (2.7 sec – 5.7 min range). Timer is accurate to +0 seconds, – 0.336 seconds. Reads always show the load value (decrement value never shown). A value of 00h is invalid.
0	Reserved

8.3.10 RETRAN_PCL—Retransmission Packet Count Limit Register (ASF Controller—B1:D8:F0)

Offset Address: EBh Attribute: R/W
 Default Value: 03h Size: 8 bits

This register defines the number of packets that are to be sent due to an SOS.

Bit	Description
7:0	Retransmission Packet Count Limit (RPC_VAL) — R/W. This field provides the number of packets to be sent for all SOS packets that require retransmissions.

8.3.11 ASF_WTIM1—ASF Watchdog Timer 1 Register (ASF Controller—B1:D8:F0)

Offset Address: ECh Attribute: R/W
 Default Value: 01h Size: 8 bits

This register is used to load the low byte of the timer. When read, it reports the decrementing value. This register is not intended to be written by software, but should be configured appropriately in the EEPROM location for this register default. Timer Start ASF SMBus transactions will load values into this register. Once the timer has expired (0000h), the timer will be disabled (EDG_ENA=0b) and the value in this register will remain at 00h until otherwise changed.

Bit	Description
7:0	ASF Watchdog Timer 1 (AWD1_VAL) — R/W. This field provides the low byte of the ASF 1-second resolution timer. The timer is accurate to +0 seconds, -0.336 seconds.

8.3.12 ASF_WTIM2—ASF Watchdog Timer 2 Register (ASF Controller—B1:D8:F0)

Offset Address: EDh Attribute: R/W
 Default Value: 00h Size: 8 bits

This register is used to load the high byte of the timer. When read, it reports the decrementing value. This register is not intended to be written by software, but should be configured appropriately in the EEPROM location for this register default. Timer Start ASF SMBus transactions will load values into this register. Once the timer has expired (0000h), the timer will be disabled (EDG_ENA=0b) and the value in this register will remain at 00h until otherwise changed.

Bit	Description
7:0	ASF Watchdog Timer 2 (AWD2_VAL) — R/W. This field provides the high byte of the ASF 1-second resolution timer. The timer is accurate to +0 seconds, -0.336 seconds.

8.3.13 PET_SEQ1—PET Sequence 1 Register (ASF Controller—B1:D8:F0)

Offset Address:	F0h	Attribute:	R/W
Default Value:	00h	Size:	8 bits

This register (low byte) holds the current value of the PET sequence number. This field is read/write-able through this register, and is also automatically incremented by the hardware when new PET packets are generated. By policy, software should not write to this register unless transmission is disabled.

Bit	Description
7:0	PET Sequence Byte 1 (PSEQ1_VAL) — R/W. This field provides the low byte.

8.3.14 PET_SEQ2—PET Sequence 2 Register (ASF Controller—B1:D8:F0)

Offset Address:	F1h	Attribute:	R/W
Default Value:	00h	Size:	8 bits

This register (high byte) holds the current value of the PET sequence number. This field is read/write-able through this register, and is also automatically incremented by the hardware when new PET packets are generated. By policy, software should not write to this register unless transmission is disabled.

Bit	Description
7:0	PET Sequence Byte 2 (PSEQ2_VAL) — R/W. This field provides the high byte.



8.3.15 STA—Status Register (ASF Controller—B1:D8:F0)

Offset Address: F2h Attribute: R/W
Default Value: 40h Size: 8 bits

This register gives status indication about several aspects of ASF.

Bit	Description
7	EEPROM Loading (STA_LOAD) — R/W. EEPROM defaults are in the process of being loaded when this bit is a 1.
6	EEPROM Invalid Checksum Indication (STA_ICRC) — R/W. This bit should be read only after the EEC_LOAD bit is a 0. 0 = Valid 1 = Invalid checksum detected for ASF portion of the EEPROM.
5:4	Reserved
3	Power Cycle Status (STA_CYCLE) — R/W. 0 = Software clears this bit by writing a 1. 1 = This bit is set when a Power Cycle operation has been issued.
2	Power Down Status (STA_DOWN) — R/W. 0 = Software clears this bit by writing a 1 1 = This bit is set when a Power Down operation has been issued.
1	Power Up Status (STA_UP) — R/W. 0 = Software clears this bit by writing a 1 1 = This bit is set when a Power Up operation has been issued.
0	System Reset Status (STA_RST) — R/W. 0 = Software clears this bit by writing a 1 1 = This bit is set when a System Reset operation has been issued.

8.3.16 FOR_ACT—Forced Actions Register (ASF Controller—B1:D8:F0)

Offset Address: F3h Attribute: R/W
Default Value: 02h Size: 8 bits

This register contains many different forcible actions including APM functions, flushing internal pending SOS operations, software SOS operations, software reset, and EEPROM reload. Writes to this register must only set one bit per-write. Setting multiple bits in a single write can have indeterminate results.

Note: For bits in this register, writing a 1 invokes the operation. The bits self-clear immediately.

Bit	Description
7	Software Reset (FRC_RST) — R/W. This bit is used to reset the ASF controller. It performs the equivalent of a hardware reset and re-read the EEPROM. This bit self-clears immediately. Software should wait for the EEC_LOAD bit to clear.
6	Force EEPROM Reload (FRC_EELD) — R/W. Force Reload of EEPROM without affect current monitoring state of the ASF controller. This bit self-clears immediately. NOTE: Software registers in EEPROM are not loaded by this action. Software should disable the ASF controller before issuing this command and wait for STA_LOAD to clear before enabling again.
5	Flush SOS (FRC_FLUSH) — R/W. This bit is used to flush any pending SOSes or history internal to the ASF controller. This is necessary because the Status register only shows events that have happened as opposed to SOS events sent. Also, the history bits in the ASF controller are not software visible. Self-clears immediately.
4	Reserved
3	Force APM Power Cycle (FRC_ACYC) — R/W. This mode forces the ASF controller to initiate a power cycle to the system. The bit self-clears immediately.
2	Force APM Hard Power Down (FRC_AHDN) — R/W. This mode forces the ASF controller to initiate a hard power down of the system immediately. The bit self-clears immediately.
1	Clear ASF Polling History (FRC_CLRAPOL) — R/W. Writing a 1b to this bit position will clear the Poll History associated with all ASF Polling. Writing a 0b has no effect. This bit self-clears immediately.
0	Force APM Reset (FRC_ARST) — R/W. This mode forces the ASF controller to initiate a hard reset of the system immediately. The bit self-clears immediately.

8.3.17 RMCP_SNUM—RMCP Sequence Number Register (ASF Controller—B1:D8:F0)

Offset Address: F4h Attribute: R/W
Default Value: 00h Size: 8 bits

This register is a means for software to read the current sequence number that hardware is using in RMCP packets. Software can also change the value. Software should only write to this register while the GLOBAL_ENABLE is off.

Bit	Description
7:0	RMCP Sequence Number (RSEQ_VAL) — R/W. This is the current sequence number of the RMCP packet being sent or the sequence number of the next RMCP packet to be sent. This value can be set by software. At reset, it defaults to 00h. If the sequence number is not FFh, the ASF controller will automatically increment this number by one (or rollover to 00h if incrementing from FEh) after a successful RMCP packet transmission.

8.3.18 SP_MODE—Special Modes Register (ASF Controller—B1:D8:F0)

Offset Address: F5h Attribute: R/WC, RO
 Default Value: x0h Size: 8 bits

The register contains miscellaneous functions.

Bit	Description
7	SMBus Activity Bit (SPE_ACT) — RO. 1 = ASF controller is active with a SMBus transaction. This is an indicator to software that the ASF controller is still processing commands on the SMBus.
6	Watchdog Status (SPE_WDG) — R/WC. 0 = Software clears this bit by writing a 1 to it. 1 = This bit is set when a watchdog expiration occurs.
5	Link Loss Status (SPE_LNK) — R/WC. 0 = Software clears this bit by writing a 1 to it. 1 = This bit is set when a link loss occurs (link is down for more than 5 seconds).
4:0	Reserved

8.3.19 INPOLL_TCONF—Inter-Poll Timer Configuration Register (ASF Controller—B1:D8:F0)

Offset Address: F6h Attribute: R/W
 Default Value: 10h Size: 8 bits

This register is used to load and hold the value (in increments of 5 ms) for the polling timer. This value determines how often the ASF polling timer expires which determines the minimum idle time between sensor polls.

Bit	Description
7:0	Inter-Poll Timer Configuration (IPTC_VAL) — R/W. This field identifies the time, in 5.24 ms units that the ASF controller will wait between the end of the one ASF Poll Alert Message to start on the next. The value 00h is illegal and unsupported.

8.3.20 PHIST_CLR—Poll History Clear Register (ASF Controller—B1:D8:F0)

Offset Address: F7h Attribute: R/WC
 Default Value: 00h Size: 8 bits

This register is used to clear the history of the Legacy Poll operations. ASF maintains history of the last poll data for each Legacy Poll operation to compare against the current poll to detect changes. By setting the appropriate bit, the history for that Legacy Poll is cleared to 0s.

Bit	Description
7	Clear Polling Descriptor 8 History (PHC_POLL8) — R/WC. Writing a 1b to this bit position will clear the Poll History associated with Polling Descriptor #8. Writing a 0b has no effect.
6	Clear Polling Descriptor 7 History (PHC_POLL7) — R/WC. Writing a 1b to this bit position will clear the Poll History associated with Polling Descriptor #7. Writing a 0b has no effect.
5	Clear Polling Descriptor 6 History (PHC_POLL6) — R/WC. Writing a 1b to this bit position will clear the Poll History associated with Polling Descriptor #6. Writing a 0b has no effect.
4	Clear Polling Descriptor 5 History (PHC_POLL5) — R/WC. Writing a 1b to this bit position will clear the Poll History associated with Polling Descriptor #5. Writing a 0b has no effect.
3	Clear Polling Descriptor 4 History (PHC_POLL4) — R/WC. Writing a 1b to this bit position will clear the Poll History associated with Polling Descriptor #4. Writing a 0b has no effect.
2	Clear Polling Descriptor 3 History (PHC_POLL3) — R/WC. Writing a 1b to this bit position will clear the Poll History associated with Polling Descriptor #3. Writing a 0b has no effect.
1	Clear Polling Descriptor 2 History (PHC_POLL2) — R/WC. Writing a 1b to this bit position will clear the Poll History associated with Polling Descriptor #2. Writing a 0b has no effect.
0	Clear Polling Descriptor 1 History (PHC_POLL1) — R/WC. Writing a 1b to this bit position will clear the Poll History associated with Polling Descriptor #1. Writing a 0b has no effect.

8.3.21 PMSK1—Polling Mask 1 Register (ASF Controller—B1:D8:F0)

Offset Address: F8h Attribute: R/W
 Default Value: XXh Size: 8 bits

This register provides software an interface for the Polling #1 Data Mask.

Bit	Description
7:0	Polling Mask for Polling Descriptor #1 (POL1_MSK) — R/W. This field is used to read and write the data mask for Polling Descriptor #1. Software should only access this register when the ASF controller is GLOBAL DISABLED.

8.3.22 PMSK2—Polling Mask 2 Register (ASF Controller—B1:D8:F0)

Offset Address: F9h Attribute: R/W
 Default Value: XXh Size: 8 bits

This register provides software an interface for the Polling #2 Data Mask.

Bit	Description
7:0	Polling Mask for Polling Descriptor #2 (POL2_MSK) — R/W. This field is used to read and write the data mask for Polling Descriptor #2. Software should only access this register when the ASF controller is GLOBAL DISABLED.

8.3.23 PMSK3—Polling Mask 3 Register (ASF Controller—B1:D8:F0)

Offset Address: FAh Attribute: R/W
 Default Value: XXh Size: 8 bits

This register provides software an interface for the Polling #3 Data Mask.

Bit	Description
7:0	Polling Mask for Polling Descriptor #3 (POL3_MSK) — R/W. This register is used to read and write the data mask for Polling Descriptor #3. Software should only access this register when the ASF controller is GLOBAL DISABLED.

8.3.24 PMSK4—Polling Mask 4 Register (ASF Controller—B1:D8:F0)

Offset Address: FBh Attribute: R/W
 Default Value: XXh Size: 8 bits

This register provides software an interface for the Polling #4 Data Mask.

Bit	Description
7:0	Polling Mask for Polling Descriptor #4 (POL4_MSK) — R/W. This register is used to read and write the data mask for Polling Descriptor #4. Software should only access this register when the ASF controller is GLOBAL DISABLED.



9 PCI-to-PCI Bridge Registers (D30:F0)

The ICH6 PCI bridge resides in PCI Device 30, Function 0 on bus #0. This implements the buffering and control logic between PCI and the backbone. The arbitration for the PCI bus is handled by this PCI device.

9.1 PCI Configuration Registers (D30:F0)

Note: Address locations that are not shown should be treated as Reserved (see [Section 6.2](#) for details).

Table 9-1. PCI Bridge Register Address Map (PCI-PCI—D30:F0) (Sheet 1 of 2)

Offset	Mnemonic	Register Name	Default	Type
00–01h	VID	Vendor Identification	8086h	RO
02–03h	DID	Device Identification	244Eh (Desktop) 2448h (ICH6-M)	RO
04–05h	PCICMD	PCI Command	0000h	R/W, RO
06–07h	PSTS	PCI Status	0010h	R/WC, RO
08h	RID	Revision Identification	See register description.	RO
09-0Bh	CC	Class Code	060401h	RO
0Dh	PMLT	Primary Master Latency Timer	00h	RO
0Eh	HEADTYP	Header Type	81h	RO
18-1Ah	BNUM	Bus Number	000000h	R/W, RO
1Bh	SMLT	Secondary Master Latency Timer	00h	R/W, RO
1C-1Dh	IOBASE_LIMIT	I/O Base and Limit	0000h	R/W, RO
1E–1Fh	SECSTS	Secondary Status	0280h	R/WC, RO
20–23h	MEMBASE_LIMIT	Memory Base and Limit	00000000h	R/W, RO
24–27h	PREF_MEM_BASE_LIMIT	Prefetchable Memory Base and Limit	00010001h	R/W, RO
28–2Bh	PMBU32	Prefetchable Memory Upper 32 Bits	00000000h	R/W
2C–2Fh	PMLU32	Prefetchable Memory Limit Upper 32 Bits	00000000h	R/W
34h	CAPP	Capability List Pointer	50h	RO
3C-3Dh	INTR	Interrupt Information	0000h	R/W, RO
3E–3Fh	BCTRL	Bridge Control	0000h	R/WC, RO
40–41h	SPDH	Secondary PCI Device Hiding	00h	R/W, RO

Table 9-1. PCI Bridge Register Address Map (PCI-PCI—D30:F0) (Sheet 2 of 2)

Offset	Mnemonic	Register Name	Default	Type
42h	PDPR	PCI Decode Policy Register	00h	R/W
44-47h	DTC	Delayed Transaction Control	00000000h	R/W, RO
48-4B	BTS	Bridge Proprietary Status	00000000h	R/WC, RO
4C-4F	BPC	Bridge Policy Configuration	00000000h	R/W RO
50-51h	SVCAP	Subsystem Vendor Capability Pointer	000Dh	RO
54-57	SVID	Subsystem Vendor IDs	00000000	R/WO

9.1.1 VID— Vendor Identification Register (PCI-PCI—D30:F0)

Offset Address: 00-01h
 Default Value: 8086h

Attribute: RO
 Size: 16 bits

Bit	Description
15:0	Vendor ID — RO. This is a 16-bit value assigned to Intel. Intel VID = 8086h.

9.1.2 DID— Device Identification Register (PCI-PCI—D30:F0)

Offset Address: 02-03h
 Default Value: 2448h (Mobile)
 244Eh (Desktop)

Attribute: RO
 Size: 16 bits

Bit	Description
15:0	Device ID — RO. This is a 16-bit value assigned to the PCI bridge. Mobile = 2448h (ICH6-M) Desktop = 244Eh (ICH6, ICH6R)

9.1.3 PCICMD—PCI Command (PCI-PCI—D30:F0)

Offset Address:	04–05h	Attribute:	R/W, RO
Default Value:	0000h	Size:	16 bits

Bit	Description
15:11	Reserved
10	Interrupt Disable (ID) — RO. Hardwired to 0. The PCI bridge has no interrupts to disable
9	Fast Back to Back Enable (FBE) — RO. Hardwired to 0, per the <i>PCI Express* Base Specification, Revision 1.0a</i> .
8	SERR# Enable (SERR_EN) — R/W. 0 = Disable. 1 = Enable the ICH6 to generate an NMI (or SMI# if NMI routed to SMI#) when the D30:F0 SSE bit (offset 06h, bit 14) is set.
7	Wait Cycle Control (WCC) — RO. Hardwired to 0, per the <i>PCI Express* Base Specification, Revision 1.0a</i> .
6	Parity Error Response (PER) — R/W. 0 = The ICH6 ignores parity errors on the PCI bridge. 1 = The ICH6 will set the SSE bit (D30:F0, offset 06h, bit 14) when parity errors are detected on the PCI bridge.
5	VGA Palette Snoop (VPS) — RO. Hardwired to 0, per the <i>PCI Express* Base Specification, Revision 1.0a</i> .
4	Memory Write and Invalidate Enable (MWE) — RO. Hardwired to 0, per the <i>PCI Express* Base Specification, Revision 1.0a</i>
3	Special Cycle Enable (SCE) — RO. Hardwired to 0, per the <i>PCI Express* Base Specification, Revision 1.0a</i> and the <i>PCI-to-PCI Bridge Specification</i> .
2	Bus Master Enable (BME) — R/W. 0 = Disable 1 = Enable. Allows the PCI-to-PCI bridge to accept cycles from PCI.
1	Memory Space Enable (MSE) — R/W. Controls the response as a target for memory cycles targeting PCI. 0 = Disable 1 = Enable
0	I/O Space Enable (IOSE) — R/W. Controls the response as a target for I/O cycles targeting PCI. 0 = Disable 1 = Enable

9.1.4 PSTS—PCI Status Register (PCI-PCI—D30:F0)

Offset Address: 06–07h Attribute: R/WC, RO
 Default Value: 0010h Size: 16 bits

Note: For the writable bits, software must write a 1 to clear bits that are set. Writing a 0 to the bit has no effect.

Bit	Description
15	<p>Detected Parity Error (DPE) — R/WC.</p> <p>0 = Parity error Not detected. 1 = Indicates that the ICH6 detected a parity error on the internal backbone. This bit gets set even if the Parity Error Response bit (D30:F0:04 bit 6) is not set.</p>
14	<p>Signaled System Error (SSE) — R/WC. Several internal and external sources of the bridge can cause SERR#. The first class of errors is parity errors related to the backbone. The PCI bridge captures generic data parity errors (errors it finds on the backbone) as well as errors returned on backbone cycles where the bridge was the master. If either of these two conditions is met, and the primary side of the bridge is enabled for parity error response, SERR# will be captured as shown below.</p> <div data-bbox="597 827 1271 961" style="border: 1px solid black; padding: 5px; margin-bottom: 10px;"> </div> <p>As with the backbone, the PCI bus captures the same sets of errors. The PCI bridge captures generic data parity errors (errors it finds on PCI) as well as errors returned on PCI cycles where the bridge was the master. If either of these two conditions is met, and the secondary side of the bridge is enabled for parity error response, SERR# will be captured as shown below.</p> <div data-bbox="625 1071 1247 1251" style="border: 1px solid black; padding: 5px; margin-bottom: 10px;"> </div> <p>The final class of errors is system bus errors. There are three status bits associated with system bus errors, each with a corresponding enable. The diagram capturing this is shown below.</p> <div data-bbox="609 1312 1263 1577" style="border: 1px solid black; padding: 5px; margin-bottom: 10px;"> </div> <p>After checking for the three above classes of errors, an SERR# is generated, and PSTS.SSE logs the generation of SERR#, if CMD.SEE (D30:F0:04, bit 8) is set, as shown below.</p> <div data-bbox="592 1640 1279 1839" style="border: 1px solid black; padding: 5px;"> </div>

9.1.7 PMLT—Primary Master Latency Timer Register (PCI-PCI—D30:F0)

Offset Address: 0Dh Attribute: RO
 Default Value: 00h Size: 8 bits

Bit	Description
7:3	Master Latency Timer Count (MLTC) — RO. Reserved per the <i>PCI Express* Base Specification, Revision 1.0a</i> .
2:0	Reserved

9.1.8 HEADTYP—Header Type Register (PCI-PCI—D30:F0)

Offset Address: 0Eh Attribute: RO
 Default Value: 81h Size: 8 bits

Bit	Description																				
7	Multi-Function Device (MFD) — RO. The value reported here depends upon the state of the AC '97 function hide (FD) register (Chipset Configuration Registers:Offset 3418h), per the following table: <table border="1" data-bbox="454 945 844 1102"> <thead> <tr> <th></th> <th>FD.AAD</th> <th>FD.AMD</th> <th>MFD</th> </tr> </thead> <tbody> <tr> <td>0</td> <td>0</td> <td>0</td> <td>1</td> </tr> <tr> <td>0</td> <td>0</td> <td>1</td> <td>1</td> </tr> <tr> <td>1</td> <td>1</td> <td>0</td> <td>1</td> </tr> <tr> <td>1</td> <td>1</td> <td>1</td> <td>0</td> </tr> </tbody> </table>		FD.AAD	FD.AMD	MFD	0	0	0	1	0	0	1	1	1	1	0	1	1	1	1	0
	FD.AAD	FD.AMD	MFD																		
0	0	0	1																		
0	0	1	1																		
1	1	0	1																		
1	1	1	0																		
6:0	Header Type (HTYPE) — RO. This 7-bit field identifies the header layout of the configuration space, which is a PCI-to-PCI bridge in this case.																				

9.1.9 BNUM—Bus Number Register (PCI-PCI—D30:F0)

Offset Address: 18-1Ah Attribute: R/W, RO
 Default Value: 000000h Size: 24 bits

Bit	Description
23:16	Subordinate Bus Number (SBBN) — R/W. Indicates the highest PCI bus number below the bridge.
15:8	Secondary Bus Number (SCBN) — R/W. Indicates the bus number of PCI.
7:0	Primary Bus Number (PBN) — RO. Hardwired to 00h for legacy software compatibility.

9.1.10 SMLT—Secondary Master Latency Timer Register (PCI-PCI—D30:F0)

Offset Address: 1Bh Attribute: R/W, RO
 Default Value: 00h Size: 8 bits

This timer controls the amount of time the ICH6 PCI-to-PCI bridge will burst data on its secondary interface. The counter starts counting down from the assertion of FRAME#. If the grant is removed, then the expiration of this counter will result in the de-assertion of FRAME#. If the grant has not been removed, then the ICH6 PCI-to-PCI bridge may continue ownership of the bus.

Bit	Description
7:3	Master Latency Timer Count (MLTC) — R/W. This 5-bit field indicates the number of PCI clocks, in 8-clock increments, that the ICH6 remains as master of the bus.
2:0	Reserved

9.1.11 IOBASE_LIMIT—I/O Base and Limit Register (PCI-PCI—D30:F0)

Offset Address: 1C-1Dh Attribute: R/W, RO
 Default Value: 0000h Size: 16 bits

Bit	Description
15:12	I/O Limit Address Limit bits[15:12] — R/W. I/O These base address bits corresponding to address lines 15:12 for 4-KB alignment. Bits 11:0 are assumed to be padded to FFFh.
11:8	I/O Limit Address Capability (IOLC) — RO. This field indicates that the bridge does not support 32-bit I/O addressing.
7:4	I/O Base Address (IOBA) — R/W. These I/O Base address bits corresponding to address lines 15:12 for 4-KB alignment. Bits 11:0 are assumed to be padded to 000h.
3:0	I/O Base Address Capability (IOBC) — RO. This field indicates that the bridge does not support 32-bit I/O addressing.

9.1.12 SECSTS—Secondary Status Register (PCI-PCI—D30:F0)

Offset Address: 1E–1Fh Attribute: R/WC, RO
 Default Value: 0280h Size: 16 bits

Note: For the writable bits, software must write a 1 to clear bits that are set. Writing a 0 to the bit has no effect.

Bit	Description
15	Detected Parity Error (DPE) — R/WC. 0 = Parity error not detected. 1 = Intel® ICH6 PCI bridge detected an address or data parity error on the PCI bus
14	Received System Error (RSE) — R/WC. 0 = SERR# assertion not received 1 = SERR# assertion is received on PCI.
13	Received Master Abort (RMA) — R/WC. 0 = No master abort. 1 = This bit is set whenever the bridge is acting as an initiator on the PCI bus and the cycle is master-aborted. For (G)MCH/ICH6 interface packets that have completion required, this must also cause a target abort to be returned and sets PSTS.STA. (D30:F0:06 bit 11)
12	Received Target Abort (RTA) — R/WC. 0 = No target abort. 1 = This bit is set whenever the bridge is acting as an initiator on PCI and a cycle is target-aborted on PCI. For (G)MCH/ICH6 interface packets that have completion required, this event must also cause a target abort to be returned, and sets PSTS.STA. (D30:F0:06 bit 11).
11	Signaled Target Abort (STA) — R/WC. 0 = No target abort. 1 = This bit is set when the bridge is acting as a target on the PCI Bus and signals a target abort.
10:9	DEVSEL# Timing (DEVT) — RO. 01h = Medium decode timing.
8	Data Parity Error Detected (DPD) — R/WC. 0 = Conditions described below not met. 1 = The ICH6 sets this bit when all of the following three conditions are met: <ul style="list-style-type: none"> • The bridge is the initiator on PCI. • PERR# is detected asserted or a parity error is detected internally • BCTRL.PERE (D30:F0:3E bit 0) is set.
7	Fast Back to Back Capable (FBC) — RO. Hardwired to 1 to indicate that the PCI to PCI target logic is capable of receiving fast back-to-back cycles.
6	Reserved
5	66 MHz Capable (66MHZ_CAP) — RO. Hardwired to 0. This bridge is 33 MHz capable only.
4:0	Reserved

9.1.13 MEMBASE_LIMIT—Memory Base and Limit Register (PCI-PCI—D30:F0)

Offset Address: 20–23h Attribute: R/W, RO
Default Value: 00000000h Size: 32 bits

This register defines the base and limit, aligned to a 1-MB boundary, of the non-prefetchable memory area of the bridge. Accesses that are within the ranges specified in this register will be sent to PCI if CMD.MSE is set. Accesses from PCI that are outside the ranges specified will be accepted by the bridge if CMD.BME is set.

Bit	Description
31-20	Memory Limit (ML) — R/W. These bits are compared with bits 31:20 of the incoming address to determine the upper 1-MB aligned value (exclusive) of the range. The incoming address must be less than this value.
19-16	Reserved
15:4	Memory Base (MB) — R/W. These bits are compared with bits 31:20 of the incoming address to determine the lower 1-MB aligned value (inclusive) of the range. The incoming address must be greater than or equal to this value.
3:0	Reserved

9.1.14 PREF_MEM_BASE_LIMIT—Prefetchable Memory Base and Limit Register (PCI-PCI—D30:F0)

Offset Address: 24–27h Attribute: R/W, RO
Default Value: 00010001h Size: 32-bit

Defines the base and limit, aligned to a 1-MB boundary, of the prefetchable memory area of the bridge. Accesses that are within the ranges specified in this register will be sent to PCI if CMD.MSE is set. Accesses from PCI that are outside the ranges specified will be accepted by the bridge if CMD.BME is set.

Bit	Description
31-20	Prefetchable Memory Limit (PML) — R/W. These bits are compared with bits 31:20 of the incoming address to determine the upper 1-MB aligned value (exclusive) of the range. The incoming address must be less than this value.
19-16	64-bit Indicator (I64L) — RO. This field indicates support for 64-bit addressing.
15:4	Prefetchable Memory Base (PMB) — R/W. These bits are compared with bits 31:20 of the incoming address to determine the lower 1-MB aligned value (inclusive) of the range. The incoming address must be greater than or equal to this value.
3:0	64-bit Indicator (I64B) — RO. This field indicates support for 64-bit addressing.

9.1.15 PMBU32—Prefetchable Memory Base Upper 32 Bits Register (PCI-PCI—D30:F0)

Offset Address: 28–2Bh Attribute: R/W
 Default Value: 00000000h Size: 32 bits

Bit	Description
31:0	Prefetchable Memory Base Upper Portion (PMBU) — R/W. This field provides the upper 32-bits of the prefetchable address base.

9.1.16 PMLU32—Prefetchable Memory Limit Upper 32 Bits Register (PCI-PCI—D30:F0)

Offset Address: 2C–2Fh Attribute: R/W
 Default Value: 00000000h Size: 32 bits

Bit	Description
31:0	Prefetchable Memory Limit Upper Portion (PMLU) — R/W. This field provides the upper 32-bits of the prefetchable address limit.

9.1.17 CAPP—Capability List Pointer Register (PCI-PCI—D30:F0)

Offset Address: 34h Attribute: RO
 Default Value: 50h Size: 8 bits

Bit	Description
7:0	Capabilities Pointer (PTR) — RO. This field indicates that the pointer for the first entry in the capabilities list is at 50h in configuration space.

9.1.18 INTR—Interrupt Information Register (PCI-PCI—D30:F0)

Offset Address: 3C–3Dh Attribute: R/W, RO
 Default Value: 0000h Size: 16 bits

Bit	Description
15:8	Interrupt Pin (IPIN) — RO. The PCI bridge does not assert an interrupt.
7:0	Interrupt Line (ILINE) — R/W. Software written value to indicate which interrupt line (vector) the interrupt is connected to. No hardware action is taken on this register. Since the bridge does not generate an interrupt, BIOS should program this value to FFh as per the PCI bridge specification.

9.1.19 BCTRL—Bridge Control Register (PCI-PCI—D30:F0)

Offset Address: 3E–3Fh Attribute: R/WC, RO
 Default Value: 0000h Size: 16 bits

Bit	Description
15:12	Reserved
11	Discard Timer SERR# Enable (DTE) — R/W. This bit controls the generation of SERR# on the primary interface in response to the DTS bit being set: 0 = Do not generate SERR# on a secondary timer discard 1 = Generate SERR# in response to a secondary timer discard
10	Discard Timer Status (DTS) — R/WC. This bit is set to 1 when the secondary discard timer (see the SDT bit below) expires for a delayed transaction in the hard state.
9	Secondary Discard Timer (SDT) — R/W. This bit sets the maximum number of PCI clock cycles that the Intel® ICH6 waits for an initiator on PCI to repeat a delayed transaction request. The counter starts once the delayed transaction data has been returned by the system and is in a buffer in the ICH6 PCI bridge. If the master has not repeated the transaction at least once before the counter expires, the ICH6 PCI bridge discards the transaction from its queue. 0 = The PCI master timeout value is between 2^{15} and 2^{16} PCI clocks 1 = The PCI master timeout value is between 2^{10} and 2^{11} PCI clocks
8	Primary Discard Timer (PDT) — R/W. This bit is R/W for software compatibility only.
7	Fast Back to Back Enable (FBE) — RO. Hardwired to 0. The PCI logic will not generate fast back-to-back cycles on the PCI bus.
6	Secondary Bus Reset (SBR) — R/W. This bit controls PCIRST# assertion on PCI. 0 = Bridge de-asserts PCIRST# 1 = Bridge asserts PCIRST#. When PCIRST# is asserted, the delayed transaction buffers, posting buffers, and the PCI bus are initialized back to reset conditions. The rest of the part and the configuration registers are not affected. Note: When PCIRST# is asserted by setting this bit, the PCI bus will be in reset. PCI transactions will not be able to complete while this bit is set. When cleared, the bus will exit the reset state and transactions can be completed.
5	Master Abort Mode (MAM) — R/W. This bit controls the ICH6 PCI bridge's behavior when a master abort occurs: Master Abort on (G)MCH/ICH6 Interconnect (DMI): 0 = Bridge asserts TRDY# on PCI. It drives all 1s for reads, and discards data on writes. 1 = Bridge returns a target abort on PCI. Master Abort PCI (non-locked cycles): 0 = Normal completion status will be returned on the (G)MCH/ICH6 interconnect. 1 = Target abort completion status will be returned on the (G)MCH/ICH6 interconnect. NOTE: All locked reads will return a completer abort completion status on the (G)MCH/ICH6 interconnect.
4	VGA 16-Bit Decode (V16D) — R/W. Enables the ICH6 PCI bridge to provide 16-bits decoding of VGA I/O address precluding the decode of VGA alias addresses every 1 KB. This bit requires the VGAE bit in this register be set.

Bit	Description
3	<p>VGA Enable (VGAE) — R/W. When set to a 1, the ICH6 PCI bridge forwards the following transactions to PCI regardless of the value of the I/O base and limit registers. The transactions are qualified by CMD.MSE (D30:F0:04 bit 1) and CMD.IOSE (D30:F0:04 bit 0) being set.</p> <ul style="list-style-type: none"> Memory addresses: 000A0000h-000BFFFFh I/O addresses: 3B0h-3BBh and 3C0h-3DFh. For the I/O addresses, bits [63:16] of the address must be 0, and bits [15:10] of the address are ignored (i.e., aliased). <p>The same holds true from secondary accesses to the primary interface in reverse. That is, when the bit is 0, memory and I/O addresses on the secondary interface between the above ranges will be claimed.</p>
2	<p>ISA Enable (IE) — R/W. This bit only applies to I/O addresses that are enabled by the I/O Base and I/O Limit registers and are in the first 64 KB of PCI I/O space. If this bit is set, the ICH6 PCI bridge will block any forwarding from primary to secondary of I/O transactions addressing the last 768 bytes in each 1-KB block (offsets 100h to 3FFh).</p>
1	<p>SERR# Enable (SEE) — R/W. This bit controls the forwarding of secondary interface SERR# assertions on the primary interface. When set, the PCI bridge will forward SERR# pin.</p> <ul style="list-style-type: none"> SERR# is asserted on the secondary interface. This bit is set. CMD.SEE (D30:F0:04 bit 8) is set.
0	<p>Parity Error Response Enable (PERE) — R/W.</p> <p>0 = Disable 1 = The ICH6 PCI bridge is enabled for parity error reporting based on parity errors on the PCI bus.</p>

9.1.20 SPDH—Secondary PCI Device Hiding Register (PCI-PCI—D30:F0)

Offset Address: 40–41h Attribute: R/W, RO
 Default Value: 00h Size: 16 bits

This register allows software to hide the PCI devices, either plugged into slots or on the motherboard.

Bit	Description
15:8	Reserved
7	Hide Device 7 (HD7) — R/W, RO. Same as bit 0 of this register, except for device 7 (AD[23])
6	Hide Device 6 (HD6) — R/W, RO. Same as bit 0 of this register, except for device 6 (AD[22])
5	Hide Device 5 (HD5) — R/W, RO. Same as bit 0 of this register, except for device 5 (AD[21])
4	Hide Device 4 (HD4) — R/W, RO. Same as bit 0 of this register, except for device 4 (AD[20])
3	Hide Device 3 (HD3) — R/W, RO. Same as bit 0 of this register, except for device 3 (AD[19])
2	Hide Device 2 (HD2) — R/W, RO. Same as bit 0 of this register, except for device 2 (AD[18])
1	Hide Device 1 (HD1) — R/W, RO. Same as bit 0 of this register, except for device 1 (AD[17])
0	<p>Hide Device 0 (HD0) — R/W, RO.</p> <p>0 = The PCI configuration cycles for this slot are not affected. 1 = Intel® ICH6 hides device 0 on the PCI bus. This is done by masking the IDSEL (keeping it low) for configuration cycles to that device. Since the device will not see its IDSEL go active, it will not respond to PCI configuration cycles and the processor will think the device is not present. AD[16] is used as IDSEL for device 0.</p>

9.1.21 PDPR—PCI Decode Policy Register (PCI-PCI—D30:F0)

Offset Address: 42h
Default Value: 00h

Attribute: R/W
Size: 8 bits

Bit	Description
7:1	Reserved
0	Subtractive Decode Policy (SDP) — R/W. 0 = The PCI bridge always forwards memory and I/O cycles that are not claimed by any other device on the backbone (primary interface) to the PCI bus (secondary interface). 1 = The PCI bridge will not claim and forward memory or I/O cycles at all unless the corresponding Space Enable bit is set in the Command register. NOTE: The Boot BIOS Destination Selection strap can force the BIOS accesses to PCI.

9.1.22 DTC—Delayed Transaction Control Register (PCI-PCI—D30:F0)

Offset Address: 44–47h Attribute: R/W, RO
 Default Value: 00000000h Size: 32 bits

Bit	Description
31	<p>Discard Delayed Transactions (DDT) — R/W.</p> <p>0 = Logged delayed transactions are kept. 1 = The ICH6 PCI bridge will discard any delayed transactions it has logged. This includes transactions in the pending queue, and any transactions in the active queue, whether in the hard or soft DT state. The prefetchers will be disabled and return to an idle state.</p> <p>NOTE: If a transaction is running on PCI at the time this bit is set, that transaction will continue until either the PCI master disconnects (by de-asserting FRAME#) or the PCI bridge disconnects (by asserting STOP#). This bit is cleared by the PCI bridge when the delayed transaction queues are empty and have returned to an idle state. Software sets this bit and polls for its completion</p>
30	<p>Block Delayed Transactions (BDT) — R/W.</p> <p>0 = Delayed transactions accepted 1 = The ICH6 PCI bridge will not accept incoming transactions which will result in delayed transactions. It will blindly retry these cycles by asserting STOP#. All postable cycles (memory writes) will still be accepted.</p>
29: 8	Reserved
7: 6	<p>Maximum Delayed Transactions (MDT) — R/W. Controls the maximum number of delayed transactions that the ICH6 PCI bridge will run. Encodings are:</p> <p>00 =) 2 Active, 5 pending 01 =) 2 active, no pending 10 =) 1 active, no pending 11 =) Reserved</p>
5	Reserved
4	<p>Auto Flush After Disconnect Enable (AFADE) — R/W.</p> <p>0 = The PCI bridge will retain any fetched data until required to discard by producer/consumer rules. 1 = The PCI bridge will flush any prefetched data after either the PCI master (by de-asserting FRAME#) or the PCI bridge (by asserting STOP#) disconnects the PCI transfer.</p>
3	<p>Never Prefetch (NP) — R/W.</p> <p>0 = Prefetch enabled 1 = The ICH6 will only fetch a single DW and will not enable prefetching, regardless of the command being an Memory read (MR), Memory read line (MRL), or Memory read multiple (MRM).</p>
2	<p>Memory Read Multiple Prefetch Disable (MRMPD) — R/W.</p> <p>0 = MRM commands will fetch multiple cache lines as defined by the prefetch algorithm. 1 = Memory read multiple (MRM) commands will fetch only up to a single, 64-byte aligned cache line.</p>
1	<p>Memory Read Line Prefetch Disable (MRLPD) — R/W.</p> <p>0 = MRL commands will fetch multiple cache lines as defined by the prefetch algorithm. 1 = Memory read line (MRL) commands will fetch only up to a single, 64-byte aligned cache line.</p>
0	<p>Memory Read Prefetch Disable (MRPD) — R/W.</p> <p>0 = MR commands will fetch up to a 64-byte aligned cache line. 1 = Memory read (MR) commands will fetch only a single DW.</p>

9.1.23 BPS—Bridge Proprietary Status Register (PCI-PCI—D30:F0)

Offset Address: 48–4Bh
 Default Value: 00000000h

Attribute: R/WC, RO
 Size: 32 bits

Bit	Description
31:17	Reserved
16	<p>PERR# Assertion Detected (PAD) — R/WC. This bit is set by hardware whenever the PERR# pin is asserted on the rising edge of PCI clock. This includes cases in which the chipset is the agent driving PERR#. It remains asserted until cleared by software writing a 1 to this location. When enabled by the PERR#-to-SERR# Enable bit (in the Bridge Policy Configuration register), a 1 in this bit can generate an internal SERR# and be a source for the NMI logic.</p> <p>This bit can be used by software to determine the source of a system problem.</p>
15:7	Reserved
6:4	<p>Number of Pending Transactions (NPT) — RO. This read-only indicator tells debug software how many transactions are in the pending queue. Possible values are:</p> <p>000 = No pending transaction 001 = 1 pending transaction 010 = 2 pending transactions 011 = 3 pending transactions 100 = 4 pending transactions 101 = 5 pending transactions 110 - 111 = Reserved</p> <p>NOTE: This field is not valid if DTC.MDT (offset 44h:bits 7:6) is any value other than '00'.</p>
3:2	Reserved
1:0	<p>Number of Active Transactions (NAT) — RO. This read-only indicator tells debug software how many transactions are in the active queue. Possible values are:</p> <p>00 = No active transactions 01 = 1 active transaction 10 = 2 active transactions 11 = Reserved</p>

9.1.24 BPC—Bridge Policy Configuration Register (PCI-PCI—D30:F0)

Offset Address: 4C–4Fh Attribute: R/W, RO
 Default Value: 00000000h Size: 32 bits

Bit	Description
31:7	Reserved
6	PERR#-to-SERR# Enable (PSE) — R/W. When this bit is set, a 1 in the PERR# Assertion status bit (in the Bridge Proprietary Status register) will result in an internal SERR# assertion on the primary side of the bridge (if also enabled by the SERR# Enable bit in the primary Command register). SERR# is a source of NMI.
5	Secondary Discard Timer Testmode (SDTT) — R/W. 0 = The secondary discard timer expiration will be defined in BCTRL.SDT (D30:F0:3E, bit 9) 1 = The secondary discard timer will expire after 128 PCI clocks.
4:3	Reserved
2	Reserved
1	Reserved
0	Received Target Abort SERR# Enable (RTAE) — R/W. When set, the PCI bridge will report SERR# when PSTS.RTA (D30:F0:06 bit 12) or SSTS.RTA (D30:F0:1E bit 12) are set, and CMD.SEE (D30:F0:04 bit 8) is set.

9.1.25 SVCAP—Subsystem Vendor Capability Register (PCI-PCI—D30:F0)

Offset Address: 50–51h Attribute: RO
 Default Value: 000Dh Size: 16 bits

Bit	Description
15:8	Next Capability (NEXT) — RO. Value of 00h indicates this is the last item in the list.
7:0	Capability Identifier (CID) — RO. Value of 0Dh indicates this is a PCI bridge subsystem vendor capability.



9.1.26 SVID—Subsystem Vendor IDs Register (PCI-PCI—D30:F0)

Offset Address: 54–57h Attribute: R/WO
Default Value: 00000000h Size: 32 bits

Bit	Description
31:16	Subsystem Identifier (SID) — R/WO. This field indicates the subsystem as identified by the vendor. This field is write once and is locked down until a bridge reset occurs (not the PCI bus reset).
15:0	Subsystem Vendor Identifier (SVID) — R/WO. This field indicates the manufacturer of the subsystem. This field is write once and is locked down until a bridge reset occurs (not the PCI bus reset).

§



10 LPC Interface Bridge Registers (D31:F0)

The LPC bridge function of the ICH6 resides in PCI Device 31:Function 0. This function contains many other functional units, such as DMA and Interrupt controllers, Timers, Power Management, System Management, GPIO, RTC, and LPC Configuration Registers.

Registers and functions associated with other functional units (EHCI, UHCI, IDE, etc.) are described in their respective sections.

10.1 PCI Configuration Registers (LPC I/F—D31:F0)

Note: Address locations that are not shown should be treated as Reserved.

Table 10-1. LPC Interface PCI Register Address Map (LPC I/F—D31:F0) (Sheet 1 of 2)

Offset	Mnemonic	Register Name	Default	Type
00–01h	VID	Vendor Identification	8086h	RO
02–03h	DID	Device Identification	2641h ICH6-M 2640h ICH6/ICH6R	RO
04–05h	PCICMD	PCI Command	0007h	R/W, RO
06–07h	PCISTS	PCI Status	0200h	R/WC, RO
08h	RID	Revision Identification	See register description.	RO
09h	PI	Programming Interface	00h	RO
0Ah	SCC	Sub Class Code	01h	RO
0Bh	BCC	Base Class Code	06h	RO
0Dh	PLT	Primary Latency Timer	00h	RO
0Eh	HEADTYP	Header Type	80h	RO
2C–2Fh	SS	Sub System Identifiers	00000000h	R/WO
40–43h	PMBASE	ACPI Base Address	00000001h	R/W, RO
44h	ACPI_CNTL	ACPI Control	00h	R/W
48–4Bh	GPIOBASE	GPIO Base Address	00000001h	R/W, RO
4C	GC	GPIO Control	00h	R/W
60–63h	PIRQ[n]_ROUT	PIRQ[A–D] Routing Control	80h	R/W
64h	SIRQ_CNTL	Serial IRQ Control	10h	R/W, RO
68–6Bh	PIRQ[n]_ROUT	PIRQ[E–H] Routing Control	80h	R/W
80h	LPC_I/O_DEC	I/O Decode Ranges	0000h	R/W
82–83h	LPC_EN	LPC I/F Enables	0000h	R/W

Table 10-1. LPC Interface PCI Register Address Map (LPC I/F—D31:F0) (Sheet 2 of 2)

Offset	Mnemonic	Register Name	Default	Type
84–85h	GEN1_DEC	LPC I/F Generic Decode Range 1	0000h	R/W
88–89h	GEN2_DEC	LPC I/F Generic Decode Range 2	0000h	R/W
A0–CFh		Power Management (See Section 10.8.1)		
D0–D3h	FWH_SEL1	Firmware Hub Select 1	00112233h	R/W, RO
D4–D5h	FWH_SEL2	Firmware Hub Select 2	4567h	R/W
D8–D9h	FWH_DEC_EN1	Firmware Hub Decode Enable 1	FFCFh	R/W, RO
DCh	BIOS_CNTL	BIOS Control	00h	R/WLO, R/W
F0–F3h	RCBA	Root Complex Base Address	00000000h	R/W

10.1.1 VID—Vendor Identification Register (LPC I/F—D31:F0)

Offset Address: 00–01h Attribute: RO
 Default Value: 8086h Size: 16-bit
 Lockable: No Power Well: Core

Bit	Description
15:0	Vendor ID — RO. This is a 16-bit value assigned to Intel. Intel VID = 8086h

10.1.2 DID—Device Identification Register (LPC I/F—D31:F0)

Offset Address: 02–03h Attribute: RO
 Default Value: ICH6/ICH6R: 2640h Size: 16-bit
 ICH6-M: 2641h
 Lockable: No Power Well: Core

Bit	Description
15:0	Device ID — RO. This is a 16-bit value assigned to the ICH6 LPC bridge.

10.1.3 PCICMD—PCI COMMAND Register (LPC I/F—D31:F0)

Offset Address:	04–05h	Attribute:	R/W, RO
Default Value:	0007h	Size:	16-bit
Lockable:	No	Power Well:	Core

Bit	Description
15:10	Reserved
9	Fast Back to Back Enable (FBE) — RO. Hardwired to 0.
8	SERR# Enable (SERR_EN) — R/W. The LPC bridge generates SERR# if this bit is set.
7	Wait Cycle Control (WCC) — RO. Hardwired to 0.
6	Parity Error Response Enable (PERE) — R/W. 0 = No action is taken when detecting a parity error. 1 = Enables the ICH6 LPC bridge to respond to parity errors detected on backbone interface.
5	VGA Palette Snoop (VPS) — RO. Hardwired to 0.
4	Memory Write and Invalidate Enable (MWIE) — RO. Hardwired to 0.
3	Special Cycle Enable (SCE) — RO. Hardwired to 0.
2	Bus Master Enable (BME) — RO. Bus Masters cannot be disabled.
1	Memory Space Enable (MSE) — RO. Memory space cannot be disabled on LPC.
0	I/O Space Enable (IOSE) — RO. I/O space cannot be disabled on LPC.

10.1.4 PCISTS—PCI Status Register (LPC I/F—D31:F0)

Offset Address:	06–07h	Attribute:	RO, R/WC
Default Value:	0200h	Size:	16-bit
Lockable:	No	Power Well:	Core

Note: For the writable bits, software must write a 1 to clear bits that are set. Writing a 0 to the bit has no effect.

Bit	Description
15	Detected Parity Error (DPE) — R/WC. Set when the LPC bridge detects a parity error on the internal backbone. Set even if the PCICMD.PERE bit (D31:F0:04, bit 6) is 0 0 = Parity Error Not detected. 1 = Parity Error detected.
14	Signaled System Error (SSE) — R/WC. Set when the LPC bridge signals a system error to the internal SERR# logic.
13	Master Abort Status (RMA) — R/WC. 0 = Unsupported request status not received. 1 = The bridge received a completion with unsupported request status from the backbone.
12	Received Target Abort (RTA) — R/WC. 0 = Completion abort not received. 1 = Completion with completion abort received from the backbone.
11	Signaled Target Abort (STA) — R/WC. 0 = Target abort Not generated on the backbone. 1 = LPC bridge generated a completion packet with target abort status on the backbone.
10:9	DEVSEL# Timing Status (DEV_STS) — RO. 01 = Medium Timing.
8	Data Parity Error Detected (DPED) — R/WC. 0 = All conditions listed below Not met. 1 = Set when all three of the following conditions are met: <ul style="list-style-type: none"> LPC bridge receives a completion packet from the backbone from a previous request, Parity error has been detected (D31:F0:06, bit 15) PCICMD.PERE bit (D31:F0:04, bit 6) is set.
7	Fast Back to Back Capable (FBC): Reserved – bit has no meaning on the internal backbone.
6	Reserved.
5	66 MHz Capable (66MHZ_CAP) — Reserved – bit has no meaning on internal backbone.
4	Capabilities List (CLIST) — RO. No capability list exist on the LPC bridge.
3	Interrupt Status (IS) — RO. The LPC bridge does not generate interrupts.
2:0	Reserved.



10.1.5 RID—Revision Identification Register (LPC I/F—D31:F0)

Offset Address: 08h Attribute: RO
Default Value: See bit description Size: 8 bits

Bit	Description
7:0	Revision ID (RID) — RO. Refer to the <i>Intel® I/O Controller Hub 6 (ICH6) Family Specification Update</i> for the value of the Revision ID Register

10.1.6 PI—Programming Interface Register (LPC I/F—D31:F0)

Offset Address: 09h Attribute: RO
Default Value: 00h Size: 8 bits

Bit	Description
7:0	Programming Interface — RO.

10.1.7 SCC—Sub Class Code Register (LPC I/F—D31:F0)

Offset Address: 0Ah Attribute: RO
Default Value: 01h Size: 8 bits

Bit	Description
7:0	Sub Class Code — RO. 8-bit value that indicates the category of bridge for the LPC bridge. 01h = PCI-to-ISA bridge.

10.1.8 BCC—Base Class Code Register (LPC I/F—D31:F0)

Offset Address: 0Bh Attribute: RO
Default Value: 06h Size: 8 bits

Bit	Description
7:0	Base Class Code — RO. This field is an 8-bit value that indicates the type of device for the LPC bridge. 06h = Bridge device.

10.1.9 PLT—Primary Latency Timer Register (LPC I/F—D31:F0)

Offset Address: 0Dh Attribute: RO
Default Value: 00h Size: 8 bits

Bit	Description
7:3	Master Latency Count (MLC) — Reserved.
2:0	Reserved.

10.1.10 HEADTYP—Header Type Register (LPC I/F—D31:F0)

Offset Address: 0Eh Attribute: RO
Default Value: 80h Size: 8 bits

Bit	Description
7	Multi-Function Device — RO. This bit is 1 to indicate a multi-function device.
6:0	Header Type — RO. This 7-bit field identifies the header layout of the configuration space.

10.1.11 SS—Sub System Identifiers Register (LPC I/F—D31:F0)

Offset Address: 2C–2Fh Attribute: R/WO
Default Value: 00000000h Size: 32 bits

This register is initialized to logic 0 by the assertion of PLTRST#. This register can be written only once after PLTRST# de-assertion.

Bit	Description
31:16	Subsystem ID (SSID) — R/WO. This field is written by BIOS. No hardware action taken on this value.
15:0	Subsystem Vendor ID (SSVID) — R/WO. This field is written by BIOS. No hardware action taken on this value.

10.1.12 PMBASE—ACPI Base Address Register (LPC I/F—D31:F0)

Offset Address:	40–43h	Attribute:	R/W, RO
Default Value:	00000001h	Size:	32 bit
Lockable:	No	Usage:	ACPI, Legacy
		Power Well:	Core

Sets base address for ACPI I/O registers, GPIO registers and TCO I/O registers. These registers can be mapped anywhere in the 64-K I/O space on 128-byte boundaries.

Bit	Description
31:16	Reserved
15:7	Base Address — R/W. This field provides 128 bytes of I/O space for ACPI, GPIO, and TCO logic. This is placed on a 128-byte boundary.
6:1	Reserved
0	Resource Type Indicator (RTE) — RO. Hardwired to 1 to indicate I/O space.

10.1.13 ACPI_CNTL—ACPI Control Register (LPC I/F — D31:F0)

Offset Address:	44h	Attribute:	R/W
Default Value:	00h	Size:	8 bit
Lockable:	No	Usage:	ACPI, Legacy
		Power Well:	Core

Bit	Description																		
7	ACPI Enable (ACPI_EN) — R/W. 0 = Disable. 1 = Decode of the I/O range pointed to by the ACPI base register is enabled, and the ACPI power management function is enabled. Note that the APM power management ranges (B2/B3h) are always enabled and are not affected by this bit.																		
6:3	Reserved																		
2:0	SCI IRQ Select (SCI_IRQ_SEL) — R/W. This field specifies on which IRQ the SCI will internally appear. If not using the APIC, the SCI must be routed to IRQ9–11, and that interrupt is not sharable with the SERIRQ stream, but is shareable with other PCI interrupts. If using the APIC, the SCI can also be mapped to IRQ20–23, and can be shared with other interrupts. <table border="0" style="margin-left: 40px;"> <thead> <tr> <th>Bits</th> <th>SCI Map</th> </tr> </thead> <tbody> <tr> <td>000b</td> <td>IRQ9</td> </tr> <tr> <td>001b</td> <td>IRQ10</td> </tr> <tr> <td>010b</td> <td>IRQ11</td> </tr> <tr> <td>011b</td> <td>Reserved</td> </tr> <tr> <td>100b</td> <td>IRQ20 (Only available if APIC enabled)</td> </tr> <tr> <td>101b</td> <td>IRQ21 (Only available if APIC enabled)</td> </tr> <tr> <td>110b</td> <td>IRQ22 (Only available if APIC enabled)</td> </tr> <tr> <td>111b</td> <td>IRQ23 (Only available if APIC enabled)</td> </tr> </tbody> </table> <p>NOTE: When the TCO interrupt is mapped to APIC interrupts 9, 10 or 11, the signal is in fact active high. When the TCO interrupt is mapped to IRQ 20, 21, 22, or 23, the signal is active low and can be shared with PCI interrupts that may be mapped to those same signals (IRQs).</p>	Bits	SCI Map	000b	IRQ9	001b	IRQ10	010b	IRQ11	011b	Reserved	100b	IRQ20 (Only available if APIC enabled)	101b	IRQ21 (Only available if APIC enabled)	110b	IRQ22 (Only available if APIC enabled)	111b	IRQ23 (Only available if APIC enabled)
Bits	SCI Map																		
000b	IRQ9																		
001b	IRQ10																		
010b	IRQ11																		
011b	Reserved																		
100b	IRQ20 (Only available if APIC enabled)																		
101b	IRQ21 (Only available if APIC enabled)																		
110b	IRQ22 (Only available if APIC enabled)																		
111b	IRQ23 (Only available if APIC enabled)																		

10.1.14 GPIOBASE—GPIO Base Address Register (LPC I/F — D31:F0)

Offset Address: 48–4Bh Attribute: R/W, RO
 Default Value: 00000001h Size: 32 bit

Bit	Description
31:16	Reserved. Always 0.
15:6	Base Address (BA) — R/W. This field provides the 64 bytes of I/O space for GPIO.
5:1	Reserved. Always 0.
0	RO. Hardwired to 1 to indicate I/O space.

10.1.15 GC—GPIO Control Register (LPC I/F — D31:F0)

Offset Address: 4Ch Attribute: R/W
 Default Value: 00h Size: 8 bit

Bit	Description
7:5	Reserved.
4	GPIO Enable (EN) — R/W. This bit enables/disables decode of the I/O range pointed to by the GPIO Base Address register (D31:F0:48h) and enables the GPIO function. 0 = Disable. 1 = Enable.
3:0	Reserved.

10.1.16 PIRQ[n]_ROUT—PIRQ[A,B,C,D] Routing Control Register (LPC I/F—D31:F0)

Offset Address: PIRQA – 60h, PIRQB – 61h, Attribute: R/W
 PIRQC – 62h, PIRQD – 63h
 Default Value: 80h Size: 8 bit
 Lockable: No Power Well: Core

Bit	Description																																				
7	<p>Interrupt Routing Enable (IRQEN) — R/W.</p> <p>0 = The corresponding PIRQ is routed to one of the ISA-compatible interrupts specified in bits[3:0].</p> <p>1 = The PIRQ is not routed to the 8259.</p> <p>NOTE: BIOS must program this bit to 0 during POST for any of the PIRQs that are being used. The value of this bit may subsequently be changed by the OS when setting up for I/O APIC interrupt delivery mode.</p>																																				
6:4	Reserved																																				
3:0	<p>IRQ Routing — R/W. (ISA compatible.)</p> <table border="1"> <thead> <tr> <th>Value</th> <th>IRQ</th> <th>Value</th> <th>IRQ</th> </tr> </thead> <tbody> <tr> <td>0000b</td> <td>Reserved</td> <td>1000b</td> <td>Reserved</td> </tr> <tr> <td>0001b</td> <td>Reserved</td> <td>1001b</td> <td>IRQ9</td> </tr> <tr> <td>0010b</td> <td>Reserved</td> <td>1010b</td> <td>IRQ10</td> </tr> <tr> <td>0011b</td> <td>IRQ3</td> <td>1011b</td> <td>IRQ11</td> </tr> <tr> <td>0100b</td> <td>IRQ4</td> <td>1100b</td> <td>IRQ12</td> </tr> <tr> <td>0101b</td> <td>IRQ5</td> <td>1101b</td> <td>Reserved</td> </tr> <tr> <td>0110b</td> <td>IRQ6</td> <td>1110b</td> <td>IRQ14</td> </tr> <tr> <td>0111b</td> <td>IRQ7</td> <td>1111b</td> <td>IRQ15</td> </tr> </tbody> </table>	Value	IRQ	Value	IRQ	0000b	Reserved	1000b	Reserved	0001b	Reserved	1001b	IRQ9	0010b	Reserved	1010b	IRQ10	0011b	IRQ3	1011b	IRQ11	0100b	IRQ4	1100b	IRQ12	0101b	IRQ5	1101b	Reserved	0110b	IRQ6	1110b	IRQ14	0111b	IRQ7	1111b	IRQ15
Value	IRQ	Value	IRQ																																		
0000b	Reserved	1000b	Reserved																																		
0001b	Reserved	1001b	IRQ9																																		
0010b	Reserved	1010b	IRQ10																																		
0011b	IRQ3	1011b	IRQ11																																		
0100b	IRQ4	1100b	IRQ12																																		
0101b	IRQ5	1101b	Reserved																																		
0110b	IRQ6	1110b	IRQ14																																		
0111b	IRQ7	1111b	IRQ15																																		

10.1.17 SIRQ_CNTL—Serial IRQ Control Register (LPC I/F—D31:F0)

Offset Address:	64h	Attribute:	R/W, RO
Default Value:	10h	Size:	8 bit
Lockable:	No	Power Well:	Core

Bit	Description
7	<p>Serial IRQ Enable (SIRQEN) — R/W.</p> <p>0 = The buffer is input only and internally SERIRQ will be a 1. 1 = Serial IRQs will be recognized. The SERIRQ pin will be configured as SERIRQ.</p>
6	<p>Serial IRQ Mode Select (SIRQMD) — R/W.</p> <p>0 = The serial IRQ machine will be in quiet mode. 1 = The serial IRQ machine will be in continuous mode.</p> <p>NOTE: For systems using Quiet Mode, this bit should be set to 1 (Continuous Mode) for at least one frame after coming out of reset before switching back to Quiet Mode. Failure to do so will result in the ICH6 not recognizing SERIRQ interrupts.</p>
5:2	<p>Serial IRQ Frame Size (SIRQSZ) — RO. This field is fixed to indicate the size of the SERIRQ frame as 21 frames.</p>
1:0	<p>Start Frame Pulse Width (SFPW) — R/W. This is the number of PCI clocks that the SERIRQ pin will be driven low by the serial IRQ machine to signal a start frame. In continuous mode, the ICH6 will drive the start frame for the number of clocks specified. In quiet mode, the ICH6 will drive the start frame for the number of clocks specified minus one, as the first clock was driven by the peripheral.</p> <p>00 = 4 clocks 01 = 6 clocks 10 = 8 clocks 11 = Reserved</p>

10.1.18 PIRQ[n]_ROUT—PIRQ[E,F,G,H] Routing Control Register (LPC I/F—D31:F0)

Offset Address: PIRQE – 68h, PIRQF – 69h, Attribute: R/W
 PIRQG – 6Ah, PIRQH – 6Bh
 Default Value: 80h Size: 8 bit
 Lockable: No Power Well: Core

Bit	Description																																				
7	<p>Interrupt Routing Enable (IRQEN) — R/W.</p> <p>0 = The corresponding PIRQ is routed to one of the ISA-compatible interrupts specified in bits[3:0]. 1 = The PIRQ is not routed to the 8259.</p> <p>NOTE: BIOS must program this bit to 0 during POST for any of the PIRQs that are being used. The value of this bit may subsequently be changed by the OS when setting up for I/O APIC interrupt delivery mode.</p>																																				
6:4	Reserved																																				
3:0	<p>IRQ Routing — R/W. (ISA compatible.)</p> <table border="1"> <thead> <tr> <th>Value</th> <th>IRQ</th> <th>Value</th> <th>IRQ</th> </tr> </thead> <tbody> <tr> <td>0000b</td> <td>Reserved</td> <td>1000b</td> <td>Reserved</td> </tr> <tr> <td>0001b</td> <td>Reserved</td> <td>1001b</td> <td>IRQ9</td> </tr> <tr> <td>0010b</td> <td>Reserved</td> <td>1010b</td> <td>IRQ10</td> </tr> <tr> <td>0011b</td> <td>IRQ3</td> <td>1011b</td> <td>IRQ11</td> </tr> <tr> <td>0100b</td> <td>IRQ4</td> <td>1100b</td> <td>IRQ12</td> </tr> <tr> <td>0101b</td> <td>IRQ5</td> <td>1101b</td> <td>Reserved</td> </tr> <tr> <td>0110b</td> <td>IRQ6</td> <td>1110b</td> <td>IRQ14</td> </tr> <tr> <td>0111b</td> <td>IRQ7</td> <td>1111b</td> <td>IRQ15</td> </tr> </tbody> </table>	Value	IRQ	Value	IRQ	0000b	Reserved	1000b	Reserved	0001b	Reserved	1001b	IRQ9	0010b	Reserved	1010b	IRQ10	0011b	IRQ3	1011b	IRQ11	0100b	IRQ4	1100b	IRQ12	0101b	IRQ5	1101b	Reserved	0110b	IRQ6	1110b	IRQ14	0111b	IRQ7	1111b	IRQ15
Value	IRQ	Value	IRQ																																		
0000b	Reserved	1000b	Reserved																																		
0001b	Reserved	1001b	IRQ9																																		
0010b	Reserved	1010b	IRQ10																																		
0011b	IRQ3	1011b	IRQ11																																		
0100b	IRQ4	1100b	IRQ12																																		
0101b	IRQ5	1101b	Reserved																																		
0110b	IRQ6	1110b	IRQ14																																		
0111b	IRQ7	1111b	IRQ15																																		

10.1.19 LPC_I/O_DEC—I/O Decode Ranges Register (LPC I/F—D31:F0)

Offset Address: 80h Attribute: R/W
Default Value: 0000h Size: 16 bit

Bit	Description
15:13	Reserved
12	FDD Decode Range — R/W. This bit determines which range to decode for the FDD Port 0 = 3F0h – 3F5h, 3F7h (Primary) 1 = 370h – 375h, 377h (Secondary)
11:10	Reserved
9:8	LPT Decode Range — R/W. This field determines which range to decode for the LPT Port. 00 = 378h – 37Fh and 778h – 77Fh 01 = 278h – 27Fh (port 279h is read only) and 678h – 67Fh 10 = 3BCh – 3BEh and 7BCh – 7BEh 11 = Reserved
7	Reserved
6:4	COMB Decode Range — R/W. This field determines which range to decode for the COMB Port. 000 = 3F8h – 3FFh (COM1) 001 = 2F8h – 2FFh (COM2) 010 = 220h – 227h 011 = 228h – 22Fh 100 = 238h – 23Fh 101 = 2E8h – 2EFh (COM4) 110 = 338h – 33Fh 111 = 3E8h – 3EFh (COM3)
3	Reserved
2:0	COMA Decode Range — R/W. This field determines which range to decode for the COMA Port. 000 = 3F8h – 3FFh (COM1) 001 = 2F8h – 2FFh (COM2) 010 = 220h – 227h 011 = 228h – 22Fh 100 = 238h – 23Fh 101 = 2E8h – 2EFh (COM4) 110 = 338h – 33Fh 111 = 3E8h – 3EFh (COM3)

10.1.20 LPC_EN—LPC I/F Enables Register (LPC I/F—D31:F0)

Offset Address:	82h – 83h	Attribute:	R/W
Default Value:	0000h	Size:	16 bit
		Power Well:	Core

Bit	Description
15:14	Reserved
13	CNF2_LPC_EN — R/W. Microcontroller Enable # 2. 0 = Disable. 1 = Enables the decoding of the I/O locations 4Eh and 4Fh to the LPC interface. This range is used for a microcontroller.
12	CNF1_LPC_EN — R/W. Super I/O Enable. 0 = Disable. 1 = Enables the decoding of the I/O locations 2Eh and 2Fh to the LPC interface. This range is used for Super I/O devices.
11	MC_LPC_EN — R/W. Microcontroller Enable # 1. 0 = Disable. 1 = Enables the decoding of the I/O locations 62h and 66h to the LPC interface. This range is used for a microcontroller.
10	KBC_LPC_EN — R/W. Keyboard Enable. 0 = Disable. 1 = Enables the decoding of the I/O locations 60h and 64h to the LPC interface. This range is used for a microcontroller.
9	GAMEH_LPC_EN — R/W. High Gameport Enable 0 = Disable. 1 = Enables the decoding of the I/O locations 208h to 20Fh to the LPC interface. This range is used for a gameport.
8	GAMEL_LPC_EN — R/W. Low Gameport Enable 0 = Disable. 1 = Enables the decoding of the I/O locations 200h to 207h to the LPC interface. This range is used for a gameport.
7:4	Reserved
3	FDD_LPC_EN — R/W. Floppy Drive Enable 0 = Disable. 1 = Enables the decoding of the FDD range to the LPC interface. This range is selected in the LPC_FDD/LPT Decode Range Register (D31:F0:80h, bit 12).
2	LPT_LPC_EN — R/W. Parallel Port Enable 0 = Disable. 1 = Enables the decoding of the LPTrange to the LPC interface. This range is selected in the LPC_FDD/LPT Decode Range Register (D31:F0:80h, bit 9:8).
1	COMB_LPC_EN — R/W. Com Port B Enable 0 = Disable. 1 = Enables the decoding of the COMB range to the LPC interface. This range is selected in the LPC_COM Decode Range Register (D31:F0:80h, bits 6:4).
0	COMA_LPC_EN — R/W. Com Port A Enable 0 = Disable. 1 = Enables the decoding of the COMA range to the LPC interface. This range is selected in the LPC_COM Decode Range Register (D31:F0:80h, bits 3:2).

10.1.21 GEN1_DEC—LPC I/F Generic Decode Range 1 Register (LPC I/F—D31:F0)

Offset Address: 84h – 85h Attribute: R/W
 Default Value: 0000h Size: 16 bit
 Power Well: Core

Bit	Description
15:7	Generic I/O Decode Range 1 Base Address (GEN1_BASE) — R/W. This address is aligned on a 128-byte boundary, and must have address lines 31:16 as 0. NOTE: This generic decode is for I/O addresses only, not memory addresses. The size of this range is 128 bytes.
6:1	Reserved
0	Generic Decode Range 1 Enable (GEN1_EN) — R/W. 0 = Disable. 1 = Enable the GEN1 I/O range to be forwarded to the LPC I/F

10.1.22 GEN2_DEC—LPC I/F Generic Decode Range 2 Register (LPC I/F—D31:F0)

Offset Address: 88h – 89h Attribute: R/W
 Default Value: 0000h Size: 16 bit
 Power Well: Core

Bit	Description
15:4	Generic I/O Decode Range 2 Base Address (GEN2_BASE) — R/W. This address is aligned on a 16-byte, 32-byte, or 64-byte boundary, and must have address lines 31:16 as 0. NOTES: 1. This generic decode is for I/O addresses only, not memory addresses. The size of this range is 16, 32, or 64 bytes. 2. Size of decode range is determined by D31:F0:ADh:bits 5:4.
3:1	Reserved. Read as 0.
0	Generic I/O Decode Range 2 Enable (GEN2_EN) — R/W. 0 = Disable. 1 = Accesses to the GEN2 I/O range will be forwarded to the LPC I/F

10.1.23 FWH_SEL1—Firmware Hub Select 1 Register (LPC I/F—D31:F0)

Offset Address: D0h–D3h Attribute: R/W, RO
 Default Value: 00112233h Size: 32 bits

Bit	Description
31:28	FWH_F8_IDSEL — RO. IDSEL for two 512-KB Firmware Hub memory ranges and one 128-KB memory range. This field is fixed at 0000. The IDSEL programmed in this field addresses the following memory ranges: FFF8 0000h – FFFF FFFFh FFB8 0000h – FFBF FFFFh 000E 0000h – 000F FFFFh
27:24	FWH_F0_IDSEL — R/W. IDSEL for two 512-KB Firmware Hub memory ranges. The IDSEL programmed in this field addresses the following memory ranges: FFF0 0000h – FFF7 FFFFh FFB0 0000h – FFB7 FFFFh
23:20	FWH_E8_IDSEL — R/W. IDSEL for two 512-KB Firmware Hub memory ranges. The IDSEL programmed in this field addresses the following memory ranges: FFE8 0000h – FFEF FFFFh FFA8 0000h – FFAF FFFFh
19:16	FWH_E0_IDSEL — R/W. IDSEL for two 512-KB Firmware Hub memory ranges. The IDSEL programmed in this field addresses the following memory ranges: FFE0 0000h – FFE7 FFFFh FFA0 0000h – FFA7 FFFFh
15:12	FWH_D8_IDSEL — R/W. IDSEL for two 512-KB Firmware Hub memory ranges. The IDSEL programmed in this field addresses the following memory ranges: FFD8 0000h – FFD7 FFFFh FF98 0000h – FF97 FFFFh
11:8	FWH_D0_IDSEL — R/W. IDSEL for two 512-KB Firmware Hub memory ranges. The IDSEL programmed in this field addresses the following memory ranges: FFD0 0000h – FFD7 FFFFh FF90 0000h – FF97 FFFFh
7:4	FWH_C8_IDSEL — R/W. IDSEL for two 512-KB Firmware Hub memory ranges. The IDSEL programmed in this field addresses the following memory ranges: FFC8 0000h – FFC7 FFFFh FF88 0000h – FF87 FFFFh
3:0	FWH_C0_IDSEL — R/W. IDSEL for two 512-KB Firmware Hub memory ranges. The IDSEL programmed in this field addresses the following memory ranges: FFC0 0000h – FFC7 FFFFh FF80 0000h – FF87 FFFFh

10.1.24 FWH_SEL2—Firmware Hub Select 2 Register (LPC I/F—D31:F0)

Offset Address: D4h–D5h Attribute: R/W
 Default Value: 4567h Size: 16 bits

Bit	Description
15:12	FWH_70_IDSEL — R/W. IDSEL for two, 1-M Firmware Hub memory ranges. The IDSEL programmed in this field addresses the following memory ranges: FF70 0000h – FF7F FFFFh FF30 0000h – FF3F FFFFh
11:8	FWH_60_IDSEL — R/W. IDSEL for two, 1-M Firmware Hub memory ranges. The IDSEL programmed in this field addresses the following memory ranges: FF60 0000h – FF6F FFFFh FF20 0000h – FF2F FFFFh
7:4	FWH_50_IDSEL — R/W. IDSEL for two, 1-M Firmware Hub memory ranges. The IDSEL programmed in this field addresses the following memory ranges: FF50 0000h – FF5F FFFFh FF10 0000h – FF1F FFFFh
3:0	FWH_40_IDSEL — R/W. IDSEL for two, 1-M Firmware Hub memory ranges. The IDSEL programmed in this field addresses the following memory ranges: FF40 0000h – FF4F FFFFh FF00 0000h – FF0F FFFFh

10.1.25 FWH_DEC_EN1—Firmware Hub Decode Enable Register (LPC I/F—D31:F0)

Offset Address: D8h–D9h
 Default Value: FFCFh

Attribute: R/W, RO
 Size: 16 bits

Bit	Description
15	<p>FWH_F8_EN — RO. This bit enables decoding two 512-KB Firmware Hub memory ranges, and one 128-KB memory range.</p> <p>0 = Disable 1 = Enable the following ranges for the Firmware Hub FFF80000h – FFFFFFFFh FFB80000h – FFBFFFFFFh</p>
14	<p>FWH_F0_EN — R/W. This bit enables decoding two 512-KB Firmware Hub memory ranges.</p> <p>0 = Disable. 1 = Enable the following ranges for the Firmware Hub: FFF00000h – FFF7FFFFh FFB00000h – FFB7FFFFh</p>
13	<p>FWH_E8_EN — R/W. This bit enables decoding two 512-KB Firmware Hub memory ranges.</p> <p>0 = Disable. 1 = Enable the following ranges for the Firmware Hub: FFE80000h – FFEFFFFFFh FFA80000h – FFAFFFFFFh</p>
12	<p>FWH_E0_EN — R/W. This bit enables decoding two 512-KB Firmware Hub memory ranges.</p> <p>0 = Disable. 1 = Enable the following ranges for the Firmware Hub: FFE00000h – FFE7FFFFh FFA00000h – FFA7FFFFh</p>
11	<p>FWH_D8_EN — R/W. This bit enables decoding two 512-KB Firmware Hub memory ranges.</p> <p>0 = Disable. 1 = Enable the following ranges for the Firmware Hub FFD80000h – FFDFFFFFFh FF980000h – FF9FFFFFFh</p>
10	<p>FWH_D0_EN — R/W. This bit enables decoding two 512-KB Firmware Hub memory ranges.</p> <p>0 = Disable. 1 = Enable the following ranges for the Firmware Hub FFD00000h – FFD7FFFFh FF900000h – FF97FFFFh</p>
9	<p>FWH_C8_EN — R/W. This bit enables decoding two 512-KB Firmware Hub memory ranges.</p> <p>0 = Disable. 1 = Enable the following ranges for the Firmware Hub FFC80000h – FFCFFFFFFh FF880000h – FF8FFFFFFh</p>
8	<p>FWH_C0_EN — R/W. This bit enables decoding two 512-KB Firmware Hub memory ranges.</p> <p>0 = Disable. 1 = Enable the following ranges for the Firmware Hub FFC00000h – FFC7FFFFh FF800000h – FF87FFFFh</p>
7	<p>FWH_Legacy_F_EN — R/W. This enables the decoding of the legacy 128-K range at F0000h – FFFFFFFh.</p> <p>0 = Disable. 1 = Enable the following legacy ranges for the Firmware Hub F0000h – FFFFFFFh</p>

Bit	Description
6	FWH_Legacy_E_EN — R/W. This bit enables the decoding of the legacy 128-K range at E0000h – EFFFFh. 0 = Disable. 1 = Enable the following legacy ranges for the Firmware Hub E0000h – EFFFFh
5:4	Reserved
3	FWH_70_EN — R/W. This bit enables decoding two 1-M Firmware Hub memory ranges. 0 = Disable. 1 = Enable the following ranges for the Firmware Hub FF70 0000h – FF7F FFFFh FF30 0000h – FF3F FFFFh
2	FWH_60_EN — R/W. This bit enables decoding two 1-M Firmware Hub memory ranges. 0 = Disable. 1 = Enable the following ranges for the Firmware Hub FF60 0000h – FF6F FFFFh FF20 0000h – FF2F FFFFh
1	FWH_50_EN — R/W. This bit enables decoding two 1-M Firmware Hub memory ranges. 0 = Disable. 1 = Enable the following ranges for the Firmware Hub FF50 0000h – FF5F FFFFh FF10 0000h – FF1F FFFFh
0	FWH_40_EN — R/W. This bit enables decoding two 1-M Firmware Hub memory ranges. 0 = Disable. 1 = Enable the following ranges for the Firmware Hub FF40 0000h – FF4F FFFFh FF00 0000h – FF0F FFFFh

10.1.26 BIOS_CNTL—BIOS Control Register (LPC I/F—D31:F0)

Offset Address:	DCh	Attribute:	R/WLO, R/W
Default Value:	00h	Size:	8 bit
Lockable:	No	Power Well:	Core

Bit	Description
7:2	Reserved
1	BIOS Lock Enable (BLE) — R/WLO. 0 = Setting the BIOSWE will not cause SMIs. 1 = Enables setting the BIOSWE bit to cause SMIs. Once set, this bit can only be cleared by a PLTRST#
0	BIOS Write Enable (BIOSWE) — R/W. 0 = Only read cycles result in Firmware Hub I/F cycles. 1 = Access to the BIOS space is enabled for both read and write cycles. When this bit is written from a 0 to a 1 and BIOS Lock Enable (BLE) is also set, an SMI# is generated. This ensures that only SMI code can update BIOS.



10.1.27 RCBA—Root Complex Base Address Register (LPC I/F—D31:F0)

Offset Address: F0h Attribute: R/W
 Default Value: 00000000h Size: 32 bit

Bit	Description
31:14	Base Address (BA) — R/W. This field provides the base address for the root complex register block decode range. This address is aligned on a 16-KB boundary.
13:1	Reserved
0	Enable (EN) — R/W. When set, this bit enables the range specified in BA to be claimed as the Root Complex Register Block.

10.2 DMA I/O Registers (LPC I/F—D31:F0)

Table 10-2. DMA Registers (Sheet 1 of 2)

Port	Alias	Register Name	Default	Type
00h	10h	Channel 0 DMA Base & Current Address	Undefined	R/W
01h	11h	Channel 0 DMA Base & Current Count	Undefined	R/W
02h	12h	Channel 1 DMA Base & Current Address	Undefined	R/W
03h	13h	Channel 1 DMA Base & Current Count	Undefined	R/W
04h	14h	Channel 2 DMA Base & Current Address	Undefined	R/W
05h	15h	Channel 2 DMA Base & Current Count	Undefined	R/W
06h	16h	Channel 3 DMA Base & Current Address	Undefined	R/W
07h	17h	Channel 3 DMA Base & Current Count	Undefined	R/W
08h	18h	Channel 0–3 DMA Command	Undefined	WO
		Channel 0–3 DMA Status	Undefined	RO
0Ah	1Ah	Channel 0–3 DMA Write Single Mask	000001XXb	WO
0Bh	1Bh	Channel 0–3 DMA Channel Mode	000000XXb	WO
0Ch	1Ch	Channel 0–3 DMA Clear Byte Pointer	Undefined	WO
0Dh	1Dh	Channel 0–3 DMA Master Clear	Undefined	WO
0Eh	1Eh	Channel 0–3 DMA Clear Mask	Undefined	WO
0Fh	1Fh	Channel 0–3 DMA Write All Mask	0Fh	R/W
80h	90h	Reserved Page	Undefined	R/W
81h	91h	Channel 2 DMA Memory Low Page	Undefined	R/W
82h	—	Channel 3 DMA Memory Low Page	Undefined	R/W
83h	93h	Channel 1 DMA Memory Low Page	Undefined	R/W
84h–86h	94h–96h	Reserved Pages	Undefined	R/W
87h	97h	Channel 0 DMA Memory Low Page	Undefined	R/W
88h	98h	Reserved Page	Undefined	R/W

Table 10-2. DMA Registers (Sheet 2 of 2)

Port	Alias	Register Name	Default	Type
89h	99h	Channel 6 DMA Memory Low Page	Undefined	R/W
8Ah	9Ah	Channel 7 DMA Memory Low Page	Undefined	R/W
8Bh	9Bh	Channel 5 DMA Memory Low Page	Undefined	R/W
8Ch–8Eh	9Ch–9Eh	Reserved Page	Undefined	R/W
8Fh	9Fh	Refresh Low Page	Undefined	R/W
C0h	C1h	Channel 4 DMA Base & Current Address	Undefined	R/W
C2h	C3h	Channel 4 DMA Base & Current Count	Undefined	R/W
C4h	C5h	Channel 5 DMA Base & Current Address	Undefined	R/W
C6h	C7h	Channel 5 DMA Base & Current Count	Undefined	R/W
C8h	C9h	Channel 6 DMA Base & Current Address	Undefined	R/W
CAh	CBh	Channel 6 DMA Base & Current Count	Undefined	R/W
CCh	CDh	Channel 7 DMA Base & Current Address	Undefined	R/W
CEh	CFh	Channel 7 DMA Base & Current Count	Undefined	R/W
D0h	D1h	Channel 4–7 DMA Command	Undefined	WO
		Channel 4–7 DMA Status	Undefined	RO
D4h	D5h	Channel 4–7 DMA Write Single Mask	000001XXb	WO
D6h	D7h	Channel 4–7 DMA Channel Mode	000000XXb	WO
D8h	D9h	Channel 4–7 DMA Clear Byte Pointer	Undefined	WO
DAh	DBh	Channel 4–7 DMA Master Clear	Undefined	WO
DCh	DDh	Channel 4–7 DMA Clear Mask	Undefined	WO
DEh	DFh	Channel 4–7 DMA Write All Mask	0Fh	R/W

10.2.1 DMABASE_CA—DMA Base and Current Address Registers (LPC I/F—D31:F0)

I/O Address:	Ch. #0 = 00h; Ch. #1 = 02h Ch. #2 = 04h; Ch. #3 = 06h Ch. #5 = C4h Ch. #6 = C8h Ch. #7 = CCh;	Attribute:	R/W
		Size:	16 bit (per channel), but accessed in two 8-bit quantities
Default Value:	Undef		
Lockable:	No	Power Well:	Core

Bit	Description
15:0	<p>Base and Current Address — R/W. This register determines the address for the transfers to be performed. The address specified points to two separate registers. On writes, the value is stored in the <i>Base Address</i> register and copied to the <i>Current Address</i> register. On reads, the value is returned from the <i>Current Address</i> register.</p> <p>The address increments/decrements in the Current Address register after each transfer, depending on the mode of the transfer. If the channel is in auto-initialize mode, the Current Address register will be reloaded from the Base Address register after a terminal count is generated.</p> <p>For transfers to/from a 16-bit slave (channel's 5-7), the address is shifted left one bit location. Bit 15 will be shifted into Bit 16.</p> <p>The register is accessed in 8 bit quantities. The byte is pointed to by the current byte pointer flip/flop. Before accessing an address register, the byte pointer flip/flop should be cleared to ensure that the low byte is accessed first</p>

10.2.2 DMABASE_CC—DMA Base and Current Count Registers (LPC I/F—D31:F0)

I/O Address:	Ch. #0 = 01h; Ch. #1 = 03h Ch. #2 = 05h; Ch. #3 = 07h Ch. #5 = C6h; Ch. #6 = CAh Ch. #7 = CEh;	Attribute:	R/W
		Size:	16-bit (per channel), but accessed in two 8-bit quantities
Default Value:	Undefined		
Lockable:	No	Power Well:	Core

Bit	Description
15:0	<p>Base and Current Count — R/W. This register determines the number of transfers to be performed. The address specified points to two separate registers. On writes, the value is stored in the <i>Base Count</i> register and copied to the <i>Current Count</i> register. On reads, the value is returned from the <i>Current Count</i> register.</p> <p>The actual number of transfers is one more than the number programmed in the Base Count Register (i.e., programming a count of 4h results in 5 transfers). The count is decrements in the Current Count register after each transfer. When the value in the register rolls from 0 to FFFFh, a terminal count is generated. If the channel is in auto-initialize mode, the Current Count register will be reloaded from the Base Count register after a terminal count is generated.</p> <p>For transfers to/from an 8-bit slave (channels 0–3), the count register indicates the number of bytes to be transferred. For transfers to/from a 16-bit slave (channels 5–7), the count register indicates the number of words to be transferred.</p> <p>The register is accessed in 8 bit quantities. The byte is pointed to by the current byte pointer flip/flop. Before accessing a count register, the byte pointer flip/flop should be cleared to ensure that the low byte is accessed first.</p>

10.2.3 DMAMEM_LP—DMA Memory Low Page Registers (LPC I/F—D31:F0)

I/O Address: Ch. #0 = 87h; Ch. #1 = 83h
 Ch. #2 = 81h; Ch. #3 = 82h
 Ch. #5 = 8Bh; Ch. #6 = 89h
 Ch. #7 = 8Ah;
 Default Value: Undefined
 Lockable: No

Attribute: R/W
 Size: 8-bit
 Power Well: Core

Bit	Description
7:0	DMA Low Page (ISA Address bits [23:16]) — R/W. This register works in conjunction with the DMA controller's Current Address Register to define the complete 24-bit address for the DMA channel. This register remains static throughout the DMA transfer. Bit 16 of this register is ignored when in 16 bit I/O count by words mode as it is replaced by the bit 15 shifted out from the current address register.

10.2.4 DMACMD—DMA Command Register (LPC I/F—D31:F0)

I/O Address: Ch. #0–3 = 08h;
 Ch. #4–7 = D0h
 Default Value: Undefined
 Lockable: No

Attribute: WO
 Size: 8-bit
 Power Well: Core

Bit	Description
7:5	Reserved. Must be 0.
4	DMA Group Arbitration Priority — WO. Each channel group is individually assigned either fixed or rotating arbitration priority. At part reset, each group is initialized in fixed priority. 0 = Fixed priority to the channel group 1 = Rotating priority to the group.
3	Reserved. Must be 0.
2	DMA Channel Group Enable — WO. Both channel groups are enabled following part reset. 0 = Enable the DMA channel group. 1 = Disable. Disabling channel group 4–7 also disables channel group 0–3, which is cascaded through channel 4.
1:0	Reserved. Must be 0.

10.2.5 DMASTA—DMA Status Register (LPC I/F—D31:F0)

I/O Address:	Ch. #0–3 = 08h; Ch. #4–7 = D0h	Attribute:	RO
Default Value:	Undefined	Size:	8-bit
Lockable:	No	Power Well:	Core

Bit	Description
7:4	<p>Channel Request Status — RO. When a valid DMA request is pending for a channel, the corresponding bit is set to 1. When a DMA request is not pending for a particular channel, the corresponding bit is set to 0. The source of the DREQ may be hardware or a software request. Note that channel 4 is the cascade channel, so the request status of channel 4 is a logical OR of the request status for channels 0 through 3.</p> <p>4 = Channel 0 5 = Channel 1 (5) 6 = Channel 2 (6) 7 = Channel 3 (7)</p>
3:0	<p>Channel Terminal Count Status — RO. When a channel reaches terminal count (TC), its status bit is set to 1. If TC has not been reached, the status bit is set to 0. Channel 4 is programmed for cascade, so the TC bit response for channel 4 is irrelevant:</p> <p>0 = Channel 0 1 = Channel 1 (5) 2 = Channel 2 (6) 3 = Channel 3 (7)</p>

10.2.6 DMA_WRSMSK—DMA Write Single Mask Register (LPC I/F—D31:F0)

I/O Address:	Ch. #0–3 = 0Ah; Ch. #4–7 = D4h	Attribute:	WO
Default Value:	0000 01xx	Size:	8-bit
Lockable:	No	Power Well:	Core

Bit	Description
7:3	Reserved. Must be 0.
2	<p>Channel Mask Select — WO.</p> <p>0 = Enable DREQ for the selected channel. The channel is selected through bits [1:0]. Therefore, only one channel can be masked / unmasked at a time. 1 = Disable DREQ for the selected channel.</p>
1:0	<p>DMA Channel Select — WO. These bits select the DMA Channel Mode Register to program.</p> <p>00 = Channel 0 (4) 01 = Channel 1 (5) 10 = Channel 2 (6) 11 = Channel 3 (7)</p>

10.2.7 DMACH_MODE—DMA Channel Mode Register (LPC I/F—D31:F0)

I/O Address:	Ch. #0–3 = 0Bh; Ch. #4–7 = D6h	Attribute:	WO
Default Value:	0000 00xx	Size:	8-bit
Lockable:	No	Power Well:	Core

Bit	Description
7:6	DMA Transfer Mode — WO. Each DMA channel can be programmed in one of four different modes: 00 = Demand mode 01 = Single mode 10 = Reserved 11 = Cascade mode
5	Address Increment/Decrement Select — WO. This bit controls address increment/decrement during DMA transfers. 0 = Address increment. (default after part reset or Master Clear) 1 = Address decrement.
4	Autoinitialize Enable — WO. 0 = Autoinitialize feature is disabled and DMA transfers terminate on a terminal count. A part reset or Master Clear disables autoinitialization. 1 = DMA restores the Base Address and Count registers to the current registers following a terminal count (TC).
3:2	DMA Transfer Type — WO. These bits represent the direction of the DMA transfer. When the channel is programmed for cascade mode, (bits[7:6] = 11) the transfer type is irrelevant. 00 = Verify – No I/O or memory strobes generated 01 = Write – Data transferred from the I/O devices to memory 10 = Read – Data transferred from memory to the I/O device 11 = Illegal
1:0	DMA Channel Select — WO. These bits select the DMA Channel Mode Register that will be written by bits [7:2]. 00 = Channel 0 (4) 01 = Channel 1 (5) 10 = Channel 2 (6) 11 = Channel 3 (7)

10.2.8 DMA Clear Byte Pointer Register (LPC I/F—D31:F0)

I/O Address:	Ch. #0–3 = 0Ch; Ch. #4–7 = D8h	Attribute:	WO
Default Value:	xxxx xxxx	Size:	8-bit
Lockable:	No	Power Well:	Core

Bit	Description
7:0	Clear Byte Pointer — WO. No specific pattern. Command enabled with a write to the I/O port address. Writing to this register initializes the byte pointer flip/flop to a known state. It clears the internal latch used to address the upper or lower byte of the 16-bit Address and Word Count Registers. The latch is also cleared by part reset and by the Master Clear command. This command precedes the first access to a 16-bit DMA controller register. The first access to a 16-bit register will then access the significant byte, and the second access automatically accesses the most significant byte.

10.2.9 DMA Master Clear Register (LPC I/F—D31:F0)

I/O Address: Ch. #0–3 = 0Dh;
 Ch. #4–7 = DAh Attribute: WO
 Default Value: xxxx xxxx Size: 8-bit

Bit	Description
7:0	Master Clear — WO. No specific pattern. Enabled with a write to the port. This has the same effect as the hardware Reset. The Command, Status, Request, and Byte Pointer flip/flop registers are cleared and the Mask Register is set.

10.2.10 DMA_CLMSK—DMA Clear Mask Register (LPC I/F—D31:F0)

I/O Address: Ch. #0–3 = 0Eh;
 Ch. #4–7 = DCh Attribute: WO
 Default Value: xxxx xxxx Size: 8-bit
 Lockable: No Power Well: Core

Bit	Description
7:0	Clear Mask Register — WO. No specific pattern. Command enabled with a write to the port.

10.2.11 DMA_WRMSK—DMA Write All Mask Register (LPC I/F—D31:F0)

I/O Address: Ch. #0–3 = 0Fh;
 Ch. #4–7 = DEh Attribute: R/W
 Default Value: 0000 1111 Size: 8-bit
 Lockable: No Power Well: Core

Bit	Description
7:4	Reserved. Must be 0.
3:0	<p>Channel Mask Bits — R/W. This register permits all four channels to be simultaneously enabled/disabled instead of enabling/disabling each channel individually, as is the case with the Mask Register – Write Single Mask Bit. In addition, this register has a read path to allow the status of the channel mask bits to be read. A channel's mask bit is automatically set to 1 when the Current Byte/Word Count Register reaches terminal count (unless the channel is in auto-initialization mode).</p> <p>Setting the bit(s) to a 1 disables the corresponding DREQ(s). Setting the bit(s) to a 0 enables the corresponding DREQ(s). Bits [3:0] are set to 1 upon part reset or Master Clear. When read, bits [3:0] indicate the DMA channel [3:0] ([7:4]) mask status.</p> <p>Bit 0 = Channel 0 (4) 1 = Masked, 0 = Not Masked Bit 1 = Channel 1 (5) 1 = Masked, 0 = Not Masked Bit 2 = Channel 2 (6) 1 = Masked, 0 = Not Masked Bit 3 = Channel 3 (7) 1 = Masked, 0 = Not Masked</p> <p>NOTE: Disabling channel 4 also disables channels 0–3 due to the cascade of channel's 0–3 through channel 4.</p>

10.3 Timer I/O Registers (LPC I/F—D31:F0)

Port	Aliases	Register Name	Default Value	Type
40h	50h	Counter 0 Interval Time Status Byte Format	0XXXXXXXb	RO
		Counter 0 Counter Access Port	Undefined	R/W
41h	51h	Counter 1 Interval Time Status Byte Format	0XXXXXXXb	RO
		Counter 1 Counter Access Port	Undefined	R/W
42h	52h	Counter 2 Interval Time Status Byte Format	0XXXXXXXb	RO
		Counter 2 Counter Access Port	Undefined	R/W
43h	53h	Timer Control Word	Undefined	WO
		Timer Control Word Register	XXXXXXXX0b	WO
		Counter Latch Command	X0h	WO

RDBK_CMD—Read Back Command (LPC I/F—D31:F0)

The Read Back Command is used to determine the count value, programmed mode, and current states of the OUT pin and Null count flag of the selected counter or counters. Status and/or count may be latched in any or all of the counters by selecting the counter during the register write. The count and status remain latched until read, and further latch commands are ignored until the count is read. Both count and status of the selected counters may be latched simultaneously by setting both bit 5 and bit 4 to 0. If both are latched, the first read operation from that counter returns the latched status. The next one or two reads, depending on whether the counter is programmed for one or two byte counts, returns the latched count. Subsequent reads return an unlatched count.

Bit	Description
7:6	Read Back Command. Must be 11 to select the Read Back Command
5	Latch Count of Selected Counters. 0 = Current count value of the selected counters will be latched 1 = Current count will not be latched
4	Latch Status of Selected Counters. 0 = Status of the selected counters will be latched 1 = Status will not be latched
3	Counter 2 Select. 1 = Counter 2 count and/or status will be latched
2	Counter 1 Select. 1 = Counter 1 count and/or status will be latched
1	Counter 0 Select. 1 = Counter 0 count and/or status will be latched.
0	Reserved. Must be 0.

LTCH_CMD—Counter Latch Command (LPC I/F—D31:F0)

The Counter Latch Command latches the current count value. This command is used to insure that the count read from the counter is accurate. The count value is then read from each counter's count register through the Counter Ports Access Ports Register (40h for counter 0, 41h for counter 1, and 42h for counter 2). The count must be read according to the programmed format, i.e., if the counter is programmed for two byte counts, two bytes must be read. The two bytes do not have to be read one right after the other (read, write, or programming operations for other counters may be inserted between the reads). If a counter is latched once and then latched again before the count is read, the second Counter Latch Command is ignored.

Bit	Description
7:6	Counter Selection. These bits select the counter for latching. If "11" is written, then the write is interpreted as a read back command. 00 = Counter 0 01 = Counter 1 10 = Counter 2
5:4	Counter Latch Command. 00 = Selects the Counter Latch Command.
3:0	Reserved. Must be 0.

10.3.2 SBYTE_FMT—Interval Timer Status Byte Format Register (LPC I/F—D31:F0)

I/O Address: Counter 0 = 40h,
 Counter 1 = 41h, Attribute: RO
 Counter 2 = 42h Size: 8 bits per counter
 Default Value: Bits[6:0] undefined, Bit 7=0

Each counter's status byte can be read following a Read Back Command. If latch status is chosen (bit 4=0, Read Back Command) as a read back option for a given counter, the next read from the counter's Counter Access Ports Register (40h for counter 0, 41h for counter 1, and 42h for counter 2) returns the status byte. The status byte returns the following:

Bit	Description
7	Counter OUT Pin State — RO. 0 = OUT pin of the counter is also a 0 1 = OUT pin of the counter is also a 1
6	Count Register Status — RO. This bit indicates when the last count written to the Count Register (CR) has been loaded into the counting element (CE). The exact time this happens depends on the counter mode, but until the count is loaded into the counting element (CE), the count value will be incorrect. 0 = Count has been transferred from CR to CE and is available for reading. 1 = Null Count. Count has not been transferred from CR to CE and is not yet available for reading.
5:4	Read/Write Selection Status — RO. These bits reflect the read/write selection made through bits[5:4] of the control register. The binary codes returned during the status read match the codes used to program the counter read/write selection. 00 = Counter Latch Command 01 = Read/Write Least Significant Byte (LSB) 10 = Read/Write Most Significant Byte (MSB) 11 = Read/Write LSB then MSB
3:1	Mode Selection Status — RO. These bits return the counter mode programming. The binary code returned matches the code used to program the counter mode, as listed under the bit function above. 000 = Mode 0 — Out signal on end of count (=0) 001 = Mode 1 — Hardware retriggerable one-shot x10 = Mode 2 — Rate generator (divide by n counter) x11 = Mode 3 — Square wave output 100 = Mode 4 — Software triggered strobe 101 = Mode 5 — Hardware triggered strobe
0	Countdown Type Status — RO. This bit reflects the current countdown type. 0 = Binary countdown 1 = Binary Coded Decimal (BCD) countdown.

10.3.3 Counter Access Ports Register (LPC I/F—D31:F0)

I/O Address:	Counter 0 – 40h, Counter 1 – 41h, Counter 2 – 42h	Attribute:	R/W
Default Value:	All bits undefined	Size:	8 bit

Bit	Description
7:0	Counter Port — R/W. Each counter port address is used to program the 16-bit Count Register. The order of programming, either LSB only, MSB only, or LSB then MSB, is defined with the Interval Counter Control Register at port 43h. The counter port is also used to read the current count from the Count Register, and return the status of the counter programming following a Read Back Command.

10.4 8259 Interrupt Controller (PIC) Registers (LPC I/F—D31:F0)

10.4.1 Interrupt Controller I/O MAP (LPC I/F—D31:F0)

The interrupt controller registers are located at 20h and 21h for the master controller (IRQ 0–7), and at A0h and A1h for the slave controller (IRQ 8–13). These registers have multiple functions, depending upon the data written to them. Table 10-3 shows the different register possibilities for each address.

Table 10-3. PIC Registers (LPC I/F—D31:F0)

Port	Aliases	Register Name	Default Value	Type
20h	24h, 28h, 2Ch, 30h, 34h, 38h, 3Ch	Master PIC ICW1 Init. Cmd Word 1	Undefined	WO
		Master PIC OCW2 Op Ctrl Word 2	001XXXXXb	WO
		Master PIC OCW3 Op Ctrl Word 3	X01XXX10b	WO
21h	25h, 29h, 2Dh, 31h, 35h, 39h, 3Dh	Master PIC ICW2 Init. Cmd Word 2	Undefined	WO
		Master PIC ICW3 Init. Cmd Word 3	Undefined	WO
		Master PIC ICW4 Init. Cmd Word 4	01h	WO
		Master PIC OCW1 Op Ctrl Word 1	00h	R/W
A0h	A4h, A8h, ACh, B0h, B4h, B8h, BCh	Slave PIC ICW1 Init. Cmd Word 1	Undefined	WO
		Slave PIC OCW2 Op Ctrl Word 2	001XXXXXb	WO
		Slave PIC OCW3 Op Ctrl Word 3	X01XXX10b	WO
A1h	A5h, A9h, ADh, B1h, B5h, B9h, BDh	Slave PIC ICW2 Init. Cmd Word 2	Undefined	WO
		Slave PIC ICW3 Init. Cmd Word 3	Undefined	WO
		Slave PIC ICW4 Init. Cmd Word 4	01h	WO
		Slave PIC OCW1 Op Ctrl Word 1	00h	R/W
4D0h	–	Master PIC Edge/Level Triggered	00h	R/W
4D1h	–	Slave PIC Edge/Level Triggered	00h	R/W

Note: Refer to note addressing active-low interrupt sources in 8259 Interrupt Controllers section (Chapter 5.9).

10.4.2 ICW1—Initialization Command Word 1 Register (LPC I/F—D31:F0)

Offset Address: Master Controller – 20h Attribute: WO
 Slave Controller – A0h Size: 8 bit /controller
 Default Value: All bits undefined

A write to Initialization Command Word 1 starts the interrupt controller initialization sequence, during which the following occurs:

1. The Interrupt Mask register is cleared.
2. IRQ7 input is assigned priority 7.
3. The slave mode address is set to 7.
4. Special mask mode is cleared and Status Read is set to IRR.

Once this write occurs, the controller expects writes to ICW2, ICW3, and ICW4 to complete the initialization sequence.

Bit	Description
7:5	ICW/OCW Select — WO. These bits are MCS-85 specific, and not needed. 000 = Should be programmed to “000”
4	ICW/OCW Select — WO. 1 = This bit must be a 1 to select ICW1 and enable the ICW2, ICW3, and ICW4 sequence.
3	Edge/Level Bank Select (LTIM) — WO. Disabled. Replaced by the edge/level triggered control registers (ELCR, D31:F0:4D0h, D31:F0:4D1h).
2	ADI — WO. 0 = Ignored for the ICH6. Should be programmed to 0.
1	Single or Cascade (SNGL) — WO. 0 = Must be programmed to a 0 to indicate two controllers operating in cascade mode.
0	ICW4 Write Required (IC4) — WO. 1 = This bit must be programmed to a 1 to indicate that ICW4 needs to be programmed.

10.4.3 ICW2—Initialization Command Word 2 Register (LPC I/F—D31:F0)

Offset Address:	Master Controller – 21h Slave Controller – A1h	Attribute:	WO
Default Value:	All bits undefined	Size:	8 bit /controller

ICW2 is used to initialize the interrupt controller with the five most significant bits of the interrupt vector address. The value programmed for bits[7:3] is used by the processor to define the base address in the interrupt vector table for the interrupt routines associated with each IRQ on the controller. Typical ISA ICW2 values are 08h for the master controller and 70h for the slave controller.

Bit	Description																											
7:3	Interrupt Vector Base Address — WO. Bits [7:3] define the base address in the interrupt vector table for the interrupt routines associated with each interrupt request level input.																											
2:0	<p>Interrupt Request Level — WO. When writing ICW2, these bits should all be 0. During an interrupt acknowledge cycle, these bits are programmed by the interrupt controller with the interrupt to be serviced. This is combined with bits [7:3] to form the interrupt vector driven onto the data bus during the second INTA# cycle. The code is a three bit binary code:</p> <table border="1"> <thead> <tr> <th>Code</th> <th>Master Interrupt</th> <th>Slave Interrupt</th> </tr> </thead> <tbody> <tr> <td>000b</td> <td>IRQ0</td> <td>IRQ8</td> </tr> <tr> <td>001b</td> <td>IRQ1</td> <td>IRQ9</td> </tr> <tr> <td>010b</td> <td>IRQ2</td> <td>IRQ10</td> </tr> <tr> <td>011b</td> <td>IRQ3</td> <td>IRQ11</td> </tr> <tr> <td>100b</td> <td>IRQ4</td> <td>IRQ12</td> </tr> <tr> <td>101b</td> <td>IRQ5</td> <td>IRQ13</td> </tr> <tr> <td>110b</td> <td>IRQ6</td> <td>IRQ14</td> </tr> <tr> <td>111b</td> <td>IRQ7</td> <td>IRQ15</td> </tr> </tbody> </table>	Code	Master Interrupt	Slave Interrupt	000b	IRQ0	IRQ8	001b	IRQ1	IRQ9	010b	IRQ2	IRQ10	011b	IRQ3	IRQ11	100b	IRQ4	IRQ12	101b	IRQ5	IRQ13	110b	IRQ6	IRQ14	111b	IRQ7	IRQ15
Code	Master Interrupt	Slave Interrupt																										
000b	IRQ0	IRQ8																										
001b	IRQ1	IRQ9																										
010b	IRQ2	IRQ10																										
011b	IRQ3	IRQ11																										
100b	IRQ4	IRQ12																										
101b	IRQ5	IRQ13																										
110b	IRQ6	IRQ14																										
111b	IRQ7	IRQ15																										

10.4.4 ICW3—Master Controller Initialization Command Word 3 Register (LPC I/F—D31:F0)

Offset Address:	21h	Attribute:	WO
Default Value:	All bits undefined	Size:	8 bits

Bit	Description
7:3	0 = These bits must be programmed to 0.
2	<p>Cascaded Interrupt Controller IRQ Connection — WO. This bit indicates that the slave controller is cascaded on IRQ2. When IRQ8#–IRQ15 is asserted, it goes through the slave controller's priority resolver. The slave controller's INTR output onto IRQ2. IRQ2 then goes through the master controller's priority solver. If it wins, the INTR signal is asserted to the processor, and the returning interrupt acknowledge returns the interrupt vector for the slave controller.</p> <p>1 = This bit must always be programmed to a 1.</p>
1:0	0 = These bits must be programmed to 0.

10.4.7 OCW1—Operational Control Word 1 (Interrupt Mask) Register (LPC I/F—D31:F0)

Offset Address: Master Controller – 021h Attribute: R/W
 Slave Controller – 0A1h Size: 8 bits
 Default Value: 00h

Bit	Description
7:0	Interrupt Request Mask — R/W. When a 1 is written to any bit in this register, the corresponding IRQ line is masked. When a 0 is written to any bit in this register, the corresponding IRQ mask bit is cleared, and interrupt requests will again be accepted by the controller. Masking IRQ2 on the master controller will also mask the interrupt requests from the slave controller.

10.4.8 OCW2—Operational Control Word 2 Register (LPC I/F—D31:F0)

Offset Address: Master Controller – 020h Attribute: WO
 Slave Controller – 0A0h Size: 8 bits
 Default Value: Bit[4:0]=undefined, Bit[7:5]=001

Following a part reset or ICW initialization, the controller enters the fully nested mode of operation. Non-specific EOI without rotation is the default. Both rotation mode and specific EOI mode are disabled following initialization.

Bit	Description																				
7:5	Rotate and EOI Codes (R, SL, EOI) — WO. These three bits control the Rotate and End of Interrupt modes and combinations of the two. 000 = Rotate in Auto EOI Mode (Clear) 001 = Non-specific EOI command 010 = No Operation 011 = *Specific EOI Command 100 = Rotate in Auto EOI Mode (Set) 101 = Rotate on Non-Specific EOI Command 110 = *Set Priority Command 111 = *Rotate on Specific EOI Command *L0 – L2 Are Used																				
4:3	OCW2 Select — WO. When selecting OCW2, bits 4:3 = "00"																				
2:0	Interrupt Level Select (L2, L1, L0) — WO. L2, L1, and L0 determine the interrupt level acted upon when the SL bit is active. A simple binary code, outlined below, selects the channel for the command to act upon. When the SL bit is inactive, these bits do not have a defined function; programming L2, L1 and L0 to 0 is sufficient in this case.																				
	<table border="1"> <thead> <tr> <th>Code</th> <th>Interrupt Level</th> <th>Code</th> <th>Interrupt Level</th> </tr> </thead> <tbody> <tr> <td>000b</td> <td>IRQ0/8</td> <td>000b</td> <td>IRQ4/12</td> </tr> <tr> <td>001b</td> <td>IRQ1/9</td> <td>001b</td> <td>IRQ5/13</td> </tr> <tr> <td>010b</td> <td>IRQ2/10</td> <td>010b</td> <td>IRQ6/14</td> </tr> <tr> <td>011b</td> <td>IRQ3/11</td> <td>011b</td> <td>IRQ7/15</td> </tr> </tbody> </table>	Code	Interrupt Level	Code	Interrupt Level	000b	IRQ0/8	000b	IRQ4/12	001b	IRQ1/9	001b	IRQ5/13	010b	IRQ2/10	010b	IRQ6/14	011b	IRQ3/11	011b	IRQ7/15
Code	Interrupt Level	Code	Interrupt Level																		
000b	IRQ0/8	000b	IRQ4/12																		
001b	IRQ1/9	001b	IRQ5/13																		
010b	IRQ2/10	010b	IRQ6/14																		
011b	IRQ3/11	011b	IRQ7/15																		

10.4.9 OCW3—Operational Control Word 3 Register (LPC I/F—D31:F0)

Offset Address: Master Controller – 020h Attribute: WO
 Slave Controller – 0A0h Size: 8 bits
 Default Value: Bit[6,0]=0, Bit[7,4:2]=undefined,
 Bit[5,1]=1

Bit	Description
7	Reserved. Must be 0.
6	Special Mask Mode (SMM) — WO. 1 = The Special Mask Mode can be used by an interrupt service routine to dynamically alter the system priority structure while the routine is executing, through selective enabling/disabling of the other channel's mask bits. Bit 5, the ESMM bit, must be set for this bit to have any meaning.
5	Enable Special Mask Mode (ESMM) — WO. 0 = Disable. The SMM bit becomes a “don't care”. 1 = Enable the SMM bit to set or reset the Special Mask Mode.
4:3	OCW3 Select — WO. When selecting OCW3, bits 4:3 = 01
2	Poll Mode Command — WO. 0 = Disable. Poll Command is not issued. 1 = Enable. The next I/O read to the interrupt controller is treated as an interrupt acknowledge cycle. An encoded byte is driven onto the data bus, representing the highest priority level requesting service.
1:0	Register Read Command — WO. These bits provide control for reading the In-Service Register (ISR) and the Interrupt Request Register (IRR). When bit 1=0, bit 0 will not affect the register read selection. When bit 1=1, bit 0 selects the register status returned following an OCW3 read. If bit 0=0, the IRR will be read. If bit 0=1, the ISR will be read. Following ICW initialization, the default OCW3 port address read will be “read IRR”. To retain the current selection (read ISR or read IRR), always write a 0 to bit 1 when programming this register. The selected register can be read repeatedly without reprogramming OCW3. To select a new status register, OCW3 must be reprogrammed prior to attempting the read. 00 = No Action 01 = No Action 10 = Read IRQ Register 11 = Read IS Register

10.4.11 ELCR2—Slave Controller Edge/Level Triggered Register (LPC I/F—D31:F0)

Offset Address: 4D1h
 Default Value: 00h

Attribute: R/W
 Size: 8 bits

In edge mode, (bit[x] = 0), the interrupt is recognized by a low to high transition. In level mode (bit[x] = 1), the interrupt is recognized by a high level. The real time clock, IRQ8#, and the floating point error interrupt, IRQ13, cannot be programmed for level mode.

Bit	Description
7	IRQ15 ECL — R/W. 0 = Edge 1 = Level
6	IRQ14 ECL — R/W. 0 = Edge 1 = Level
5	Reserved. Must be 0.
4	IRQ12 ECL — R/W. 0 = Edge 1 = Level
3	IRQ11 ECL — R/W. 0 = Edge 1 = Level
2	IRQ10 ECL — R/W. 0 = Edge 1 = Level
1	IRQ9 ECL — R/W. 0 = Edge 1 = Level
0	Reserved. Must be 0.

10.5 Advanced Programmable Interrupt Controller (APIC)(D31:F0)

10.5.1 APIC Register Map (LPC I/F—D31:F0)

The APIC is accessed via an indirect addressing scheme. Two registers are visible by software for manipulation of most of the APIC registers. These registers are mapped into memory space. The registers are shown in Table 10-4.

Table 10-4. APIC Direct Registers (LPC I/F—D31:F0)

Address	Mnemonic	Register Name	Size	Type
FEC0_0000h	IND	Index	8 bits	R/W
FEC0_0010h	DAT	Data	32 bits	R/W
FEC0_0040h	EOIR	EOI	32 bits	WO

Table 10-5 lists the registers which can be accessed within the APIC via the Index Register. When accessing these registers, accesses must be done one DWord at a time. For example, software should never access byte 2 from the Data register before accessing bytes 0 and 1. The hardware will not attempt to recover from a bad programming model in this case.

Table 10-5. APIC Indirect Registers (LPC I/F—D31:F0)

Index	Mnemonic	Register Name	Size	Type
00	ID	Identification	32 bits	R/W
01	VER	Version	32 bits	RO
02-0F	—	Reserved	—	RO
10-11	REDIR_TBL0	Redirection Table 0	64 bits	R/W, RO
12-13	REDIR_TBL1	Redirection Table 1	64 bits	R/W, RO
...
3E-3F	REDIR_TBL23	Redirection Table 23	64 bits	R/W, RO
40-FF	—	Reserved	—	RO

10.5.2 IND—Index Register (LPC I/F—D31:F0)

Memory Address FEC0_0000h Attribute: R/W
 Default Value: 00h Size: 8 bits

The Index Register will select which APIC indirect register to be manipulated by software. The selector values for the indirect registers are listed in Table 10-5. Software will program this register to select the desired APIC internal register

Bit	Description
7:0	APIC Index — R/W. This is an 8-bit pointer into the I/O APIC register table.

10.5.3 DAT—Data Register (LPC I/F—D31:F0)

Memory Address FEC0_0010h Attribute: R/W
 Default Value: 00000000h Size: 32 bits

This is a 32-bit register specifying the data to be read or written to the register pointed to by the Index register. This register can only be accessed in DWord quantities.

Bit	Description
7:0	APIC Data — R/W. This is a 32-bit register for the data to be read or written to the APIC indirect register (Figure 10-5) pointed to by the Index register (Memory Address FEC0_0000h).

10.5.4 EOIR—EOI Register (LPC I/F—D31:F0)

Memory Address FEC0_0040h Attribute: WO
 Default Value: N/A Size: 32 bits

The EOI register is present to provide a mechanism to maintain the level triggered semantics for level-triggered interrupts issued on the parallel bus.

When a write is issued to this register, the I/O APIC will check the lower 8 bits written to this register, and compare it with the vector field for each entry in the I/O Redirection Table. When a match is found, the Remote_IRR bit (Index Offset 10h, bit 14) for that I/O Redirection Entry will be cleared.

Note: If multiple I/O Redirection entries, for any reason, assign the same vector for more than one interrupt input, each of those entries will have the Remote_IRR bit reset to 0. The interrupt which was prematurely reset will not be lost because if its input remained active when the Remote_IRR bit is cleared, the interrupt will be reissued and serviced at a later time. Note: Only bits 7:0 are actually used. Bits 31:8 are ignored by the ICH6.

Note: To provide for future expansion, the processor should always write a value of 0 to Bits 31:8.

Bit	Description
31:8	Reserved. To provide for future expansion, the processor should always write a value of 0 to Bits 31:8.
7:0	Redirection Entry Clear — WO. When a write is issued to this register, the I/O APIC will check this field, and compare it with the vector field for each entry in the I/O Redirection Table. When a match is found, the Remote_IRR bit for that I/O Redirection Entry will be cleared.

10.5.5 ID—Identification Register (LPC I/F—D31:F0)

Index Offset:	00h	Attribute:	R/W
Default Value:	00000000h	Size:	32 bits

The APIC ID serves as a physical name of the APIC. The APIC bus arbitration ID for the APIC is derived from its I/O APIC ID. This register is reset to 0 on power-up reset.

Bit	Description
31:28	Reserved
27:24	APIC ID — R/W. Software must program this value before using the APIC.
23:16	Reserved
15	Scratchpad Bit.
14:0	Reserved

10.5.6 VER—Version Register (LPC I/F—D31:F0)

Index Offset:	01h	Attribute:	RO
Default Value:	00170020h	Size:	32 bits

Each I/O APIC contains a hardwired Version Register that identifies different implementation of APIC and their versions. The maximum redirection entry information also is in this register, to let software know how many interrupt are supported by this APIC.

Bit	Description
31:24	Reserved
23:16	Maximum Redirection Entries — RO. This is the entry number (0 being the lowest entry) of the highest entry in the redirection table. It is equal to the number of interrupt input pins minus one and is in the range 0 through 239. In the ICH6 this field is hardwired to 17h to indicate 24 interrupts.
15	PRQ — RO. This bit indicate that the IOxAPIC does not implement the Pin Assertion Register.
14:8	Reserved
7:0	Version — RO. This is a version number that identifies the implementation version.

10.5.7 REDIR_TBL—Redirection Table (LPC I/F—D31:F0)

Index Offset:	10h–11h (vector 0) through 3E–3Fh (vector 23)	Attribute:	R/W, RO
Default Value:	Bit 16 = 1, All other bits undefined	Size:	64 bits each, (accessed as two 32 bit quantities)

The Redirection Table has a dedicated entry for each interrupt input pin. The information in the Redirection Table is used to translate the interrupt manifestation on the corresponding interrupt pin into an APIC message.

The APIC will respond to an edge triggered interrupt as long as the interrupt is held until after the acknowledge cycle has begun. Once the interrupt is detected, a delivery status bit internally to the I/O APIC is set. The state machine will step ahead and wait for an acknowledgment from the APIC unit that the interrupt message was sent. Only then will the I/O APIC be able to recognize a new edge on that interrupt pin. That new edge will only result in a new invocation of the handler if its acceptance by the destination APIC causes the Interrupt Request Register bit to go from 0 to 1. (In other words, if the interrupt was not already pending at the destination.)

Bit	Description
63:56	Destination — R/W. If bit 11 of this entry is 0 (Physical), then bits 59:56 specifies an APIC ID. In this case, bits 63:59 should be programmed by software to 0. If bit 11 of this entry is 1 (Logical), then bits 63:56 specify the logical destination address of a set of processors.
55:48	Extended Destination ID (EDID) — RO. These bits are sent to a local APIC only when in Processor System Bus mode. They become bits 11:4 of the address.
47:17	Reserved
16	Mask — R/W. 0 = Not masked: An edge or level on this interrupt pin results in the delivery of the interrupt to the destination. 1 = Masked: Interrupts are not delivered nor held pending. Setting this bit after the interrupt is accepted by a local APIC has no effect on that interrupt. This behavior is identical to the device withdrawing the interrupt before it is posted to the processor. It is software's responsibility to deal with the case where the mask bit is set after the interrupt message has been accepted by a local APIC unit but before the interrupt is dispensed to the processor.
15	Trigger Mode — R/W. This field indicates the type of signal on the interrupt pin that triggers an interrupt. 0 = Edge triggered. 1 = Level triggered.
14	Remote IRR — R/W. This bit is used for level triggered interrupts; its meaning is undefined for edge triggered interrupts. 0 = Reset when an EOI message is received from a local APIC. 1 = Set when Local APIC/s accept the level interrupt sent by the I/O APIC.
13	Interrupt Input Pin Polarity — R/W. This bit specifies the polarity of each interrupt signal connected to the interrupt pins. 0 = Active high. 1 = Active low.
12	Delivery Status — RO. This field contains the current status of the delivery of this interrupt. Writes to this bit have no effect. 0 = Idle. No activity for this interrupt. 1 = Pending. Interrupt has been injected, but delivery is not complete.

Bit	Description
11	Destination Mode — R/W. This field determines the interpretation of the Destination field. 0 = Physical. Destination APIC ID is identified by bits 59:56. 1 = Logical. Destinations are identified by matching bit 63:56 with the Logical Destination in the Destination Format Register and Logical Destination Register in each Local APIC.
10:8	Delivery Mode — R/W. This field specifies how the APICs listed in the destination field should act upon reception of this signal. Certain Delivery Modes will only operate as intended when used in conjunction with a specific trigger mode. These encodings are listed in the note below:
7:0	Vector — R/W. This field contains the interrupt vector for this interrupt. Values range between 10h and FEh.

NOTE: Delivery Mode encoding:

000 = Fixed. Deliver the signal on the INTR signal of all processor cores listed in the destination. Trigger Mode can be edge or level.

001 = Lowest Priority. Deliver the signal on the INTR signal of the processor core that is executing at the lowest priority among all the processors listed in the specified destination. Trigger Mode can be edge or level.

010 = SMI (System Management Interrupt). Requires the interrupt to be programmed as edge triggered. The vector information is ignored but must be programmed to all 0's for future compatibility: **not supported**

011 = Reserved

100 = NMI. Deliver the signal on the NMI signal of all processor cores listed in the destination. Vector information is ignored. NMI is treated as an edge triggered interrupt even if it is programmed as level triggered. For proper operation this redirection table entry must be programmed to edge triggered. The NMI delivery mode does not set the RIRR bit. If the redirection table is incorrectly set to level, the loop count will continue counting through the redirection table addresses. Once the count for the NMI pin is reached again, the interrupt will be sent again: **not supported**

101 = INIT. Deliver the signal to all processor cores listed in the destination by asserting the INIT signal. All addressed local APICs will assume their INIT state. INIT is always treated as an edge triggered interrupt even if programmed as level triggered. For proper operation this redirection table entry must be programmed to edge triggered. The INIT delivery mode does not set the RIRR bit. If the redirection table is incorrectly set to level, the loop count will continue counting through the redirection table addresses. Once the count for the INIT pin is reached again, the interrupt will be sent again: **not supported**

110 = Reserved

111 = ExtINT. Deliver the signal to the INTR signal of all processor cores listed in the destination as an interrupt that originated in an externally connected 8259A compatible interrupt controller. The INTA cycle that corresponds to this ExtINT delivery will be routed to the external controller that is expected to supply the vector. Requires the interrupt to be programmed as edge triggered.

10.6 Real Time Clock Registers (LPC I/F—D31:F0)

10.6.1 I/O Register Address Map (LPC I/F—D31:F0)

The RTC internal registers and RAM are organized as two banks of 128 bytes each, called the standard and extended banks. The first 14 bytes of the standard bank contain the RTC time and date information along with four registers, A–D, that are used for configuration of the RTC. The extended bank contains a full 128 bytes of battery backed SRAM, and will be accessible even when the RTC module is disabled (via the RTC configuration register). Registers A–D do not physically exist in the RAM.

All data movement between the host processor and the real-time clock is done through registers mapped to the standard I/O space. The register map appears in [Table 10-6](#).

Table 10-6. RTC I/O Registers (LPC I/F—D31:F0)

I/O Locations	If U128E bit = 0	Function
70h and 74h	Also alias to 72h and 76h	Real-Time Clock (Standard RAM) Index Register
71h and 75h	Also alias to 73h and 77h	Real-Time Clock (Standard RAM) Target Register
72h and 76h		Extended RAM Index Register (if enabled)
73h and 77h		Extended RAM Target Register (if enabled)

NOTES:

1. I/O locations 70h and 71h are the standard legacy location for the real-time clock. The map for this bank is shown in [Table 10-7](#). Locations 72h and 73h are for accessing the extended RAM. The extended RAM bank is also accessed using an indexed scheme. I/O address 72h is used as the address pointer and I/O address 73h is used as the data register. Index addresses above 127h are not valid. If the extended RAM is not needed, it may be disabled.
2. Software must preserve the value of bit 7 at I/O addresses 70h and 74h. When writing to this address, software must first read the value, and then write the same value for bit 7 during the sequential address write. Note that port 70h is not directly readable. The only way to read this register is through Alt Access mode. Although RTC Index bits 6:0 are readable from port 74h, bit 7 will always return 0. If the NMI# enable is not changed during normal operation, software can alternatively read this bit once and then retain the value for all subsequent writes to port 70h.

10.6.2 Indexed Registers (LPC I/F—D31:F0)

The RTC contains two sets of indexed registers that are accessed using the two separate Index and Target registers (70/71h or 72/73h), as shown in [Table 10-7](#).

Table 10-7. RTC (Standard) RAM Bank (LPC I/F—D31:F0)

Index	Name
00h	Seconds
01h	Seconds Alarm
02h	Minutes
03h	Minutes Alarm
04h	Hours
05h	Hours Alarm
06h	Day of Week
07h	Day of Month
08h	Month
09h	Year
0Ah	Register A
0Bh	Register B
0Ch	Register C
0Dh	Register D
0Eh–7Fh	114 Bytes of User RAM

10.6.2.1 RTC_REGA—Register A (LPC I/F—D31:F0)

RTC Index:	0A	Attribute:	R/W
Default Value:	Undefined	Size:	8-bit
Lockable:	No	Power Well:	RTC

This register is used for general configuration of the RTC functions. None of the bits are affected by RSMRST# or any other ICH6 reset signal.

Bit	Description
7	<p>Update In Progress (UIP) — R/W. This bit may be monitored as a status flag.</p> <p>0 = The update cycle will not start for at least 488 μs. The time, calendar, and alarm information in RAM is always available when the UIP bit is 0.</p> <p>1 = The update is soon to occur or is in progress.</p>
6:4	<p>Division Chain Select (DV[2:0]) — R/W. These three bits control the divider chain for the oscillator, and are not affected by RSMRST# or any other reset signal. DV2 corresponds to bit 6.</p> <p>010 = Normal Operation</p> <p>11X = Divider Reset</p> <p>101 = Bypass 15 stages (test mode only)</p> <p>100 = Bypass 10 stages (test mode only)</p> <p>011 = Bypass 5 stages (test mode only)</p> <p>001 = Invalid</p> <p>000 = Invalid</p>
3:0	<p>Rate Select (RS[3:0]) — R/W. These bits selects one of 13 taps of the 15 stage divider chain. The selected tap can generate a periodic interrupt if the PIE bit is set in Register B. Otherwise this tap will set the PF flag of Register C. If the periodic interrupt is not to be used, these bits should all be set to 0. RS3 corresponds to bit 3.</p> <p>0000 = Interrupt never toggles</p> <p>0001 = 3.90625 ms</p> <p>0010 = 7.8125 ms</p> <p>0011 = 122.070 μs</p> <p>0100 = 244.141 μs</p> <p>0101 = 488.281 μs</p> <p>0110 = 976.5625 μs</p> <p>0111 = 1.953125 ms</p> <p>1000 = 3.90625 ms</p> <p>1001 = 7.8125 ms</p> <p>1010 = 15.625 ms</p> <p>1011 = 31.25 ms</p> <p>1100 = 62.5 ms</p> <p>1101 = 125 ms</p> <p>1110 = 250 ms</p> <p>1111 = 500 ms</p>

10.6.2.2 RTC_REGB—Register B (General Configuration) (LPC I/F—D31:F0)

RTC Index: 0Bh Attribute: R/W
 Default Value: U0U00UUU (U: Undefined) Size: 8-bit
 Lockable: No Power Well: RTC

Bit	Description
7	<p>Update Cycle Inhibit (SET) — R/W. This bit enables/Inhibits the update cycles. This bit is not affected by RSMRST# nor any other reset signal.</p> <p>0 = Update cycle occurs normally once each second. 1 = A current update cycle will abort and subsequent update cycles will not occur until SET is returned to 0. When set is one, the BIOS may initialize time and calendar bytes safely.</p> <p>NOTE: This bit should be set then cleared early in BIOS POST after each powerup directly after coin-cell battery insertion.</p>
6	<p>Periodic Interrupt Enable (PIE) — R/W. This bit is cleared by RSMRST#, but not on any other reset.</p> <p>0 = Disable. 1 = Enable. Allows an interrupt to occur with a time base set with the RS bits of register A.</p>
5	<p>Alarm Interrupt Enable (AIE) — R/W. This bit is cleared by RTCRST#, but not on any other reset.</p> <p>0 = Disable. 1 = Enable. Allows an interrupt to occur when the AF is set by an alarm match from the update cycle. An alarm can occur once a second, one an hour, once a day, or one a month.</p>
4	<p>Update-Ended Interrupt Enable (UIE) — R/W. This bit is cleared by RSMRST#, but not on any other reset.</p> <p>0 = Disable. 1 = Enable. Allows an interrupt to occur when the update cycle ends.</p>
3	<p>Square Wave Enable (SQWE) — R/W. This bit serves no function in the ICH6. It is left in this register bank to provide compatibility with the Motorola 146818B. The ICH6 has no SQW pin. This bit is cleared by RSMRST#, but not on any other reset.</p>
2	<p>Data Mode (DM) — R/W. This bit specifies either binary or BCD data representation. This bit is not affected by RSMRST# nor any other reset signal.</p> <p>0 = BCD 1 = Binary</p>
1	<p>Hour Format (HOURFORM) — R/W. This bit indicates the hour byte format. This bit is not affected by RSMRST# nor any other reset signal.</p> <p>0 = Twelve-hour mode. In twelve-hour mode, the seventh bit represents AM as 0 and PM as one. 1 = Twenty-four hour mode.</p>
0	<p>Daylight Savings Enable (DSE) — R/W. This bit triggers two special hour updates per year. The days for the hour adjustment are those specified in United States federal law as of 1987, which is different than previous years. This bit is not affected by RSMRST# nor any other reset signal.</p> <p>0 = Daylight Savings Time updates do not occur. 1 = a) Update on the first Sunday in April, where time increments from 1:59:59 AM to 3:00:00 AM. b) Update on the last Sunday in October when the time first reaches 1:59:59 AM, it is changed to 1:00:00 AM. The time must increment normally for at least two update cycles (seconds) previous to these conditions for the time change to occur properly.</p>

10.6.2.3 RTC_REGC—Register C (Flag Register) (LPC I/F—D31:F0)

RTC Index:	0Ch	Attribute:	RO
Default Value:	00U00000 (U: Undefined)	Size:	8-bit
Lockable:	No	Power Well:	RTC

Writes to Register C have no effect.

Bit	Description
7	Interrupt Request Flag (IRQF) — RO. $IRQF = (PF * PIE) + (AF * AIE) + (UF * UFE)$. This bit also causes the RTC Interrupt to be asserted. This bit is cleared upon RSMRST# or a read of Register C.
6	Periodic Interrupt Flag (PF) — RO. This bit is cleared upon RSMRST# or a read of Register C. 0 = If no taps are specified via the RS bits in Register A, this flag will not be set. 1 = Periodic interrupt Flag will be 1 when the tap specified by the RS bits of register A is 1.
5	Alarm Flag (AF) — RO. 0 = This bit is cleared upon RTCRST# or a read of Register C. 1 = Alarm Flag will be set after all Alarm values match the current time.
4	Update-Ended Flag (UF) — RO. 0 = The bit is cleared upon RSMRST# or a read of Register C. 1 = Set immediately following an update cycle for each second.
3:0	Reserved. Will always report 0.

10.6.2.4 RTC_REGD—Register D (Flag Register) (LPC I/F—D31:F0)

RTC Index:	0Dh	Attribute:	R/W
Default Value:	10UUUUUU (U: Undefined)	Size:	8-bit
Lockable:	No	Power Well:	RTC

Bit	Description
7	Valid RAM and Time Bit (VRT) — R/W. 0 = This bit should always be written as a 0 for write cycle, however it will return a 1 for read cycles. 1 = This bit is hardwired to 1 in the RTC power well.
6	Reserved. This bit always returns a 0 and should be set to 0 for write cycles.
5:0	Date Alarm — R/W. These bits store the date of month alarm value. If set to 000000b, then a don't care state is assumed. The host must configure the date alarm for these bits to do anything, yet they can be written at any time. If the date alarm is not enabled, these bits will return 0's to mimic the functionality of the Motorola 146818B. These bits are not affected by any reset assertion.

10.7 Processor Interface Registers (LPC I/F—D31:F0)

Table 10-8 is the register address map for the processor interface registers.

Table 10-8. Processor Interface PCI Register Address Map (LPC I/F—D31:F0)

Offset	Mnemonic	Register Name	Default	Type
61h	NMI_SC	NMI Status and Control	00h	R/W, RO
70h	NMI_EN	NMI Enable	80h	R/W (special)
92h	PORT92	Fast A20 and Init	00h	R/W
F0h	COPROC_ERR	Coprocessor Error	00h	WO
CF9h	RST_CNT	Reset Control	00h	R/W

10.7.1 NMI_SC—NMI Status and Control Register (LPC I/F—D31:F0)

I/O Address:	61h	Attribute:	R/W, RO
Default Value:	00h	Size:	8-bit
Lockable:	No	Power Well:	Core

Bit	Description
7	<p>SERR# NMI Source Status (SERR#_NMI_STS) — RO.</p> <p>1 = Bit is set if a PCI agent detected a system error and pulses the PCI SERR# line and if bit 2 (PCI_SERR_EN) is cleared. This interrupt source is enabled by setting bit 2 to 0. To reset the interrupt, set bit 2 to 1 and then set it to 0. When writing to port 61h, this bit must be 0.</p> <p>NOTE: This bit is set by any of the ICH6 internal sources of SERR; this includes SERR assertions forwarded from the secondary PCI bus, errors on a PCI Express* port, or other internal functions that generate SERR#.</p>
6	<p>IOCHK# NMI Source Status (IOCHK_NMI_STS) — RO.</p> <p>1 = Bit is set if an LPC agent (via SERIRQ) asserted IOCHK# and if bit 3 (IOCHK_NMI_EN) is cleared. This interrupt source is enabled by setting bit 3 to 0. To reset the interrupt, set bit 3 to 1 and then set it to 0. When writing to port 61h, this bit must be a 0.</p>
5	<p>Timer Counter 2 OUT Status (TMR2_OUT_STS) — RO. This bit reflects the current state of the 8254 counter 2 output. Counter 2 must be programmed following any PCI reset for this bit to have a determinate value. When writing to port 61h, this bit must be a 0.</p>
4	<p>Refresh Cycle Toggle (REF_TOGGLE) — RO. This signal toggles from either 0 to 1 or 1 to 0 at a rate that is equivalent to when refresh cycles would occur. When writing to port 61h, this bit must be a 0.</p>
3	<p>IOCHK# NMI Enable (IOCHK_NMI_EN) — R/W.</p> <p>0 = Enabled. 1 = Disabled and cleared.</p>
2	<p>PCI SERR# Enable (PCI_SERR_EN) — R/W.</p> <p>0 = SERR# NMIs are enabled. 1 = SERR# NMIs are disabled and cleared.</p>
1	<p>Speaker Data Enable (SPKR_DAT_EN) — R/W.</p> <p>0 = SPKR output is a 0. 1 = SPKR output is equivalent to the Counter 2 OUT signal value.</p>
0	<p>Timer Counter 2 Enable (TIM_CNT2_EN) — R/W.</p> <p>0 = Disable 1 = Enable</p>

10.7.2 NMI_EN—NMI Enable (and Real Time Clock Index) Register (LPC I/F—D31:F0)

I/O Address:	70h	Attribute:	R/W (special)
Default Value:	80h	Size:	8-bit
Lockable:	No	Power Well:	Core

Note: The RTC Index field is write-only for normal operation. This field can only be read in Alt-Access Mode. Note, however, that this register is aliased to Port 74h (documented in), and all bits are readable at that address.

Bits	Description
7	NMI Enable (NMI_EN) — R/W (special). 0 = Enable NMI sources. 1 = Disable All NMI sources.
6:0	Real Time Clock Index Address (RTC_INDX) — R/W (special). This data goes to the RTC to select which register or CMOS RAM address is being accessed.

10.7.3 PORT92—Fast A20 and Init Register (LPC I/F—D31:F0)

I/O Address:	92h	Attribute:	R/W
Default Value:	00h	Size:	8-bit
Lockable:	No	Power Well:	Core

Bit	Description
7:2	Reserved
1	Alternate A20 Gate (ALT_A20_GATE) — R/W. This bit is Or'd with the A20GATE input signal to generate A20M# to the processor. 0 = A20M# signal can potentially go active. 1 = This bit is set when INIT# goes active.
0	INIT_NOW — R/W. When this bit transitions from a 0 to a 1, the ICH6 will force INIT# active for 16 PCI clocks.

10.7.4 COPROC_ERR—Coprocessor Error Register (LPC I/F—D31:F0)

I/O Address: F0h Attribute: WO
 Default Value: 00h Size: 8-bits
 Lockable: No Power Well: Core

Bits	Description
7:0	Coprocessor Error (COPROC_ERR) — WO. Any value written to this register will cause IGNNE# to go active, if FERR# had generated an internal IRQ13. For FERR# to generate an internal IRQ13, the COPROC_ERR_EN bit (Device 31:Function 0, Offset D0, Bit 13) must be 1.

10.7.5 RST_CNT—Reset Control Register (LPC I/F—D31:F0)

I/O Address: CF9h Attribute: R/W
 Default Value: 00h Size: 8-bit
 Lockable: No Power Well: Core

Bit	Description
7:4	Reserved
3	<p>Full Reset (FULL_RST) — R/W. This bit is used to determine the states of SLP_S3#, SLP_S4#, and SLP_S5# after a CF9 hard reset (SYS_RST = 1 and RST_CPU is set to 1), after PWROK going low (with RSMRST# high), or after two TCO timeouts.</p> <p>0 = ICH6 will keep SLP_S3#, SLP_S4# and SLP_S5# high. 1 = ICH6 will drive SLP_S3#, SLP_S4# and SLP_S5# low for 3 – 5 seconds.</p> <p>NOTE: When this bit is set, it also causes the full power cycle (SLP_S3/4/5# assertion) in response to SYSRESET#, PWROK#, and Watchdog timer reset sources.</p>
2	Reset CPU (RST_CPU) — R/W. When this bit transitions from a 0 to a 1, it initiates a hard or soft reset, as determined by the SYS_RST bit (bit 1 of this register).
1	<p>System Reset (SYS_RST) — R/W. This bit is used to determine a hard or soft reset to the processor.</p> <p>0 = When RST_CPU bit goes from 0 to 1, the ICH6 performs a soft reset by activating INIT# for 16 PCI clocks. 1 = When RST_CPU bit goes from 0 to 1, the ICH6 performs a hard reset by activating PLTRST# and SUS_STAT# active for about 5-6 milliseconds, however the SLP_S3#, SLP_S4# and SLP_S5# will NOT go active. The ICH6 main power well is reset when this bit is 1. It also resets the resume well bits (except for those noted throughout the Datasheet).</p>
0	Reserved

10.8 Power Management Registers (PM—D31:F0)

The power management registers are distributed within the PCI Device 31: Function 0 space, as well as a separate I/O range. Each register is described below. Unless otherwise indicate, bits are in the main (core) power well.

Bits not explicitly defined in each register are assumed to be reserved. When writing to a reserved bit, the value should always be 0. Software should not attempt to use the value read from a reserved bit, as it may not be consistently 1 or 0.

10.8.1 Power Management PCI Configuration Registers (PM—D31:F0)

Table 10-9 shows a small part of the configuration space for PCI Device 31: Function 0. It includes only those registers dedicated for power management. Some of the registers are only used for Legacy Power management schemes.

Table 10-9. Power Management PCI Register Address Map (PM—D31:F0)

Offset	Mnemonic	Register Name	Default	Type
A0h	GEN_PMCON_1	General Power Management Configuration 1	0000h	R/W, RO, R/WO
A2h	GEN_PMCON_2	General Power Management Configuration 2	00h	R/W, R/WC
A4h	GEN_PMCON_3	General Power Management Configuration 3	00h	R/W, R/WC
A9h	Cx-STATE_CNF	Cx State Configuration (Mobile Only).	00h	R/W
AAh	C4-TIMING_CNT	C4 Timing Control (Mobile Only).	00h	R/W
ABh	BM_BREAK_EN	BM_BREAK_EN	00h	R/W
ADh	MSC_FUN	Miscellaneous Functionality	00h	R/W
B8–BBh	GPI_ROUT	GPI Route Control	00000000h	R/W

10.8.1.1 GEN_PMCON_1—General PM Configuration 1 Register (PM—D31:F0)

Offset Address:	A0h	Attribute:	R/W, RO, R/WO
Default Value:	0000h	Size:	16-bit
Lockable:	No	Usage:	ACPI, Legacy
		Power Well:	Core

Bit	Description
15:11	Reserved
10	BIOS_PCI_EXP_EN — R/W. This bit acts as a global enable for the SCI associated with the PCI Express* ports. 0 = The various PCI Express ports and (G)MCH cannot cause the PCI_EXP_STS bit to go active. 1 = The various PCI Express ports and (G)MCH can cause the PCI_EXP_STS bit to go active.
9	PWRBTN_LVL — RO. This bit indicates the current state of the PWRBTN# signal. 0 = Low. 1 = High.
8	Reserved
7 (Desktop Only)	Reserved
7 (Mobile Only)	Enter C4 When C3 Invoked (C4onC3_EN) — R/W. If this bit is set, then when software does a LVL3 read, the ICH6 transitions to the C4 state.
6	i64_EN . Software sets this bit to indicate that the processor is an IA_64 processor, not an IA_32 processor. This may be used in various state machines where there are behavioral differences.
5	CPU SLP# Enable (CPUSLP_EN) — R/W. 0 = Disable. 1 = Enables the CPUSLP# signal to go active in the S1 state. This reduces the processor power. NOTE: CPUSLP# will go active during Intel SpeedStep® technology transitions and on entry to C3 and C4 states even if this bit is not set.
4	SMI_LOCK — R/WO. When this bit is set, writes to the GLB_SMI_EN bit (PMBASE + 30h, bit 0) will have no effect. Once the SMI_LOCK bit is set, writes of 0 to SMI_LOCK bit will have no effect (i.e., once set, this bit can only be cleared by PLTRST#).
3:2 (Desktop Only)	Reserved
3 (Mobile Only)	Intel SpeedStep Enable (SS_EN) — R/W. 0 = Intel SpeedStep technology logic is disabled and the SS_CNT register will not be visible (reads to SS_CNT will return 00h and writes will have no effect). 1 = Intel SpeedStep technology logic is enabled.
2 (Mobile Only)	PCI CLKRUN# Enable (CLKRUN_EN) — R/W. 0 = Disable. ICH6 drives the CLKRUN# signal low. 1 = Enable CLKRUN# logic to control the system PCI clock via the CLKRUN# and STP_PCI# signals. NOTE: when the SLP_EN# bit is set, the ICH6 drives the CLKRUN# signal low regardless of the state of the CLKRUN_EN bit. This ensures that the PCI and LPC clocks continue running during a transition to a sleep state.
1:0	Periodic SMI# Rate Select (PER_SMI_SEL) — R/W. Set by software to control the rate at which periodic SMI# is generated. 00 = 1 minute 01 = 32 seconds 10 = 16 seconds 11 = 8 seconds

10.8.1.2 GEN_PMCON_2—General PM Configuration 2 Register (PM—D31:F0)

Offset Address:	A2h	Attribute:	R/W, R/WC
Default Value:	00h	Size:	8-bit
Lockable:	No	Usage:	ACPI, Legacy
		Power Well:	Resume

Bit	Description
7	<p>DRAM Initialization Bit — R/W. This bit does not effect hardware functionality in any way. BIOS is expected to set this bit prior to starting the DRAM initialization sequence and to clear this bit after completing the DRAM initialization sequence. BIOS can detect that a DRAM initialization sequence was interrupted by a reset by reading this bit during the boot sequence.</p> <ul style="list-style-type: none"> If the bit is 1, then the DRAM initialization was interrupted. This bit is reset by the assertion of the RSMRST# pin.
6:5	<p>CPU PLL Lock Time (CPLT) — R/W. This field indicates the amount of time that the processor needs to lock its PLLs. This is used wherever timing t270 (Chapter 22) applies.</p> <p>00 = min 30.7 μs (Default) 01 = min 61.4 μs 10 = min 122.8 μs 11 = min 245.6 μs</p> <p>It is the responsibility of the BIOS to program the correct value in this field prior to the first transition to C3 or C4 states (or performing Intel SpeedStep® technology transitions).</p> <p>NOTE: The new DPSTP-TO-SLP bits (D31:F0:AAh, bits 1:0) act as an override to these bits. NOTE: These bits are not cleared by any type of reset except RSMRST# or a CF9 write</p>
4	<p>System Reset Status (SRS) — R/WC. Software clears this bit by writing a 1 to it.</p> <p>0 = SYS_RESET# button Not pressed. 1 = ICH6 sets this bit when the SYS_RESET# button is pressed. BIOS is expected to read this bit and clear it, if it is set.</p> <p>NOTE: This bit is also reset by RSMRST# and CF9h resets.</p>
3	<p>CPU Thermal Trip Status (CTS) — R/WC.</p> <p>0 = Software clears this bit by writing a 1 to it. 1 = This bit is set when PLTRST# is inactive and THRMTRIP# goes active while the system is in an S0 or S1 state.</p> <p>NOTES:</p> <ol style="list-style-type: none"> This bit is also reset by RSMRST#, and CF9h resets. It is not reset by the shutdown and reboot associated with the CPUTHRMTRIP# event. The CF9h reset in the description refers to CF9h type core well reset which includes SYS_RST#, PWROK/VRMPWRGD low, SMBus hard reset, TCO Timeout. This type of reset will clear CTS bit.

Bit	Description
2	<p>Minimum SLP_S4# Assertion Width Violation Status — R/WC.</p> <p>0 = Software clears this bit by writing a 1 to it. 1 = Hardware sets this bit when the SLP_S4# assertion width is less than the time programmed in the SLP_S4# Minimum Assertion Width field (D31:F0:Offset A4h:bits 5:4). The ICH6 begins the timer when SLP_S4# is asserted during S4/S5 entry, or when the RSMRST# input is deasserted during G3 exit. Note that this bit is functional regardless of the value in the SLP_S4# Assertion Stretch Enable (D31:F0:Offset A4h:bit 3).</p> <p>NOTE: This bit is reset by the assertion of the RSMRST# pin, but can be set in some cases before the default value is readable.</p>
1	<p>CPU Power Failure (CPUPWR_FLR) — R/WC.</p> <p>0 = Software (typically BIOS) clears this bit by writing a 0 to it. 1 = Indicates that the VRMPWRGD signal from the processor's VRM went low while the system was in an S0 or S1 state.</p>
0	<p>PWROK Failure (PWROK_FLR) — R/WC.</p> <p>0 = Software clears this bit by writing a 1 to it, or when the system goes into a G3 state. 1 = This bit will be set any time PWROK goes low, when the system was in S0, or S1 state. The bit will be cleared only by software by writing a 1 to this bit or when the system goes to a G3 state.</p> <p>NOTE: See Chapter 5.14.11.3 for more details about the PWROK pin functionality. NOTE: In the case of true PWROK failure, PWROK will go low first before the VRMPWRGD.</p>

NOTE: VRMPWROK is sampled using the RTC clock. Therefore, low times that are less than one RTC clock period may not be detected by the ICH6.

10.8.1.3 GEN_PMCON_3—General PM Configuration 3 Register (PM—D31:F0)

Offset Address:	A4h	Attribute:	R/W, R/WC
Default Value:	00h	Size:	8-bit
Lockable:	No	Usage:	ACPI, Legacy
		Power Well:	RTC

Bit	Description
7:6	<p>SWSMI_RATE_SEL — R/W. This field indicates when the SWSMI timer will time out. Valid values are:</p> <p>00 = 1.5 ms ± 0.6 ms 01 = 16 ms ± 4 ms 10 = 32 ms ± 4 ms 11 = 64 ms ± 4 ms</p> <p>These bits are not cleared by any type of reset except RTCRST#.</p>
5:4	<p>SLP_S4# Minimum Assertion Width — R/W. This field indicates the minimum assertion width of the SLP_S4# signal to guarantee that the DRAMs have been safely power-cycled. Valid values are:</p> <p>11 = 1 to 2 seconds 10 = 2 to 3 seconds 01 = 3 to 4 seconds 00 = 4 to 5 seconds</p> <p>This value is used in two ways:</p> <ol style="list-style-type: none"> 1. If the SLP_S4# assertion width is ever shorter than this time, a status bit is set for BIOS to read when S0 is entered. 2. If enabled by bit 3 in this register, the hardware will prevent the SLP_S4# signal from de-asserting within this minimum time period after asserting. <p>RTCRST# forces this field to the conservative default state (00b)</p>
3	<p>SLP_S4# Assertion Stretch Enable — R/W.</p> <p>0 = The SLP_S4# minimum assertion time is 1 to 2 RTCCLK. 1 = The SLP_S4# signal minimally assert for the time specified in bits 5:4 of this register.</p> <p>This bit is cleared by RTCRST#</p>
2	<p>RTC Power Status (RTC_PWR_STS) — R/W. This bit is set when RTCRST# indicates a weak or missing battery. The bit is not cleared by any type of reset. The bit will remain set until the software clears it by writing a 0 back to this bit position.</p>
1	<p>Power Failure (PWR_FLR) — R/WC. This bit is in the RTC well, and is not cleared by any type of reset except RTCRST#.</p> <p>0 = Indicates that the trickle current has not failed since the last time the bit was cleared. Software clears this bit by writing a 1 to it. 1 = Indicates that the trickle current (from the main battery or trickle supply) was removed or failed.</p> <p>NOTE: Clearing CMOS in an ICH-based platform can be done by using a jumper on RTCRST# or GPI, or using SAFEMODE strap. Implementations should not attempt to clear CMOS by using a jumper to pull VccRTC low.</p>
0	<p>AFTERG3_EN — R/W. This bit determines what state to go to when power is re-applied after a power failure (G3 state). This bit is in the RTC well and is not cleared by any type of reset except writes to CF9h or RTCRST#.</p> <p>0 = System will return to S0 state (boot) after power is re-applied. 1 = System will return to the S5 state (except if it was in S4, in which case it will return to S4). In the S5 state, the only enabled wake event is the Power Button or any enabled wake event that was preserved through the power failure.</p> <p>NOTE: Bit will be set when THRMTRIP#-based shutdown occurs.</p>

NOTE: RSMRST# is sampled using the RTC clock. Therefore, low times that are less than one RTC clock period may not be detected by the ICH6.

10.8.1.4 Cx-STATE_CNF—Cx State Configuration Register (PM—D31:F0) (Mobile Only)

Offset Address:	A9h	Attribute:	R/W
Default Value:	00h	Size:	8-bit
Lockable:	No	Usage:	ACPI, Legacy
Power Well:	Core		

This register is used to enable new C-state related modes.

Bit	Description
7	SCRATCHPAD (SP) — R/W.
6:5	Reserved
4	<p>Popdown Mode Enable (PDME) — R/W. This bit is used in conjunction with the PUME bit (D31:F0:A9h, bit 3). If PUME is 0, then this bit must also be 0.</p> <p>0 = The ICH6 will not attempt to automatically return to a previous C3 or C4 state. 1 = When this bit is a 1 and Intel® ICH6 observes that there are no bus master requests, it can return to a previous C3 or C4 state.</p> <p>NOTE: This bit is separate from the PUME bit to cover cases where latency issues permit POPUP but not POPDOWN.</p>
3	<p>Popup Mode Enable (PUME) — R/W. When this bit is a 0, the ICH6 behaves like ICH5, in that bus master traffic is a break event, and it will return from C3/C4 to C0 based on a break event. See Chapter 5.14.5 for additional details on this mode.</p> <p>0 = The ICH6 will treat Bus master traffic a break event, and will return from C3/C4 to C0 based on a break event. 1 = When this bit is a 1 and ICH6 observes a bus master request, it will take the system from a C3 or C4 state to a C2 state and auto enable bus masters. This will let snoops and memory access occur.</p>
2	<p>Report Zero for BM_STS (BM_STS_ZERO_EN) — R/W.</p> <p>0 = The ICH6 sets BM_STS (PMBASE + 00h, bit 4) if there is bus master activity from PCI, PCI Express* and internal bus masters. 1 = When this bit is a 1, ICH6 will not set the BM_STS if there is bus master activity from PCI, PCI Express and internal bus masters.</p> <p>NOTES:</p> <ol style="list-style-type: none"> 1. If the BM_STS bit is already set when the BM_STS_ZERO_EN bit is set, the BM_STS bit will remain set. Software will still need to clear the BM_STS bit. 2. It is expected that if the PUME bit (this register, bit 3) is set, the BM_STS_ZERO_EN bit should also be set. Setting one without the other would mainly be for debug or errata workaround. 3. BM_STS will be set by LPC DMA or LPC masters, even if BM_STS_ZERO_EN is set.
1:0	Reserved

10.8.1.5 C4-TIMING_CNT—C4 Timing Control Register (PM—D31:F0) (Mobile Only)

Offset Address:	AAh	Attribute:	R/W
Default Value:	00h	Size:	8-bit
Lockable:	No	Usage:	ACPI, Legacy
Power Well:	Core		

This register is used to enable C-state related modes.

Bit	Description																				
7:4	Reserved																				
3:2	<p>DPRSLPVR to STPCPU — R/W. This field selects the amount of time that the ICH6 waits for from the de-assertion of DPRSLPVR to the de-assertion of STP_CPU#. This provides a programmable time for the processor’s voltage to stabilize when exiting from a C4 state. This thus changes the value for t266.</p> <table border="1"> <thead> <tr> <th>Bits</th> <th>t266_{min}</th> <th>t266_{max}</th> <th>Comment</th> </tr> </thead> <tbody> <tr> <td>00b</td> <td>95 μs</td> <td>101 μs</td> <td>Default</td> </tr> <tr> <td>01b</td> <td>22 μs</td> <td>28 μs</td> <td>Value used for “Fast” VRMs</td> </tr> <tr> <td>10b</td> <td></td> <td></td> <td>Reserved</td> </tr> <tr> <td>11b</td> <td></td> <td></td> <td>Reserved</td> </tr> </tbody> </table>	Bits	t266 _{min}	t266 _{max}	Comment	00b	95 μs	101 μs	Default	01b	22 μs	28 μs	Value used for “Fast” VRMs	10b			Reserved	11b			Reserved
Bits	t266 _{min}	t266 _{max}	Comment																		
00b	95 μs	101 μs	Default																		
01b	22 μs	28 μs	Value used for “Fast” VRMs																		
10b			Reserved																		
11b			Reserved																		
1:0	<p>DPSLP-TO-SLP — R/W. This field selects the DPSLP# de-assertion to CPU_SLP# de-assertion time (t270). Normally this value is determined by the CPU_PLL_LOCK_TIME field in the GEN_PMCON_2 register. When this field is non-zero, then the values in this register have higher priority. It is software’s responsibility to program these fields in a consistent manner.</p> <table border="1"> <thead> <tr> <th>Bits</th> <th>t270</th> </tr> </thead> <tbody> <tr> <td>00b</td> <td>Use value is CPU_PLL_LOCK_TIME field (default is 30 μs)</td> </tr> <tr> <td>01b</td> <td>20 μs</td> </tr> <tr> <td>10b</td> <td>15 μs</td> </tr> <tr> <td>11b</td> <td>10 μs</td> </tr> </tbody> </table>	Bits	t270	00b	Use value is CPU_PLL_LOCK_TIME field (default is 30 μs)	01b	20 μs	10b	15 μs	11b	10 μs										
Bits	t270																				
00b	Use value is CPU_PLL_LOCK_TIME field (default is 30 μs)																				
01b	20 μs																				
10b	15 μs																				
11b	10 μs																				

10.8.1.6 BM_BREAK_EN Register (PM—D31:F0) (Mobile Only)

Offset Address:	ABh	Attribute:	R/W
Default Value:	00h	Size:	8-bit
Lockable:	No	Usage:	ACPI, Legacy
Power Well:	Core		

Bit	Description
7	IDE_BREAK_EN — R/W. 0 = Parallel IDE or Serial ATA traffic will not act as a break event. 1 = Parallel IDE or Serial ATA traffic acts as a break event, even if the BM_STS-ZERO_EN and POPUP_EN bits are set. Parallel IDE or Serial ATA master activity will cause BM_STS to be set and will cause a break from C3/C4.
6	PCIE_BREAK_EN — R/W. 0 = PCI Express* traffic will not act as a break event. 1 = PCI Express traffic acts as a break event, even if the BM_STS-ZERO_EN and POPUP_EN bits are set. PCI Express master activity will cause BM_STS to be set and will cause a break from C3/C4.
5	PCI_BREAK_EN — R/W. 0 = PCI traffic will not act as a break event. 1 = PCI traffic acts as a break event, even if the BM_STS-ZERO_EN and POPUP_EN bits are set. PCI master activity will cause BM_STS to be set and will cause a break from C3/C4.
4:3	Reserved
2	EHCI_BREAK_EN — R/W. 0 = EHCI traffic will not act as a break event. 1 = EHCI traffic acts as a break event, even if the BM_STS-ZERO_EN and POPUP_EN bits are set. EHCI master activity will cause BM_STS to be set and will cause a break from C3/C4.
1	UHCI_BREAK_EN — R/W. 0 = UHCI traffic will not act as a break event. 1 = USB traffic from any of the internal UHCIs acts as a break event, even if the BM_STS-ZERO_EN and POPUP_EN bits are set. UHCI master activity will cause BM_STS to be set and will cause a break from C3/C4.
0	ACAZ_BREAK_EN — R/W. 0 = AC '97 or Intel High Definition Audio traffic will not act as a break event. 1 = AC '97 or Intel High Definition Audio traffic acts as a break event, even if the BM_STS-ZERO_EN and POPUP_EN bits are set. AC '97 or Intel High Definition Audio master activity will cause BM_STS to be set and will cause a break from C3/C4.

10.8.1.7 MSC_FUN—Miscellaneous Functionality Register (PM—D31:F0)

Offset Address: ADh Attribute: R/W
 Default Value: 00h Size: 8-bit
 Power Well: Resume

Bit	Description
7:6	Reserved
5	LPC Generic Range 2 Bit 5 Mask (LGR5M) — R/W. 0 = The existing LPC Generic I/O decode range 2 decodes bit 5 as defined in the D31:F0h:88h register description. 1 = The LPC Generic I/O decode range 2 forces an address match on bit 5. NOTE: If this bit is set, LGR4M (bit 4 of this register) must also be set.
4	LPC Generic Range 2 Bit 4 Mask (LGR4M) — R/W. 0 = The existing LPC Generic I/O decode range 2 decodes bit 4 as defined in the D31:F0h:88h register description. 1 = The LPC Generic I/O decode range 2 forces an address match on bit 4.
3	Reserved
2	Top Swap Status (TSS) — RO. This bit provides a read-only path to view the state of the Top Swap bit that is in the Chipset Configuration Registers:Offset 3414h:bit 0.
1:0	USB Transient Disconnect Detect (TDD) — R/W: This field prevents a short Single-Ended Zero (SE0) condition on the USB ports from being interpreted by the UHCI host controller as a disconnect. BIOS should set to 11b.

10.8.1.8 GPI_ROUT—GPI Routing Control Register (PM—D31:F0)

Offset Address: B8h – BBh Attribute: R/W
 Default Value: 00000000h Size: 32-bit
 Lockable: No Power Well: Resume

Bit	Description
31:30	GPI15 Route — R/W. See bits 1:0 for description.
Same pattern for GPI14 through GPI3	
5:4	GPI2 Route — R/W. See bits 1:0 for description.
3:2	GPI1 Route — R/W. See bits 1:0 for description.
1:0	GPI0 Route — R/W. GPI[15:0] can be routed to cause an SMI or SCI when the GPI[n]_STS bit is set. If the GPIO is not set to an input, this field has no effect. If the system is in an S1–S5 state and if the GPE0_EN bit is also set, then the GPI can cause a Wake event, even if the GPI is NOT routed to cause an SMI# or SCI. 00 = No effect. 01 = SMI# (if corresponding ALT_GPI_SMI_EN bit is also set) 10 = SCI (if corresponding GPE0_EN bit is also set) 11 = Reserved Software must set this bit field to generate the appropriate type of system interrupt, depending on how the SCI_EN bit is set. For example, if the SCI_EN bit is set, then this field must be programmed to 00b or 10b. If the SCI_EN bit is cleared, then this field must be programmed to 00b or 01b. Software must also update this field if the SCI_EN bit is changed.

Note: GPIOs that are not implemented will not have the corresponding bits implemented in this register.

10.8.2 APM I/O Decode

Table 10-10 shows the I/O registers associated with APM support. This register space is enabled in the PCI Device 31: Function 0 space (APMDEC_EN), and cannot be moved (fixed I/O location).

Table 10-10. APM Register Map

Address	Mnemonic	Register Name	Default	Type
B2h	APM_CNT	Advanced Power Management Control Port	00h	R/W
B3h	APM_STS	Advanced Power Management Status Port	00h	R/W

10.8.2.1 APM_CNT—Advanced Power Management Control Port Register

I/O Address:	B2h	Attribute:	R/W
Default Value:	00h	Size:	8-bit
Lockable:	No	Usage:	Legacy Only
Power Well:	Core		

Bit	Description
7:0	This field is used to pass an APM command between the OS and the SMI handler. Writes to this port not only store data in the APMC register, but also generates an SMI# when the APMC_EN bit is set.

10.8.2.2 APM_STS—Advanced Power Management Status Port Register

I/O Address:	B3h	Attribute:	R/W
Default Value:	00h	Size:	8-bit
Lockable:	No	Usage:	Legacy Only
Power Well:	Core		

Bit	Description
7:0	This field is used to pass data between the OS and the SMI handler. Basically, this is a scratchpad register and is not affected by any other register or function (other than a PCI reset).

10.8.3 Power Management I/O Registers

Table 10-11 shows the registers associated with ACPI and Legacy power management support. These registers are enabled in the PCI Device 31: Function 0 space (PM_IO_EN), and can be moved to any I/O location (128-byte aligned). The registers are defined to be compliant with the ACPI 2.0 specification, and use the same bit names.

Note: All reserved bits and registers will always return 0 when read, and will have no effect when written.

Table 10-11. ACPI and Legacy I/O Register Map

PMBASE + Offset	Mnemonic	Register Name	ACPI Pointer	Default	Type
00–01h	PM1_STS	PM1 Status	PM1a_EVT_BLK	0000h	R/WC
02–03h	PM1_EN	PM1 Enable	PM1a_EVT_BLK+2	0000h	R/W
04–07h	PM1_CNT	PM1 Control	PM1a_CNT_BLK	00000000h	R/W, WO
08–0Bh	PM1_TMR	PM1 Timer	PMTMR_BLK	xx000000h	RO
0C–0Fh	—	Reserved	—	—	—
10h–13h	PROC_CNT	Processor Control	P_BLK	00000000h	R/W, RO, WO
14h	LV2	Level 2	P_BLK+4	00h	RO
15h–16h	—	Reserved (Desktop Only)	—	—	—
15h	LV3	Level 3 (Mobile Only)	P_BLK+5	00h	RO
16h	LV4	Level 4 (Mobile Only)	P_BLK+6	00h	RO
17–1Fh	—	Reserved	—	—	—
20h	—	Reserved (Desktop Only)	—	—	—
20h	PM2_CNT	PM2 Control (Mobile Only)	PM2a_CNT_BLK	00h	R/W
28–2Bh	GPE0_STS	General Purpose Event 0 Status	GPE0_BLK	00000000h	R/W, R/WC
2C–2Fh	GPE0_EN	General Purpose Event 0 Enables	GPE0_BLK+4	00000000h	R/W
30–33h	SMI_EN	SMI# Control and Enable		00000000h	R/W, WO, R/W (special)
34–37h	SMI_STS	SMI Status		00000000h	R/WC, RO
38–39h	ALT_GP_SMI_EN	Alternate GPI SMI Enable		0000h	R/W
3A–3Bh	ALT_GP_SMI_STS	Alternate GPI SMI Status		0000h	R/WC
3C–43h	—	Reserved	—	—	—
44–45h	DEVACT_STS	Device Activity Status		0000h	R/WC
46h–4Fh	—	Reserved			
50h	—	Reserved (Desktop Only)			
50h	SS_CNT	Intel SpeedStep® Technology Control (Mobile Only)		01h	R/W (special)
51h–5Fh	—	Reserved	—	—	—
54h–57h	C3_RES (Mobile Only)	C3-Residency Register	—	00000000h	RO, R/W
60h–7Fh	—	Reserved for TCO	—	—	—

10.8.3.1 PM1_STS—Power Management 1 Status Register

I/O Address:	PMBASE + 00h (ACPI PM1a_EVT_BLK)	Attribute:	R/WC
Default Value:	0000h	Size:	16-bit
Lockable:	No	Usage:	ACPI or Legacy
Power Well:	Bits 0–7: Core, Bits 8–15: Resume, except Bit 11 in RTC		

If bit 10 or 8 in this register is set, and the corresponding _EN bit is set in the PM1_EN register, then the ICH6 will generate a Wake Event. Once back in an S0 state (or if already in an S0 state when the event occurs), the ICH6 will also generate an SCI if the SCI_EN bit is set, or an SMI# if the SCI_EN bit is not set.

Note: Bit 5 does not cause an SMI# or a wake event. Bit 0 does not cause a wake event but can cause an SMI# or SCI.

Bit	Description
15	<p>Wake Status (WAK_STS) — R/WC. This bit is not affected by hard resets caused by a CF9 write, but is reset by RSMRST#.</p> <p>0 = Software clears this bit by writing a 1 to it. 1 = Set by hardware when the system is in one of the sleep states (via the SLP_EN bit) and an enabled wake event occurs. Upon setting this bit, the ICH6 will transition the system to the ON state.</p> <p>If the AFTERG3_EN bit is not set and a power failure (such as removed batteries) occurs without the SLP_EN bit set, the system will return to an S0 state when power returns, and the WAK_STS bit will not be set.</p> <p>If the AFTERG3_EN bit is set and a power failure occurs without the SLP_EN bit having been set, the system will go into an S5 state when power returns, and a subsequent wake event will cause the WAK_STS bit to be set. Note that any subsequent wake event would have to be caused by either a Power Button press, or an enabled wake event that was preserved through the power failure (enable bit in the RTC well).</p>
14	Reserved
13:12	Reserved
11	<p>Power Button Override Status (PRBTNOR_STS) — R/WC.</p> <p>0 = Software clears this bit by writing a 1 to it. 1 = This bit is set any time a Power Button Override occurs (i.e., the power button is pressed for at least 4 consecutive seconds), or due to the corresponding bit in the SMBus slave message. The power button override causes an unconditional transition to the S5 state, as well as sets the AFTERG# bit. The BIOS or SCI handler clears this bit by writing a 1 to it. This bit is not affected by hard resets via CF9h writes, and is not reset by RSMRST#. Thus, this bit is preserved through power failures. Note that if this bit is still asserted when the global SCI_EN is set then an SCI will be generated.</p>
10	<p>RTC Status (RTC_STS) — R/WC. This bit is not affected by hard resets caused by a CF9 write, but is reset by RSMRST#.</p> <p>0 = Software clears this bit by writing a 1 to it. 1 = Set by hardware when the RTC generates an alarm (assertion of the IRQ8# signal). Additionally if the RTC_EN bit (PMBASE + 02h, bit 10) is set, the setting of the RTC_STS bit will generate a wake event.</p>
9	Reserved

Bit	Description
8	<p>Power Button Status (PWRBTN_STS) — R/WC. This bit is not affected by hard resets caused by a CF9 write.</p> <p>0 = If the PWRBTN# signal is held low for more than 4 seconds, the hardware clears the PWRBTN_STS bit, sets the PWRBTNOR_STS bit, and the system transitions to the S5 state with only PWRBTN# enabled as a wake event.</p> <p>This bit can be cleared by software by writing a one to the bit position.</p> <p>1 = This bit is set by hardware when the PWRBTN# signal is asserted Low, independent of any other enable bit.</p> <p>In the S0 state, while PWRBTN_EN and PWRBTN_STS are both set, an SCI (or SMI# if SCI_EN is not set) will be generated.</p> <p>In any sleeping state S1–S5, while PWRBTN_EN (PMBASE + 02h, bit 8) and PWRBTN_STS are both set, a wake event is generated.</p> <p>NOTE: If the PWRBTN_STS bit is cleared by software while the PWRBTN# signal is still asserted, this will not cause the PWRBTN_STS bit to be set. The PWRBTN# signal must go inactive and active again to set the PWRBTN_STS bit.</p>
7:6	Reserved
5	<p>Global Status (GBL_STS) — R/WC.</p> <p>0 = The SCI handler should then clear this bit by writing a 1 to the bit location.</p> <p>1 = Set when an SCI is generated due to BIOS wanting the attention of the SCI handler. BIOS has a corresponding bit, BIOS_RLS, which will cause an SCI and set this bit.</p>
4 (Desktop Only)	Reserved
4 (Mobile Only)	<p>Bus Master Status (BM_STS) — R/WC. This bit will not cause a wake event, SCI or SMI#.</p> <p>0 = Software clears this bit by writing a 1 to it.</p> <p>1 = Set by the ICH6 when a bus master requests access to main memory. Bus master activity is detected by any of the PCI Requests being active, any internal bus master request being active, the BMBUSY# signal being active, or REQ-C2 message received while in C3 or C4 state.</p> <p>NOTES:</p> <p>1. If the BM_STS_ZERO_EN bit is set, then this bit will generally report as a 0. LPC DMA and bus master activity will always set the BM_STS bit, even if the BM_STS_ZERO_EN bit is set.</p>
3:1	Reserved
0	<p>Timer Overflow Status (TMROF_STS) — R/WC.</p> <p>0 = The SCI or SMI# handler clears this bit by writing a 1 to the bit location.</p> <p>1 = This bit gets set any time bit 22 of the 24-bit timer goes high (bits are numbered from 0 to 23). This will occur every 2.3435 seconds. When the TMROF_EN bit (PMBASE + 02h, bit 0) is set, then the setting of the TMROF_STS bit will additionally generate an SCI or SMI# (depending on the SCI_EN).</p>

10.8.3.2 PM1_EN—Power Management 1 Enable Register

I/O Address: PMBASE + 02h
 (ACPI PM1a_EVT_BLK + 2) Attribute: R/W
 Default Value: 0000h Size: 16-bit
 Lockable: No Usage: ACPI or Legacy
 Power Well: Bits 0–7: Core,
 Bits 8–9, 11–15: Resume,
 Bit 10: RTC

Bit	Description												
15	Reserved												
14	Reserved												
13:11	Reserved												
10	<p>RTC Event Enable (RTC_EN) — R/W. This bit is in the RTC well to allow an RTC event to wake after a power failure. This bit is not cleared by any reset other than RTCRST# or a Power Button Override event.</p> <p>0 = No SCI (or SMI#) or wake event is generated then RTC_STS (PMBASE + 00h, bit 10) goes active. 1 = An SCI (or SMI#) or wake event will occur when this bit is set and the RTC_STS bit goes active.</p>												
9	Reserved.												
8	<p>Power Button Enable (PWRBTN_EN) — R/W. This bit is used to enable the setting of the PWRBTN_STS bit to generate a power management event (SMI#, SCI). PWRBTN_EN has no effect on the PWRBTN_STS bit (PMBASE + 00h, bit 8) being set by the assertion of the power button. The Power Button is always enabled as a Wake event.</p> <p>0 = Disable. 1 = Enable.</p>												
7:6	Reserved.												
5	<p>Global Enable (GBL_EN) — R/W. When both the GBL_EN and the GBL_STS bit (PMBASE + 00h, bit 5) are set, an SCI is raised.</p> <p>0 = Disable. 1 = Enable SCI on GBL_STS going active.</p>												
4:1	Reserved.												
0	<p>Timer Overflow Interrupt Enable (TMROF_EN) — R/W. Works in conjunction with the SCI_EN bit (PMBASE + 04h, bit 0) as described below:</p> <table border="1"> <thead> <tr> <th>TMROF_EN</th> <th>SCI_EN</th> <th>Effect when TMROF_STS is set</th> </tr> </thead> <tbody> <tr> <td>0</td> <td>X</td> <td>No SMI# or SCI</td> </tr> <tr> <td>1</td> <td>0</td> <td>SMI#</td> </tr> <tr> <td>1</td> <td>1</td> <td>SCI</td> </tr> </tbody> </table>	TMROF_EN	SCI_EN	Effect when TMROF_STS is set	0	X	No SMI# or SCI	1	0	SMI#	1	1	SCI
TMROF_EN	SCI_EN	Effect when TMROF_STS is set											
0	X	No SMI# or SCI											
1	0	SMI#											
1	1	SCI											

10.8.3.3 PM1_CNT—Power Management 1 Control

I/O Address:	PMBASE + 04h (ACPI PM1a_CNT_BLK)	Attribute:	R/W, WO
Default Value:	00000000h	Size:	32-bit
Lockable:	No	Usage:	ACPI or Legacy
Power Well:	Bits 0–7: Core, Bits 8–12: RTC, Bits 13–15: Resume		

Bit	Description																		
31:14	Reserved.																		
13	Sleep Enable (SLP_EN) — WO. Setting this bit causes the system to sequence into the Sleep state defined by the SLP_TYP field.																		
12:10	<p>Sleep Type (SLP_TYP) — R/W. This 3-bit field defines the type of Sleep the system should enter when the SLP_EN bit is set to 1. These bits are only reset by RTCRST#.</p> <table border="0"> <thead> <tr> <th>Code</th> <th>Master Interrupt</th> </tr> </thead> <tbody> <tr> <td>000b</td> <td>ON: Typically maps to S0 state.</td> </tr> <tr> <td>001b</td> <td>Asserts STPCLK#. Puts processor in Stop-Grant state. Optional to assert CPUSLP# to put processor in sleep state: Typically maps to S1 state.</td> </tr> <tr> <td>010b</td> <td>Reserved</td> </tr> <tr> <td>011b</td> <td>Reserved</td> </tr> <tr> <td>100b</td> <td>Reserved</td> </tr> <tr> <td>101b</td> <td>Suspend-To-RAM. Assert SLP_S3#: Typically maps to S3 state.</td> </tr> <tr> <td>110b</td> <td>Suspend-To-Disk. Assert SLP_S3#, and SLP_S4#: Typically maps to S4 state.</td> </tr> <tr> <td>111b</td> <td>Soft Off. Assert SLP_S3#, SLP_S4#, and SLP_S5#: Typically maps to S5 state.</td> </tr> </tbody> </table>	Code	Master Interrupt	000b	ON: Typically maps to S0 state.	001b	Asserts STPCLK#. Puts processor in Stop-Grant state. Optional to assert CPUSLP# to put processor in sleep state: Typically maps to S1 state.	010b	Reserved	011b	Reserved	100b	Reserved	101b	Suspend-To-RAM. Assert SLP_S3#: Typically maps to S3 state.	110b	Suspend-To-Disk. Assert SLP_S3#, and SLP_S4#: Typically maps to S4 state.	111b	Soft Off. Assert SLP_S3#, SLP_S4#, and SLP_S5#: Typically maps to S5 state.
Code	Master Interrupt																		
000b	ON: Typically maps to S0 state.																		
001b	Asserts STPCLK#. Puts processor in Stop-Grant state. Optional to assert CPUSLP# to put processor in sleep state: Typically maps to S1 state.																		
010b	Reserved																		
011b	Reserved																		
100b	Reserved																		
101b	Suspend-To-RAM. Assert SLP_S3#: Typically maps to S3 state.																		
110b	Suspend-To-Disk. Assert SLP_S3#, and SLP_S4#: Typically maps to S4 state.																		
111b	Soft Off. Assert SLP_S3#, SLP_S4#, and SLP_S5#: Typically maps to S5 state.																		
9:3	Reserved.																		
2	<p>Global Release (GBL_RLS) — WO.</p> <p>0 = This bit always reads as 0. 1 = ACPI software writes a 1 to this bit to raise an event to the BIOS. BIOS software has a corresponding enable and status bits to control its ability to receive ACPI events.</p>																		
1 (Desktop Only)	Reserved																		
1 (Mobile Only)	<p>Bus Master Reload (BM_RLD) — R/W. This bit is treated as a scratchpad bit. This bit is reset to 0 by PLTRST#</p> <p>0 = Bus master requests will not cause a break from the C3 state. 1 = Enable Bus Master requests (internal, external or BMBUSY#) to cause a break from the C3 state.</p> <p>If software fails to set this bit before going to C3 state, ICH6 will still return to a snoopable state from C3 or C4 states due to bus master activity.</p>																		
0	<p>SCI Enable (SCI_EN) — R/W. Selects the SCI interrupt or the SMI# interrupt for various events including the bits in the PM1_STS register (bit 10, 8, 0), and bits in GPE0_STS.</p> <p>0 = These events will generate an SMI#. 1 = These events will generate an SCI.</p>																		

10.8.3.4 PM1_TMR—Power Management 1 Timer Register

I/O Address:	PMBASE + 08h (ACPI PMTMR_BLK)	Attribute:	RO
Default Value:	xx000000h	Size:	32-bit
Lockable:	No	Usage:	ACPI
Power Well:	Core		

Bit	Description
31:24	Reserved
23:0	<p>Timer Value (TMR_VAL) — RO. Returns the running count of the PM timer. This counter runs off a 3.579545 MHz clock (14.31818 MHz divided by 4). It is reset to 0 during a PCI reset, and then continues counting as long as the system is in the S0 state. After an S1 state, the counter will not be reset (it will continue counting from the last value in S0 state).</p> <p>Anytime bit 22 of the timer goes HIGH to LOW (bits referenced from 0 to 23), the TMROF_STS bit (PMBASE + 00h, bit 0) is set. The High-to-Low transition will occur every 2.3435 seconds. If the TMROF_EN bit (PMBASE + 02h, bit 0) is set, an SCI interrupt is also generated.</p>

10.8.3.5 PROC_CNT—Processor Control Register

I/O Address:	PMBASE + 10h (ACPI P_BLK)	Attribute:	R/W, RO, WO
Default Value:	00000000h	Size:	32-bit
Lockable:	No (bits 7:5 are write once)	Usage:	ACPI or Legacy
Power Well:	Core		

Bit	Description
31:18	Reserved
17	<p>Throttle Status (THTL_STS) — RO.</p> <p>0 = No clock throttling is occurring (maximum processor performance).</p> <p>1 = Indicates that the clock state machine is throttling the processor performance. This could be due to the THT_EN bit or the FORCE_THTL bit being set.</p>
16:9	Reserved
8	<p>Force Thermal Throttling (FORCE_THTL) — R/W. Software can set this bit to force the thermal throttling function.</p> <p>0 = No forced throttling.</p> <p>1 = Throttling at the duty cycle specified in THRM_DTY starts immediately, and no SMI# is generated.</p>

Bit	Description																											
7:5	<p>THRM_DTY — WO. This write-once field determines the duty cycle of the throttling when the FORCE_THTL bit is set. The duty cycle indicates the approximate percentage of time the STPCLK# signal is asserted while in the throttle mode. The STPCLK# throttle period is 1024 PCICLKs. Note that the throttling only occurs if the system is in the C0 state. If in the C2, C3, or C4 state, no throttling occurs.</p> <p>Once the THRM_DTY field is written, any subsequent writes will have no effect until PLTRST# goes active.</p> <table border="1"> <thead> <tr> <th>THRM_DTY</th> <th>Throttle Mode</th> <th>PCI Clocks</th> </tr> </thead> <tbody> <tr> <td>000b</td> <td>50% (Default)</td> <td>512</td> </tr> <tr> <td>001b</td> <td>87.5%</td> <td>896</td> </tr> <tr> <td>010b</td> <td>75.0%</td> <td>768</td> </tr> <tr> <td>011b</td> <td>62.5%</td> <td>640</td> </tr> <tr> <td>100b</td> <td>50%</td> <td>512</td> </tr> <tr> <td>101b</td> <td>37.5%</td> <td>384</td> </tr> <tr> <td>110b</td> <td>25%</td> <td>256</td> </tr> <tr> <td>111b</td> <td>12.5%</td> <td>128</td> </tr> </tbody> </table>	THRM_DTY	Throttle Mode	PCI Clocks	000b	50% (Default)	512	001b	87.5%	896	010b	75.0%	768	011b	62.5%	640	100b	50%	512	101b	37.5%	384	110b	25%	256	111b	12.5%	128
THRM_DTY	Throttle Mode	PCI Clocks																										
000b	50% (Default)	512																										
001b	87.5%	896																										
010b	75.0%	768																										
011b	62.5%	640																										
100b	50%	512																										
101b	37.5%	384																										
110b	25%	256																										
111b	12.5%	128																										
4	<p>THTL_EN — R/W. When set and the system is in a C0 state, it enables a processor-controlled STPCLK# throttling. The duty cycle is selected in the THTL_DTY field.</p> <p>0 = Disable 1 = Enable</p>																											
3:1	<p>THTL_DTY — R/W. This field determines the duty cycle of the throttling when the THTL_EN bit is set. The duty cycle indicates the approximate percentage of time the STPCLK# signal is asserted (low) while in the throttle mode. The STPCLK# throttle period is 1024 PCICLKs.</p> <table border="1"> <thead> <tr> <th>THTL_DTY</th> <th>Throttle Mode</th> <th>PCI Clocks</th> </tr> </thead> <tbody> <tr> <td>000b</td> <td>50% (Default)</td> <td>512</td> </tr> <tr> <td>001b</td> <td>87.5%</td> <td>896</td> </tr> <tr> <td>010b</td> <td>75.0%</td> <td>768</td> </tr> <tr> <td>011b</td> <td>62.5%</td> <td>640</td> </tr> <tr> <td>100b</td> <td>50%</td> <td>512</td> </tr> <tr> <td>101b</td> <td>37.5%</td> <td>384</td> </tr> <tr> <td>110b</td> <td>25%</td> <td>256</td> </tr> <tr> <td>111b</td> <td>12.5%</td> <td>128</td> </tr> </tbody> </table>	THTL_DTY	Throttle Mode	PCI Clocks	000b	50% (Default)	512	001b	87.5%	896	010b	75.0%	768	011b	62.5%	640	100b	50%	512	101b	37.5%	384	110b	25%	256	111b	12.5%	128
THTL_DTY	Throttle Mode	PCI Clocks																										
000b	50% (Default)	512																										
001b	87.5%	896																										
010b	75.0%	768																										
011b	62.5%	640																										
100b	50%	512																										
101b	37.5%	384																										
110b	25%	256																										
111b	12.5%	128																										
0	Reserved																											

10.8.3.6 LV2 — Level 2 Register

I/O Address:	PMBASE + 14h (ACPI P_BLK+4)	Attribute:	RO
Default Value:	00h	Size:	8-bit
Lockable:	No	Usage:	ACPI or Legacy
Power Well:	Core		

Bit	Description
7:0	Reads to this register return all 0s, writes to this register have no effect. Reads to this register generate a “enter a level 2 power state” (C2) to the clock control logic. This will cause the STPCLK# signal to go active, and stay active until a break event occurs. Throttling (due either to THTL_EN or FORCE_THTL) will be ignored.

NOTE: This register should not be used by Intel iA64 processors or systems with more than 1 logical processor, unless appropriate semaphoring software has been put in place to ensure that all threads/processors are ready for the C2 state when the read to this register occurs

10.8.3.7 LV3—Level 3 Register (Mobile Only)

I/O Address:	PMBASE + 15h (ACPI P_BLK + 5)	Attribute:	RO
Default Value:	00h	Size:	8-bit
Lockable:	No	Usage:	ACPI or Legacy
		Power Well:	Core

Bit	Description
7:0	Reads to this register return all 0s, writes to this register have no effect. Reads to this register generate a “enter a C3 power state” to the clock control logic. The C3 state persists until a break event occurs.

NOTE: If the C4onC3_EN bit is set, reads this register will initiate a LVL4 transition rather than a LVL3 transition. In the event that software attempts to simultaneously read the LVL2 and LVL3 registers (which is illegal), the ICH6 will ignore the LVL3 read, and only perform a C2 transition.

NOTE: This register should not be used by iA64 processors or systems with more than 1 logical processor, unless appropriate semaphoring software has been put in place to ensure that all threads/processors are ready for the C3 state when the read to this register occurs.

10.8.3.8 LV4—Level 4 Register (Mobile Only)

I/O Address:	PMBASE + 16h (ACPI P_BLK + 6)	Attribute:	RO
Default Value:	00h	Size:	8-bit
Lockable:	No	Usage:	ACPI or Legacy
		Power Well:	Core

Bit	Description
7:0	Reads to this register return all 0s, writes to this register have no effect. Reads to this register generate a “enter a C4 power state” to the clock control logic. The C4 state persists until a break event occurs.

NOTE: This register should not be used by iA64 processors or systems with more than 1 logical processor, unless appropriate semaphoring software has been put in place to ensure that all threads/processors are ready for the C4 state when the read to this register occurs.

10.8.3.9 PM2_CNT—Power Management 2 Control (Mobile Only)

I/O Address:	PMBASE + 20h (ACPI PM2_BLK)	Attribute:	R/W
Default Value:	00h	Size:	8-bit
Lockable:	No	Usage:	ACPI
Power Well:	Core		

Bit	Description
7:1	Reserved
0	Arbiter Disable (ARB_DIS) — R/W. This bit is essentially just a scratchpad bit for legacy software compatibility. Software typically sets this bit to 1 prior to entering a C3 or C4 state. When a transition to a C3 or C4 state occurs, ICH6 will automatically prevent any internal or external non-Isoch bus masters from initiating any cycles up to the (G)MCH. This blocking starts immediately upon the ICH6 sending the Go-C3 message to the (G)MCH. The blocking stops when the Ack-C2 message is received. Note that this is not really blocking, in that messages (such as from PCI Express*) are just queued and held pending.

10.8.3.10 GPE0_STS—General Purpose Event 0 Status Register

I/O Address:	PMBASE + 28h (ACPI GPE0_BLK)	Attribute:	R/W, R/WC
Default Value:	00000000h	Size:	32-bit
Lockable:	No	Usage:	ACPI
Power Well:	Resume		

This register is symmetrical to the General Purpose Event 0 Enable Register. Unless indicated otherwise below, if the corresponding _EN bit is set, then when the _STS bit get set, the ICH6 will generate a Wake Event. Once back in an S0 state (or if already in an S0 state when the event occurs), the ICH6 will also generate an SCI if the SCI_EN bit is set, or an SMI# if the SCI_EN bit (PMBASE + 04h, bit 0) is not set. Bits 31:16 are reset by a CF9h write; bits 15:0 are not. All are reset by RSMRST#.

Bit	Description
31:16	GPIIn_STS — R/WC. 0 = Software clears this bit by writing a 1 to it. 1 = These bits are set any time the corresponding GPIO is set up as an input and the corresponding GPIO signal is high (or low if the corresponding GP_INV bit is set). If the corresponding enable bit is set in the GPE0_EN register, then when the GPI[n]_STS bit is set: <ul style="list-style-type: none"> • If the system is in an S1–S5 state, the event will also wake the system. • If the system is in an S0 state (or upon waking back to an S0 state), a SCI will be caused depending on the GPI_ROUT bits (D31:F0:B8h, bits 31:30) for the corresponding GPI. NOTE: Mapping is as follows: bit 31 corresponds to GPI[15] ... and bit 16 corresponds to GPI:[0].
15	Reserved
14	USB4_STS — R/W. 0 = Disable. 1 = Set by hardware and can be reset by writing a one to this bit position or a resume well reset. This bit is set when USB UHCI controller #4 needs to cause a wake. Additionally if the USB4_EN bit is set, the setting of the USB4_STS bit will generate a wake event.

Bit	Description
13	<p>PME_B0_STS — R/W. This bit will be set to 1 by the ICH6 when any internal device with PCI Power Management capabilities on bus 0 asserts the equivalent of the PME# signal. Additionally, if the PME_B0_EN bit is set, and the system is in an S0 state, then the setting of the PME_B0_STS bit will generate an SCI (or SMI# if SCI_EN is not set). If the PME_B0_STS bit is set, and the system is in an S1–S4 state (or S5 state due to SLP_TYP and SLP_EN), then the setting of the PME_B0_STS bit will generate a wake event, and an SCI (or SMI# if SCI_EN is not set) will be generated. If the system is in an S5 state due to power button override, then the PME_B0_STS bit will not cause a wake event or SCI.</p> <p>The default for this bit is 0. Writing a 1 to this bit position clears this bit.</p>
12	<p>USB3_STS — R/W.</p> <p>0 = Disable. 1 = Set by hardware and can be reset by writing a one to this bit position or a resume well reset. This bit is set when USB UHCI controller #3 needs to cause a wake. Additionally if the USB3_EN bit is set, the setting of the USB3_STS bit will generate a wake event.</p>
11	<p>PME_STS — R/WC.</p> <p>0 = Software clears this bit by writing a 1 to it. 1 = Set by hardware when the PME# signal goes active. Additionally, if the PME_EN bit is set, and the system is in an S0 state, then the setting of the PME_STS bit will generate an SCI or SMI# (if SCI_EN is not set). If the PME_EN bit is set, and the system is in an S1–S4 state (or S5 state due to setting SLP_TYP and SLP_EN), then the setting of the PME_STS bit will generate a wake event, and an SCI will be generated. If the system is in an S5 state due to power button override or a power failure, then PME_STS will not cause a wake event or SCI.</p>
10 (Desktop Only)	Reserved
10 (Mobile Only)	<p>BATLOW_STS — R/WC. (Mobile Only) Software clears this bit by writing a 1 to it.</p> <p>0 = BATLOW# Not asserted 1 = Set by hardware when the BATLOW# signal is asserted.</p>
9	<p>PCI_EXP_STS — R/WC.</p> <p>0 = Software clears this bit by writing a 1 to it. 1 = Set by hardware to indicate that:</p> <ul style="list-style-type: none"> The PME event message was received on one or more of the PCI Express* ports An Assert PMEGPE message received from the (G)MCH via DMI <p>NOTES:</p> <ol style="list-style-type: none"> The PCI WAKE# pin has no impact on this bit. If the PCI_EXP_STS bit went active due to an Assert PMEGPE message, then a de-assert PMEGPE message must be received prior to the software write in order for the bit to be cleared. If the bit is not cleared and the corresponding PCI_EXP_EN bit is set, the level-triggered SCI will remain active. A race condition exists where the PCI Express device sends another PME message because the PCI Express device was not serviced within the time when it must resend the message. This may result in a spurious interrupt, and this is comprehended and approved by the <i>PCI Express* Specification, Revision 1.0a</i>. The window for this race condition is approximately 95-105 milliseconds.
8	<p>RI_STS — R/WC.</p> <p>0 = Software clears this bit by writing a 1 to it. 1 = Set by hardware when the RI# input signal goes active.</p>

Bit	Description
7	<p>SMBus Wake Status (SMB_WAK_STS) — R/WC. The SMBus controller can independently cause an SMI# or SCI, so this bit does not need to do so (unlike the other bits in this register). Software clears this bit by writing a 1 to it.</p> <p>0 = Wake event Not caused by the ICH6's SMBus logic. 1 = Set by hardware to indicate that the wake event was caused by the ICH6's SMBus logic. This bit will be set by the WAKE/SMI# command type, even if the system is already awake. The SMI handler should then clear this bit.</p> <p>NOTES:</p> <ol style="list-style-type: none"> 1. This bit is set by the SMBus slave command 01h (Wake/SMI#) even when the system is in the S0 state. Therefore, to avoid an instant wake on subsequent transitions to sleep states, software must clear this bit after each reception of the Wake/SMI# command or just prior to entering the sleep state. 2. If SMB_WAK_STS is set due to SMBus slave receiving a message, it will be cleared by internal logic when a THRMTRIP# event happens or a Power Button Override event. However, THRMTRIP# or Power Button Override event will not clear SMB_WAK_STS if it is set due to SMBALERT# signal going active. 3. The SMBALERT_STS bit (D31:F3:I/O Offset 00h:Bit 5) should be cleared by software before the SMB_WAK_STS bit is cleared.
6	<p>TCOSCI_STS — R/WC. Software clears this bit by writing a 1 to it.</p> <p>0 = TOC logic did Not cause SCI. 1 = Set by hardware when the TCO logic causes an SCI.</p>
5	<p>AC97_STS — R/WC. This bit will be set to 1 when the codecs are attempting to wake the system and the PME events for the codecs are armed for wakeup. A PME is armed by programming the appropriate PMEE bit in the Power Management Control and Status register at bit 8 of offset 54h in each AC '97 function.</p> <p>0 = Software clears this bit by writing a 1 to it. 1 = Set by hardware when the codecs are attempting to wake the system. The AC97_STS bit gets set only from the following two cases:</p> <ol style="list-style-type: none"> 1. The PMEE bit for the function is set, and o The AC-link bit clock has been shut and the routed ACZ_SDIN line is high (for audio, if routing is disabled, no wake events are allowed. 2. For modem, if audio routing is disabled, then the wake event is an OR of all ACZ_SDIN lines. If routing is enabled, then the wake event for modem is the remaining non-routed ACZ_SDIN line), or o GPI Status Change Interrupt bit (NABMBAR + 30h, bit 0) is 1. <p>NOTE: This bit is not affected by a hard reset caused by a CF9h write. NOTE: This bit is also used for Intel High Definition Audio when ICH6 is configured to use the Intel High Definition Audio host controller rather than the AC97 host controller.</p>
4	<p>USB2_STS — R/WC. Software clears this bit by writing a 1 to it.</p> <p>0 = USB UHCI controller 2 does Not need to cause a wake. 1 = Set by hardware when USB UHCI controller 2 needs to cause a wake. Wake event will be generated if the corresponding USB2_EN bit is set.</p>
3	<p>USB1_STS — R/WC. Software clears this bit by writing a 1 to it.</p> <p>0 = USB UHCI controller 1 does Not need to cause a wake. 1 = Set by hardware when USB UHCI controller 1 needs to cause a wake. Wake event will be generated if the corresponding USB1_EN bit is set.</p>
2	Reserved
1	<p>HOT_PLUG_STS — R/WC.</p> <p>0 = This bit is cleared by writing a 1 to this bit position. 1 = When a PCI Express* Hot-Plug event occurs. This will cause an SCI if the HOT_PLUG_EN bit is set in the GEPO_EN register.</p>
0	<p>Thermal Interrupt Status (THRM_STS) — R/WC. Software clears this bit by writing a 1 to it.</p> <p>0 = THRM# signal Not driven active as defined by the THRM_POL bit 1 = Set by hardware anytime the THRM# signal is driven active as defined by the THRM_POL bit. Additionally, if the THRM_EN bit is set, then the setting of the THRM_STS bit will also generate a power management event (SCI or SMI#).</p>

10.8.3.11 GPE0_EN—General Purpose Event 0 Enables Register

I/O Address:	PMBASE + 2Ch (ACPI GPE0_BLK + 4)	Attribute:	R/W
Default Value:	00000000h	Size:	32-bit
Lockable:	No	Usage:	ACPI
Power Well:	Bits 0–7, 9, 12, 14–31 Resume, Bits 8, 10–11, 13 RTC		

This register is symmetrical to the General Purpose Event 0 Status Register. All the bits in this register should be cleared to 0 based on a Power Button Override or processor Thermal Trip event. The resume well bits are all cleared by RSMRST#. The RTC sell bits are cleared by RTCRST#.

Bit	Description
31:16	GPI_n_EN — R/W. These bits enable the corresponding GPI[n]_STS bits being set to cause a SCI, and/or wake event. These bits are cleared by RSMRST#. NOTE: Mapping is as follows: bit 31 corresponds to GPI[15] ... and bit 16 corresponds to GPI[0].
15	Reserved
14	USB4_EN — R/W. 0 = Disable. 1 = Enable the setting of the USB4_STS bit to generate a wake event. The USB4_STS bit is set anytime USB UHCI controller #4 signals a wake event. Break events are handled via the USB interrupt.
13	PME_B0_EN — R/W. 0 = Disable 1 = Enables the setting of the PME_B0_STS bit to generate a wake event and/or an SCI or SMI#. PME_B0_STS can be a wake event from the S1–S4 states, or from S5 (if entered via SLP_TYP and SLP_EN) or power failure, but not Power Button Override. This bit defaults to 0. NOTE: It is only cleared by Software or RTCRST#. It is not cleared by CF9h writes.
12	USB3_EN — R/W. 0 = Disable. 1 = Enable the setting of the USB3_STS bit to generate a wake event. The USB3_STS bit is set anytime USB UHCI controller #3 signals a wake event. Break events are handled via the USB interrupt.
11	PME_EN — R/W. 0 = Disable. 1 = Enables the setting of the PME_STS to generate a wake event and/or an SCI. PME# can be a wake event from the S1 – S4 state or from S5 (if entered via SLP_EN, but not power button override).
10 (Desktop Only)	Reserved
10 (Mobile Only)	BATLOW_EN — R/W. (Mobile Only) 0 = Disable. 1 = Enables the BATLOW# signal to cause an SMI# or SCI (depending on the SCI_EN bit) when it goes low. This bit does not prevent the BATLOW# signal from inhibiting the wake event.
9	PCI_EXP_EN — R/W. 0 = Disable SCI generation upon PCI_EXP_STS bit being set. 1 = Enables ICH6 to cause an SCI when PCI_EXP_STS bit is set. This is used to allow the PCI Express* ports, including the link to the (G)MCH, to cause an SCI due to wake/PME events.

Bit	Description
8	RI_EN — R/W. The value of this bit will be maintained through a G3 state and is not affected by a hard reset caused by a CF9h write. 0 = Disable. 1 = Enables the setting of the RI_STS to generate a wake event.
7	Reserved
6	TCOSCI_EN — R/W. 0 = Disable. 1 = Enables the setting of the TCOSCI_STS to generate an SCI.
5	AC97_EN — R/W. 0 = Disable. 1 = Enables the setting of the AC97_STS to generate a wake event. NOTE: This bit is also used for Intel High Definition Audio when the Intel High Definition Audio host controller is enabled rather than the AC97 host controller.
4	USB2_EN — R/W. 0 = Disable. 1 = Enables the setting of the USB2_STS to generate a wake event.
3	USB1_EN — R/W. 0 = Disable. 1 = Enables the setting of the USB1_STS to generate a wake event.
2	THRM#_POL — R/W. This bit controls the polarity of the THRM# pin needed to set the THRM_STS bit. 0 = Low value on the THRM# signal will set the THRM_STS bit. 1 = HIGH value on the THRM# signal will set the THRM_STS bit.
1	HOT_PLUG_EN — R/W. 0 = Disables SCI generation upon the HOT_PLUG_STS bit being set. 1 = Enables the ICH6 to cause an SCI when the HOT_PLUG_STS bit is set. This is used to allow the PCI Express ports to cause an SCI due to hot-plug events.
0	THRM_EN — R/W. 0 = Disable. 1 = Active assertion of the THRM# signal (as defined by the THRM_POL bit) will set the THRM_STS bit and generate a power management event (SCI or SMI).

10.8.3.12 SMI_EN—SMI Control and Enable Register

I/O Address:	PMBASE + 30h	Attribute:	R/W, R/W (special), WO
Default Value:	00000000h	Size:	32 bit
Lockable:	No	Usage:	ACPI or Legacy
Power Well:	Core		

Note: This register is symmetrical to the SMI status register.

Bit	Description
31:19	Reserved
18	INTEL_USB2_EN — R/W. 0 = Disable 1 = Enables Intel-Specific USB2 SMI logic to cause SMI#.
17	LEGACY_USB2_EN — R/W. 0 = Disable 1 = Enables legacy USB2 logic to cause SMI#.
16:15	Reserved
14	PERIODIC_EN — R/W. 0 = Disable. 1 = Enables the ICH6 to generate an SMI# when the PERIODIC_STS bit (PMBASE + 34h, bit 14) is set in the SMI_STS register (PMBASE + 34h).
13	TCO_EN — R/W. 0 = Disables TCO logic generating an SMI#. Note that if the NMI2SMI_EN bit is set, SMIs that are caused by re-routed NMIs will not be gated by the TCO_EN bit. Even if the TCO_EN bit is 0, NMIs will still be routed to cause SMIs. 1 = Enables the TCO logic to generate SMI#. NOTE: This bit cannot be written once the TCO_LOCK bit is set.
12	Reserved
11	MCSMI_EN Microcontroller SMI Enable (MCSMI_EN) — R/W. 0 = Disable. 1 = Enables ICH6 to trap accesses to the microcontroller range (62h or 66h) and generate an SMI#. Note that "trapped" cycles will be claimed by the ICH6 on PCI, but not forwarded to LPC.
10:8	Reserved
7	BIOS Release (BIOS_RLS) — WO. 0 = This bit will always return 0 on reads. Writes of 0 to this bit have no effect. 1 = Enables the generation of an SCI interrupt for ACPI software when a one is written to this bit position by BIOS software. NOTE: GBL_STS being set will cause an SCI, even if the SCI_EN bit is not set. Software must take great care not to set the BIOS_RLS bit (which causes GBL_STS to be set) if the SCI handler is not in place.
6	Software SMI# Timer Enable (SWSMI_TMR_EN) — R/W. 0 = Disable. Clearing the SWSMI_TMR_EN bit before the timer expires will reset the timer and the SMI# will not be generated. 1 = Starts Software SMI# Timer. When the SWSMI timer expires (the timeout period depends upon the SWSMI_RATE_SEL bit setting), SWSMI_TMR_STS is set and an SMI# is generated. SWSMI_TMR_EN stays set until cleared by software.
5	APMC_EN — R/W. 0 = Disable. Writes to the APM_CNT register will not cause an SMI#. 1 = Enables writes to the APM_CNT register to cause an SMI#.

Bit	Description
4	<p>SLP_SMI_EN — R/W.</p> <p>0 = Disables the generation of SMI# on SLP_EN. Note that this bit must be 0 before the software attempts to transition the system into a sleep state by writing a 1 to the SLP_EN bit.</p> <p>1 = A write of 1 to the SLP_EN bit (bit 13 in PM1_CNT register) will generate an SMI#, and the system will not transition to the sleep state based on that write to the SLP_EN bit.</p>
3	<p>LEGACY_USB_EN — R/W.</p> <p>0 = Disable.</p> <p>1 = Enables legacy USB circuit to cause SMI#.</p>
2	<p>BIOS_EN — R/W.</p> <p>0 = Disable.</p> <p>1 = Enables the generation of SMI# when ACPI software writes a 1 to the GBL_RLS bit (D31:F0:PMBase + 04h:bit 2). Note that if the BIOS_STS bit (D31:F0:PMBase + 34h:bit 2), which gets set when software writes 1 to GBL_RLS bit, is already a 1 at the time that BIOS_EN becomes 1, an SMI# will be generated when BIOS_EN gets set.</p>
1	<p>End of SMI (EOS) — R/W (special). This bit controls the arbitration of the SMI signal to the processor. This bit must be set for the ICH6 to assert SMI# low to the processor after SMI# has been asserted previously.</p> <p>0 = Once the ICH6 asserts SMI# low, the EOS bit is automatically cleared.</p> <p>1 = When this bit is set to 1, SMI# signal will be de-asserted for 4 PCI clocks before its assertion. In the SMI handler, the processor should clear all pending SMIs (by servicing them and then clearing their respective status bits), set the EOS bit, and exit SMM. This will allow the SMI arbiter to re-assert SMI upon detection of an SMI event and the setting of a SMI status bit.</p> <p>NOTE: ICH6 is able to generate 1st SMI after reset even though EOS bit is not set. Subsequent SMI require EOS bit is set.</p>
0	<p>GBL_SMI_EN — R/W.</p> <p>0 = No SMI# will be generated by ICH6. This bit is reset by a PCI reset event.</p> <p>1 = Enables the generation of SMI# in the system upon any enabled SMI event.</p> <p>NOTE: When the SMI_LOCK bit is set, this bit cannot be changed.</p>

10.8.3.13 SMI_STS—SMI Status Register

I/O Address:	PMBASE + 34h	Attribute:	RO, R/WC
Default Value:	00000000h	Size:	32-bit
Lockable:	No	Usage:	ACPI or Legacy
Power Well:	Core		

Note: If the corresponding `_EN` bit is set when the `_STS` bit is set, the ICH6 will cause an SMI# (except bits 8–10 and 12, which do not need enable bits since they are logic ORs of other registers that have enable bits). The ICH6 uses the same `GPE0_EN` register (I/O address: `PMBASE+2Ch`) to enable/disable both SMI and ACPI SCI general purpose input events. ACPI OS assumes that it owns the entire `GPE0_EN` register per ACPI spec. Problems arise when some of the general-purpose inputs are enabled as SMI by BIOS, and some of the general purpose inputs are enabled for SCI. In this case ACPI OS turns off the enabled bit for any GPIx input signals that are not indicated as SCI general-purpose events at boot, and exit from sleeping states. BIOS should define a dummy control method which prevents the ACPI OS from clearing the SMI `GPE0_EN` bits.

Bit	Description
31:20	Reserved
21	MONITOR_STS — RO. This bit will be set if the Trap/SMI logic has caused the SMI. This will occur when the processor or a bus master accesses an assigned register (or a sequence of accesses). See Section 7.1.32 thru Section 7.1.35 for details on the specific cause of the SMI.
20	PCI_EXP_SMI_STS — RO. PCI Express* SMI event occurred. This could be due to a PCI Express PME event or Hot-Plug event.
19	Reserved
18	INTEL_USB2_STS — RO. This non-sticky read-only bit is a logical OR of each of the SMI status bits in the Intel-Specific USB2 SMI Status Register ANDed with the corresponding enable bits. This bit will not be active if the enable bits are not set. Writes to this bit will have no effect.
17	LEGACY_USB2_STS — RO. This non-sticky read-only bit is a logical OR of each of the SMI status bits in the USB2 Legacy Support Register ANDed with the corresponding enable bits. This bit will not be active if the enable bits are not set. Writes to this bit will have no effect.
16	SMBus SMI Status (SMBus_SMI_STS) — R/WC. Software clears this bit by writing a 1 to it. 0 = This bit is set from the 64 kHz clock domain used by the SMBus. Software must wait at least 15.63 us after the initial assertion of this bit before clearing it. 1 = Indicates that the SMI# was caused by: 1. The SMBus Slave receiving a message that an SMI# should be caused, or 2. The SMBALERT# signal goes active and the <code>SMB_SMI_EN</code> bit is set and the <code>SMBALERT_DIS</code> bit is cleared, or 3. The SMBus Slave receiving a Host Notify message and the <code>HOST_NOTIFY_INTREN</code> and the <code>SMB_SMI_EN</code> bits are set, or 4. The ICH6 detecting the <code>SMLINK_SLAVE_SMI</code> command while in the <code>S0</code> state.
15	SERIRQ_SMI_STS — RO. 0 = SMI# was not caused by the SERIRQ decoder. 1 = Indicates that the SMI# was caused by the SERIRQ decoder. NOTE: This is not a sticky bit
14	PERIODIC_STS — R/WC. Software clears this bit by writing a 1 to it. 0 = Software clears this bit by writing a 1 to it. 1 = This bit is set at the rate determined by the <code>PER_SMI_SEL</code> bits. If the <code>PERIODIC_EN</code> bit (<code>PMBASE + 30h</code> , bit 14) is also set, the ICH6 generates an SMI#.
13	TCO_STS — R/WC. Software clears this bit by writing a 1 to it. 0 = SMI# not caused by TCO logic. 1 = Indicates the SMI# was caused by the TCO logic. Note that this is not a wake event.

Bit	Description
12	Device Monitor Status (DEVMON_STS) — RO. 0 = SMI# not caused by Device Monitor. 1 = Set if bit 0 of the DEVACT_STS register (PMBASE + 44h) is set. The bit is not sticky, so writes to this bit will have no effect.
11	Microcontroller SMI# Status (MCSMI_STS) — R/WC. Software clears this bit by writing a 1 to it. 0 = Indicates that there has been no access to the power management microcontroller range (62h or 66h). 1 = Set if there has been an access to the power management microcontroller range (62h or 66h) and the Microcontroller Decode Enable #1 bit in the LPC Bridge I/O Enables configuration register is 1 (D31:F0:Offset 82h:bit 11). Note that this implementation assumes that the Microcontroller is on LPC. If this bit is set, and the MCSMI_EN bit is also set, the ICH6 will generate an SMI#.
10	GPE0_STS — RO. This bit is a logical OR of the bits in the ALT_GP_SMI_STS register that are also set up to cause an SMI# (as indicated by the GPI_ROUT registers) and have the corresponding bit set in the ALT_GP_SMI_EN register. Bits that are not routed to cause an SMI# will have no effect on this bit. 0 = SMI# was not generated by a GPI assertion. 1 = SMI# was generated by a GPI assertion.
9	GPE0_STS — RO. This bit is a logical OR of the bits 14:10, 8:2, and 0 in the GPE0_STS register (PMBASE + 28h) that also have the corresponding bit set in the GPE0_EN register (PMBASE + 2Ch). 0 = SMI# was not generated by a GPE0 event. 1 = SMI# was generated by a GPE0 event.
8	PM1_STS_REG — RO. This is an ORs of the bits in the ACPI PM1 Status Register (offset PMBASE+00h) that can cause an SMI#. 0 = SMI# was not generated by a PM1_STS event. 1 = SMI# was generated by a PM1_STS event.
7	Reserved
6	SWSMI_TMR_STS — R/WC. Software clears this bit by writing a 1 to it. 0 = Software SMI# Timer has Not expired. 1 = Set by the hardware when the Software SMI# Timer expires.
5	APM_STS — R/WC. Software clears this bit by writing a 1 to it. 0 = No SMI# generated by write access to APM Control register with APMCH_EN bit set. 1 = SMI# was generated by a write access to the APM Control register with the APMC_EN bit set.
4	SLP_SMI_STS — R/WC. Software clears this bit by writing a 1 to the bit location. 0 = No SMI# caused by write of 1 to SLP_EN bit when SLP_SMI_EN bit is also set. 1 = Indicates an SMI# was caused by a write of 1 to SLP_EN bit when SLP_SMI_EN bit is also set.
3	LEGACY_USB_STS — RO. This bit is a logical OR of each of the SMI status bits in the USB Legacy Keyboard/Mouse Control Registers ANDed with the corresponding enable bits. This bit will not be active if the enable bits are not set. 0 = SMI# was not generated by USB Legacy event. 1 = SMI# was generated by USB Legacy event.
2	BIOS_STS — R/WC. 0 = No SMI# generated due to ACPI software requesting attention. 1 = This bit gets set by hardware when a 1 is written by software to the GBL_RLS bit (D31:F0:PMBase + 04h:bit 2). When both the BIOS_EN bit (D31:F0:PMBase + 30h:bit 2) and the BIOS_STS bit are set, an SMI# will be generated. The BIOS_STS bit is cleared when software writes a 1 to its bit position.
1:0	Reserved

10.8.3.14 ALT_GP_SMI_EN—Alternate GPI SMI Enable Register

I/O Address:	PMBASE +38h	Attribute:	R/W
Default Value:	0000h	Size:	16-bit
Lockable:	No	Usage:	ACPI or Legacy
Power Well:	Resume		

Bit	Description
15:0	<p>Alternate GPI SMI Enable — R/W. These bits are used to enable the corresponding GPIO to cause an SMI#. For these bits to have any effect, the following must be true.</p> <ul style="list-style-type: none"> The corresponding bit in the ALT_GP_SMI_EN register is set. The corresponding GPI must be routed in the GPI_ROUT register to cause an SMI. The corresponding GPIO must be implemented. <p>NOTE: Mapping is as follows: bit 15 corresponds to GPI[15] ... bit 0 corresponds to GPI[0].</p>

10.8.3.15 ALT_GP_SMI_STS—Alternate GPI SMI Status Register

I/O Address:	PMBASE +3Ah	Attribute:	R/WC
Default Value:	0000h	Size:	16-bit
Lockable:	No	Usage:	ACPI or Legacy
Power Well:	Resume		

Bit	Description
15:0	<p>Alternate GPI SMI Status — R/WC. These bits report the status of the corresponding GPIs.</p> <p>0 = Inactive. Software clears this bit by writing a 1 to it.</p> <p>1 = Active</p> <p>These bits are sticky. If the following conditions are true, then an SMI# will be generated and the GPE0_STS bit set:</p> <ul style="list-style-type: none"> The corresponding bit in the ALT_GPI_SMI_EN register (PMBASE + 38h) is set The corresponding GPI must be routed in the GPI_ROUT register to cause an SMI. The corresponding GPIO must be implemented. <p>All bits are in the resume well. Default for these bits is dependent on the state of the GPI pins.</p>

10.8.3.16 DEVACT_STS — Device Activity Status Register

I/O Address:	PMBASE +44h	Attribute:	R/WC
Default Value:	0000h	Size:	16-bit
Lockable:	No	Usage:	Legacy Only
Power Well:	Core		

Each bit indicates if an access has occurred to the corresponding device’s trap range, or for bits 6:9 if the corresponding PCI interrupt is active. This register is used in conjunction with the Periodic SMI# timer to detect any system activity for legacy power management. The periodic SMI# timer indicates if it is the right time to read the DEVACT_STS register (PMBASE + 44h).

Note: Software clears bits that are set in this register by writing a 1 to the bit position.

Bit	Description
15:13	Reserved
12	KBC_ACT_STS — R/WC. KBC (60/64h). 0 = Indicates that there has been no access to this device’s I/O range. 1 = This device’s I/O range has been accessed. Clear this bit by writing a 1 to the bit location.
11:10	Reserved
9	PIRQDH_ACT_STS — R/WC. PIRQ[D or H]. 0 = The corresponding PCI interrupts have not been active. 1 = At least one of the corresponding PCI interrupts has been active. Clear this bit by writing a 1 to the bit location.
8	PIRQCG_ACT_STS — R/WC. PIRQ[C or G]. 0 = The corresponding PCI interrupts have not been active. 1 = At least one of the corresponding PCI interrupts has been active. Clear this bit by writing a 1 to the bit location.
7	PIRQBF_ACT_STS — R/WC. PIRQ[B or F]. 0 = The corresponding PCI interrupts have not been active. 1 = At least one of the corresponding PCI interrupts has been active. Clear this bit by writing a 1 to the bit location.
6	PIRQAE_ACT_STS — R/WC. PIRQ[A or E]. 0 = The corresponding PCI interrupts have not been active. 1 = At least one of the corresponding PCI interrupts has been active. Clear this bit by writing a 1 to the bit location.
5:1	Reserved
0	IDE_ACT_STS — R/WC. IDE Primary Drive 0 and Drive 1. 0 = Indicates that there has been no access to this device’s I/O range. 1 = This device’s I/O range has been accessed. The enable bit is in the ATC register (D31:F1:Offset C0h). Clear this bit by writing a 1 to the bit location.

10.8.3.17 SS_CNT— Intel SpeedStep® Technology Control Register (Mobile Only)

I/O Address:	PMBASE +50h	Attribute:	R/W (special)
Default Value:	01h	Size:	8-bit
Lockable:	No	Usage:	ACPI/Legacy
Power Well:	Core		

Note: Writes to this register will initiate an Intel SpeedStep technology transition that involves a temporary transition to a C3-like state in which the STPCLK# signal will go active. An Intel SpeedStep technology transition **always** occur on writes to the SS_CNT register, even if the value written to SS_STATE is the same as the previous value (after this “transition” the system would still be in the same Intel SpeedStep technology state). If the SS_EN bit is 0, then writes to this register will have no effect and reads will return 0.

Bit	Description
7:1	Reserved
0	<p>SS_STATE (Intel SpeedStep® technology State) — R/W (Special). When this bit is read, it returns the last value written to this register. By convention, this will be the current Intel SpeedStep technology state. Writes to this register causes a change to the Intel SpeedStep technology state indicated by the value written to this bit. If the new value for SS_STATE is the same as the previous value, then transition will still occur.</p> <p>0 = High power state. 1 = Low power state</p> <p>NOTE: This is only a convention because the transition is the same regardless of the value written to this bit.</p>

10.8.3.18 C3_RES— C3 Residency Register (Mobile Only)

I/O Address:	PMBASE +54h	Attribute:	RW/RO
Default Value:	00000000h	Size:	32-bit
Lockable:	No	Usage:	ACPI/Legacy
Power Well:	Core		

Software may only write this register during system initialization to set the state of the C3_RESIDENCY_MODE bit. It must not be written while the timer is in use.

Bit	Description
31	<p>C3_RESEDENCY_MODE — RW.</p> <p>When this bit is 0, the C3_RESIDENCY counter field will automatically clear upon entry into the C3 or C4 state. When this bit is 1, the C3_RESIDENCY counter will not automatically clear upon entry into the C3 or C4 state.</p>
30:24	Reserved
23:0	<p>C3_RESIDENCY — RO. The value in this field increments at the same rate as the Power Management Timer. If the C3_RESEDENCY_MODE bit is clear, this field automatically resets to 0 at the point when the Lvl3 or Lvl4 read occurs. If the C3_RESIDENCY_MODE bit is set, the register does not reset when the Lvl3 or Lvl4 read occurs. In either mode, it increments while STP_CPU# is active (i.e. the processor is in a C3 or C4 state). This field will roll over in the same way as the PM Timer, however the most significant bit is NOT sticky.</p> <p>Software is responsible for reading this field before performing the Lvl3/4 transition. Software must also check for rollover if the maximum time in C3/C4 could be exceeded.</p>

10.9 System Management TCO Registers (D31:F0)

The TCO logic is accessed via registers mapped to the PCI configuration space (Device 31:Function 0) and the system I/O space. For TCO PCI Configuration registers, see LPC Device 31:Function 0 PCI Configuration registers.

TCO Register I/O Map

The TCO I/O registers reside in a 32-byte range pointed to by a TCOBASE value, which is, PMBASE + 60h in the PCI configuration space. The following table shows the mapping of the registers within that 32-byte range. Each register is described in the following sections.

Table 10-12. TCO I/O Register Address Map

TCOBASE + Offset	Mnemonic	Register Name	Default	Type
00h–01h	TCO_RLD	TCO Timer Reload and Current Value	0000h	R/W
02h	TCO_DAT_IN	TCO Data In	00h	R/W
03h	TCO_DAT_OUT	TCO Data Out	00h	R/W
04h–05h	TCO1_STS	TCO1 Status	0000h	R/WC, RO
06h–07h	TCO2_STS	TCO2 Status	0000h	R/W, R/WC
08h–09h	TCO1_CNT	TCO1 Control	0000h	R/W, R/W (special), R/WC
0Ah–0Bh	TCO2_CNT	TCO2 Control	0008h	R/W
0Ch–0Dh	TCO_MESSAGE1, TCO_MESSAGE2	TCO Message 1 and 2	00h	R/W
0Eh	TCO_WDCNT	Watchdog Control	00h	R/W
0Fh	—	Reserved	—	—
10h	SW_IRQ_GEN	Software IRQ Generation	11h	R/W
11h	—	Reserved	—	—
12h–13h	TCO_TMR	TCO Timer Initial Value	0004h	R/W
14h–1Fh	—	Reserved	—	—

10.9.1 TCO_RLD—TCO Timer Reload and Current Value Register

I/O Address:	TCOBASE +00h	Attribute:	R/W
Default Value:	0000h	Size:	16-bit
Lockable:	No	Power Well:	Core

Bit	Description
15:10	Reserved
9:0	TCO Timer Value — R/W. Reading this register will return the current count of the TCO timer. Writing any value to this register will reload the timer to prevent the timeout.

10.9.2 TCO_DAT_IN—TCO Data In Register

I/O Address: TCOBASE +02h Attribute: R/W
 Default Value: 00h Size: 8-bit
 Lockable: No Power Well: Core

Bit	Description
7:0	TCO Data In Value — R/W. This data register field is used for passing commands from the OS to the SMI handler. Writes to this register will cause an SMI and set the SW_TCO_SMI bit in the TCO1_STS register (D31:F0:04h).

10.9.3 TCO_DAT_OUT—TCO Data Out Register

I/O Address: TCOBASE +03h Attribute: R/W
 Default Value: 00h Size: 8-bit
 Lockable: No Power Well: Core

Bit	Description
7:0	TCO Data Out Value — R/W. This data register field is used for passing commands from the SMI handler to the OS. Writes to this register will set the TCO_INT_STS bit in the TCO_STS register. It will also cause an interrupt, as selected by the TCO_INT_SEL bits.

10.9.4 TCO1_STS—TCO1 Status Register

I/O Address: TCOBASE +04h Attribute: R/WC, RO
 Default Value: 0000h Size: 16-bit
 Lockable: No Power Well: Core
 (Except bit 7, in RTC)

Bit	Description
15:13	Reserved
12	DMISERR_STS — R/WC. 0 = Software clears this bit by writing a 1 to it. 1 = ICH6 received a DMI special cycle message via DMI indicating that it wants to cause an SERR#. The software must read the (G)MCH to determine the reason for the SERR#.
11	Reserved
10	DMISMI_STS — R/WC. 0 = Software clears this bit by writing a 1 to it. 1 = ICH6 received a DMI special cycle message via DMI indicating that it wants to cause an SMI. The software must read the (G)MCH to determine the reason for the SMI.
9	DMISCI_STS — R/WC. 0 = Software clears this bit by writing a 1 to it. 1 = ICH6 received a DMI special cycle message via DMI indicating that it wants to cause an SCI. The software must read the (G)MCH to determine the reason for the SCI.

Bit	Description
8	<p>BIOSWR_STS — R/WC.</p> <p>0 = Software clears this bit by writing a 1 to it. 1 = ICH6 sets this bit and generates an SMI# to indicate an illegal attempt to write to the BIOS. This occurs when either: a) The BIOSWP bit is changed from 0 to 1 and the BLD bit is also set, or b) any write is attempted to the BIOS and the BIOSWP bit is also set.</p> <p>NOTE: On write cycles attempted to the 4 MB lower alias to the BIOS space, the BIOSWR_STS will not be set.</p>
7	<p>NEWCENTURY_STS — R/WC. This bit is in the RTC well.</p> <p>0 = Cleared by writing a 1 to the bit position or by RTCRST# going active. 1 = This bit is set when the Year byte (RTC I/O space, index offset 09h) rolls over from 99 to 00. Setting this bit will cause an SMI# (but not a wake event).</p> <p>NOTE: The NEWCENTURY_STS bit is not valid when the RTC battery is first installed (or when RTC power has not been maintained). Software can determine if RTC power has not been maintained by checking the RTC_PWR_STS bit (D31:F0:A4h, bit 2), or by other means (such as a checksum on RTC RAM). If RTC power is determined to have not been maintained, BIOS should set the time to a legal value and then clear the NEWCENTURY_STS bit.</p> <p>The NEWCENTURY_STS bit may take up to 3 RTC clocks for the bit to be cleared after a 1 is written to the bit to clear it. After writing a 1 to this bit, software should not exit the SMI handler until verifying that the bit has actually been cleared. This will ensure that the SMI is not re-entered.</p>
6:4	Reserved
3	<p>TIMEOUT — R/WC.</p> <p>0 = Software clears this bit by writing a 1 to it. 1 = Set by ICH6 to indicate that the SMI was caused by the TCO timer reaching 0.</p>
2	<p>TCO_INT_STS — R/WC.</p> <p>0 = Software clears this bit by writing a 1 to it. 1 = SMI handler caused the interrupt by writing to the TCO_DAT_OUT register (TCOBASE + 03h).</p>
1	<p>SW_TCO_SMI — R/WC.</p> <p>0 = Software clears this bit by writing a 1 to it. 1 = Software caused an SMI# by writing to the TCO_DAT_IN register (TCOBASE + 02h).</p>
0	<p>NMI2SMI_STS — RO.</p> <p>0 = Cleared by clearing the associated NMI status bit. 1 = Set by the ICH6 when an SMI# occurs because an event occurred that would otherwise have caused an NMI (because NMI2SMI_EN is set).</p>

10.9.5 TCO2_STS—TCO2 Status Register

I/O Address:	TCOBASE +06h	Attribute:	R/W, R/WC
Default Value:	0000h	Size:	16-bit
Lockable:	No	Power Well:	Resume (Except Bit 0, in RTC)

Bit	Description
15:5	Reserved
4	<p>SMLink Slave SMI Status (SMLINK_SLV_SMI_STS) — R/WC. Allow the software to go directly into pre-determined sleep state. This avoids race conditions. Software clears this bit by writing a 1 to it.</p> <p>0 = The bit is reset by RSMRST#, but not due to the PCI Reset associated with exit from S3–S5 states.</p> <p>1 = ICH6 sets this bit to 1 when it receives the SMI message on the SMLink's Slave Interface.</p>
3	Reserved
2	<p>BOOT_STS — R/WC.</p> <p>0 = Cleared by ICH6 based on RSMRST# or by software writing a 1 to this bit. Note that software should first clear the SECOND_TO_STS bit before writing a 1 to clear the BOOT_STS bit.</p> <p>1 = Set to 1 when the SECOND_TO_STS bit goes from 0 to 1 and the processor has not fetched the first instruction.</p> <p>If rebooting due to a second TCO timer timeout, and if the BOOT_STS bit is set, the ICH6 will reboot using the 'safe' multiplier (1111). This allows the system to recover from a processor frequency multiplier that is too high, and allows the BIOS to check the BOOT_STS bit at boot. If the bit is set and the frequency multiplier is 1111, then the BIOS knows that the processor has been programmed to an illegal multiplier.</p>
1	<p>SECOND_TO_STS — R/WC.</p> <p>0 = Software clears this bit by writing a 1 to it, or by a RSMRST#.</p> <p>1 = ICH6 sets this bit to 1 to indicate that the TIMEOUT bit had been (or is currently) set and a second timeout occurred before the TCO_RLD register was written. If this bit is set and the NO_REBOOT configuration bit is 0, then the ICH6 will reboot the system after the second timeout. The reboot is done by asserting PLTRST#.</p>
0	<p>Intruder Detect (INTRD_DET) — R/WC.</p> <p>0 = Software clears this bit by writing a 1 to it, or by RTCRST# assertion.</p> <p>1 = Set by ICH6 to indicate that an intrusion was detected. This bit is set even if the system is in G3 state.</p> <p>NOTES:</p> <ol style="list-style-type: none"> This bit has a recovery time. After writing a 1 to this bit position (to clear it), the bit may be read back as a 1 for up to 65 microseconds before it is read as a 0. Software must be aware of this recovery time when reading this bit after clearing it. If the INTRUDER# signal is active when the software attempts to clear the INTRD_DET bit, the bit will remain as a 1, and the SMI# will be generated again immediately. The SMI handler can clear the INTRD_SEL bits (TCOBASE + 0Ah, bits 2:1), to avoid further SMIs. However, if the INTRUDER# signal goes inactive and then active again, there will not be further SMIs (because the INTRD_SEL bits would select that no SMI# be generated). If the INTRUDER# signal goes inactive some point after the INTRD_DET bit is written as a 1, then the INTRD_DET signal will go to a 0 when INTRUDER# input signal goes inactive. Note that this is slightly different than a classic sticky bit, since most sticky bits would remain active indefinitely when the signal goes active and would immediately go inactive when a 1 is written to the bit.

10.9.6 TCO1_CNT—TCO1 Control Register

I/O Address:	TCOBASE +08h	Attribute:	R/W, R/W (special), R/WC
Default Value:	0000h	Size:	16-bit
Lockable:	No	Power Well:	Core

Bit	Description															
15:13	Reserved															
12	TCO_LOCK — R/W (special). When set to 1, this bit prevents writes from changing the TCO_EN bit (in offset 30h of Power Management I/O space). Once this bit is set to 1, it can not be cleared by software writing a 0 to this bit location. A core-well reset is required to change this bit from 1 to 0. This bit defaults to 0.															
11	TCO Timer Halt (TCO_TMR_HLT) — R/W. 0 = The TCO Timer is enabled to count. 1 = The TCO Timer will halt. It will not count, and thus cannot reach a value that will cause an SMI# or set the SECOND_TO_STS bit. When set, this bit will prevent rebooting and prevent Alert On LAN event messages from being transmitted on the SMLINK (but not Alert On LAN* heartbeat messages).															
10	SEND_NOW — R/W (special). 0 = The ICH6 will clear this bit when it has completed sending the message. Software must not set this bit to 1 again until the ICH6 has set it back to 0. 1 = Writing a 1 to this bit will cause the ICH6 to send an Alert On LAN Event message over the SMLINK interface, with the Software Event bit set. Setting the SEND_NOW bit causes the ICH6 integrated LAN controller to reset, which can have unpredictable side-effects. Unless software protects against these side effects, software should not attempt to set this bit.															
9	NMI2SMI_EN — R/W. 0 = Normal NMI functionality. 1 = Forces all NMIs to instead cause SMIs. The functionality of this bit is dependent upon the settings of the NMI_EN bit and the GBL_SMI_EN bit as detailed in the following table:															
	<table border="1"> <thead> <tr> <th>NMI_EN</th> <th>GBL_SMI_EN</th> <th>Description</th> </tr> </thead> <tbody> <tr> <td>0b</td> <td>0b</td> <td>No SMI# at all because GBL_SMI_EN = 0</td> </tr> <tr> <td>0b</td> <td>1b</td> <td>SMI# will be caused due to NMI events</td> </tr> <tr> <td>1b</td> <td>0b</td> <td>No SMI# at all because GBL_SMI_EN = 0</td> </tr> <tr> <td>1b</td> <td>1b</td> <td>No SMI# due to NMI because NMI_EN = 1</td> </tr> </tbody> </table>	NMI_EN	GBL_SMI_EN	Description	0b	0b	No SMI# at all because GBL_SMI_EN = 0	0b	1b	SMI# will be caused due to NMI events	1b	0b	No SMI# at all because GBL_SMI_EN = 0	1b	1b	No SMI# due to NMI because NMI_EN = 1
NMI_EN	GBL_SMI_EN	Description														
0b	0b	No SMI# at all because GBL_SMI_EN = 0														
0b	1b	SMI# will be caused due to NMI events														
1b	0b	No SMI# at all because GBL_SMI_EN = 0														
1b	1b	No SMI# due to NMI because NMI_EN = 1														
8	NMI_NOW — R/WC. 0 = Software clears this bit by writing a 1 to it. The NMI handler is expected to clear this bit. Another NMI will not be generated until the bit is cleared. 1 = Writing a 1 to this bit causes an NMI. This allows the BIOS or SMI handler to force an entry to the NMI handler.															
7:0	Reserved															

10.9.7 TCO2_CNT—TCO2 Control Register

I/O Address: TCOBASE +0Ah Attribute: R/W
 Default Value: 0008h Size: 16-bit
 Lockable: No Power Well: Resume

Bit	Description
15:6	Reserved
5:4	<p>OS_POLICY — R/W. OS-based software writes to these bits to select the policy that the BIOS will use after the platform resets due the WDT. The following convention is recommended for the BIOS and OS:</p> <p>00 = Boot normally 01 = Shut down 10 = Don't load OS. Hold in pre-boot state and use LAN to determine next step 11 = Reserved</p> <p>NOTE: These are just scratchpad bits. They should not be reset when the TCO logic resets the platform due to Watchdog Timer.</p>
3	<p>GPI11_ALERT_DISABLE — R/W. At reset (via RSMRST# asserted) this bit is set and GPI[11] alerts are disabled.</p> <p>0 = Enable. 1 = Disable GPI[11]/SMBALERT# as an alert source for the heartbeats and the SMBus slave.</p>
2:1	<p>INTRD_SEL — R/W. This field selects the action to take if the INTRUDER# signal goes active.</p> <p>00 = No interrupt or SMI# 01 = Interrupt (as selected by TCO_INT_SEL). 10 = SMI 11 = Reserved</p>
0	Reserved

10.9.8 TCO_MESSAGE1 and TCO_MESSAGE2 Registers

I/O Address: TCOBASE +0Ch (Message 1) Attribute: R/W
 TCOBASE +0Dh (Message 2)
 Default Value: 00h Size: 8-bit
 Lockable: No Power Well: Resume

Bit	Description
7:0	<p>TCO_MESSAGE[n] — R/W. The value written into this register will be sent out via the SMLINK interface in the MESSAGE field of the Alert On LAN message. BIOS can write to this register to indicate its boot progress which can be monitored externally</p>

10.9.9 TCO_WDCNT—TCO Watchdog Control Register

Offset Address: TCOBASE + 0Eh Attribute: R/W
 Default Value: 00h Size: 8 bits
 Power Well: Resume

Bit	Description
7:0	Watchdog Status (WDSTATUS) — R/W. The value written to this register will be sent in the Alert On LAN message on the SMLINK interface. It can be used by the BIOS or system management software to indicate more details on the boot progress. This register will be reset to the default of 00h based on RSMRST# (but not PCI reset).

10.9.10 SW_IRQ_GEN—Software IRQ Generation Register

Offset Address: TCOBASE + 10h Attribute: R/W
 Default Value: 11h Size: 8 bits
 Power Well: Core

Bit	Description
7:2	Reserved
1	IRQ12_CAUSE — R/W. The state of this bit is logically ANDed with the IRQ12 signal as received by the ICH6's SERIRQ logic. This bit must be a 1 (default) if the ICH6 is expected to receive IRQ12 assertions from a SERIRQ device.
0	IRQ1_CAUSE — R/W. The state of this bit is logically ANDed with the IRQ1 signal as received by the ICH6's SERIRQ logic. This bit must be a 1 (default) if the ICH6 is expected to receive IRQ1 assertions from a SERIRQ device.

10.9.11 TCO_TMR—TCO Timer Initial Value Register

I/O Address: TCOBASE +12h Attribute: R/W
 Default Value: 0004h Size: 16-bit
 Lockable: No Power Well: Core

Bit	Description
15:10	Reserved
9:0	TCO Timer Initial Value — R/W. Value that is loaded into the timer each time the TCO_RLD register is written. Values of 0000h or 0001h will be ignored and should not be attempted. The timer is clocked at approximately 0.6 seconds, and thus allows timeouts ranging from 1.2 second to 613.8 seconds. Note: The timer has an error of ± 1 tick (0.6s). The TCO Timer will only count down in the S0 state.

10.10 General Purpose I/O Registers (D31:F0)

The control for the general purpose I/O signals is handled through a separate 64-byte I/O space. The base offset for this space is selected by the GPIOBASE register.

10.10.1 GPIO Register I/O Address Map

Table 10-13. Registers to Control GPIO Address Map

GPIOBASE + Offset	Mnemonic	Register Name	Default	Access
General Registers				
00–03h	GPIO_USE_SEL	GPIO Use Select	1BA83180h	R/W
04–07h	GP_IO_SEL	GPIO Input/Output Select	E400 FFFFh	R/W
08–0Bh	—	Reserved	—	—
0C–0Fh	GP_LVL	GPIO Level for Input or Output	FF3F0000h	R/W
10–13h	—	Reserved	—	—
Output Control Registers				
14–17h	—	Reserved	—	—
18–1Bh	GPO_BLINK	GPIO Blink Enable	00040000h	R/W
1C–1Fh	—	Reserved	—	—
Input Control Registers				
20–2Bh	—	Reserved	—	—
2C–2Fh	GPI_INV	GPIO Signal Invert	00000000h	R/W
30–33h	GPIO_USE_SEL2	GPIO Use Select 2 [63:32]	00000006h	R/W
34–37h	GP_IO_SEL2	GPIO Input/Output Select 2 [63:32]	00000300h	R/W
38–3Bh	GP_LVL2	GPIO Level for Input or Output 2 [63:32]	00030207h	R/W

10.10.2 GPIO_USE_SEL—GPIO Use Select Register

Offset Address:	GPIOBASE + 00h	Attribute:	R/W
Default Value:	1BA83180h	Size:	32-bit
Lockable:	No	Power Well:	Core for 0:7, 12, 16:21, 23, 26, 29:31 Resume for 8:11, 13:15, 25, 27, 28

Bit	Description
31:29, 26, 15:14, 11:9, 5:0	<p>GPIO_USE_SEL[31:29, 26, 15:14, 11:9, 5:0] — R/W. Each bit in this register enables the corresponding GPIO (if it exists) to be used as a GPIO, rather than for the native function.</p> <p>0 = Signal used as native function. 1 = Signal used as a GPIO.</p> <p>NOTES:</p> <ol style="list-style-type: none"> The following bit is not implemented because there is no corresponding GPIO: 22. The following bits are always 1 because they are unmultiplexed: 7, 8, 12:13, 19, 21, 23:25, 27:28 The following bits are not implemented because they are determined by the Desktop/Mobile configuration: 6, 18, 20 Bit 16 is not implemented because GPO selection will be controlled by Bit 0 (REQ/GNT pair) Bit 17 is not implemented because GPO selection will be controlled by Bit 1 (REQ/GNT pair) If GPIO[n] does not exist, then the bit in this register will always read as 0 and writes will have no effect. After a full reset (RSMRST#) all multiplexed signals in the resume and core wells are configured as their native function rather than as a GPIO. After just a PLTRST#, the GPIO in the core well are configured as their native function. When configured to GPIO mode, the multiplexing logic should present the inactive state to native logic that uses the pin as an input.

10.10.3 GP_IO_SEL—GPIO Input/Output Select Register

Offset Address:	GPIOBASE +04h	Attribute:	R/W
Default Value:	E400FFFFh	Size:	32-bit
Lockable:	No	Power Well:	Resume

Bit	Description
31:29	Always 1. These GPIs are fixed as inputs.
28:27	<p>GP_IO_SEL[28:27] — R/W. When set to a 1, the corresponding GPIO signal (if enabled in the GPIO_USE_SEL register) is programmed as an input. When set to 0, the GPIO signal is programmed as an output.</p> <p>0 = Output. The corresponding GPIO signal is an output. 1 = Input. The corresponding GPIO signal is an input.</p>
26	Always 1. This GPI is fixed as an input.
25:24	<p>GP_IO_SEL[25:24] — R/W. When set to a 1, the corresponding GPIO signal (if enabled in the GPIO_USE_SEL register) is programmed as an input. When set to 0, the GPIO signal is programmed as an output.</p> <p>0 = Output. The corresponding GPIO signal is an output. 1 = Input. The corresponding GPIO signal is an input.</p>
21:16	Always 0. The GPOs are fixed as outputs.
15:0	Always 1. These GPIs are fixed as inputs.

10.10.4 GP_LVL—GPIO Level for Input or Output Register

Offset Address:	GPIOBASE +0Ch	Attribute:	R/W
Default Value:	FF3F0000h	Size:	32-bit
Lockable:	No	Power Well:	See bit descriptions

Bit	Description
31:29	<p>GP_LVL[31:29] — R/W. These bits correspond to input-only GPI in the core well. The corresponding GP_LVL bit reflects the state of the input signal (1 = high, 0 = low). Writes to these bits will have no effect.</p> <p>Since these bits correspond to GPI that are in the core well, these bits will be reset by PLTRST#.</p> <p>0 = Low 1 = High</p>
28:27	<p>GP_LVL[28:27] — R/W. If GPIO[n] is programmed to be an output (via the corresponding bit in the GP_IO_SEL register), then the corresponding GP_LVL[n] bit can be updated by software to drive a high or low value on the output pin. 1 = high, 0 = low.</p> <p>If GPIO[n] is programmed as an input, then the corresponding GP_LVL bit reflects the state of the input signal (1 = high, 0 = low.). Writes will have no effect.</p> <p>Since these bits correspond to GPIO that are in the Resume well, these bits will be reset by RSMRST# and also by a write to the CF9h register.</p> <p>0 = Low 1 = High</p>
26	<p>GP_LVL[26] — R/W. This bit corresponds to an input-only GPI in the core well. The corresponding GP_LVL bit reflects the state of the input signal (1 = high, 0 = low). Writes to this bit will have no effect.</p> <p>Since this bit correspond to a GPI that is in the core well, this bit will be reset by PLTRST#.</p> <p>0 = Low 1 = High</p>
25:24	<p>GP_LVL[25:24] — R/W. If GPIO[n] is programmed to be an output (via the corresponding bit in the GP_IO_SEL register), then the corresponding GP_LVL[n] bit can be updated by software to drive a high or low value on the output pin. 1 = high, 0 = low.</p> <p>If GPIO[n] is programmed as an input, then the corresponding GP_LVL bit reflects the state of the input signal (1 = high, 0 = low.). Writes will have no effect.</p> <p>Since these bits correspond to GPIO that are in the Resume well, these bits will be reset by RSMRST# and also by a write to the CF9h register.</p> <p>0 = Low 1 = High</p>
23:16	<p>GP_LVL[23:16] — R/W. These bits can be updated by software to drive a high or low value on the output pin. These bits correspond to GPIO that are in the core well, and will be reset to their default values by PLTRST#.</p> <p>0 = Low 1 = High</p>
15:0	Reserved. (These bits are not needed, as the level of general purpose inputs can be read through the registers in the ACPI I/O space).

10.10.5 GPO_BLINK—GPO Blink Enable Register

Offset Address:	GPIOBASE +18h	Attribute:	R/W
Default Value:	0004 0000h	Size:	32-bit
Lockable:	No	Power Well:	See bit description

Bit	Description
28:27, 25	<p>GP_BLINK[28:27, 25] — R/W. The setting of this bit has no effect if the corresponding GPIO signal is programmed as an input.</p> <p>0 = The corresponding GPIO will function normally. 1 = If the corresponding GPIO is programmed as an output, the output signal will blink at a rate of approximately once per second. The high and low times have approximately 0.5 seconds each. The GP_LVL bit is not altered when this bit is set.</p> <p>The value of the corresponding GP_LVL bit remains unchanged during the blink process, and does not effect the blink in any way. The GP_LVL bit is not altered when programmed to blink. It will remain at its previous value.</p> <p>These bits correspond to GPIO in the Resume well. These bits revert to the default value based on RSMRST# or a write to the CF9h register (but not just on PLTRST#).</p>
19:18 (Desktop Only)	<p>GP_BLINK[n] — R/W. The setting of these bits will have no effect if the corresponding GPIO is programmed as an input. These bits correspond to GPIO that are in the Core well, and will be reset to their default values by PLTRST#.</p> <p>0 = The corresponding GPIO will function normally. 1 = If the corresponding GPIO is programmed as an output, the output signal will blink at a rate of approximately once per second. The high and low times are approximately 0.5 seconds each. The GP_LVL bit is not altered when this bit is set.</p>
19 (Mobile Only)	<p>GP_BLINK[n] — R/W. The setting of these bits will have no effect if the corresponding GPIO is programmed as an input. These bits correspond to GPIO that are in the Core well, and will be reset to their default values by PLTRST#.</p> <p>0 = The corresponding GPIO will function normally. 1 = If the corresponding GPIO is programmed as an output, the output signal will blink at a rate of approximately once per second. The high and low times are approximately 0.5 seconds each. The GP_LVL bit is not altered when this bit is set.</p>

NOTE: (Desktop Only) GPIO18 will blink by default immediately after reset. This signal could be connected to an LED to indicate a failed boot (by programming BIOS to clear GP_BLINK18 after successful POST).

10.10.6 GPI_INV—GPIO Signal Invert Register

Offset Address: GPIOBASE +2Ch Attribute: R/W
 Default Value: 00000000h Size: 32-bit
 Lockable: No Power Well: See bit description

Bit	Description
31:16	Reserved
15:13	<p>GP_INV[n] — R/W. These bits are used to allow both active-low and active-high inputs to cause SMI# or SCI. Note that in the S0 or S1 state, the input signal must be active for at least two PCI clocks to ensure detection by the ICH6. In the S3, S4 or S5 states the input signal must be active for at least 2 RTC clocks to ensure detection. The setting of these bits has no effect if the corresponding GPIO is programmed as an output. These bits correspond to GPI that are in the resume well, and will be reset to their default values by RSMRST# or by a write to the CF9h register.</p> <p>0 = The corresponding GPI_STS bit is set when the ICH6 detects the state of the input pin to be high. 1 = The corresponding GPI_STS bit is set when the ICH6 detects the state of the input pin to be low.</p>
12	<p>GP_INV[n] — R/W. These bits are used to allow both active-low and active-high inputs to cause SMI# or SCI. Note that in the S0 or S1 state, the input signal must be active for at least two PCI clocks to ensure detection by the ICH6. These bits correspond to GPI that are in the core well, and will be reset to their default values by PLTRST#.</p> <p>0 = The corresponding GPI_STS bit is set when the ICH6 detects the state of the input pin to be high. 1 = The corresponding GPI_STS bit is set when the ICH6 detects the state of the input pin to be low.</p>
11:8	<p>GP_INV[n] — R/W. These bits are used to allow both active-low and active-high inputs to cause SMI# or SCI. Note that in the S0 or S1 state, the input signal must be active for at least two PCI clocks to ensure detection by the ICH6. In the S3, S4 or S5 states the input signal must be active for at least 2 RTC clocks to ensure detection. The setting of these bits has no effect if the corresponding GPIO is programmed as an output. These bits correspond to GPI that are in the resume well, and will be reset to their default values by RSMRST# or by a write to the CF9h register.</p> <p>0 = The corresponding GPI_STS bit is set when the ICH6 detects the state of the input pin to be high. 1 = The corresponding GPI_STS bit is set when the ICH6 detects the state of the input pin to be low.</p>
7:0	<p>GP_INV[n] — R/W. These bits are used to allow both active-low and active-high inputs to cause SMI# or SCI. Note that in the S0 or S1 state, the input signal must be active for at least two PCI clocks to ensure detection by the ICH6. The setting of these bits will have no effect if the corresponding GPIO is programmed as an output. These bits correspond to GPI that are in the core well, and will be reset to their default values by PLTRST#.</p> <p>0 = The corresponding GPI_STS bit is set when the ICH6 detects the state of the input pin to be high. 1 = The corresponding GPI_STS bit is set when the ICH6 detects the state of the input pin to be low.</p>

10.10.7 GPIO_USE_SEL2—GPIO Use Select 2 Register[63:32]

Offset Address:	GPIOBASE +30h	Attribute:	R/W
Default Value:	00000006h	Size:	32-bit
Lockable:	No	Power Well:	Processor I/O for 17, Core for 16:0

Bit	Description
17, 9:8	<p>GPIO_USE_SEL2[49, 41:40] — R/W. Each bit in this register enables the corresponding GPIO (if it exists) to be used as a GPIO, rather than for the native function.</p> <p>0 = Signal used as native function. 1 = Signal used as a GPIO.</p> <p>After a full reset (RSMRST#) all multiplexed signals in the resume and core wells are configured as a GPIO rather than as their native function. After just a PLTRST#, the GPIO in the core well are configured as GPIO.</p> <p>NOTES:</p> <ol style="list-style-type: none"> The following bits are not implemented because there is no corresponding GPIO: 3:7, 10:15, 18:31. The following bits are always 1 because they are unmultiplexed: 1:2 Bit 16 is not implemented because the GPIO selection will be controlled by Bit 8 (REQ/GNT pair) If GPIO[n] does not exist, then the bit in this register will always read as 0 and writes will have no effect. The following bits are not implemented because they are determined by the Desktop/Mobile configuration: 0

10.10.8 GP_IO_SEL2—GPIO Input/Output Select 2 Register[63:32]

Offset Address:	GPIOBASE +34h	Attribute:	R/W
Default Value:	00000300h	Size:	32-bit
Lockable:	No	Power Well:	Core

Bit	Description
31:18	Always 0. No corresponding GPIO.
17:16	Always 0. Outputs.
15:10	Always 0. No corresponding GPIO.
9:8	Always 0. Inputs.
7:3	Always 0. No corresponding GPIO.
2:0	<p>GP_IO_SEL2[34:32] — R/W.</p> <p>0 = GPIO signal is programmed as an output. 1 = Corresponding GPIO signal (if enabled in the GPIO_USE_SEL2 register) is programmed as an input.</p>

10.10.9 GP_LVL2—GPIO Level for Input or Output 2 Register[63:32]

Offset Address: GPIOBASE +38h Attribute: R/W
 Default Value: 00030207h Size: 32-bit
 Lockable: No Power Well: See below

Bit	Description
31:18	Reserved. Read-only 0
17:16	GP_LVL[49:48] — R/W. The corresponding GP_LVL[n] bit can be updated by software to drive a high or low value on the output pin. Since these bits correspond to GPIO that are in the processor I/O and core well, respectively, these bits will be reset by PLTRST#. 0 = low 1 = high
15:10	Reserved. Read-only 0
9:8	GP_LVL[41:40] — R/W. The corresponding GP_LVL[n] bit reflects the state of the input signal. Writes will have no effect. Since these bits correspond to GPIO that are in the core well, these bits will be reset by PLTRST#. 0 = low 1 = high
7:3	Reserved. Read-only 0
2:0	GP_LVL[34:32] — R/W. If GPIO _n is programmed to be an output (via the corresponding bit in the GP_IO_SEL register), then the corresponding GP_LVL[n] bit can be updated by software to drive a high or low value on the output pin. If GPIO _n is programmed as an input, then the corresponding GP_LVL bit reflects the state of the input signal (1 = high, 0 = low). Writes will have no effect. 0 = low 1 = high Since these bits correspond to GPIO that are in the core well, these bits will be reset by PLTRST#.

§

11 IDE Controller Registers (D31:F1)

11.1 PCI Configuration Registers (IDE—D31:F1)

Note: Address locations that are not shown should be treated as Reserved (See Section 6.2 for details).

All of the IDE registers are in the core well. None of the registers can be locked.

Table 11-1. IDE Controller PCI Register Address Map (IDE-D31:F1)

Offset	Mnemonic	Register Name	Default	Type
00–01h	VID	Vendor Identification	8086h	RO
02–03h	DID	Device Identification	266Fh	RO
04–05h	PCICMD	PCI Command	00h	R/W, RO
06–07h	PCISTS	PCI Status	0280h	R/W, RO
08h	RID	Revision Identification	See register description.	RO
09h	PI	Programming Interface	8Ah	R/W, RO
0Ah	SCC	Sub Class Code	01h	RO
0Bh	BCC	Base Class Code	01h	RO
0Ch	CLS	Cache Line Size	00h	RO
0Dh	PMLT	Primary Master Latency Timer	00h	RO
10–13h	PCMD_BAR	Primary Command Block Base Address	00000001h	R/W, RO
14–17h	PCNL_BAR	Primary Control Block Base Address	00000001h	R/W, RO
18–1Bh	SCMD_BAR	Secondary Command Block Base Address	00000001h	R/W, RO
1C–1Fh	SCNL_BAR	Secondary Control Block Base Address	00000001h	R/W, RO
20–23h	BM_BASE	Bus Master Base Address	00000001h	R/W, RO
2C–2Dh	IDE_SVID	Subsystem Vendor ID	00h	R/WO
2E–2Fh	IDE_SID	Subsystem ID	0000h	R/WO
3C	INTR_LN	Interrupt Line	See register description.	R/W
3D	INTR_PN	Interrupt Pin	01h	RO
40–41h	IDE_TIMP	Primary IDE Timing	0000h	R/W
42–43h	IDE_TIMS	Secondary IDE Timing	0000h	R/W
44h	SLV_IDETIM	Slave IDE Timing	00h	R/W
48h	SDMA_CNT	Synchronous DMA Control	00h	R/W
4A–4Bh	SDMA_TIM	Synchronous DMA Timing	0000h	R/W
54h	IDE_CONFIG	IDE I/O Configuration	00000000h	R/W
C0h	ATC	APM Trapping Control	00h	R/W
C4h	ATS	APM Trapping Status	00h	R/WC

NOTE: The ICH6 IDE controller is not arbitrated as a PCI device; therefore, it does not need a master latency

timer.

11.1.1 VID—Vendor Identification Register (IDE—D31:F1)

Offset Address:	00–01h	Attribute:	RO
Default Value:	8086h	Size:	16-bit
Lockable:	No	Power Well:	Core

Bit	Description
15:0	Vendor ID — RO. This is a 16-bit value assigned to Intel. Intel VID = 8086h

11.1.2 DID—Device Identification Register (IDE—D31:F1)

Offset Address:	02–03h	Attribute:	RO
Default Value:	266Fh	Size:	16-bit
Lockable:	No	Power Well:	Core

Bit	Description
15:0	Device ID — RO. This is a 16-bit value assigned to the ICH6 IDE controller.

11.1.3 PCICMD—PCI Command Register (IDE—D31:F1)

Address Offset: 04h–05h Attribute: RO, R/W
Default Value: 00h Size: 16 bits

Bit	Description
15:11	Reserved
10	Interrupt Disable (ID) — R/W. 0 = Enables the IDE controller to assert INTA# (native mode) or IRQ14/15 (legacy mode). 1 = Disable. The interrupt will be de-asserted.
9	Fast Back to Back Enable (FBE) — RO. Reserved as 0.
8	SERR# Enable (SERR_EN) — RO. Reserved as 0.
7	Wait Cycle Control (WCC) — RO. Reserved as 0.
6	Parity Error Response (PER) — RO. Reserved as 0.
5	VGA Palette Snoop (VPS) — RO. Reserved as 0.
4	Postable Memory Write Enable (PMWE) — RO. Reserved as 0.
3	Special Cycle Enable (SCE) — RO. Reserved as 0.
2	Bus Master Enable (BME) — R/W. Controls the ICH6’s ability to act as a PCI master for IDE Bus Master transfers.
1	Memory Space Enable (MSE) — R/W. 0 = Disables access. 1 = Enables access to the IDE Expansion memory range. The EXBAR register (Offset 24h) must be programmed before this bit is set. NOTE: BIOS should set this bit to a 1.
0	I/O Space Enable (IOSE) — R/W. This bit controls access to the I/O space registers. 0 = Disables access to the Legacy or Native IDE ports (both Primary and Secondary) as well as the Bus Master I/O registers. 1 = Enable. Note that the Base Address register for the Bus Master registers should be programmed before this bit is set. NOTES: 1. Separate bits are provided (IDE Decode Enable, in the IDE Timing register) to independently disable the Primary or Secondary I/O spaces. 2. When this bit is 0 and the IDE controller is in Native Mode, the Interrupt Pin Register (see Section 11.1.19) will be masked (the interrupt will not be asserted). If an interrupt occurs while the masking is in place and the interrupt is still active when the masking ends, the interrupt will be allowed to be asserted.

11.1.4 PCISTS — PCI Status Register (IDE—D31:F1)

Address Offset: 06–07h Attribute: R/WC, RO
 Default Value: 0280h Size: 16 bits

Note: For the writable bits, software must write a 1 to clear bits that are set. Writing a 0 to the bit has no effect.

Bit	Description
15	Detected Parity Error (DPE) — RO. Reserved as 0.
14	Signaled System Error (SSE) — RO. Reserved as 0.
13	Received Master Abort (RMA) — R/WC. 0 = Master abort Not generated by Bus Master IDE interface function. 1 = Bus Master IDE interface function, as a master, generated a master abort.
12	Reserved as 0 — RO.
11	Reserved as 0 — RO.
10:9	DEVSEL# Timing Status (DEV_STS) — RO. 01 = Hardwired; however, the ICH6 does not have a real DEVSEL# signal associated with the IDE unit, so these bits have no effect.
8	Data Parity Error Detected (DPED) — RO. Reserved as 0.
7	Fast Back to Back Capable (FB2BC) — RO. Reserved as 1.
6	User Definable Features (UDF) — RO. Reserved as 0.
5	66MHz Capable (66MHZ_CAP) — RO. Reserved as 0.
4	Reserved
3	Interrupt Status (INTS) — RO. This bit is independent of the state of the Interrupt Disable bit in the command register. 0 = Interrupt is cleared. 1 = Interrupt/MSI is asserted. NOTE: This bit will read '1' after Power On Reset when no parallel ATA drive is attached. This is the intended behavior.
2:0	Reserved

11.1.5 RID—Revision Identification Register (IDE—D31:F1)

Offset Address: 08h Attribute: RO
 Default Value: See bit description Size: 8 bits

Bit	Description
7:0	Revision ID — RO. Refer to the <i>Intel® I/O Controller Hub 6 (ICH6) Family Specification Update</i> for the value of the Revision ID Register

11.1.6 PI—Programming Interface Register (IDE—D31:F1)

Address Offset: 09h Attribute: RO, R/W
 Default Value: 8Ah Size: 8 bits

Bit	Description
7	This read-only bit is a 1 to indicate that the ICH6 supports bus master operation
6:4	Reserved. Hardwired to 000b.
3	SOP_MODE_CAP — RO. This read-only bit is a 1 to indicate that the secondary controller supports both legacy and native modes.
2	SOP_MODE_SEL — R/W. This read/write bit determines the mode that the secondary IDE channel is operating in. 0 = Legacy-PCI mode (default) 1 = Native-PCI mode
1	POP_MODE_CAP — RO. This read-only bit is a 1 to indicate that the primary controller supports both legacy and native modes.
0	POP_MODE_SEL — R/W. This read/write bits determines the mode that the primary IDE channel is operating in. 0 = Legacy-PCI mode (default) 1 = Native-PCI mode

11.1.7 SCC—Sub Class Code Register (IDE—D31:F1)

Address Offset: 0Ah Attribute: RO
 Default Value: 01h Size: 8 bits

Bit	Description
7:0	Sub Class Code (SCC) — RO. 01h = IDE device, in the context of a mass storage device.



11.1.12 PCNL_BAR—Primary Control Block Base Address Register (IDE—D31:F1)

Address Offset: 14h–17h Attribute: R/W, RO
Default Value: 00000001h Size: 32 bits

Bit	Description
31:16	Reserved
15:2	Base Address — R/W. Base address of the I/O space (4 consecutive I/O locations).
1	Reserved
0	Resource Type Indicator (RTE) — RO. Hardwired to 1 indicating a request for I/O space.

NOTE: This 4-byte I/O space is used in native mode for the Primary Controller's Command Block.

11.1.13 SCMD_BAR—Secondary Command Block Base Address Register (IDE D31:F1)

Address Offset: 18h–1Bh Attribute: R/W, RO
Default Value: 00000001h Size: 32 bits

Bit	Description
31:16	Reserved
15:3	Base Address — R/W. Base address of the I/O space (8 consecutive I/O locations).
2:1	Reserved
0	Resource Type Indicator (RTE) — RO. Hardwired to 1 indicating a request for I/O space.

NOTE: This 4-byte I/O space is used in native mode for the Secondary Controller's Command Block.

11.1.14 SCNL_BAR—Secondary Control Block Base Address Register (IDE D31:F1)

Address Offset: 1Ch–1Fh Attribute: R/W, RO
Default Value: 00000001h Size: 32 bits

Bit	Description
31:16	Reserved
15:2	Base Address — R/W. Base address of the I/O space (4 consecutive I/O locations).
1	Reserved
0	Resource Type Indicator (RTE) — RO. Hardwired to 1 indicating a request for I/O space.

NOTE: This 4-byte I/O space is used in native mode for the Secondary Controller's Command Block.



11.1.18 INTR_LN—Interrupt Line Register (IDE—D31:F1)

Address Offset: 3Ch Attribute: R/W
Default Value: 00h Size: 8 bits

Bit	Description
7:0	Interrupt Line (INTR_LN) — R/W. This field is used to communicate to software the interrupt line that the interrupt pin is connected to.

11.1.19 INTR_PN—Interrupt Pin Register (IDE—D31:F1)

Address Offset: 3Dh Attribute: RO
Default Value: See Register Description Size: 8 bits

Bit	Description
7:0	Interrupt Pin — RO. This field reflects the value of D31IP.PIP (Chipset Configuration Registers:Offset 3100h:bits 7:4).

11.1.20 IDE_TIMP — IDE Primary Timing Register (IDE—D31:F1)

Address Offset: 40–41h Attribute: R/W
Default Value: 0000h Size: 16 bits

This register controls the timings driven on the IDE cable for PIO and 8237 style DMA transfers. It also controls operation of the buffer for PIO transfers.

Bit	Description
15	IDE Decode Enable (IDE) — R/W. The IDE I/O Space Enable bit (D31:F1:04h, bit 0) in the Command register must be set in order for this bit to have any effect. 0 = Disable. 1 = Enables the ICH6 to decode the Command (1F0–1F7h) and Control (3F6h) Blocks. This bit also effects the memory decode range for IDE Expansion.
14	Drive 1 Timing Register Enable (SITRE) — R/W. 0 = Use bits 13:12, 9:8 for both drive 0 and drive 1. 1 = Use bits 13:12, 9:8 for drive 0, and use the Slave IDE Timing register for drive 1
13:12	IORDY Sample Point (ISP) — R/W. The setting of these bits determine the number of PCI clocks between IDE IOR#/IOW# assertion and the first IORDY sample point. 00 = 5 clocks 01 = 4 clocks 10 = 3 clocks 11 = Reserved
11:10	Reserved
9:8	Recovery Time (RCT) — R/W. The setting of these bits determines the minimum number of PCI clocks between the last IORDY sample point and the IOR#/IOW# strobe of the next cycle. 00 = 4 clocks 01 = 3 clocks 10 = 2 clocks 11 = 1 clock

Bit	Description
7	Drive 1 DMA Timing Enable (DTE1) — R/W. 0 = Disable. 1 = Enable the fast timing mode for DMA transfers only for this drive. PIO transfers to the IDE data port will run in compatible timing.
6	Drive 1 Prefetch/Posting Enable (PPE1) — R/W. 0 = Disable. 1 = Enable Prefetch and posting to the IDE data port for this drive.
5	Drive 1 IORDY Sample Point Enable (IE1) — R/W. 0 = Disable IORDY sampling for this drive. 1 = Enable IORDY sampling for this drive.
4	Drive 1 Fast Timing Bank (TIME1) — R/W. 0 = Accesses to the data port will use compatible timings for this drive. 1 = When this bit = 1 and bit 14 = 0, accesses to the data port will use bits 13:12 for the IORDY sample point, and bits 9:8 for the recovery time. When this bit = 1 and bit 14 = 1, accesses to the data port will use the IORDY sample point and recover time specified in the slave IDE timing register.
3	Drive 0 DMA Timing Enable (DTE0) — R/W. 0 = Disable 1 = Enable fast timing mode for DMA transfers only for this drive. PIO transfers to the IDE data port will run in compatible timing.
2	Drive 0 Prefetch/Posting Enable (PPE0) — R/W. 0 = Disable prefetch and posting to the IDE data port for this drive. 1 = Enable prefetch and posting to the IDE data port for this drive.
1	Drive 0 IORDY Sample Point Enable (IE0) — R/W. 0 = Disable IORDY sampling is disabled for this drive. 1 = Enable IORDY sampling for this drive.
0	Drive 0 Fast Timing Bank (TIME0) — R/W. 0 = Accesses to the data port will use compatible timings for this drive. 1 = Accesses to the data port will use bits 13:12 for the IORDY sample point, and bits 9:8 for the recovery time

11.1.23 SDMA_CNT—Synchronous DMA Control Register (IDE—D31:F1)

Address Offset: 48h
Default Value: 00h

Attribute: R/W
Size: 8 bits

Bit	Description
7:4	Reserved
3:2	No Operation (NOP) — R/W. These bits are read/write for legacy software compatibility, but have no functionality in the ICH6.
1	Primary Drive 1 Synchronous DMA Mode Enable (PSDE1) — R/W. 0 = Disable (default) 1 = Enable Synchronous DMA mode for primary channel drive 1.
0	Primary Drive 0 Synchronous DMA Mode Enable (PSDE0) — R/W. 0 = Disable (default) 1 = Enable Synchronous DMA mode for primary channel drive 0.

11.1.24 SDMA_TIM—Synchronous DMA Timing Register (IDE—D31:F1)

Address Offset: 4A–4Bh
 Default Value: 0000h

Attribute: R/W
 Size: 16 bits

Note: For FAST_PCB1 = 1 (133 MHz clk) in bits [13:12, 9:8, 5:4, 1:0], refer to [Section 5.16.4](#) for details.

Bit	Description															
15:14	Reserved															
13:12	No Operation (NOP) — R/W. These bits are read/write for legacy software compatibility, but have no functionality in the ICH6.															
11:10	Reserved															
9:8	No Operation (NOP) — R/W. These bits are read/write for legacy software compatibility, but have no functionality in the ICH6.															
7:6	Reserved															
5:4	<p>Primary Drive 1 Cycle Time (PCT1) — R/W. For Ultra ATA mode, the setting of these bits determines the minimum write strobe cycle time (CT). The DMARDY#-to-STOP (RP) time is also determined by the setting of these bits.</p> <table border="0"> <thead> <tr> <th>PCB1 = 0 (33 MHz clk)</th> <th>PCB1 = 1 (66 MHz clk)</th> <th>FAST_PCB1 = 1 (133 MHz clk)</th> </tr> </thead> <tbody> <tr> <td>00 = CT 4 clocks, RP 6 clocks</td> <td>00 = Reserved</td> <td>00 = Reserved</td> </tr> <tr> <td>01 = CT 3 clocks, RP 5 clocks</td> <td>01 = CT 3 clocks, RP 8 clocks</td> <td>01 = CT 3 clocks, RP 16 clocks</td> </tr> <tr> <td>10 = CT 2 clocks, RP 4 clocks</td> <td>10 = CT 2 clocks, RP 8 clocks</td> <td>10 = Reserved</td> </tr> <tr> <td>11 = Reserved</td> <td>11 = Reserved</td> <td>11 = Reserved</td> </tr> </tbody> </table>	PCB1 = 0 (33 MHz clk)	PCB1 = 1 (66 MHz clk)	FAST_PCB1 = 1 (133 MHz clk)	00 = CT 4 clocks, RP 6 clocks	00 = Reserved	00 = Reserved	01 = CT 3 clocks, RP 5 clocks	01 = CT 3 clocks, RP 8 clocks	01 = CT 3 clocks, RP 16 clocks	10 = CT 2 clocks, RP 4 clocks	10 = CT 2 clocks, RP 8 clocks	10 = Reserved	11 = Reserved	11 = Reserved	11 = Reserved
PCB1 = 0 (33 MHz clk)	PCB1 = 1 (66 MHz clk)	FAST_PCB1 = 1 (133 MHz clk)														
00 = CT 4 clocks, RP 6 clocks	00 = Reserved	00 = Reserved														
01 = CT 3 clocks, RP 5 clocks	01 = CT 3 clocks, RP 8 clocks	01 = CT 3 clocks, RP 16 clocks														
10 = CT 2 clocks, RP 4 clocks	10 = CT 2 clocks, RP 8 clocks	10 = Reserved														
11 = Reserved	11 = Reserved	11 = Reserved														
3:2	Reserved															
1:0	<p>Primary Drive 0 Cycle Time (PCT0) — R/W. For Ultra ATA mode, the setting of these bits determines the minimum write strobe cycle time (CT). The DMARDY#-to-STOP (RP) time is also determined by the setting of these bits.</p> <table border="0"> <thead> <tr> <th>PCB1 = 0 (33 MHz clk)</th> <th>PCB1 = 1 (66 MHz clk)</th> <th>FAST_PCB1 = 1 (133 MHz clk)</th> </tr> </thead> <tbody> <tr> <td>00 = CT 4 clocks, RP 6 clocks</td> <td>00 = Reserved</td> <td>00 = Reserved</td> </tr> <tr> <td>01 = CT 3 clocks, RP 5 clocks</td> <td>01 = CT 3 clocks, RP 8 clocks</td> <td>01 = CT 3 clocks, RP 16 clocks</td> </tr> <tr> <td>10 = CT 2 clocks, RP 4 clocks</td> <td>10 = CT 2 clocks, RP 8 clocks</td> <td>10 = Reserved</td> </tr> <tr> <td>11 = Reserved</td> <td>11 = Reserved</td> <td>11 = Reserved</td> </tr> </tbody> </table>	PCB1 = 0 (33 MHz clk)	PCB1 = 1 (66 MHz clk)	FAST_PCB1 = 1 (133 MHz clk)	00 = CT 4 clocks, RP 6 clocks	00 = Reserved	00 = Reserved	01 = CT 3 clocks, RP 5 clocks	01 = CT 3 clocks, RP 8 clocks	01 = CT 3 clocks, RP 16 clocks	10 = CT 2 clocks, RP 4 clocks	10 = CT 2 clocks, RP 8 clocks	10 = Reserved	11 = Reserved	11 = Reserved	11 = Reserved
PCB1 = 0 (33 MHz clk)	PCB1 = 1 (66 MHz clk)	FAST_PCB1 = 1 (133 MHz clk)														
00 = CT 4 clocks, RP 6 clocks	00 = Reserved	00 = Reserved														
01 = CT 3 clocks, RP 5 clocks	01 = CT 3 clocks, RP 8 clocks	01 = CT 3 clocks, RP 16 clocks														
10 = CT 2 clocks, RP 4 clocks	10 = CT 2 clocks, RP 8 clocks	10 = Reserved														
11 = Reserved	11 = Reserved	11 = Reserved														

11.1.25 IDE_CONFIG—IDE I/O Configuration Register (IDE—D31:F1)

Address Offset: 54h
Default Value: 00000000h

Attribute: R/W
Size: 32 bits

Bit	Description
31:24	Reserved
23:20	Miscellaneous Scratchpad (MS) — R/W. Previously defined as a scratchpad bit to indicate to a driver that ATA-100 is supported. This is not used by software as all they needed to know was located in bits 7:4. See the definition of those bits.
19:18	No Operation (NOP) — R/W. These bits are read/write for legacy software compatibility, but have no functionality in the ICH6.
17:16	SIG_MODE — R/W. These bits are used to control mode of the IDE signal pins for swap bay support. If the PRS bit (Chipset Configuration Registers:Offset 3414h:bit 1) is 1, the reset states of bits 17:16 will be 01 (tri-state) instead of 00 (normal). 00 = Normal (Enabled) 01 = Tri-state (Disabled) 10 = Drive low (Disabled) 11 = Reserved
15:14	No Operation (NOP) — R/W. These bits are read/write for legacy software compatibility, but have no functionality in the ICH6.
13	Fast Primary Drive 1 Base Clock (FAST_PCB1) — R/W. This bit is used in conjunction with the PCT1 bits to enable/disable Ultra ATA/100 timings for the Primary Slave drive. 0 = Disable Ultra ATA/100 timing for the Primary Slave drive. 1 = Enable Ultra ATA/100 timing for the Primary Slave drive (overrides bit 1 in this register).
12	Fast Primary Drive 0 Base Clock (FAST_PCB0) — R/W. This bit is used in conjunction with the PCT0 bits to enable/disable Ultra ATA/100 timings for the Primary Master drive. 0 = Disable Ultra ATA/100 timing for the Primary Master drive. 1 = Enable Ultra ATA/100 timing for the Primary Master drive (overrides bit 0 in this register).
11:8	Reserved
7	No Operation (NOP) — R/W. These bits are read/write for legacy software compatibility, but have no functionality in the ICH6.
6	No Operation (NOP) — R/W. These bits are read/write for legacy software compatibility, but have no functionality in the ICH6.
5	Primary Slave Channel Cable Reporting — R/W. BIOS should program this bit to tell the IDE driver which cable is plugged into the channel. 0 = 40 conductor cable is present. 1 = 80 conductor cable is present.
4	Primary Master Channel Cable Reporting — R/W. Same description as bit 5
3:2	No Operation (NOP) — R/W. These bits are read/write for legacy software compatibility, but have no functionality in the ICH6.
1	Primary Drive 1 Base Clock (PCB1) — R/W. 0 = 33 MHz base clock for Ultra ATA timings. 1 = 66 MHz base clock for Ultra ATA timings
0	Primary Drive 0 Base Clock (PCB0) — R/W. 0 = 33 MHz base clock for Ultra ATA timings. 1 = 66 MHz base clock for Ultra ATA timings

11.2.1 BMICP—Bus Master IDE Command Register (IDE—D31:F1)

Address Offset: BMIBASE + 00h Attribute: R/W
 Default Value: 00h Size: 8 bits

Bit	Description
7:4	Reserved. Returns 0.
3	<p>Read / Write Control (RWC) — R/W. This bit sets the direction of the bus master transfer: This bit must NOT be changed when the bus master function is active.</p> <p>0 = Memory reads 1 = Memory writes</p>
2:1	Reserved. Returns 0.
0	<p>Start/Stop Bus Master (START) — R/W.</p> <p>0 = All state information is lost when this bit is cleared. Master mode operation cannot be stopped and then resumed. If this bit is reset while bus master operation is still active (i.e., the Bus Master IDE Active bit (BMIBASE + 02h, bit 0) of the Bus Master IDE Status register for that IDE channel is set) and the drive has not yet finished its data transfer (the Interrupt bit (BMIBASE + 02h, bit 2) in the Bus Master IDE Status register for that IDE channel is not set), the bus master command is said to be aborted and data transferred from the drive may be discarded instead of being written to system memory.</p> <p>1 = Enables bus master operation of the controller. Bus master operation does not actually start unless the Bus Master Enable bit (D31:F1:04h, bit 2) in PCI configuration space is also set. Bus master operation begins when this bit is detected changing from 0 to 1. The controller will transfer data between the IDE device and memory only when this bit is set. Master operation can be halted by writing a 0 to this bit.</p> <p>NOTE: This bit is intended to be cleared by software after the data transfer is completed, as indicated by either the Bus Master IDE Active bit being cleared or the Interrupt bit of the Bus Master IDE Status register for that IDE channel being set, or both. Hardware does not clear this bit automatically.</p>

11.2.2 BMISP—Bus Master IDE Status Register (IDE—D31:F1)

Address Offset: BMIBASE + 02h Attribute: R/WC
 Default Value: 00h Size: 8 bits

Bit	Description
7	PRD Interrupt Status (PRDIS) — R/WC. 0 = When this bit is cleared by software, the interrupt is cleared. 1 = Set when the host controller completes execution of a PRD that has its Interrupt bit (bit 2 of this register) set.
6	Drive 1 DMA Capable — R/W. 0 = Not Capable. 1 = Capable. Set by device dependent code (BIOS or device driver) to indicate that drive 1 for this channel is capable of DMA transfers, and that the controller has been initialized for optimum performance. The ICH6 does not use this bit. It is intended for systems that do not attach BMIDE to the PCI bus.
5	Drive 0 DMA Capable — R/W. 0 = Not Capable 1 = Capable. Set by device dependent code (BIOS or device driver) to indicate that drive 0 for this channel is capable of DMA transfers, and that the controller has been initialized for optimum performance. The ICH6 does not use this bit. It is intended for systems that do not attach BMIDE to the PCI bus.
4:3	Reserved. Returns 0.
2	Interrupt — R/WC. Software can use this bit to determine if an IDE device has asserted its interrupt line (IDEIRQ). 0 = Software clears this bit by writing a 1 to it. If this bit is cleared while the interrupt is still active, this bit will remain clear until another assertion edge is detected on the interrupt line. 1 = Set by the rising edge of the IDE interrupt line, regardless of whether or not the interrupt is masked in the 8259 or the internal I/O APIC. When this bit is read as 1, all data transferred from the drive is visible in system memory.
1	Error — R/WC. 0 = Software clears this bit by writing a 1 to it. 1 = This bit is set when the controller encounters a target abort or master abort when transferring data on PCI.
0	Bus Master IDE Active (ACT) — RO. 0 = This bit is cleared by the ICH6 when the last transfer for a region is performed, where EOT for that region is set in the region descriptor. It is also cleared by the ICH6 when the Start bit is cleared in the Command register. When this bit is read as 0, all data transferred from the drive during the previous bus master command is visible in system memory, unless the bus master command was aborted. 1 = Set by the ICH6 when the Start bit is written to the Command register.

11.2.3 BMIDP—Bus Master IDE Descriptor Table Pointer Register (IDE—D31:F1)

Address Offset: BMIBASE + 04h Attribute: R/W
 Default Value: All bits undefined Size: 32 bits

Bit	Description
31:2	Address of Descriptor Table (ADDR) — R/W. This field corresponds to A[31:2]. The Descriptor Table must be DWord-aligned. The Descriptor Table must not cross a 64-K boundary in memory.
1:0	Reserved

§



12 SATA Controller Registers (D31:F2)

12.1 PCI Configuration Registers (SATA–D31:F2)

Note: Address locations that are not shown should be treated as Reserved.

All of the SATA registers are in the core well. None of the registers can be locked.

Table 12-1. SATA Controller PCI Register Address Map (SATA–D31:F2) (Sheet 1 of 2)

Offset	Mnemonic	Register Name	Default	Type
00–01h	VID	Vendor Identification	8086h	RO
02–03h	DID	Device Identification	2651h ICH6 2652h ICH6R 2653h ICH6-M	RO
04–05h	PCICMD	PCI Command	0000h	R/W, RO
06–07h	PCISTS	PCI Status	02B0h	R/WC, RO
08h	RID	Revision Identification	See register description.	RO
09h	PI	Programming Interface	See register description.	See register description
0Ah	SCC	Sub Class Code	See register description	See register description
0Bh	BCC	Base Class Code	01h	RO
0Dh	PMLT	Primary Master Latency Timer	00h	RO
10–13h	PCMD_BAR	Primary Command Block Base Address	00000001h	R/W, RO
14–17h	PCNL_BAR	Primary Control Block Base Address	00000001h	R/W, RO
18–1Bh	SCMD_BAR	Secondary Command Block Base Address	00000001h	R/W, RO
1C–1Fh	SCNL_BAR	Secondary Control Block Base Address	00000001h	R/W, RO
20–23h	BAR	Legacy Bus Master Base Address	00000001h	R/W, RO
24–27h	ABAR	AHCI Base Address	00000000h	See register description
2C–2Dh	SVID	Subsystem Vendor Identification	0000h	R/WO
2E–2Fh	SID	Subsystem Identification	0000h	R/WO
34h	CAP	Capabilities Pointer	70h	RO
3C	INT_LN	Interrupt Line	00h	R/W
3D	INT_PN	Interrupt Pin	See register description.	RO
40–41h	IDE_TIMP	Primary IDE Timing	0000h	R/W
42–43h	IDE_TIMS	Secondary IDE Timing	0000h	R/W

Table 12-1. SATA Controller PCI Register Address Map (SATA–D31:F2) (Sheet 2 of 2)

Offset	Mnemonic	Register Name	Default	Type
44h	SIDETIM	Slave IDE Timing	00h	R/W
48h	SDMA_CNT	Synchronous DMA Control	00h	R/W
4A–4Bh	SDMA_TIM	Synchronous DMA Timing	0000h	R/W
54–57h	IDE_CONFIG	IDE I/O Configuration	00000000h	R/W
70–71h	PID	PCI Power Management Capability ID	0001h	RO
72–73h	PC	PCI Power Management Capabilities	4002h	RO
74–75h	PMCS	PCI Power Management Control and Status	0000h	R/W, RO, R/WC
90h	MAP	Address Map	00h	R/W
92–93h	PCS	Port Control and Status	0000h	R/W, RO, R/WC
94-97h	SIR	SATA Initialization Register	00000000h	R/W
A0h	SIRI	SATA Indexed Registers Index	00h	R/W
A4h	STRD	SATA Indexed Register Data	XXXXXXXXh	R/W
C0h	ATC	APM Trapping Control	00h	R/W
C4	ATS	ATM Trapping Status	00h	R/WC
D0–D3h	SP	Scratch Pad	00000000h	R/W
E0h– E3h	BFCS	BIST FIS Control/Status	00000000h	R/W, R/WC
E4h– E7h	BFTD1	BIST FIS Transmit Data, DW1	00000000h	R/W
E8h– EBh	BFTD2	BIST FIS Transmit Data, DW2	00000000h	R/W

NOTE: The ICH6 SATA controller is not arbitrated as a PCI device, therefore it does not need a master latency timer.

12.1.1 VID—Vendor Identification Register (SATA—D31:F2)

Offset Address: 00–01h Attribute: RO
 Default Value: 8086h Size: 16 bit
 Lockable: No Power Well: Core

Bit	Description
15:0	Vendor ID — RO. This is a 16-bit value assigned to Intel. Intel VID = 8086h

12.1.2 DID—Device Identification Register (SATA—D31:F2)

Offset Address: 02–03h Attribute: RO
 Default Value: ICH6: 2651h Size: 16 bit
 ICH6R: 2652h
 ICH6-M: 2653h
 Lockable: No Power Well: Core

Bit	Description
15:0	Device ID — RO. This is a 16-bit value assigned to the ICH6 SATA controller.

12.1.3 PCICMD—PCI Command Register (SATA—D31:F2)

Address Offset: 04h–05h Attribute: RO, R/W
 Default Value: 0000h Size: 16 bits

Bit	Description
15:11	Reserved
10	Interrupt Disable — R/W. This bit disables pin-based INTx# interrupts. This bit has no effect on MSI operation. 0 = Internal INTx# messages are generated if there is an interrupt and MSI is not enabled. 1 = Internal INTx# messages will not be generated.
9	Fast Back to Back Enable (FBE) — RO. Reserved as 0.
8	SERR# Enable (SERR_EN) — RO. Reserved as 0.
7	Wait Cycle Control (WCC) — RO. Reserved as 0.
6	Parity Error Response (PER) — R/W. 0 = Disabled. SATA controller will not generate PERR# when a data parity error is detected. 1 = Enabled. SATA controller will generate PERR# when a data parity error is detected.
5	VGA Palette Snoop (VPS) — RO. Reserved as 0.
4	Postable Memory Write Enable (PMWE) — RO. Reserved as 0.
3	Special Cycle Enable (SCE) — RO. Reserved as 0.
2	Bus Master Enable (BME) — R/W. This bit controls the ICH6’s ability to act as a PCI master for IDE Bus Master transfers. This bit does not impact the generation of completions for split transaction commands.
1	Memory Space Enable (MSE) — R/W / RO. This bit controls access to the SATA controller’s target memory space (for AHCI). (ICH6-M/ICH6R only) NOTE: When MAP.MV (offset 90:bits 1:0) is not 00h, this register is Read Only (RO). Software is responsible for clearing this bit before entering combined mode. For ICH6, this bit is RO ‘0’, unless the SCRAE bit (offset 94h:bit 9) is set.
0	I/O Space Enable (IOSE) — R/W. This bit controls access to the I/O space registers. 0 = Disables access to the Legacy or Native IDE ports (both Primary and Secondary) as well as the Bus Master I/O registers. 1 = Enable. Note that the Base Address register for the Bus Master registers should be programmed before this bit is set.

12.1.4 PCISTS — PCI Status Register (SATA–D31:F2)

Address Offset: 06–07h Attribute: R/WC, RO
 Default Value: 02B0h Size: 16 bits

Note: For the writable bits, software must write a 1 to clear bits that are set. Writing a 0 to the bit has no effect.

Bit	Description
15	Detected Parity Error (DPE) — R/WC. 0 = No parity error detected by SATA controller. 1 = SATA controller detects a parity error on its interface.
14	Signaled System Error (SSE) — RO. Reserved as 0.
13	Received Master Abort (RMA) — R/WC. 0 = Master abort Not generated. 1 = SATA controller, as a master, generated a master abort.
12	Reserved as 0 — RO.
11	Signaled Target Abort (STA) — RO. Reserved as 0.
10:9	DEVSEL# Timing Status (DEV_STS) — RO. 01 = Hardwired; Controls the device select time for the SATA controller's PCI interface.
8	Data Parity Error Detected (DPED) — RO. For ICH6, this bit can only be set on read completions received from SiBUS where there is a parity error. 1 = SATA controller, as a master, either detects a parity error or sees the parity error line asserted, and the parity error response bit (bit 6 of the command register) is set.
7	Fast Back to Back Capable (FB2BC) — RO. Reserved as 1.
6	User Definable Features (UDF) — RO. Reserved as 0.
5	66MHz Capable (66MHZ_CAP) — RO. Reserved as 1.
4	Capabilities List (CAP_LIST) — RO. This bit indicates the presence of a capabilities list. The minimum requirement for the capabilities list must be PCI power management for the SATA controller.
3	Interrupt Status (INTS) — RO. Reflects the state of INTx# messages. 0 = Interrupt is cleared (independent of the state of Interrupt Disable bit in the command register [offset 04h]). 1 = Interrupt is to be asserted
2:0	Reserved

12.1.5 RID—Revision Identification Register (SATA–D31:F2)

Offset Address: 08h Attribute: RO
 Default Value: See bit description Size: 8 bits

Bit	Description
7:0	Revision ID — RO. Refer to the <i>Intel® I/O Controller Hub 6 (ICH6) Family Specification Update</i> for the value of the Revision ID Register

12.1.6 PI—Programming Interface Register (SATA–D31:F2)

12.1.6.1 When Sub Class Code Register (D31:F2:Offset 0Ah) = 01h

Address Offset: 09h Attribute: R/W, RO
 Default Value: See bit description Size: 8 bits

Bit	Description
7	This read-only bit is a 1 to indicate that the ICH6 supports bus master operation
6:4	Reserved. Will always return 0.
3	Secondary Mode Native Capable (SNC) — RO. 0 = Secondary controller only supports legacy mode. 1 = Secondary controller supports both legacy and native modes. When MAP.MV (D31:F2:Offset 90:bits 1:0) is any value other than 00b, this bit reports as a 0. When MAP.MV is 00b, this bit reports as a 1.
2	Secondary Mode Native Enable (SNE) — R/W / RO. This bit determines the mode that the secondary channel is operating in. 0 = Secondary controller operating in legacy (compatibility) mode 1 = Secondary controller operating in native PCI mode. When MAP.MV (D31:F2:Offset 90:bits 1:0) is any value other than 00b, this bit is read-only (RO). Software is responsible for clearing this bit before entering combined mode. When MAP.MV is 00b, this bit is read/write (R/W). If this bit is set by software, then the PNE bit (bit 0 of this register) must also be set by software. While in theory these bits can be programmed separately, such a configuration is not supported by hardware.
1	Primary Mode Native Capable (PNC) — RO. 0 = Primary controller only supports legacy mode. 1 = Primary controller supports both legacy and native modes. When MAP.MV (D31:F2:Offset 90:bits 1:0) is any value other than 00b, this bit reports as a 0. When MAP.MV is 00b, this bit reports as a 1
0	Primary Mode Native Enable (PNE) — R/W / RO. This bit determines the mode that the primary channel is operating in. 0 = Primary controller operating in legacy (compatibility) mode. 1 = Primary controller operating in native PCI mode. When MAP.MV (D31:F2:Offset 90:bits 1:0) is any value other than 00b, this bit is read-only (RO). Software is responsible for clearing this bit before entering combined mode. When MAP.MV is 00b, this bit is read/write (R/W). If this bit is set by software, then the SNE bit (bit 2 of this register) must also be set by software. While in theory these bits can be programmed separately, such a configuration is not supported by hardware.

12.1.6.2 When Sub Class Code Register (D31:F2:Offset 0Ah) = 04h

Address Offset: 09h Attribute: RO
 Default Value: 00h Size: 8 bits

Bit	Description
7:0	Interface (IF) — RO. When configured as RAID, this register becomes read only 0.

12.1.6.3 When Sub Class Code Register (D31:F2:Offset 0Ah) = 06h

Address Offset: 09h
 Default Value: 01h

Attribute: RO
 Size: 8 bits

Bit	Description
7:0	Interface (IF) — RO. This field indicates the SATA Controller supports AHCI, rev 1.0.

12.1.7 SCC—Sub Class Code Register (SATA–D31:F2)

Address Offset: 0Ah
 Default Value: See bit description

Attribute: See bit description
 Size: 8 bits

Bit	Description																			
7:0	<p>Sub Class Code (SCC). This field specifies the sub-class code of the controller, per the table below:</p> <p>Intel® ICH6 Only:</p> <table border="1"> <thead> <tr> <th>SCC Register Attribute</th> <th>SCC Register Value</th> </tr> </thead> <tbody> <tr> <td>RO</td> <td>01h (IDE Controller)</td> </tr> </tbody> </table> <p>ICH6-M Only:</p> <table border="1"> <thead> <tr> <th>MAP.USCC (D31:F2:Offset 90h:bit 7)</th> <th>SCC Register Attribute</th> <th>SCC Register Value</th> </tr> </thead> <tbody> <tr> <td>0b</td> <td>RO</td> <td>01h (IDE Controller)</td> </tr> <tr> <td>1b</td> <td>RO</td> <td>06h (SATA Controller)</td> </tr> </tbody> </table> <p>ICH6R Only:</p> <table border="1"> <thead> <tr> <th>MAP.USCC (D31:F2:Offset 90h:bit 7)</th> <th>SCC Register Attribute</th> <th>SCC Default Register Value</th> </tr> </thead> <tbody> <tr> <td>X</td> <td>R/WO</td> <td>04h (RAID Controller)</td> </tr> </tbody> </table>	SCC Register Attribute	SCC Register Value	RO	01h (IDE Controller)	MAP.USCC (D31:F2:Offset 90h:bit 7)	SCC Register Attribute	SCC Register Value	0b	RO	01h (IDE Controller)	1b	RO	06h (SATA Controller)	MAP.USCC (D31:F2:Offset 90h:bit 7)	SCC Register Attribute	SCC Default Register Value	X	R/WO	04h (RAID Controller)
SCC Register Attribute	SCC Register Value																			
RO	01h (IDE Controller)																			
MAP.USCC (D31:F2:Offset 90h:bit 7)	SCC Register Attribute	SCC Register Value																		
0b	RO	01h (IDE Controller)																		
1b	RO	06h (SATA Controller)																		
MAP.USCC (D31:F2:Offset 90h:bit 7)	SCC Register Attribute	SCC Default Register Value																		
X	R/WO	04h (RAID Controller)																		

12.1.8 BCC—Base Class Code Register (SATA–D31:F2)

Address Offset: 0Bh
 Default Value: 01h

Attribute: RO
 Size: 8 bits

Bit	Description
7:0	Base Class Code (BCC) — RO. 01h = Mass storage device

12.1.9 PMLT—Primary Master Latency Timer Register (SATA–D31:F2)

Address Offset: 0Dh Attribute: RO
 Default Value: 00h Size: 8 bits

Bit	Description
7:0	Master Latency Timer Count (MLTC) — RO. The SATA controller is implemented internally, and is not arbitrated as a PCI device, so it does not need a Master Latency Timer. 00h = Hardwired.

12.1.10 PCMD_BAR—Primary Command Block Base Address Register (SATA–D31:F2)

Address Offset: 10h–13h Attribute: R/W, RO
 Default Value: 00000001h Size: 32 bits

Bit	Description
31:16	Reserved
15:3	Base Address — R/W. This field provides the base address of the I/O space (8 consecutive I/O locations).
2:1	Reserved
0	Resource Type Indicator (RTE) — RO. Hardwired to 1 to indicate a request for I/O space.

NOTE: This 8-byte I/O space is used in native mode for the Primary Controller’s Command Block.

12.1.11 PCNL_BAR—Primary Control Block Base Address Register (SATA–D31:F2)

Address Offset: 14h–17h Attribute: R/W, RO
 Default Value: 00000001h Size: 32 bits

Bit	Description
31:16	Reserved
15:2	Base Address — R/W. This field provides the base address of the I/O space (4 consecutive I/O locations).
1	Reserved
0	Resource Type Indicator (RTE) — RO. Hardwired to 1 to indicate a request for I/O space.

NOTE: This 4-byte I/O space is used in native mode for the Primary Controller’s Command Block.

12.1.12 SCMD_BAR—Secondary Command Block Base Address Register (IDE D31:F1)

Address Offset: 18h–1Bh Attribute: R/W, RO
 Default Value: 00000001h Size: 32 bits

Bit	Description
31:16	Reserved
15:3	Base Address — R/W. This field provides the base address of the I/O space (8 consecutive I/O locations).
2:1	Reserved
0	Resource Type Indicator (RTE) — RO. Hardwired to 1 to indicate a request for I/O space.

NOTE: This 4-byte I/O space is used in native mode for the Secondary Controller's Command Block.

12.1.13 SCNL_BAR—Secondary Control Block Base Address Register (IDE D31:F1)

Address Offset: 1Ch–1Fh Attribute: R/W, RO
 Default Value: 00000001h Size: 32 bits

Bit	Description
31:16	Reserved
15:2	Base Address — R/W. This field provides the base address of the I/O space (4 consecutive I/O locations).
1	Reserved
0	Resource Type Indicator (RTE) — RO. Hardwired to 1 to indicate a request for I/O space.

NOTE: This 4-byte I/O space is used in native mode for the Secondary Controller's Command Block.

12.1.14 BAR — Legacy Bus Master Base Address Register (SATA–D31:F2)

Address Offset: 20h–23h Attribute: R/W, RO
 Default Value: 00000001h Size: 32 bits

The Bus Master IDE interface function uses Base Address register 5 to request a 16-byte I/O space to provide a software interface to the Bus Master functions. Only 12 bytes are actually used (6 bytes for primary, 6 bytes for secondary). Only bits [15:4] are used to decode the address.

Bit	Description
31:16	Reserved
15:4	Base Address — R/W. This field provides the base address of the I/O space (16 consecutive I/O locations).
3:1	Reserved
0	Resource Type Indicator (RTE) — RO. Hardwired to 1 to indicate a request for I/O space.

12.1.15 ABAR — AHCI Base Address Register (SATA–D31:F2)

12.1.15.1 Intel® ICH6 Only

Address Offset: 24h–27h Attribute: RO
 Default Value: 00000000h Size: 32 bits

Bit	Description
31:0	Reserved

Note: For ICH6, this register is Reserved and Read Only, unless the SCRAE bit (offset 94h:bit 9) is set, in which case the register follows the definition given in Section 12.1.15.2.

12.1.15.2 Intel® ICH6R / ICH6-M Only

Address Offset: 24h–27h Attribute: R/W, RO
 Default Value: 00000000h Size: 32 bits

This register allocates space for the memory registers defined in Section 12.3.

Bit	Description
31:10	Base Address (BA) — R/W. Base address of register memory space (aligned to 1 KB)
9:4	Reserved
3	Prefetchable (PF) — RO. This bit indicates that this range is not pre-fetchable
2:1	Type (TP) — RO. This bit indicates that this range can be mapped anywhere in 32-bit address space.
0	Resource Type Indicator (RTE) — RO. Hardwired to 0 to indicate a request for register memory space.

NOTES:

1. When the MAP.MV register is programmed for combined mode (00b), this register is RO. Software is responsible for clearing this bit before entering combined mode.
2. The ABAR register must be set to a value of 0001_0000h or greater.

12.1.16 SVID—Subsystem Vendor Identification Register (SATA–D31:F2)

Address Offset: 2Ch–2Dh Attribute: R/WO
 Default Value: 0000h Size: 16 bits
 Lockable: No Power Well: Core

Bit	Description
15:0	Subsystem Vendor ID (SVID) — R/WO. Value is written by BIOS. No hardware action taken on this value.

12.1.17 SID—Subsystem Identification Register (SATA–D31:F2)

Address Offset: 2Eh–2Fh Attribute: R/WO
 Default Value: 0000h Size: 16 bits
 Lockable: No Power Well: Core

Bit	Description
15:0	Subsystem ID (SID) — R/WO. Value is written by BIOS. No hardware action taken on this value.

12.1.18 CAP—Capabilities Pointer Register (SATA–D31:F2)

Address Offset: 34h Attribute: RO
 Default Value: 70h Size: 8 bits

Bit	Description
7:0	Capabilities Pointer (CAP_PTR) — RO. This field indicates that the first capability pointer offset is 70h, the PCI Power Management capability.

12.1.19 INT_LN—Interrupt Line Register (SATA–D31:F2)

Address Offset: 3Ch Attribute: R/W
 Default Value: 00h Size: 8 bits

Bit	Description
7:0	Interrupt Line — R/W. This field is used to communicate to software the interrupt line that the interrupt pin is connected to.

12.1.20 INT_PN—Interrupt Pin Register (SATA–D31:F2)

Address Offset: 3Dh Attribute: RO
 Default Value: See Register Description Size: 8 bits

Bit	Description
7:0	Interrupt Pin — RO. This reflects the value of D31IP.SIP (Chipset Configuration Registers:Offset 3100h:bits 11:8).

12.1.21 IDE_TIM — IDE Timing Register (SATA–D31:F2)

Address Offset: Primary: 40–41h Attribute: R/W
 Secondary: 42–43h
 Default Value: 0000h Size: 16 bits

This register controls the timings driven on the IDE cable for PIO and 8237 style DMA transfers. It also controls operation of the buffer for PIO transfers.

Note: This register is R/W to maintain software compatibility and enable parallel ATA functionality when the PCI functions are combined. These bits have no effect on SATA operation unless otherwise noted.

Bit	Description
15	<p>IDE Decode Enable (IDE) — R/W. Individually enable/disable the Primary or Secondary decode.</p> <p>0 = Disable. 1 = Enables the Intel® ICH6 to decode the associated Command Blocks (1F0–1F7h for primary, 170–177h for secondary) and Control Block (3F6h for primary and 376h for secondary). This bit effects the IDE decode ranges for both legacy and native-Mode decoding.</p> <p>NOTE: This bit affects SATA operation in both combined and non-combined ATA modes. See Section 5.17 for more on ATA modes of operation.</p>
14	<p>Drive 1 Timing Register Enable (SITRE) — R/W.</p> <p>0 = Use bits 13:12, 9:8 for both drive 0 and drive 1. 1 = Use bits 13:12, 9:8 for drive 0, and use the Slave IDE Timing register for drive 1</p>
13:12	<p>IORDY Sample Point (ISP) — R/W. The setting of these bits determines the number of PCI clocks between IDE IOR#/IOW# assertion and the first IORDY sample point.</p> <p>00 = 5 clocks 01 = 4 clocks 10 = 3 clocks 11 = Reserved</p>
11:10	Reserved
9:8	<p>Recovery Time (RCT) — R/W. The setting of these bits determines the minimum number of PCI clocks between the last IORDY sample point and the IOR#/IOW# strobe of the next cycle.</p> <p>00 = 4 clocks 01 = 3 clocks 10 = 2 clocks 11 = 1 clock</p>
7	<p>Drive 1 DMA Timing Enable (DTE1) — R/W.</p> <p>0 = Disable. 1 = Enable the fast timing mode for DMA transfers only for this drive. PIO transfers to the IDE data port will run in compatible timing.</p>
6	<p>Drive 1 Prefetch/Posting Enable (PPE1) — R/W.</p> <p>0 = Disable. 1 = Enable Prefetch and posting to the IDE data port for this drive.</p>
5	<p>Drive 1 IORDY Sample Point Enable (IE1) — R/W.</p> <p>0 = Disable IORDY sampling for this drive. 1 = Enable IORDY sampling for this drive.</p>

Bit	Description
4	Drive 1 Fast Timing Bank (TIME1) — R/W. 0 = Accesses to the data port will use compatible timings for this drive. 1 = When this bit =1 and bit 14 = 0, accesses to the data port will use bits 13:12 for the IORDY sample point, and bits 9:8 for the recovery time. When this bit = 1 and bit 14 = 1, accesses to the data port will use the IORDY sample point and recover time specified in the slave IDE timing register.
3	Drive 0 DMA Timing Enable (DTE0) — R/W. 0 = Disable 1 = Enable fast timing mode for DMA transfers only for this drive. PIO transfers to the IDE data port will run in compatible timing.
2	Drive 0 Prefetch/Posting Enable (PPE0) — R/W. 0 = Disable prefetch and posting to the IDE data port for this drive. 1 = Enable prefetch and posting to the IDE data port for this drive.
1	Drive 0 IORDY Sample Point Enable (IE0) — R/W. 0 = Disable IORDY sampling is disabled for this drive. 1 = Enable IORDY sampling for this drive.
0	Drive 0 Fast Timing Bank (TIME0) — R/W. 0 = Accesses to the data port will use compatible timings for this drive. 1 = Accesses to the data port will use bits 13:12 for the IORDY sample point, and bits 9:8 for the recovery time

12.1.23 SDMA_CNT—Synchronous DMA Control Register (SATA–D31:F2)

Address Offset: 48h
Default Value: 00h

Attribute: R/W
Size: 8 bits

Note: This register is R/W to maintain software compatibility and enable parallel ATA functionality when the PCI functions are combined. These bits have no effect on SATA operation unless otherwise noted.

Bit	Description
7:4	Reserved
3	Secondary Drive 1 Synchronous DMA Mode Enable (SSDE1) — R/W. 0 = Disable (default) 1 = Enable Synchronous DMA mode for secondary channel drive 1
2	Secondary Drive 0 Synchronous DMA Mode Enable (SSDE0) — R/W. 0 = Disable (default) 1 = Enable Synchronous DMA mode for secondary drive 0.
1	Primary Drive 1 Synchronous DMA Mode Enable (PSDE1) — R/W. 0 = Disable (default) 1 = Enable Synchronous DMA mode for primary channel drive 1
0	Primary Drive 0 Synchronous DMA Mode Enable (PSDE0) — R/W. 0 = Disable (default) 1 = Enable Synchronous DMA mode for primary channel drive 0

12.1.24 SDMA_TIM—Synchronous DMA Timing Register (SATA–D31:F2)

Address Offset: 4A–4Bh
 Default Value: 0000h

Attribute: R/W
 Size: 16 bits

Note: This register is R/W to maintain software compatibility and enable parallel ATA functionality when the PCI functions are combined. These bits have no effect on SATA operation, unless otherwise noted.

Bit	Description															
15:14	Reserved															
13:12	<p>Secondary Drive 1 Cycle Time (SCT1) — R/W. For Ultra ATA mode. The setting of these bits determines the minimum write strobe cycle time (CT). The DMARDY#-to-STOP (RP) time is also determined by the setting of these bits.</p> <table border="0"> <tr> <td>SCB1 = 0 (33 MHz clk)</td> <td>SCB1 = 1 (66 MHz clk)</td> <td>FAST_SCB1 = 1 (133 MHz clk)</td> </tr> <tr> <td>00 = CT 4 clocks, RP 6 clocks</td> <td>00 = Reserved</td> <td>00 = Reserved</td> </tr> <tr> <td>01 = CT 3 clocks, RP 5 clocks</td> <td>01 = CT 3 clocks, RP 8 clocks</td> <td>01 = CT 3 clocks, RP 16 clocks</td> </tr> <tr> <td>10 = CT 2 clocks, RP 4 clocks</td> <td>10 = CT 2 clocks, RP 8 clocks</td> <td>10 = Reserved</td> </tr> <tr> <td>11 = Reserved</td> <td>11 = Reserved</td> <td>11 = Reserved</td> </tr> </table>	SCB1 = 0 (33 MHz clk)	SCB1 = 1 (66 MHz clk)	FAST_SCB1 = 1 (133 MHz clk)	00 = CT 4 clocks, RP 6 clocks	00 = Reserved	00 = Reserved	01 = CT 3 clocks, RP 5 clocks	01 = CT 3 clocks, RP 8 clocks	01 = CT 3 clocks, RP 16 clocks	10 = CT 2 clocks, RP 4 clocks	10 = CT 2 clocks, RP 8 clocks	10 = Reserved	11 = Reserved	11 = Reserved	11 = Reserved
SCB1 = 0 (33 MHz clk)	SCB1 = 1 (66 MHz clk)	FAST_SCB1 = 1 (133 MHz clk)														
00 = CT 4 clocks, RP 6 clocks	00 = Reserved	00 = Reserved														
01 = CT 3 clocks, RP 5 clocks	01 = CT 3 clocks, RP 8 clocks	01 = CT 3 clocks, RP 16 clocks														
10 = CT 2 clocks, RP 4 clocks	10 = CT 2 clocks, RP 8 clocks	10 = Reserved														
11 = Reserved	11 = Reserved	11 = Reserved														
11:10	Reserved															
9:8	<p>Secondary Drive 0 Cycle Time (SCT0) — R/W. For Ultra ATA mode. The setting of these bits determines the minimum write strobe cycle time (CT). The DMARDY#-to-STOP (RP) time is also determined by the setting of these bits.</p> <table border="0"> <tr> <td>SCB1 = 0 (33 MHz clk)</td> <td>SCB1 = 1 (66 MHz clk)</td> <td>FAST_SCB1 = 1 (133 MHz clk)</td> </tr> <tr> <td>00 = CT 4 clocks, RP 6 clocks</td> <td>00 = Reserved</td> <td>00 = Reserved</td> </tr> <tr> <td>01 = CT 3 clocks, RP 5 clocks</td> <td>01 = CT 3 clocks, RP 8 clocks</td> <td>01 = CT 3 clocks, RP 16 clocks</td> </tr> <tr> <td>10 = CT 2 clocks, RP 4 clocks</td> <td>10 = CT 2 clocks, RP 8 clocks</td> <td>10 = Reserved</td> </tr> <tr> <td>11 = Reserved</td> <td>11 = Reserved</td> <td>11 = Reserved</td> </tr> </table>	SCB1 = 0 (33 MHz clk)	SCB1 = 1 (66 MHz clk)	FAST_SCB1 = 1 (133 MHz clk)	00 = CT 4 clocks, RP 6 clocks	00 = Reserved	00 = Reserved	01 = CT 3 clocks, RP 5 clocks	01 = CT 3 clocks, RP 8 clocks	01 = CT 3 clocks, RP 16 clocks	10 = CT 2 clocks, RP 4 clocks	10 = CT 2 clocks, RP 8 clocks	10 = Reserved	11 = Reserved	11 = Reserved	11 = Reserved
SCB1 = 0 (33 MHz clk)	SCB1 = 1 (66 MHz clk)	FAST_SCB1 = 1 (133 MHz clk)														
00 = CT 4 clocks, RP 6 clocks	00 = Reserved	00 = Reserved														
01 = CT 3 clocks, RP 5 clocks	01 = CT 3 clocks, RP 8 clocks	01 = CT 3 clocks, RP 16 clocks														
10 = CT 2 clocks, RP 4 clocks	10 = CT 2 clocks, RP 8 clocks	10 = Reserved														
11 = Reserved	11 = Reserved	11 = Reserved														
7:6	Reserved															
5:4	<p>Primary Drive 1 Cycle Time (PCT1) — R/W. For Ultra ATA mode, the setting of these bits determines the minimum write strobe cycle time (CT). The DMARDY#-to-STOP (RP) time is also determined by the setting of these bits.</p> <table border="0"> <tr> <td>PCB1 = 0 (33 MHz clk)</td> <td>PCB1 = 1 (66 MHz clk)</td> <td>FAST_PCB1 = 1 (133 MHz clk)</td> </tr> <tr> <td>00 = CT 4 clocks, RP 6 clocks</td> <td>00 = Reserved</td> <td>00 = Reserved</td> </tr> <tr> <td>01 = CT 3 clocks, RP 5 clocks</td> <td>01 = CT 3 clocks, RP 8 clocks</td> <td>01 = CT 3 clocks, RP 16 clocks</td> </tr> <tr> <td>10 = CT 2 clocks, RP 4 clocks</td> <td>10 = CT 2 clocks, RP 8 clocks</td> <td>10 = Reserved</td> </tr> <tr> <td>11 = Reserved</td> <td>11 = Reserved</td> <td>11 = Reserved</td> </tr> </table>	PCB1 = 0 (33 MHz clk)	PCB1 = 1 (66 MHz clk)	FAST_PCB1 = 1 (133 MHz clk)	00 = CT 4 clocks, RP 6 clocks	00 = Reserved	00 = Reserved	01 = CT 3 clocks, RP 5 clocks	01 = CT 3 clocks, RP 8 clocks	01 = CT 3 clocks, RP 16 clocks	10 = CT 2 clocks, RP 4 clocks	10 = CT 2 clocks, RP 8 clocks	10 = Reserved	11 = Reserved	11 = Reserved	11 = Reserved
PCB1 = 0 (33 MHz clk)	PCB1 = 1 (66 MHz clk)	FAST_PCB1 = 1 (133 MHz clk)														
00 = CT 4 clocks, RP 6 clocks	00 = Reserved	00 = Reserved														
01 = CT 3 clocks, RP 5 clocks	01 = CT 3 clocks, RP 8 clocks	01 = CT 3 clocks, RP 16 clocks														
10 = CT 2 clocks, RP 4 clocks	10 = CT 2 clocks, RP 8 clocks	10 = Reserved														
11 = Reserved	11 = Reserved	11 = Reserved														
3:2	Reserved															
1:0	<p>Primary Drive 0 Cycle Time (PCT0) — R/W. For Ultra ATA mode, the setting of these bits determines the minimum write strobe cycle time (CT). The DMARDY#-to-STOP (RP) time is also determined by the setting of these bits.</p> <table border="0"> <tr> <td>PCB1 = 0 (33 MHz clk)</td> <td>PCB1 = 1 (66 MHz clk)</td> <td>FAST_PCB1 = 1 (133 MHz clk)</td> </tr> <tr> <td>00 = CT 4 clocks, RP 6 clocks</td> <td>00 = Reserved</td> <td>00 = Reserved</td> </tr> <tr> <td>01 = CT 3 clocks, RP 5 clocks</td> <td>01 = CT 3 clocks, RP 8 clocks</td> <td>01 = CT 3 clocks, RP 16 clocks</td> </tr> <tr> <td>10 = CT 2 clocks, RP 4 clocks</td> <td>10 = CT 2 clocks, RP 8 clocks</td> <td>10 = Reserved</td> </tr> <tr> <td>11 = Reserved</td> <td>11 = Reserved</td> <td>11 = Reserved</td> </tr> </table>	PCB1 = 0 (33 MHz clk)	PCB1 = 1 (66 MHz clk)	FAST_PCB1 = 1 (133 MHz clk)	00 = CT 4 clocks, RP 6 clocks	00 = Reserved	00 = Reserved	01 = CT 3 clocks, RP 5 clocks	01 = CT 3 clocks, RP 8 clocks	01 = CT 3 clocks, RP 16 clocks	10 = CT 2 clocks, RP 4 clocks	10 = CT 2 clocks, RP 8 clocks	10 = Reserved	11 = Reserved	11 = Reserved	11 = Reserved
PCB1 = 0 (33 MHz clk)	PCB1 = 1 (66 MHz clk)	FAST_PCB1 = 1 (133 MHz clk)														
00 = CT 4 clocks, RP 6 clocks	00 = Reserved	00 = Reserved														
01 = CT 3 clocks, RP 5 clocks	01 = CT 3 clocks, RP 8 clocks	01 = CT 3 clocks, RP 16 clocks														
10 = CT 2 clocks, RP 4 clocks	10 = CT 2 clocks, RP 8 clocks	10 = Reserved														
11 = Reserved	11 = Reserved	11 = Reserved														

12.1.25 IDE_CONFIG—IDE I/O Configuration Register (SATA–D31:F2)

Address Offset: 54h–57h Attribute: R/W
 Default Value: 00000000h Size: 32 bits

Note: This register is R/W to maintain software compatibility and enable parallel ATA functionality when the PCI functions are combined. These bits have no effect on SATA operation, unless otherwise noted.

Bit	Description
31:24	Reserved
23:20	Scratchpad (SP2). Intel® ICH6 does not perform any actions on these bits.
19:18	<p>SEC_SIG_MODE — R/W. These bits are used to control mode of the Secondary IDE signal pins for swap bay support.</p> <p>If the SRS bit (Chipset Configuration Registers:Offset 3414h:bit 1) is 1, the reset states of bits 19:18 will be 01 (tri-state) instead of 00 (normal).</p> <p>00 = Normal (Enabled) 01 = Tri-state (Disabled) 10 = Drive low (Disabled) 11 = Reserved</p>
17:16	<p>PRIM_SIG_MODE — R/W. These bits are used to control mode of the Primary IDE signal pins for mobile swap bay support.</p> <p>If the PRS bit (Chipset Configuration Registers:Offset 3414h:bit 1) is 1, the reset states of bits 17:16 will be 01 (tri-state) instead of 00 (normal).</p> <p>00 = Normal (Enabled) 01 = Tri-state (Disabled) 10 = Drive low (Disabled) 11 = Reserved</p>
15	<p>Fast Secondary Drive 1 Base Clock (FAST_SCB1) — R/W. This bit is used in conjunction with the SCT1 bits (D31:F2:4Ah, bits 13:12) to enable/disable Ultra ATA/100 timings for the Secondary Slave drive.</p> <p>0 = Disable Ultra ATA/100 timing for the Secondary Slave drive. 1 = Enable Ultra ATA/100 timing for the Secondary Slave drive (overrides bit 3 in this register).</p>
14	<p>Fast Secondary Drive 0 Base Clock (FAST_SCB0) — R/W. This bit is used in conjunction with the SCT0 bits (D31:F2:4Ah, bits 9:8) to enable/disable Ultra ATA/100 timings for the Secondary Master drive.</p> <p>0 = Disable Ultra ATA/100 timing for the Secondary Master drive. 1 = Enable Ultra ATA/100 timing for the Secondary Master drive (overrides bit 2 in this register).</p>
13	<p>Fast Primary Drive 1 Base Clock (FAST_PCB1) — R/W. This bit is used in conjunction with the PCT1 bits (D31:F2:4Ah, bits 5:4) to enable/disable Ultra ATA/100 timings for the Primary Slave drive.</p> <p>0 = Disable Ultra ATA/100 timing for the Primary Slave drive. 1 = Enable Ultra ATA/100 timing for the Primary Slave drive (overrides bit 1 in this register).</p>
12	<p>Fast Primary Drive 0 Base Clock (FAST_PCB0) — R/W. This bit is used in conjunction with the PCT0 bits (D31:F2:4Ah, bits 1:0) to enable/disable Ultra ATA/100 timings for the Primary Master drive.</p> <p>0 = Disable Ultra ATA/100 timing for the Primary Master drive. 1 = Enable Ultra ATA/100 timing for the Primary Master drive (overrides bit 0 in this register).</p>
11:8	Reserved
7:4	Scratchpad (SP1). ICH6 does not perform any action on these bits.

Bit	Description
3	Secondary Drive 1 Base Clock (SCB1) — R/W. 0 = 33 MHz base clock for Ultra ATA timings. 1 = 66 MHz base clock for Ultra ATA timings
2	Secondary Drive 0 Base Clock (SCB0) — R/W. 0 = 33 MHz base clock for Ultra ATA timings. 1 = 66 MHz base clock for Ultra ATA timings
1	Primary Drive 1 Base Clock (PCB1) — R/W. 0 = 33 MHz base clock for Ultra ATA timings. 1 = 66 MHz base clock for Ultra ATA timings
0	Primary Drive 0 Base Clock (PCB0) — R/W. 0 = 33 MHz base clock for Ultra ATA timings. 1 = 66 MHz base clock for Ultra ATA timings

12.1.26 PID—PCI Power Management Capability Identification Register (SATA-D31:F2)

Address Offset: 70–71h Attribute: RO
Default Value: 0001h Size: 16 bits

Bits	Description
15:8	Next Capability (NEXT) — RO. Indicates that this is the last item in the list.
7:0	Capability ID (CID) — RO. Indicates that this pointer is a PCI power management.

12.1.27 PC—PCI Power Management Capabilities Register (SATA-D31:F2)

Address Offset: 72–73h Attribute: RO
Default Value: 4002h Size: 16 bits

Bits	Description
15:11	PME Support (PME_SUP) — RO. This field indicates PME# can be generated from the D3 _{HOT} state in the SATA host controller.
10	D2 Support (D2_SUP) — RO. Hardwired to 0. The D2 state is not supported
9	D1 Support (D1_SUP) — RO. Hardwired to 0. The D1 state is not supported
8:6	Auxiliary Current (AUX_CUR) — RO. PME# from D3 _{COLD} state is not supported, therefore this field is 000b.
5	Device Specific Initialization (DSI) — RO. Hardwired to 0 to indicate that no device-specific initialization is required.
4	Reserved
3	PME Clock (PME_CLK) — RO. Hardwired to 0 to indicate that PCI clock is not required to generate PME#.
2:0	Version (VER) — RO. Hardwired to 010 to indicates support for Revision 1.1 of the PCI Power Management Specification.

12.1.28 PMCS—PCI Power Management Control and Status Register (SATA–D31:F2)

Address Offset: 74–75h Attribute: RO, R/W, R/WC
 Default Value: 0000h Size: 16 bits

Bits	Description
15	PME Status (PMES) — R/WC. Bit is set when a PME event is to be requested, and if this bit and PMEE is set, a PME# will be generated from the SATA controller
14:9	Reserved
8	PME Enable (PMEE) — R/W. When set, the SATA controller generates PME# form D3 _{HOT} on a wake event.
7:2	Reserved
1:0	Power State (PS) — R/W. These bits are used both to determine the current power state of the SATA controller and to set a new power state. 00 = D0 state 11 = D3 _{HOT} state When in the D3 _{HOT} state, the controller's configuration space is available, but the I/O and memory spaces are not. Additionally, interrupts are blocked.

12.1.29 MAP—Address Map Register (SATA–D31:F2)

Address Offset: 90h Attribute: R/W
 Default Value: 00h Size: 8 bits

Bits	Description
7	Use SATA Class Code (USCC) — R/W. ICH6 / ICH6R Only: Reserved. Software must not set this bit. ICH6-M Only: 0 =Subclass code reported in SCC (D31:F2:Offset 0Ah) is 01h (IDE Controller). 1 =Subclass code reported in SCC is 06h (SATA controller).
6:2	Reserved.
1:0	Map Value — R/W. Map Value (MV): The value in the bits below indicate the address range the SATA ports responds to, and whether or not the PATA and SATA functions are combined. When in combined mode, the AHCI memory space is not available and AHCI may not be used. 00 = Non-combined. P0 is primary master, P2 is the primary slave. P1 is secondary master, P3 is the secondary slave (desktop only). P0 is primary master, P2 is the primary slave (mobile only). 01 = Combined. IDE is primary. P1 is secondary master, P3 is the secondary slave. (desktop only) 10 = Combined. P0 is primary master. P2 is primary slave. IDE is secondary 11 = Reserved

12.1.30 PCS—Port Control and Status Register (SATA–D31:F2)

Address Offset:	92h–93h	Attribute:	R/W, R/WC, RO
Default Value:	0000h	Size:	16 bits

This register is only used in systems that do not support AHCI. In AHCI enabled systems, bits[3:0] must always be set (ICH6R only) / bits[2,0] must always be set (ICH6-M only), and the status of the port is controlled through AHCI memory space.

Bits	Description
15:8	Reserved.
7 (Desktop Only)	Port 3 Present (P3P) — RO. The status of this bit may change at any time. This bit is cleared when the port is disabled via P3E. This bit is not cleared upon surprise removal of a device. 0 = No device detected. 1 = The presence of a device on Port 3 has been detected.
7 (Mobile Only)	Reserved
6	Port 2 Present (P2P) — RO. The status of this bit may change at any time. This bit is cleared when the port is disabled via P2E. This bit is not cleared upon surprise removal of a device. 0 = No device detected. 1 = The presence of a device on Port 2 has been detected.
5 (Desktop Only)	Port 1 Present (P1P) — RO. The status of this bit may change at any time. This bit is cleared when the port is disabled via P1E. This bit is not cleared upon surprise removal of a device. 0 = No device detected. 1 = The presence of a device on Port 1 has been detected.
5 (Mobile Only)	Reserved
4	Port 0 Present (P0P) — RO. The status of this bit may change at any time. This bit is cleared when the port is disabled via P0E. This bit is not cleared upon surprise removal of a device. 0 = No device detected. 1 = The presence of a device on Port 0 has been detected.
3 (Desktop Only)	Port 3 Enabled (P3E) — R/W. 0 = Disabled. The port is in the 'off' state and cannot detect any devices. 1 = Enabled. The port can transition between the on, partial, and slumber states and can detect devices. NOTE: This bit takes precedence over P3CMD.SUD (offset ABAR+298h:bit 1)
3 (Mobile Only)	Reserved
2	Port 2 Enabled (P2E) — R/W. 0 = Disabled. The port is in the 'off' state and cannot detect any devices. 1 = Enabled. The port can transition between the on, partial, and slumber states and can detect devices. NOTE: This bit takes precedence over P2CMD.SUD (offset ABAR+218h:bit 1)
1 (Desktop Only)	Port 1 Enabled (P1E) — R/W. 0 = Disabled. The port is in the 'off' state and cannot detect any devices. 1 = Enabled. The port can transition between the on, partial, and slumber states and can detect devices. NOTE: This bit takes precedence over P1CMD.SUD (offset ABAR+198h:bit 1)

Bits	Description
1 (Mobile Only)	Reserved
0	<p>Port 0 Enabled (P0E) — R/W.</p> <p>0 = Disabled. The port is in the 'off' state and cannot detect any devices. 1 = Enabled. The port can transition between the on, partial, and slumber states and can detect devices.</p> <p>NOTE: This bit takes precedence over P0CMD.SUD (offset ABAR+118h:bit 1)</p>

12.1.31 SIR - SATA Initialization Register

Address Offset: 94h Attribute: R/W
 Default Value: 00000000h Size: 32 bits

Bit	Description
31:28	Reserved
27:24 (Desktop Only)	Reserved
27:24 (Mobile Only)	<p>SATA Initialization Field 3 (SIF3) — R/W. BIOS shall always program this field to the value 0Ah. All other values are reserved.</p>
23	<p>SATA Initialization Field 2 (SIF2) — R/W. BIOS shall always program this register to the value 1b. All other values are reserved.</p>
22:10	Reserved
9	<p>SCR Access Enable (SCRAE) — R/W. In non-AHCI mode, this bit allows access to the SATA SCR registers (SStatus, SControl, and SError registers).</p> <p>0 = The ABAR (Dev31:F2:Offset 24h) register and MSE bit field (Dev31:F2:Offset 04h:bit 1) remain as defined. 1 = The ABAR (Dev31:F2:Offset 24h) register and MSE bit field (Dev31:F2:Offset 04h:bit 1) are forced to be read/write.</p> <p>NOTES:</p> <ol style="list-style-type: none"> Using this mode only allows access to AHCI registers PxSSTS, PxSCRTL, PxSERR. All other AHCI space is reserved when this bit is set. Proper use of this bit requires: <ul style="list-style-type: none"> ABAR must be programmed to a valid BAR; MSE must be set before software can access AHCI space. The Port Implemented bit (D31:F2, Offset ABAR+0Ch) for the corresponding port has to be set to allow access to the AHCI port specific PxSSTS, PxSCRTL, and PxSERR registers.
8:0	<p>SATA Initialization Field 1 (SIF1) — R/W. BIOS shall always program this register to the value 182h. All other values are reserved.</p>

12.1.32 SIRI—SATA Indexed Registers Index

Address Offset: A0h Attribute: R/W
Default Value: 00h Size: 8 bits

Bit	Description
7	Reserved
6:2	Index (IDX) — R/W. This field is a 5-bit index pointer into the SATA Indexed Register space. Data is written into and read from the SIRD register (D31:F2:A4h).
1:0	Reserved

Table 12-1. SATA Indexed Registers

Index	Name
00h–03h	SATA TX Termination Test Register 1 (STTT1)
04h–17h	Reserved
18h–1Bh	SATA Initialization Register 18 (SIR18)
1Ch–1Fh	SATA Test Mode Enable Register (STME)
20h–27h	Reserved
28h–2Bh	SATA Initialization Register 28 (SIR28)
2Bh–73h	Reserved
74h–77h	SATA TX Termination Test Register 2 (STTT2)
78h–83h	Reserved
84h–87h	SATA Initialization Register 84 (SIR84)
88h–FFh	Reserved

12.1.33 STRD—SATA Indexed Register Data

Address Offset: A4h Attribute: R/W
Default Value: XXXXXXXXh Size: 32 bits

Bit	Description
31:0	Data (DTA) — R/W. This field is a 32-bit data value that is written to the register pointed to by SIRI (D31:F2:A0h) or read from the register pointed to by SIRI.

12.1.34 STTT1—SATA Indexed Registers Index 00h (SATA TX Termination Test Register 1)

Address Offset: Index 00h - 03h Attribute: R/W
 Default Value: 00000000h Size: 32 bits

Bit	Description
31:2	Reserved.
1	<p>Port 1 TX Termination Test Enable — R/W: 0 = Port 1 TX termination port testing is disabled. 1 = Setting this bit will enable testing of Port 1 TX termination.</p> <p>NOTE: This bit only to be used for system board testing.</p>
0	<p>Port 0 TX Termination Test Enable — R/W: 0 = Port 0 TX termination port testing is disabled. 1 = Setting this bit will enable testing of Port 0 TX termination.</p> <p>NOTE: This bit only to be used for system board testing.</p>

12.1.35 SIR18—SATA Indexed Registers Index 18h (SATA Initialization Register 18h)

Address Offset: Index 18h - 01Bh Attribute: R/W
 Default Value: 0000025Bh Size: 32 bits

Bit	Description
31:6	Reserved.
5:0	BIOS programs this field to 101101b.

12.1.36 STME—SATA Indexed Registers Index 1Ch (SATA Test Mode Enable Register)

Address Offset: Index 1Ch - 1Fh Attribute: R/W
 Default Value: 00000000h Size: 32 bits

Bit	Description
31:19	Reserved.
18	<p>SATA Test Mode Enable Bit — R/W: 0 = Entrance to Intel ICH6 SATA test modes are disabled. 1 = This bit allows entrance to Intel ICH6 SATA test modes when set.</p> <p>Note: This bit only to be used for system board testing.</p>
17:0	Reserved.

12.1.37 SIR28—SATA Indexed Registers Index 28h (SATA Initialization Register 28h)

Address Offset: Index 28h - 2Bh Attribute: R/W
 Default Value: 00CC2080h Size: 32 bits

Bit	Description
31:23	Reserved.
22	BIOS leaves this bit at default.
21:19	Reserved
18	BIOS leaves this bit at default.
17:0	Reserved.

12.1.38 STTT2—SATA Indexed Registers Index 74h (SATA TX Termination Test Register 2)

Address Offset: Index 74h - 77h Attribute: R/W
 Default Value: 00000000h Size: 32 bits

Bit	Description
31:18	Reserved.
17	<p>Port 3 TX Termination Test Enable — R/W: 0 = Port 3 TX termination port testing is disabled. 1 = Setting this bit will enable testing of Port 3 TX termination.</p> <p>NOTE: This bit only to be used for system board testing.</p>
16	<p>Port 2 TX Termination Test Enable — R/W: 0 = Port 2TX termination port testing is disabled. 1 = Setting this bit will enable testing of Port 2TX termination.</p> <p>NOTE: This bit only to be used for system board testing.</p>
15:0	Reserved.

12.1.39 SIR84—SATA Indexed Registers Index 84h (SATA Initialization Register 84h)

Address Offset: Index 84h - 87h Attribute: R/W
 Default Value: 0000001Bh Size: 32 bits

Bit	Description
31:6	Reserved.
5:0	BIOS programs this field to 101101b.

12.1.40 ATC—APM Trapping Control Register (SATA–D31:F2)

Address Offset: C0h Attribute: R/W
 Default Value: 00h Size: 8 bits

Bit	Description
7:4	Reserved
3	Secondary Slave Trap (SST) — R/W. This bit enables trapping and SMI# assertion on legacy I/O accesses to 170h–177h and 376h. The active device on the secondary interface must be device 1 for the trap and/or SMI# to occur.
2	Secondary Master Trap (SPT) — R/W. This bit enables trapping and SMI# assertion on legacy I/O accesses to 170h–177h and 376h. The active device on the secondary interface must be device 0 for the trap and/or SMI# to occur.
1	Primary Slave Trap (PST) — R/W. This bit enables trapping and SMI# assertion on legacy I/O accesses to 1F0h–1F7h and 3F6h. The active device on the primary interface must be device 1 for the trap and/or SMI# to occur.
0	Primary Master Trap (PMT) — R/W. This bit enables trapping and SMI# assertion on legacy I/O accesses to 1F0h–1F7h and 3F6h. The active device on the primary interface must be device 0 for the trap and/or SMI# to occur.



12.1.41 ATS—APM Trapping Status Register (SATA—D31:F2)

Address Offset: C4h Attribute: R/W/C
 Default Value: 00h Size: 8 bits

Bit	Description
7:4	Reserved
3	Secondary Slave Trap (SST) — R/W/C. This bit indicates that a trap occurred to the secondary slave device.
2	Secondary Master Trap (SPT) — R/W/C. This bit indicates that a trap occurred to the secondary master device.
1	Primary Slave Trap (PST) — R/W/C. This bit indicates that a trap occurred to the primary slave device.
0	Primary Master Trap (PMT) — R/W/C. This bit indicates that a trap occurred to the primary master device.

12.1.42 SP—Scratch Pad Register (SATA—D31:F2)

Address Offset: D0h Attribute: R/W
 Default Value: 00000000h Size: 32 bits

Bit	Description
31:0	Data (DT) — R/W. This is a read/write register that is available for software to use. No hardware action is taken on this register.

12.1.43 BFCS—BIST FIS Control/Status Register (SATA—D31:F2)

Address Offset: E0h–E3h Attribute: R/W, R/W/C
 Default Value: 00000000h Size: 32 bits

Bits	Description
31:14	Reserved
13 (Desktop Only)	Port 3 BIST FIS Initiate (P3BFI) — R/W. When a rising edge is detected on this bit field, the ICH6 initiates a BIST FIS to the device on Port 3, using the parameters specified in this register and the data specified in BFTD1 and BFTD2. The BIST FIS will only be initiated if a device on Port 3 is present and ready (not partial/slumber state). After a BIST FIS is successfully completed, software must disable and re-enable the port using the PxE bits at offset 92h prior to attempting additional BIST FISes or to return the ICH6 to a normal operational mode. If the BIST FIS fails to complete, as indicated by the BFF bit in the register, then software can clear then set the P3BFI bit to initiate another BIST FIS. This can be retried until the BIST FIS eventually completes successfully.
13 (Mobile Only)	Reserved.
12	Port 2 BIST FIS Initiate (P2BFI) — R/W. When a rising edge is detected on this bit field, the ICH6 initiates a BIST FIS to the device on Port 2, using the parameters specified in this register and the data specified in BFTD1 and BFTD2. The BIST FIS will only be initiated if a device on Port 2 is present and ready (not partial/slumber state). After a BIST FIS is successfully completed, software must disable and re-enable the port using the PxE bits at offset 92h prior to attempting additional BIST FISes or to return the ICH6 to a normal operational mode. If the BIST FIS fails to complete, as indicated by the BFF bit in the register, then software can clear then set the P2BFI bit to initiate another BIST FIS. This can be retried until the BIST FIS eventually completes successfully.

Bits	Description
11	<p>BIST FIS Successful (BFS) — R/WC. 0 = Software clears this bit by writing a 1 to it. 1 = This bit is set any time a BIST FIS transmitted by ICH6 receives an R_OK completion status from the device.</p> <p>NOTE: This bit must be cleared by software prior to initiating a BIST FIS.</p>
10	<p>BIST FIS Failed (BFF) — R/WC. 0 = Software clears this bit by writing a 1 to it. 1 = This bit is set any time a BIST FIS transmitted by ICH6 receives an R_ERR completion status from the device.</p> <p>NOTE: This bit must be cleared by software prior to initiating a BIST FIS.</p>
9 (Desktop Only)	<p>Port 1 BIST FIS Initiate (P1BFI) — R/W. When a rising edge is detected on this bit field, the ICH6 initiates a BIST FIS to the device on Port 1, using the parameters specified in this register and the data specified in BFTD1 and BFTD2. The BIST FIS will only be initiated if a device on Port 1 is present and ready (not partial/slumber state). After a BIST FIS is successfully completed, software must disable and re-enable the port using the PxE bits at offset 92h prior to attempting additional BIST FISes or to return the ICH6 to a normal operational mode. If the BIST FIS fails to complete, as indicated by the BFF bit in the register, then software can clear then set the P1BFI bit to initiate another BIST FIS. This can be retried until the BIST FIS eventually completes successfully.</p>
9 (Mobile Only)	Reserved.
8	<p>Port 0 BIST FIS Initiate (P0BFI) — R/W. When a rising edge is detected on this bit field, the ICH6 initiates a BIST FIS to the device on Port 0, using the parameters specified in this register and the data specified in BFTD1 and BFTD2. The BIST FIS will only be initiated if a device on Port 0 is present and ready (not partial/slumber state). After a BIST FIS is successfully completed, software must disable and re-enable the port using the PxE bits at offset 92h prior to attempting additional BIST FISes or to return the ICH6 to a normal operational mode. If the BIST FIS fails to complete, as indicated by the BFF bit in the register, then software can clear then set the P0BFI bit to initiate another BIST FIS. This can be retried until the BIST FIS eventually completes successfully.</p>
7:2	<p>BIST FIS Parameters. These 6 bits form the contents of the upper 6 bits of the BIST FIS Pattern Definition in any BIST FIS transmitted by the ICH6. This field is not port specific — its contents will be used for any BIST FIS initiated on port 0, port 1, port 2 or port 3. The specific bit definitions are:</p> <p>Bit 7: T – Far End Transmit mode Bit 6: A – Align Bypass mode Bit 5: S – Bypass Scrambling Bit 4: L – Far End Retimed Loopback Bit 3: F – Far End Analog Loopback Bit 2: P – Primitive bit for use with Transmit mode</p>
1:0	Reserved

12.1.44 BFTD1—BIST FIS Transmit Data1 Register (SATA–D31:F2)

Address Offset: E4h–E7h Attribute: R/W
 Default Value: 00000000h Size: 32 bits

Bits	Description
31:0	BIST FIS Transmit Data 1 — R/W. The data programmed into this register will form the contents of the second DWord of any BIST FIS initiated by the ICH6. This register is not port specific — its contents will be used for BIST FIS initiated on any port. Although the 2nd and 3rd DWs of the BIST FIS are only meaningful when the “T” bit of the BIST FIS is set to indicate “Far-End Transmit mode”, this register’s contents will be transmitted as the BIST FIS 2nd DW regardless of whether or not the “T” bit is indicated in the BFCS register (D31:F2:E0h).

12.1.45 BFTD2—BIST FIS Transmit Data2 Register (SATA–D31:F2)

Address Offset: E8h–EBh Attribute: R/W
 Default Value: 00000000h Size: 32 bits

Bits	Description
31:0	BIST FIS Transmit Data 2 — R/W. The data programmed into this register will form the contents of the third DWord of any BIST FIS initiated by the ICH6. This register is not port specific — its contents will be used for BIST FIS initiated on any port. Although the 2nd and 3rd DWs of the BIST FIS are only meaningful when the “T” bit of the BIST FIS is set to indicate “Far-End Transmit mode”, this register’s contents will be transmitted as the BIST FIS 3rd DW regardless of whether or not the “T” bit is indicated in the BFCS register (D31:F2:E0h).

12.2 Bus Master IDE I/O Registers (D31:F2)

The bus master IDE function uses 16 bytes of I/O space, allocated via the BAR register, located in Device 31:Function 2 Configuration space, offset 20h. All bus master IDE I/O space registers can be accessed as byte, word, or DWord quantities. Reading reserved bits returns an indeterminate, inconsistent value, and writes to reserved bits have no affect (but should not be attempted). These registers are only used for legacy operation. Software must not use these registers when running AHCI. The description of the I/O registers is shown in [Table 12-2](#).

Table 12-2. Bus Master IDE I/O Register Address Map

BAR+ Offset	Mnemonic	Register	Default	Type
00	BMICP	Command Register Primary	00h	R/W
01	—	Reserved	—	RO
02	BMISP	Bus Master IDE Status Register Primary	00h	R/W, R/WC, RO
03	—	Reserved	—	RO
04–07	BMIDP	Bus Master IDE Descriptor Table Pointer Primary	xxxxxxxh	R/W
08	BMICS	Command Register Secondary	00h	R/W
09	—	Reserved	—	RO
0A	BMISS	Bus Master IDE Status Register Secondary	00h	R/W, R/WC, RO
0B	—	Reserved	—	RO
0C–0F	BMIDS	Bus Master IDE Descriptor Table Pointer Secondary	xxxxxxxh	R/W

12.2.1 BMIC[P,S]—Bus Master IDE Command Register (D31:F2)

Address Offset: Primary: BAR + 00h Attribute: R/W
 Secondary: BAR + 08h
 Default Value: 00h Size: 8 bits

Bit	Description
7:4	Reserved. Returns 0.
3	Read / Write Control (RWC) — R/W. This bit sets the direction of the bus master transfer: This bit must NOT be changed when the bus master function is active. 0 = Memory reads 1 = Memory writes
2:1	Reserved. Returns 0.
0	Start/Stop Bus Master (START) — R/W. 0 = All state information is lost when this bit is cleared. Master mode operation cannot be stopped and then resumed. If this bit is reset while bus master operation is still active (i.e., the Bus Master IDE Active bit (D31:F2:BAR + 02h, bit 0) of the Bus Master IDE Status register for that IDE channel is set) and the drive has not yet finished its data transfer (the Interrupt bit in the Bus Master IDE Status register for that IDE channel is not set), the bus master command is said to be aborted and data transferred from the drive may be discarded instead of being written to system memory. 1 = Enables bus master operation of the controller. Bus master operation does not actually start unless the Bus Master Enable bit (D31:F1:04h, bit 2) in PCI configuration space is also set. Bus master operation begins when this bit is detected changing from 0 to 1. The controller will transfer data between the IDE device and memory only when this bit is set. Master operation can be halted by writing a 0 to this bit. NOTE: This bit is intended to be cleared by software after the data transfer is completed, as indicated by either the Bus Master IDE Active bit being cleared or the Interrupt bit of the Bus Master IDE Status register for that IDE channel being set, or both. Hardware does not clear this bit automatically. If this bit is cleared to 0 prior to the DMA data transfer being initiated by the drive in a device to memory data transfer, then the ICH6 will not send DMAT to terminate the data transfer. SW intervention (e.g. sending SRST) is required to reset the interface in this condition.

12.2.2 BMIS[P,S]—Bus Master IDE Status Register (D31:F2)

Address Offset: Primary: BAR + 02h Attribute: R/W, R/WC, RO
 Secondary: BAR + 0Ah
 Default Value: 00h Size: 8 bits

Bit	Description
7	PRD Interrupt Status (PRDIS) — R/WC. 0 = Software clears this bit by writing a 1 to it. 1 = This bit is set when the host controller execution of a PRD that has its PRD_INT bit set.
6	Drive 1 DMA Capable — R/W. 0 = Not Capable. 1 = Capable. Set by device dependent code (BIOS or device driver) to indicate that drive 1 for this channel is capable of DMA transfers, and that the controller has been initialized for optimum performance. The Intel® ICH6 does not use this bit. It is intended for systems that do not attach BMIDE to the PCI bus.
5	Drive 0 DMA Capable — R/W. 0 = Not Capable 1 = Capable. Set by device dependent code (BIOS or device driver) to indicate that drive 0 for this channel is capable of DMA transfers, and that the controller has been initialized for optimum performance. The ICH6 does not use this bit. It is intended for systems that do not attach BMIDE to the PCI bus.
4:3	Reserved. Returns 0.
2	Interrupt — R/WC. 0 = Software clears this bit by writing a 1 to it. 1 = Set when a device FIS is received with the 'I' bit set, provided that software has not disabled interrupts via the nIEN bit of the Device Control Register (see chapter 5 of the <i>Serial ATA Specification</i> , Revision 1.0a).
1	Error — R/WC. 0 = Software clears this bit by writing a 1 to it. 1 = This bit is set when the controller encounters a target abort or master abort when transferring data on PCI.
0	Bus Master IDE Active (ACT) — RO. 0 = This bit is cleared by the ICH6 when the last transfer for a region is performed, where EOT for that region is set in the region descriptor. It is also cleared by the ICH6 when the Start Bus Master bit (D31:F2:BAR+ 00h, bit 0) is cleared in the Command register. When this bit is read as a 0, all data transferred from the drive during the previous bus master command is visible in system memory, unless the bus master command was aborted. 1 = Set by the ICH6 when the Start bit is written to the Command register.

12.2.3 BMID[P,S]—Bus Master IDE Descriptor Table Pointer Register (D31:F2)

Address Offset: Primary: BAR + 04h–07h Attribute: R/W
 Secondary: BAR + 0Ch–0Fh
 Default Value: All bits undefined Size: 32 bits

Bit	Description
31:2	Address of Descriptor Table (ADDR) — R/W. The bits in this field correspond to A[31:2]. The Descriptor Table must be dword-aligned. The Descriptor Table must not cross a 64-K boundary in memory.
1:0	Reserved

12.3 AHCI Registers (D31:F2)

Note: These registers are AHCI-specific and available only on ICH6R and ICH6-M when properly configured. The Serial ATA Status, Control, and Error registers are special exceptions and may be accessed on all ICH6 components if properly configured; see [Section 12.1.31](#) for details.

The memory mapped registers within the SATA controller exist in non-cacheable memory space. Additionally, locked accesses are not supported. If software attempts to perform locked transactions to the registers, indeterminate results may occur. Register accesses shall have a maximum size of 64-bits; 64-bit access must not cross an 8-byte alignment boundary.

The registers are broken into two sections – generic host control and port control. The port control registers are the same for all ports, and there are as many registers banks as there are ports.

Table 12-3. AHCI Register Address Map

ABAR + Offset	Mnemonic	Register
00h–1Fh	GHC	Generic Host Control
20h–FFh	—	Reserved
100h–17Fh	P0PCR	Port 0 port control registers
180h–1FFh	P1PCR	Port 1 port control registers (Desktop Only) Registers are not available and software must not read or write registers. (Mobile Only)
200h–27Fh	P2PCR	Port 2 port control registers
280h–2FFh	P3PCR	Port 3 port control registers (Desktop Only) Registers are not available and software must not read or write registers. (Mobile Only)
300h–3FFh	—	Reserved

12.3.1 AHCI Generic Host Control Registers (D31:F2)

Table 12-4. Generic Host Controller Register Address Map

ABAR + Offset	Mnemonic	Register	Default	Type
00h–03h	CAP	Host Capabilities	C6027F03h	R/WO, RO
04h–07h	GHC	Global ICH6 Control	00000000h	R/W
08h–0Bh	IS	Interrupt Status	00000000h	R/WC, RO
0Ch–0Fh	PI	Ports Implemented	00000000h	R/WO, RO
10h–13h	VS	AHCI Version	00010000h	RO

12.3.1.1 CAP—Host Capabilities Register (D31:F2)

Address Offset: ABAR + 00h–03h Attribute: R/WO, RO
 Default Value: C6027F03h Size: 32 bits

All bits in this register that are R/WO are reset only by PLTRST#.

Bit	Description
31	Supports 64-bit Addressing (S64A) — RO. This bit indicates that the SATA controller can access 64-bit data structures. The 32-bit upper bits of the port DMA Descriptor, the PRD Base, and each PRD entry are read/write.
30	Supports Command Queue Acceleration (SCQA) — RO. Hardwired to 1 to indicate that the SATA controller supports SATA command queuing via the DMA Setup FIS. The Intel® ICH6 handles DMA Setup FISes natively, and can handle auto-activate optimization through that FIS.
29	Supports Cold Presence Detect (SCD) — RO. Cold presence detect not supported.
28	Supports Interlock Switch (SIS) — R/WO. This bit indicates whether the SATA controller supports interlock switches on its ports for use in Hot-Plug operations. This value is loaded by platform BIOS prior to OS initialization. If this bit is set, BIOS must also map the SATAGP pins to the SATA controller through GPIO space.
27	Supports Staggered Spin-up (SSS) — R/WO. This bit indicates whether the SATA controller supports staggered spin-up on its ports, for use in balancing power spikes. This value is loaded by platform BIOS prior to OS initialization. 0 = Staggered spin-up not supported. 1 = Staggered spin-up supported.
26	Supports Aggressive Link Power Management (SALP) — R/W. 0 = Indicates that the SATA controller does not support auto-generating link requests to the partial or slumber states when there are no commands to process. 1 = Indicates that the SATA controller supports auto-generating link requests to the partial or slumber states when there are no commands to process. Note: For only B-1 step devices, BIOS must clear this bit.
25	Supports Activity LED (SAL) — RO. This field indicates that the SATA controller supports a single output pin (SATALED#) which indicates activity.
24	Supports Raw FIS Mode (SRM) — RO. The SATA controller does not support raw FIS mode.
23:20	Interface Speed Support (ISS) — RO. This field indicates the maximum speed the SATA controller can support on its ports. 0h = 1.5 Gb/s.
19	Supports Non-Zero DMA Offsets (SNZO) — RO. Reserved, as per the AHCI Revision 1.0 specification
18	Supports Port Selector Acceleration — RO. Port Selectors not supported.
17	Supports Port Multiplier (PMS) — R/WO. ICH6 does not support port multiplier. BIOS/SW shall write this bit to '0' during AHCI initialization.
16	Supports Port Multiplier FIS Based Switching (PMFS) — RO. Reserved, as per the AHCI Revision 1.0 specification.
15	Reserved. Returns 0.
14	Slumber State Capable (SSC) — RO. The SATA controller supports the slumber state.
13	Partial State Capable (PSC) — RO. The SATA controller supports the partial state.
12:8	Number of Command Slots (NCS) — RO. Hardwired to 1Fh to indicate support for 32 slots.
7:5	Reserved. Returns 0.
4:0	Number of Ports (NPS) — RO. Hardwired to 3h to indicate support for 4 ports. Note that the number of ports indicated in this field may be more than the number of ports indicated in the PI (ABAR + 0Ch) register.

12.3.1.2 GHC—Global ICH6 Control Register (D31:F2)

Address Offset: ABAR + 04h–07h Attribute: R/W
 Default Value: 00000000h Size: 32 bits

Bit	Description
31	<p>AHCI Enable (AE) — R/W. When set, this bit indicates that an AHCI driver is loaded and the controller will be talked to via AHCI mechanisms. This can be used by an ICH6 that supports both legacy mechanisms (such as SFF-8038i) and AHCI to know when the controller will not be talked to as legacy.</p> <p>When set, software will only talk to the ICH6 using AHCI. The ICH6 will not have to allow command processing via both AHCI and legacy mechanisms. When cleared, software will only talk to the ICH6 using legacy mechanisms.</p> <p>Software shall set this bit to 1 before accessing other AHCI registers.</p>
30:2	Reserved. Returns 0.
1	<p>Interrupt Enable (IE) — R/W. This global bit enables interrupts from the ICH6.</p> <p>0 = All interrupt sources from all ports are disabled. 1 = Interrupts are allowed from the AHCI controller.</p>
0	<p>HBA Reset (HR) — R/W. Resets ICH6 AHCI controller.</p> <p>0 = No effect 1 = When set by SW, this bit causes an internal reset of the ICH6 AHCI controller. All state machines that relate to data transfers and queuing return to an idle condition, and all ports are re-initialized via COMRESET.</p> <p>NOTE: For further details, consult section 12.3.3 of the <i>Serial ATA Advanced Host Controller Interface</i> specification.</p>

12.3.1.3 IS—Interrupt Status Register (D31:F2)

Address Offset: ABAR + 08h–0Bh Attribute: R/WC, RO
 Default Value: 00000000h Size: 32 bits

This register indicates which of the ports within the controller have an interrupt pending and require service.

Bit	Description
31:4	Reserved. Returns 0.
3 (Mobile Only)	Reserved. Returns 0.
3 (Desktop Only)	Interrupt Pending Status Port[3] (IPS[3]) — R/WC. 0 = No interrupt pending. 1 = Port 3 has an interrupt pending. Software can use this information to determine which ports require service after an interrupt.
2	Interrupt Pending Status Port[2] (IPS[2]) — R/WC 0 = No interrupt pending. 1 = Port 2 has an interrupt pending. Software can use this information to determine which ports require service after an interrupt.
1 (Mobile Only)	Reserved. Returns 0.
1 (Desktop Only)	Interrupt Pending Status Port[1] (IPS[1]) — R/WC. 0 = No interrupt pending. 1 = Port 1 has an interrupt pending. Software can use this information to determine which ports require service after an interrupt.
0	Interrupt Pending Status Port[0] (IPS[0]) — R/WC. 0 = No interrupt pending. 1 = Port 0 has an interrupt pending. Software can use this information to determine which ports require service after an interrupt.

12.3.1.4 PI—Ports Implemented Register (D31:F2)

Address Offset: ABAR + 0Ch–0Fh Attribute: R/WO, RO
 Default Value: 00000000h Size: 32 bits

This register indicates which ports are exposed to the ICH6. It is loaded by platform BIOS. It indicates which ports that the device supports are available for software to use. For ports that are not available, software must not read or write to registers within that port.

Bit	Description
31:4	Reserved. Returns 0.
3 (Desktop Only)	Ports Implemented Port 3 (PI3) — R/WO. 0 = The port is not implemented. 1 = The port is implemented.
3 (Mobile Only)	Ports Implemented Port 3 (PI3) — RO. 0 = The port is not implemented.
2	Ports Implemented Port 2 (PI2) — R/WO. 0 = The port is not implemented. 1 = The port is implemented.
1 (Desktop Only)	Ports Implemented Port 1 (PI1) — R/WO. 0 = The port is not implemented. 1 = The port is implemented.
1 (Mobile Only)	Ports Implemented Port 1 (PI1) — RO. 0 = The port is not implemented.
0	Ports Implemented Port 0 (PI0) — R/WO. 0 = The port is not implemented. 1 = The port is implemented.

12.3.1.5 VS—AHCI Version (D31:F2)

Address Offset: ABAR + 10h–13h Attribute: RO
 Default Value: 00010000h Size: 32 bits

This register indicates the major and minor version of the AHCI specification. It is BCD encoded. The upper two bytes represent the major version number, and the lower two bytes represent the minor version number. Example: Version 3.12 would be represented as 00030102h. The current version of the specification is 1.0 (00010000h).

Bit	Description
31:16	Major Version Number (MJR) — RO. This field indicates the major version is 1
15:0	Minor Version Number (MNR) — RO. This field indicates the minor version is 0.

12.3.2 Port Registers (D31:F2)

Table 12-5. Port [3:0] DMA Register Address Map

ABAR + Offset	Mnemonic	Register
100–103h	P0CLB	Port 0 Command List Base Address
104–107h	P0CLBU	Port 0 Command List Base Address Upper 32-Bits
108–10Bh	P0FB	Port 0 FIS Base Address
10C–10Fh	P0FBU	Port 0 FIS Base Address Upper 32-Bits
110–113h	P0IS	Port 0 Interrupt Status
114–117h	P0IE	Port 0 Interrupt Enable
118–11Ch	P0CMD	Port 0 Command
11C–11Fh	—	Reserved
120–123h	P0TFD	Port 0 Task File Data
124–127h	P0SIG	Port 0 Signature
128–12Bh	P0SSTS	Port 0 Serial ATA Status
12C–12Fh	P0SCTL	Port 0 Serial ATA Control
130–133h	P0SERR	Port 0 Serial ATA Error
134–137h	P0SACT	Port 0 Serial ATA Active
138–13Bh	P0CI	Port 0 Command Issue
13C–17Fh	—	Reserved
180–1FFh (Mobile Only)	—	Reserved Registers are not available and software must not read from or write to registers.
180–183h	P1CLB	Port 1 Command List Base Address
184–187h	P1CLBU	Port 1 Command List Base Address Upper 32-Bits
188–18Bh	P1FB	Port 1 FIS Base Address
18C–18Fh	P1FBU	Port 1 FIS Base Address Upper 32-Bits
190–193h	P1IS	Port 1 Interrupt Status
194–197h	P1IE	Port 1 Interrupt Enable
198–19Ch	P1CMD	Port 1 Command
19C–19Fh	—	Reserved
1A0–1A3h	P1TFD	Port 1 Task File Data
1A4–1A7h	P1SIG	Port 1 Signature
1A8–1ABh	P1SSTS	Port 1 Serial ATA Status
1AC–1AFh	P1SCTL	Port 1 Serial ATA Control
1B0–1B3h	P1SERR	Port 1 Serial ATA Error
1B4–1B7h	P1SACT	Port 1 Serial ATA Active
1B8–1BBh	P1CI	Port 1 Command Issue
1BC–1FFh	—	Reserved

Table 12-5. Port [3:0] DMA Register Address Map

ABAR + Offset	Mnemonic	Register
200–203h	P2CLB	Port 2 Command List Base Address
204–207h	P2CLBU	Port 2 Command List Base Address Upper 32-Bits
208–20Bh	P2FB	Port 2 FIS Base Address
20C–20Fh	P2FBU	Port 2 FIS Base Address Upper 32-Bits
210–213h	P2IS	Port 2 Interrupt Status
214–217h	P2IE	Port 2 Interrupt Enable
218–21Ch	P2CMD	Port 2 Command
21C–21Fh	—	Reserved
220–223h	P2TFD	Port 2 Task File Data
224–227h	P2SIG	Port 2 Signature
228–22Bh	P2SSTS	Port 2 Serial ATA Status
22C–22Fh	P2SCTL	Port 2 Serial ATA Control
230–233h	P2SERR	Port 2 Serial ATA Error
234–237h	P2SACT	Port 2 Serial ATA Active
238–23Bh	P2CI	Port 2 Command Issue
23C–27Fh	—	Reserved
280–2FFh (Mobile Only)	—	Reserved Registers are not available and software must not read from or write to registers.
280–283h	P3CLB	Port 3 Command List Base Address
284–287h	P3CLBU	Port 3 Command List Base Address Upper 32-Bits
288–28Bh	P3FB	Port 3 FIS Base Address
28C–28Fh	P3FBU	Port 3 FIS Base Address Upper 32-Bits
290–293h	P3IS	Port 3 Interrupt Status
294–297h	P3IE	Port 3 Interrupt Enable
298–29Ch	P3CMD	Port 3 Command
19C–19Fh	—	Reserved
2A0–2A3h	P3TFD	Port 3 Task File Data
2A4–2A7h	P3SIG	Port 3 Signature
2A8–2ABh	P3SSTS	Port 3 Serial ATA Status
2AC–2AFh	P3SCTL	Port 3 Serial ATA Control
2B0–2B3h	P3SERR	Port 3 Serial ATA Error
2B4–2B7h	P3SACT	Port 3 Serial ATA Active
2B8–2BBh	P3CI	Port 3 Command Issue
2BC–2FFh	—	Reserved

12.3.2.1 PxCLB—Port [3:0] Command List Base Address Register (D31:F2)

Address Offset: Port 0: ABAR + 100h Attribute: R/W, RO
 Port 1: ABAR + 180h (Desktop Only)
 Port 2: ABAR + 200h
 Port 3: ABAR + 280h (Desktop Only)
 Default Value: Undefined Size: 32 bits

Bit	Description
31:10	Command List Base Address (CLB) — R/W. This field indicates the 32-bit base for the command list for this port. This base is used when fetching commands to execute. The structure pointed to by this address range is 1 KB in length. This address must be 1-KB aligned as indicated by bits 31:10 being read/write. Note that these bits are not reset on a HBA reset.
9:0	Reserved — RO

12.3.2.2 PxCLBU—Port [3:0] Command List Base Address Upper 32-Bits Register (D31:F2)

Address Offset: Port 0: ABAR + 104h Attribute: R/W
 Port 1: ABAR + 184h (Desktop Only)
 Port 2: ABAR + 204h
 Port 3: ABAR + 284h (Desktop Only)
 Default Value: Undefined Size: 32 bits

Bit	Description
31:0	Command List Base Address Upper (CLBU) — R/W. This field indicates the upper 32-bits for the command list base address for this port. This base is used when fetching commands to execute. Note that these bits are not reset on a HBA reset.

12.3.2.3 PxFB—Port [3:0] FIS Base Address Register (D31:F2)

Address Offset: Port 0: ABAR + 108h Attribute: R/W, RO
 Port 1: ABAR + 188h (Desktop Only)
 Port 2: ABAR + 208h
 Port 3: ABAR + 288h (Desktop Only)
 Default Value: Undefined Size: 32 bits

Bit	Description
31:8	FIS Base Address (FB) — R/W. This field indicates the 32-bit base for received FISes. The structure pointed to by this address range is 256 bytes in length. This address must be 256-byte aligned, as indicated by bits 31:3 being read/write. Note that these bits are not reset on a HBA reset.
7:0	Reserved — RO

12.3.2.4 PxFBU—Port [3:0] FIS Base Address Upper 32-Bits Register (D31:F2)

Address Offset: Port 0: ABAR + 10Ch Attribute: R/W
 Port 1: ABAR + 18Ch
 Port 2: ABAR + 20Ch
 Port 3: ABAR + 28Ch
 Default Value: Undefined Size: 32 bits

Bit	Description
31:3	Command List Base Address Upper (CLBU) — R/W. This field indicates the upper 32-bits for the received FIS base for this port. Note that these bits are not reset on a HBA reset.
2:0	Reserved

12.3.2.5 PxIS—Port [3:0] Interrupt Status Register (D31:F2)

Address Offset: Port 0: ABAR + 110h Attribute: R/WC, RO
 Port 1: ABAR + 190h (Desktop Only)
 Port 2: ABAR + 210h
 Port 3: ABAR + 290h (Desktop Only)
 Default Value: 00000000h Size: 32 bits

Bit	Description
31	Cold Port Detect Status (CPDS) — RO. Cold presence not supported.
30	Task File Error Status (TFES) — R/WC. This bit is set whenever the status register is updated by the device and the error bit (PxTFD.bit 0) is set.
29	Host Bus Fatal Error Status (HBFS) — R/WC. This bit indicates that the Intel® ICH6 encountered an error that it cannot recover from due to a bad software pointer. In PCI, such an indication would be a target or master abort.
28	Host Bus Data Error Status (HBDS) — R/WC. Indicates that the ICH6 encountered a data error (uncorrectable ECC / parity) when reading from or writing to system memory.
27	Interface Fatal Error Status (IFS) — R/WC. Indicates that the ICH6 encountered an error on the SATA interface which caused the transfer to stop.
26	Interface Non-fatal Error Status (INFS) — R/WC. Indicates that the ICH6 encountered an error on the SATA interface but was able to continue operation.
25	Reserved
24	Overflow Status (OFS) — R/WC. Indicates that the ICH6 received more bytes from a device than was specified in the PRD table for the command.
23	Incorrect Port Multiplier Status (IPMS) — R/WC. Indicates that the ICH6 received a FIS from a device whose Port Multiplier field did not match what was expected. NOTE: Port Multiplier not supported by ICH6.
22	PhyRdy Change Status (PRCS) — RO. When set to 1 indicates the internal PhyRdy signal changed state. This bit reflects the state of PxSERR.DIAG.N. Unlike most of the other bits in the register, this bit is RO and is only cleared when PxSERR.DIAG.N is cleared. Note that the internal PhyRdy signal also transitions when the port interface enters partial or slumber power management states. Partial and slumber must be disabled when Surprise Removal Notification is desired, otherwise the power management state transitions will appear as false insertion and removal events.
21:8	Reserved

Bit	Description
7	Device Interlock Status (DIS) — R/WC. When set, indicates that a platform interlock switch has been opened or closed, which may lead to a change in the connection state of the device. This bit is only valid in systems that support an interlock switch (CAP.SIS [ABAR+00:bit 28] set). For systems that do not support an interlock switch, this bit will always be 0.
6	Port Connect Change Status (PCS) — RO. This bit reflects the state of PxSERR.DIAG.X. (ABAR+130h/1D0h/230h/2D0h, bit 26) Unlike other bits in this register, this bit is only cleared when PxSERR.DIAG.X is cleared. 0 = No change in Current Connect Status. 1 = Change in Current Connect Status.
5	Descriptor Processed (DPS) — R/WC. A PRD with the I bit set has transferred all its data.
4	Unknown FIS Interrupt (UFS) — RO. When set to '1' indicates that an unknown FIS was received and has been copied into system memory. This bit is cleared to '0' by software clearing the PxSERR.DIAG.F (ABAR+130h/1D0h/230h/2D0h, bit 25) bit to '0'. Note that this bit does not directly reflect the PxSERR.DIAG.F bit. PxSERR.DIAG.F is set immediately when an unknown FIS is detected, whereas this bit is set when the FIS is posted to memory. Software should wait to act on an unknown FIS until this bit is set to '1' or the two bits may become out of sync.
3	Set Device Bits Interrupt (SDBS) — R/WC. A Set Device Bits FIS has been received with the I bit set and has been copied into system memory.
2	DMA Setup FIS Interrupt (DSS) — R/WC. A DMA Setup FIS has been received with the I bit set and has been copied into system memory.
1	PIO Setup FIS Interrupt (PSS) — R/WC. A PIO Setup FIS has been received with the I bit set, it has been copied into system memory, and the data related to that FIS has been transferred.
0	Device to Host Register FIS Interrupt (DHRS) — R/WC. A D2H Register FIS has been received with the I bit set, and has been copied into system memory.

12.3.2.6 PxIE—Port [3:0] Interrupt Enable Register (D31:F2)

Address Offset:	Port 0: ABAR + 114h	Attribute:	R/W, RO
	Port 1: ABAR + 194h (Desktop Only)		
	Port 2: ABAR + 214h		
	Port 3: ABAR + 294h (Desktop Only)		
Default Value:	00000000h	Size:	32 bits

This register enables and disables the reporting of the corresponding interrupt to system software. When a bit is set ('1') and the corresponding interrupt condition is active, then an interrupt is generated. Interrupt sources that are disabled ('0') are still reflected in the status registers.

Bit	Description
31	Cold Presence Detect Enable (CPDE) — RO. Cold Presence Detect not supported.
30	Task File Error Enable (TFEE) — R/W. When set, and GHC.IE and PxTFD.STS.ERR (due to a reception of the error register from a received FIS) are set, the Intel® ICH6 will generate an interrupt.
29	Host Bus Fatal Error Enable (HBFE) — R/W. When set, and GHC.IE and PxS.HBFS are set, the ICH6 will generate an interrupt.
28	Host Bus Data Error Enable (HBDE) — R/W. When set, and GHC.IE and PxS.HBDS are set, the ICH6 will generate an interrupt.
27	Host Bus Data Error Enable (HBDE) — R/W. When set, GHC.IE is set, and PxIS.HBDS is set, the ICH6 will generate an interrupt.
26	Interface Non-fatal Error Enable (INFE) — R/W. When set, GHC.IE is set, and PxIS.INFS is set, the ICH6 will generate an interrupt.
25	Reserved - Should be written as 0
24	Overflow Error Enable (OFE) — R/W. When set, and GHC.IE and PxS.OFS are set, the ICH6 will generate an interrupt.
23	Incorrect Port Multiplier Enable (IPME) — R/W. When set, and GHC.IE and PxIS.IPMS are set, the ICH6 will generate an interrupt. NOTE: Should be written as 0. Port Multiplier not supported by ICH6.
22	PhyRdy Change Interrupt Enable (PRCE) — R/W. When set, and GHC.IE is set, and PxIS.PRCIS is set, the ICH6 shall generate an interrupt.
21:8	Reserved - Should be written as 0
7	Device Interlock Enable (DIE) — R/W. When set, and PxIS.DIS is set, the ICH6 will generate an interrupt. For systems that do not support an interlock switch, this bit shall be a read-only 0.
6	Port Change Interrupt Enable (PCE) — R/W. When set, and GHC.IE and PxS.PCS are set, the ICH6 will generate an interrupt.
5	Descriptor Processed Interrupt Enable (DPE) — R/W. When set, and GHC.IE and PxS.DPS are set, the ICH6 will generate an interrupt
4	Unknown FIS Interrupt Enable (UFIE) — R/W. When set, and GHC.IE is set and an unknown FIS is received, the ICH6 will generate this interrupt.
3	Set Device Bits FIS Interrupt Enable (SDBE) — R/W. When set, and GHC.IE and PxS.SDBS are set, the ICH6 will generate an interrupt.
2	DMA Setup FIS Interrupt Enable (DSE) — R/W. When set, and GHC.IE and PxS.DSS are set, the ICH6 will generate an interrupt.
1	PIO Setup FIS Interrupt Enable (PSE) — R/W. When set, and GHC.IE and PxS.PSS are set, the ICH6 will generate an interrupt.
0	Device to Host Register FIS Interrupt Enable (DHRE) — R/W. When set, and GHC.IE and PxS.DHRS are set, the ICH6 will generate an interrupt.

12.3.2.7 PxCMD—Port [3:0] Command Register (D31:F2)

Address Offset: Port 0: ABAR + 118h Attribute: R/W, RO, R/WO
 Port 1: ABAR + 198h (Desktop Only)
 Port 2: ABAR + 218h
 Port 3: ABAR + 298h (Desktop Only)
 Default Value: 0000w00wh Size: 32 bits
 where w = 00?0b (for ?, see bit description)

Bit	Description														
31:28	<p>Interface Communication Control (ICC) — R/W. This is a four bit field which can be used to control reset and power states of the interface. Writes to this field will cause actions on the interface, either as primitives or an OOB sequence, and the resulting status of the interface will be reported in the PxSSTS register (Address offset Port 0:ABAR+124h, Port 1: ABAR+1A4h, Port 2: ABAR+224h, Port 3: ABAR+2A4h).</p> <table border="1"> <thead> <tr> <th>Value</th> <th>Definition</th> </tr> </thead> <tbody> <tr> <td>Fh–7h</td> <td>Reserved</td> </tr> <tr> <td>6h</td> <td>Slumber: This will cause the Intel® ICH6 to request a transition of the interface to the slumber state. The SATA device may reject the request and the interface will remain in its current state</td> </tr> <tr> <td>5h–3h</td> <td>Reserved</td> </tr> <tr> <td>2h</td> <td>Partial: This will cause the ICH6 to request a transition of the interface to the partial state. The SATA device may reject the request and the interface will remain in its current state.</td> </tr> <tr> <td>1h</td> <td>Active: This will cause the ICH6 to request a transition of the interface into the active</td> </tr> <tr> <td>0h</td> <td>No-Op / Idle: When software reads this value, it indicates the ICH6 is not in the process of changing the interface state or sending a device reset, and a new link command may be issued.</td> </tr> </tbody> </table> <p>When system software writes a non-reserved value other than No-Op (0h), the ICH6 will perform the action and update this field back to Idle (0h). If software writes to this field to change the state to a state the link is already in (e.g. interface is in the active state and a request is made to go to the active state), the ICH6 will take no action and return this field to Idle. NOTE: When the ALPE bit (bit 26) is set, then this register should not be set to 02h or 06h.</p>	Value	Definition	Fh–7h	Reserved	6h	Slumber: This will cause the Intel® ICH6 to request a transition of the interface to the slumber state. The SATA device may reject the request and the interface will remain in its current state	5h–3h	Reserved	2h	Partial: This will cause the ICH6 to request a transition of the interface to the partial state. The SATA device may reject the request and the interface will remain in its current state.	1h	Active: This will cause the ICH6 to request a transition of the interface into the active	0h	No-Op / Idle: When software reads this value, it indicates the ICH6 is not in the process of changing the interface state or sending a device reset, and a new link command may be issued.
Value	Definition														
Fh–7h	Reserved														
6h	Slumber: This will cause the Intel® ICH6 to request a transition of the interface to the slumber state. The SATA device may reject the request and the interface will remain in its current state														
5h–3h	Reserved														
2h	Partial: This will cause the ICH6 to request a transition of the interface to the partial state. The SATA device may reject the request and the interface will remain in its current state.														
1h	Active: This will cause the ICH6 to request a transition of the interface into the active														
0h	No-Op / Idle: When software reads this value, it indicates the ICH6 is not in the process of changing the interface state or sending a device reset, and a new link command may be issued.														
27	<p>Aggressive Slumber / Partial (ASP) — R/W. When set, and the ALPE bit (bit 26) is set, the ICH6 will aggressively enter the slumber state when it clears the PxCI register and the PxSACT register is cleared. When cleared, and the ALPE bit is set, the ICH6 will aggressively enter the partial state when it clears the PxCI register and the PxSACT register is cleared.</p>														
26	<p>Aggressive Link Power Management Enable (ALPE) — R/W. When set, the ICH6 will aggressively enter a lower link power state (partial or slumber) based upon the setting of the ASP bit (bit 27).</p>														
25	<p>Drive LED on ATAPI Enable (DLAE) — R/W. When set, the ICH6 will drive the LED pin active for ATAPI commands (PxCLB[CHz.A] set) in addition to ATA commands. When cleared, the ICH6 will only drive the LED pin active for ATA commands. See Section 5.17.5 for details on the activity LED.</p>														
24	<p>HDevice is ATAPI (ATAPI) — R/W. When set, the connected device is an ATAPI device. This bit is used by the ICH6 to control whether or not to generate the desktop LED when commands are active. See Section 5.17.5 for details on the activity LED.</p>														
23:20	Reserved														

Bit	Description
19	<p>Interlock Switch Attached to Port (ISP) — R/WO. When interlock switches are supported in the platform (CAP.SIS [ABAR+00h:bit 28] set), this indicates whether this particular port has an interlock switch attached. This bit can be used by system software to enable such features as aggressive power management, as disconnects can always be detected regardless of PHY state with an interlock switch. When this bit is set, it is expected that HPCP (bit 18) in this register is also set.</p> <p>The ICH6 takes no action on the state of this bit – it is for system software only. For example, if this bit is cleared, and an interlock switch toggles, the ICH6 still treats it as a proper interlock switch event.</p> <p>Note that these bits are not reset on a HBA reset.</p>
18	<p>Hot Plug Capable Port (HPCP) — R/WO.</p> <p>0 = Port is not capable of Hot-Plug. 1 = Port is Hot-Plug capable.</p> <p>This indicates whether the platform exposes this port to a device which can be Hot-Plugged. SATA by definition is hot-pluggable, but not all platforms are constructed to allow the device to be removed (it may be screwed into the chassis, for example). This bit can be used by system software to indicate a feature such as "eject device" to the end-user. The ICH6 takes no action on the state of this bit - it is for system software only. For example, if this bit is cleared, and a Hot-Plug event occurs, the ICH6 still treats it as a proper Hot-Plug event.</p> <p>Note that these bits are not reset on a HBA reset.</p>
17	<p>Port Multiplier Attached (PMA) — RO / R/W. When this bit is set, a port multiplier is attached to the ICH6 for this port. When cleared, a port multiplier is not attached to this port.</p> <p>This bit is RO 0 when CAP.PMS (offset ABAR+00h:bit 17) = 0 and R/W when CAP.PMS = 1.</p> <p>NOTE: Port Multiplier not supported by ICH6.</p>
16	<p>Port Multiplier FIS Based Switching Enable (PMFSE) — RO. The ICH6 does not support FIS-based switching.</p>
15	<p>Controller Running (CR) — RO. When this bit is set, the DMA engines for a port are running. See section 5.2.2 of the <i>Serial ATA AHCI Specification</i> for details on when this bit is set and cleared by the ICH6.</p>
14	<p>FIS Receive Running (FR) — RO. When set, the FIS Receive DMA engine for the port is running. See section 12.2.2 of the <i>Serial ATA AHCI Specification</i> for details on when this bit is set and cleared by the ICH6.</p>
13	<p>Interlock Switch State (ISS) — RO. For systems that support interlock switches (via CAP.SIS [ABAR+00h:bit 28]), if an interlock switch exists on this port (via ISP in this register), this bit indicates the current state of the interlock switch. A 0 indicates the switch is closed, and a 1 indicates the switch is opened.</p> <p>For systems that do not support interlock switches, or if an interlock switch is not attached to this port, this bit reports 0.</p>
12:8	<p>Current Command Slot (CCS) — RO. This field indicates the current command slot the ICH6 is processing. This field is valid when the ST bit is set in this register, and is constantly updated by the ICH6. This field can be updated as soon as the ICH6 recognizes an active command slot, or at some point soon after when it begins processing the command.</p> <p>This field is used by software to determine the current command issue location of the ICH6. In queued mode, software shall not use this field, as its value does not represent the current command being executed. Software shall only use PxCI and PxSACT when running queued commands.</p>
7:5	Reserved
4	<p>FIS Receive Enable (FRE) — R/W. When set, the ICH6 may post received FISes into the FIS receive area pointed to by PxFB (ABAR+108h/188h/208h/288h) and PxFBU (ABAR+10Ch/18Ch/20Ch/28Ch). When cleared, received FISes are not accepted by the ICH6, except for the first D2H (device-to-host) register FIS after the initialization sequence.</p> <p>System software must not set this bit until PxFB (PxFBU) have been programmed with a valid pointer to the FIS receive area, and if software wishes to move the base, this bit must first be cleared, and software must wait for the FR bit (bit 14) in this register to be cleared.</p>
3	<p>Port Selector Activate (PSA) — RO. Port Selector not supported. Defaults to 0.</p>

Bit	Description
2	Power On Device (POD) — RO. Cold presence detect not supported. Defaults to 1.
1	<p>Spin-Up Device (SUD) — R/W / RO</p> <p>This bit is R/W and defaults to 0 for systems that support staggered spin-up (R/W when CAP.SSS (ABAR+00h:bit 27) is 1). Bit is RO 1 for systems that do not support staggered spin-up (when CAP.SSS is 0).</p> <p>0 = No action. 1 = On an edge detect from 0 to 1, the ICH6 starts a COMRESET initialization sequence to the device.</p>
0	<p>Start (ST) — R/W. When set, the ICH6 may process the command list. When cleared, the ICH6 may not process the command list. Whenever this bit is changed from a 0 to a 1, the ICH6 starts processing the command list at entry 0. Whenever this bit is changed from a 1 to a 0, the PxCI register is cleared by the ICH6 upon the ICH6 putting the controller into an idle state.</p> <p>Refer to section 12.2.1 of the Serial ATA AHCI Specification for important restrictions on when ST can be set to 1.</p>

12.3.2.8 PxTFD—Port [3:0] Task File Data Register (D31:F2)

Address Offset: Port 0: ABAR + 120h Attribute: RO
 Port 1: ABAR + 1A0h (Desktop Only)
 Port 2: ABAR + 220h
 Port 3: ABAR + 2A0h (Desktop Only)

Default Value: 0000007Fh Size: 32 bits

This is a 32-bit register that copies specific fields of the task file when FISes are received. The FISes that contain this information are:

- D2H Register FIS
- PIO Setup FIS
- Set Device Bits FIS

Bit	Description																		
31:16	Reserved																		
15:8	Error (ERR) — RO. Contains the latest copy of the task file error register.																		
7:0	<p>Status (STS) — RO. Contains the latest copy of the task file status register. Fields of note in this register that affect AHCI.</p> <table border="1"> <thead> <tr> <th>Bit</th> <th>Field</th> <th>Definition</th> </tr> </thead> <tbody> <tr> <td>7</td> <td>BSY</td> <td>Indicates the interface is busy</td> </tr> <tr> <td>6:4</td> <td>N/A</td> <td>Not applicable</td> </tr> <tr> <td>3</td> <td>DRQ</td> <td>Indicates a data transfer is requested</td> </tr> <tr> <td>2:1</td> <td>N/A</td> <td>Not applicable</td> </tr> <tr> <td>0</td> <td>ERR</td> <td>Indicates an error during the transfer</td> </tr> </tbody> </table>	Bit	Field	Definition	7	BSY	Indicates the interface is busy	6:4	N/A	Not applicable	3	DRQ	Indicates a data transfer is requested	2:1	N/A	Not applicable	0	ERR	Indicates an error during the transfer
	Bit	Field	Definition																
	7	BSY	Indicates the interface is busy																
	6:4	N/A	Not applicable																
	3	DRQ	Indicates a data transfer is requested																
2:1	N/A	Not applicable																	
0	ERR	Indicates an error during the transfer																	

12.3.2.9 PxSIG—Port [3:0] Signature Register (D31:F2)

Address Offset: Port 0: ABAR + 124h Attribute: RO
 Port 1: ABAR + 1A4h (Desktop Only)
 Port 2: ABAR + 224h
 Port 3: ABAR + 2A4h (Desktop Only)
 Default Value: FFFFFFFFh Size: 32 bits

This is a 32-bit register which contains the initial signature of an attached device when the first D2H Register FIS is received from that device. It is updated once after a reset sequence.

Bit	Description										
31:0	<p>Signature (SIG) — RO. This field contains the signature received from a device on the first D2H register FIS. The bit order is as follows:</p> <table border="1"> <thead> <tr> <th data-bbox="505 688 553 709">Bit</th> <th data-bbox="695 688 748 709">Field</th> </tr> </thead> <tbody> <tr> <td data-bbox="505 720 553 741">31:24</td> <td data-bbox="613 720 781 741">LBA High Register</td> </tr> <tr> <td data-bbox="505 751 553 772">23:16</td> <td data-bbox="613 751 776 772">LBA Mid Register</td> </tr> <tr> <td data-bbox="505 783 553 804">15:8</td> <td data-bbox="613 783 776 804">LBA Low Register</td> </tr> <tr> <td data-bbox="505 814 553 835">7:0</td> <td data-bbox="613 814 813 835">Sector Count Register</td> </tr> </tbody> </table>	Bit	Field	31:24	LBA High Register	23:16	LBA Mid Register	15:8	LBA Low Register	7:0	Sector Count Register
Bit	Field										
31:24	LBA High Register										
23:16	LBA Mid Register										
15:8	LBA Low Register										
7:0	Sector Count Register										

12.3.2.10 PxSSTS—Port [3:0] Serial ATA Status Register (D31:F2)

Address Offset: Port 0: ABAR + 128h Attribute: RO
 Port 1: ABAR + 1A8h (Desktop Only)
 Port 2: ABAR + 228h
 Port 3: ABAR + 2A8h (Desktop Only)
 Default Value: 00000000h Size: 32 bits

This is a 32-bit register that conveys the current state of the interface and host. The ICH6 updates it continuously and asynchronously. When the ICH6 transmits a COMRESET to the device, this register is updated to its reset values.

Bit	Description										
31:12	Reserved										
11:8	<p>Interface Power Management (IPM) — RO. This field indicates the current interface state:</p> <table border="1"> <thead> <tr> <th>Value</th> <th>Description</th> </tr> </thead> <tbody> <tr> <td>0h</td> <td>Device not present or communication not established</td> </tr> <tr> <td>1h</td> <td>Interface in active state</td> </tr> <tr> <td>2h</td> <td>Interface in PARTIAL power management state</td> </tr> <tr> <td>6h</td> <td>Interface in SLUMBER power management state</td> </tr> </tbody> </table> <p>All other values reserved.</p>	Value	Description	0h	Device not present or communication not established	1h	Interface in active state	2h	Interface in PARTIAL power management state	6h	Interface in SLUMBER power management state
Value	Description										
0h	Device not present or communication not established										
1h	Interface in active state										
2h	Interface in PARTIAL power management state										
6h	Interface in SLUMBER power management state										
7:4	<p>Current Interface Speed (SPD) — RO. This field indicates the negotiated interface communication speed.</p> <table border="1"> <thead> <tr> <th>Value</th> <th>Description</th> </tr> </thead> <tbody> <tr> <td>0h</td> <td>Device not present or communication not established</td> </tr> <tr> <td>1h</td> <td>Generation 1 communication rate negotiated</td> </tr> </tbody> </table> <p>All other values reserved.</p> <p>ICH6 Supports only Generation 1 communication rates (1.5 Gb/sec).</p>	Value	Description	0h	Device not present or communication not established	1h	Generation 1 communication rate negotiated				
Value	Description										
0h	Device not present or communication not established										
1h	Generation 1 communication rate negotiated										
3:0	<p>Device Detection (DET) — RO. This field indicates the interface device detection and Phy state:</p> <table border="1"> <thead> <tr> <th>Value</th> <th>Description</th> </tr> </thead> <tbody> <tr> <td>0h</td> <td>No device detected and Phy communication not established</td> </tr> <tr> <td>1h</td> <td>Device presence detected but Phy communication not established</td> </tr> <tr> <td>3h</td> <td>Device presence detected and Phy communication established</td> </tr> <tr> <td>4h</td> <td>Phy in offline mode as a result of the interface being disabled or running in a BIST loopback mode</td> </tr> </tbody> </table> <p>All other values reserved.</p>	Value	Description	0h	No device detected and Phy communication not established	1h	Device presence detected but Phy communication not established	3h	Device presence detected and Phy communication established	4h	Phy in offline mode as a result of the interface being disabled or running in a BIST loopback mode
Value	Description										
0h	No device detected and Phy communication not established										
1h	Device presence detected but Phy communication not established										
3h	Device presence detected and Phy communication established										
4h	Phy in offline mode as a result of the interface being disabled or running in a BIST loopback mode										

12.3.2.11 PxSCTL—Port [3:0] Serial ATA Control Register (D31:F2)

Address Offset:	Port 0: ABAR + 12Ch	Attribute:	R/W, RO
	Port 1: ABAR + 1ACh (Desktop Only)		
	Port 2: ABAR + 22Ch		
	Port 3: ABAR + 2ACh (Desktop Only)		
Default Value:	00000004h	Size:	32 bits

This is a 32-bit read-write register by which software controls SATA capabilities. Writes to the SControl register result in an action being taken by the ICH6 or the interface. Reads from the register return the last value written to it.

Bit	Description										
31:20	Reserved										
19:16	Port Multiplier Port (PMP) — RO. This field is not used by AHCI										
15:12	Select Power Management (SPM) — RO. This field is not used by AHCI										
11:8	<p>Interface Power Management Transitions Allowed (IPM) — R/W. This field indicates which power states the ICH6 is allowed to transition to:</p> <table> <thead> <tr> <th>Value</th> <th>Description</th> </tr> </thead> <tbody> <tr> <td>0h</td> <td>No interface restrictions</td> </tr> <tr> <td>1h</td> <td>Transitions to the PARTIAL state disabled</td> </tr> <tr> <td>2h</td> <td>Transitions to the SLUMBER state disabled</td> </tr> <tr> <td>3h</td> <td>Transitions to both PARTIAL and SLUMBER states disabled</td> </tr> </tbody> </table> <p>All other values reserved</p>	Value	Description	0h	No interface restrictions	1h	Transitions to the PARTIAL state disabled	2h	Transitions to the SLUMBER state disabled	3h	Transitions to both PARTIAL and SLUMBER states disabled
Value	Description										
0h	No interface restrictions										
1h	Transitions to the PARTIAL state disabled										
2h	Transitions to the SLUMBER state disabled										
3h	Transitions to both PARTIAL and SLUMBER states disabled										
7:4	<p>Speed Allowed (SPD) — R/W. Indicates the highest allowable speed of the interface. This speed is limited by the CAP.ISS (ABAR+00h:bit 23:20) field.</p> <table> <thead> <tr> <th>Value</th> <th>Description</th> </tr> </thead> <tbody> <tr> <td>0h</td> <td>No speed negotiation restrictions</td> </tr> <tr> <td>1h</td> <td>Limit speed negotiation to Generation 1 communication rate</td> </tr> </tbody> </table> <p>NOTE: ICH6 Supports only Generation 1 communication rates (1.5 Gb/sec).</p>	Value	Description	0h	No speed negotiation restrictions	1h	Limit speed negotiation to Generation 1 communication rate				
Value	Description										
0h	No speed negotiation restrictions										
1h	Limit speed negotiation to Generation 1 communication rate										
3:0	<p>Device Detection Initialization (DET) — R/W. This field controls the ICH6's device detection and interface initialization.</p> <table> <thead> <tr> <th>Value</th> <th>Description</th> </tr> </thead> <tbody> <tr> <td>0h</td> <td>No device detection or initialization action requested</td> </tr> <tr> <td>1h</td> <td>Perform interface communication initialization sequence to establish communication. This is functionally equivalent to a hard reset and results in the interface being reset and communications re-initialized</td> </tr> <tr> <td>4h</td> <td>Disable the Serial ATA interface and put Phy in offline mode</td> </tr> </tbody> </table> <p>All other values reserved.</p> <p>When this field is written to a 1h, the ICH6 initiates COMRESET and starts the initialization process. When the initialization is complete, this field shall remain 1h until set to another value by software.</p> <p>This field may only be changed to 1h or 4h when PxCMD.ST is 0. Changing this field while the ICH6 is running results in undefined behavior.</p>	Value	Description	0h	No device detection or initialization action requested	1h	Perform interface communication initialization sequence to establish communication. This is functionally equivalent to a hard reset and results in the interface being reset and communications re-initialized	4h	Disable the Serial ATA interface and put Phy in offline mode		
Value	Description										
0h	No device detection or initialization action requested										
1h	Perform interface communication initialization sequence to establish communication. This is functionally equivalent to a hard reset and results in the interface being reset and communications re-initialized										
4h	Disable the Serial ATA interface and put Phy in offline mode										

12.3.2.12 PxSERR—Port [3:0] Serial ATA Error Register (D31:F2)

Address Offset: Port 0: ABAR + 130h Attribute: R/WC
 Port 1: ABAR + 1B0h (Desktop Only)
 Port 2: ABAR + 230h
 Port 3: ABAR + 2B0h (Desktop Only)
 Default Value: 00000000h Size: 32 bits

Bit	Description
	Diagnostics (DIAG) — R/WC. This field contains diagnostic error information for use by diagnostic software in validating correct operation or isolating failure modes:
	Bits Description
31:27	Reserved
26	Exchanged (X) : When set to one this bit indicates a COMINIT signal was received. This bit is reflected in the interrupt register PxlS.PCS.
25	Unrecognized FIS Type (F) : Indicates that one or more FISs were received by the Transport layer with good CRC, but had a type field that was not recognized.
24	Transport state transition error (T) : Indicates that an error has occurred in the transition from one state to another within the Transport layer since the last time this bit was cleared.
23	Link Sequence Error (S) : Indicates that one or more Link state machine error conditions was encountered. The Link Layer state machine defines the conditions under which the link layer detects an erroneous transition.
31:16	22 Handshake Error (H) : Indicates that one or more R_ERR handshake response was received in response to frame transmission. Such errors may be the result of a CRC error detected by the recipient, a disparity or 8b/10b decoding error, or other error condition leading to a negative handshake on a transmitted frame.
	21 CRC Error (C) : Indicates that one or more CRC errors occurred with the Link Layer.
	20 Disparity Error (D) : This field is not used by AHCI.
	19 10b to 8b Decode Error (B) : Indicates that one or more 10b to 8b decoding errors occurred.
	18 Comm Wake (W) : Indicates that a Comm Wake signal was detected by the Phy.
	17 Phy Internal Error (I) : Indicates that the Phy detected some internal error.
	16 PhyRdy Change (N) : When set to 1 this bit indicates that the internal PhyRdy signal changed state since the last time this bit was cleared. In the ICH6, this bit will be set when PhyRdy changes from a 0 -> 1 or a 1 -> 0. The state of this bit is then reflected in the PxlS.PRCS interrupt status bit and an interrupt will be generated if enabled. Software clears this bit by writing a 1 to it.

Bit	Description
15:0	Error (ERR) — R/WC. The ERR field contains error information for use by host software in determining the appropriate response to the error condition. If one or more of bits 11:8 of this register are set, the controller will stop the current transfer.
	Bits Description
	15:12 Reserved
	11 Internal Error (E) : The SATA controller failed due to a master or target abort when attempting to access system memory.
	10 Protocol Error (P) : A violation of the Serial ATA protocol was detected. Note: The ICH6 does not set this bit for all protocol violations that may occur on the SATA link.
	9 Persistent Communication or Data Integrity Error (C) : A communication error that was not recovered occurred that is expected to be persistent. Persistent communications errors may arise from faulty interconnect with the device, from a device that has been removed or has failed, or a number of other causes.
	8 Transient Data Integrity Error (T) : A data integrity error occurred that was not recovered by the interface.
	7:2 Reserved
	1 Recovered Communications Error (M) : Communications between the device and host was temporarily lost but was re-established. This can arise from a device temporarily being removed, from a temporary loss of Phy synchronization, or from other causes and may be derived from the PhyNRdy signal between the Phy and Link layers.
	0 Recovered Data Integrity Error (I) : A data integrity error occurred that was recovered by the interface through a retry operation or other recovery action.

12.3.2.13 PxSACT—Port [3:0] Serial ATA Active (D31:F2)

Address Offset:	Port 0: ABAR + 134h	Attribute:	R/W
	Port 1: ABAR + 1B4h (Desktop Only)		
	Port 2: ABAR + 234h		
	Port 3: ABAR + 2B4h (Desktop Only)		
Default Value:	00000000h	Size:	32 bits

Bit	Description
31:0	Device Status (DS) — R/W. System software sets this bit for SATA queuing operations prior to setting the PxCI.CI bit in the same command slot entry. This field is cleared via the Set Device Bits FIS. This field is also cleared when PxCMD.ST (ABAR+118h/198h/218h/298h:bit 0) is cleared by software, and as a result of a COMRESET or SRST.

12.3.2.14 PxCI—Port [3:0] Command Issue Register (D31:F2)

Address Offset: Port 0: ABAR + 138h Attribute: R/W
 Port 1: ABAR + 1B8h (Desktop Only)
 Port 2: ABAR + 238h
 Port 3: ABAR + 2B8h (Desktop Only)
 Default Value: 00000000h Size: 32 bits

Bit	Description
31:0	<p>Commands Issued (CI) — R/W. This field is set by software to indicate to the ICH6 that a command has been built-in system memory for a command slot and may be sent to the device. When the ICH6 receives a FIS which clears the BSY and DRQ bits for the command, it clears the corresponding bit in this register for that command slot.</p> <p>This field is also cleared when PxCMD.ST (ABAR+118h/198h/218h/298h:bit 0) is cleared by software.</p>

§



13 UHCI Controllers Registers

13.1 PCI Configuration Registers (USB—D29:F0/F1/F2/F3)

Note: Register address locations that are not shown in Table 13-1 and should be treated as Reserved (see Section 6.2 for details).

Table 13-1. UHCI Controller PCI Register Address Map (USB—D29:F0/F1/F2/F3)

Offset	Mnemonic	Register Name	Function 0 Default	Function 1 Default	Function 2 Default	Function 3 Default	Type
00–01h	VID	Vendor Identification	8086h	8086h	8086h	8086h	RO
02–03h	DID	Device Identification	2658h	2659h	265Ah	265Bh	RO
04–05h	PCICMD	PCI Command	0000h	0000h	0000h	0000h	R/W, RO
06–07h	PCISTS	PCI Status	0280h	0280h	0280h	0280h	R/WC, RO
08h	RID	Revision Identification	See register description.	See register description.	See register description.	See register description.	RO
09h	PI	Programming Interface	00h	00h	00h	00h	RO
0Ah	SCC	Sub Class Code	03h	03h	03h	03h	RO
0Bh	BCC	Base Class Code	0Ch	0Ch	0Ch	0Ch	RO
0Dh	MLT	Master Latency Timer	00h	00h	00h	00h	RO
0Eh	HEADTYP	Header Type	80h	00h	00h	00h	RO
20–23h	BASE	Base Address	00000001h	00000001h	00000001h	00000001h	R/W, RO
2C–2Dh	SVID	Subsystem Vendor Identification	0000h	0000h	0000h	0000h	R/WO
2E–2Fh	SID	Subsystem Identification	0000h	0000h	0000h	0000h	R/WO
3Ch	INT_LN	Interrupt Line	00h	00h	00h	00h	R/W
3Dh	INT_PN	Interrupt Pin	See register description.	See register description.	See register description.	See register description.	RO
60h	USB_RELNUM	Serial Bus Release Number	10h	10h	10h	10h	RO
C0–C1h	USB_LEGKEY	USB Legacy Keyboard/ Mouse Control	2000h	2000h	2000h	2000h	R/W, RO R/WC
C4h	USB_RES	USB Resume Enable	00h	00h	00h	00h	R/W
C8h	CWP	Core Well Policy	00h	00h	00h	00h	R/W

NOTE: Refer to the *Intel® I/O Controller Hub 6 (ICH6) Family Specification Update* for the value of the Revision ID Register

13.1.1 VID—Vendor Identification Register (USB—D29:F0/F1/F2/F3)

Address Offset: 00–01h Attribute: RO
 Default Value: 8086h Size: 16 bits

Bit	Description
15:0	Vendor ID — RO. This is a 16-bit value assigned to Intel

13.1.2 DID—Device Identification Register (USB—D29:F0/F1/F2/F3)

Address Offset: 02–03h Attribute: RO
 Default Value: UHCI #1 = 2658h Size: 16 bits
 UHCI #2 = 2659h
 UHCI #3 = 265Ah
 UHCI #4 = 265Bh

Bit	Description
15:0	Device ID — RO. This is a 16-bit value assigned to the ICH6 USB host controllers

13.1.3 PCICMD—PCI Command Register (USB—D29:F0/F1/F2/F3)

Address Offset: 04–05h Attribute: R/W, RO
 Default Value: 0000h Size: 16 bits

Bit	Description
15:11	Reserved
10	Interrupt Disable — R/W. 0 = Enable. The function is able to generate its interrupt to the interrupt controller. 1 = Disable. The function is not capable of generating interrupts. NOTE: The corresponding Interrupt Status bit is not affected by the interrupt enable.
9	Fast Back to Back Enable (FBE) — RO. Hardwired to 0.
8	SERR# Enable — RO. Reserved as 0.
7	Wait Cycle Control (WCC) — RO. Hardwired to 0.
6	Parity Error Response (PER) — RO. Hardwired to 0.
5	VGA Palette Snoop (VPS) — RO. Hardwired to 0.
4	Postable Memory Write Enable (PMWE) — RO. Hardwired to 0.
3	Special Cycle Enable (SCE) — RO. Hardwired to 0.
2	Bus Master Enable (BME) — R/W. 0 = Disable 1 = Enable. ICH6 can act as a master on the PCI bus for USB transfers.
1	Memory Space Enable (MSE) — RO. Hardwired to 0.
0	I/O Space Enable (IOSE) — R/W. This bit controls access to the I/O space registers. 0 = Disable 1 = Enable accesses to the USB I/O registers. The Base Address register for USB should be programmed before this bit is set.

13.1.4 PCISTS—PCI Status Register (USB—D29:F0/F1/F2/F3)

Address Offset: 06–07h Attribute: R/WC, RO
 Default Value: 0280h Size: 16 bits

Note: For the writable bits, software must write a 1 to clear bits that are set. Writing a 0 to the bit has no effect.

Bit	Description
15	Detected Parity Error (DPE) — R/WC. 0 = No parity error detected. 1 = Set when a data parity error data parity error is detected on writes to the UHCI register space or on read completions returned to the host controller.
14	Reserved as 0b. Read Only.
13	Received Master Abort (RMA) — R/WC. 0 = No master abort generated by USB. 1 = USB, as a master, generated a master abort.
12	Reserved. Always read as 0.
11	Signaled Target Abort (STA) — R/WC. 0 = ICH6 did Not terminate transaction for USB function with a target abort. 1 = USB function is targeted with a transaction that the ICH6 terminates with a target abort.
10:9	DEVSEL# Timing Status (DEV_STS) — RO. This 2-bit field defines the timing for DEVSEL# assertion. These read only bits indicate the ICH6's DEVSEL# timing when performing a positive decode. ICH6 generates DEVSEL# with medium timing for USB.
8	Data Parity Error Detected (DPED) — RO. Hardwired to 0.
7	Fast Back to Back Capable (FB2BC) — RO. Hardwired to 1.
6	User Definable Features (UDF) — RO. Hardwired to 0.
5	66 MHz Capable — RO. Hardwired to 0.
4	Capabilities List — RO. Hardwired to 0.
3	Interrupt Status — RO. This bit reflects the state of this function's interrupt at the input of the enable/disable logic. 0 = Interrupt is de-asserted. 1 = Interrupt is asserted. The value reported in this bit is independent of the value in the Interrupt Enable bit.
2:0	Reserved

13.1.5 RID—Revision Identification Register (USB—D29:F0/F1/F2/F3)

Offset Address: 08h Attribute: RO
 Default Value: See bit description Size: 8 bits

Bit	Description
7:0	Revision ID — RO. Refer to the <i>Intel® I/O Controller Hub 6 (ICH6) Family Specification Update</i> for the value of the Revision ID Register

13.1.6 PI—Programming Interface Register (USB—D29:F0/F1/F2/F3)

Address Offset: 09h Attribute: RO
 Default Value: 00h Size: 8 bits

Bit	Description
7:0	Programming Interface — RO. 00h = No specific register level programming interface defined.

13.1.7 SCC—Sub Class Code Register (USB—D29:F0/F1/F2/F3)

Address Offset: 0Ah Attribute: RO
 Default Value: 03h Size: 8 bits

Bit	Description
7:0	Sub Class Code (SCC) — RO. 03h = USB host controller.

13.1.8 BCC—Base Class Code Register (USB—D29:F0/F1/F2/F3)

Address Offset: 0Bh Attribute: RO
 Default Value: 0Ch Size: 8 bits

Bit	Description
7:0	Base Class Code (BCC) — RO. 0Ch = Serial Bus controller.

13.1.9 MLT—Master Latency Timer Register (USB—D29:F0/F1/F2/F3)

Address Offset: 0Dh Attribute: RO
 Default Value: 00h Size: 8 bits

Bit	Description
7:0	Master Latency Timer (MLT) — RO. The USB controller is implemented internal to the ICH6 and not arbitrated as a PCI device. Therefore the device does not require a Master Latency Timer.

13.1.10 HEADTYP—Header Type Register (USB—D29:F0/F1/F2/F3)

Address Offset: 0Eh Attribute: RO
 Default Value: FN 0: 80h Size: 8 bits
 FN 1: 00h
 FN 2: 00h
 FN 3: 00h

For functions 1, 2, and 3, this register is hardwired to 00h. For function 0, bit 7 is determined by the values in the USB Function Disable bits (11:8 of the Function Disable register Chipset Configuration Registers:Offset 3418h).

Bit	Description																														
7	<p>Multi-Function Device — RO. 0 = Single-function device. 1 = Multi-function device.</p> <p>Since the upper functions in this device can be individually hidden, this bit is based on the function-disable bits in Chipset Configuration Space:Offset 3418h as follows:</p> <table border="1"> <thead> <tr> <th>D29:F7_Disable (bit 15)</th> <th>D29:F3_Disable (bit 11)</th> <th>D29:F2_Disable (bit10)</th> <th>D29:F1_Disable (bit 9)</th> <th>Multi-Function Device (this bit)</th> </tr> </thead> <tbody> <tr> <td>0b</td> <td>X</td> <td>X</td> <td>X</td> <td>1</td> </tr> <tr> <td>X</td> <td>0b</td> <td>X</td> <td>X</td> <td>1</td> </tr> <tr> <td>X</td> <td>X</td> <td>0b</td> <td>X</td> <td>1</td> </tr> <tr> <td>X</td> <td>X</td> <td>X</td> <td>0b</td> <td>1</td> </tr> <tr> <td>1</td> <td>1</td> <td>1</td> <td>1</td> <td>0</td> </tr> </tbody> </table>	D29:F7_Disable (bit 15)	D29:F3_Disable (bit 11)	D29:F2_Disable (bit10)	D29:F1_Disable (bit 9)	Multi-Function Device (this bit)	0b	X	X	X	1	X	0b	X	X	1	X	X	0b	X	1	X	X	X	0b	1	1	1	1	1	0
D29:F7_Disable (bit 15)	D29:F3_Disable (bit 11)	D29:F2_Disable (bit10)	D29:F1_Disable (bit 9)	Multi-Function Device (this bit)																											
0b	X	X	X	1																											
X	0b	X	X	1																											
X	X	0b	X	1																											
X	X	X	0b	1																											
1	1	1	1	0																											
6:0	Configuration Layout. Hardwired to 00h, which indicates the standard PCI configuration layout.																														

13.1.11 BASE—Base Address Register (USB—D29:F0/F1/F2/F3)

Address Offset: 20–23h Attribute: R/W, RO
 Default Value: 00000001h Size: 32 bits

Bit	Description
31:16	Reserved
15:5	Base Address — R/W. Bits [15:5] correspond to I/O address signals AD [15:5], respectively. This gives 32 bytes of relocatable I/O space.
4:1	Reserved
0	Resource Type Indicator (RTE) — RO. Hardwired to 1 to indicate that the base address field in this register maps to I/O space.

13.1.12 SVID — Subsystem Vendor Identification Register (USB—D29:F0/F1/F2/F3)

Address Offset: 2Ch–2Dh Attribute: R/WO
 Default Value: 0000h Size: 16 bits
 Lockable: No Power Well: Core

Bit	Description
15:0	Subsystem Vendor ID (SVID) — R/WO. BIOS sets the value in this register to identify the Subsystem Vendor ID. The USB_SVID register, in combination with the USB Subsystem ID register, enables the operating system to distinguish each subsystem from the others. NOTE: The software can write to this register only once per core well reset. Writes should be done as a single, 16-bit cycle.

13.1.13 SID — Subsystem Identification Register (USB—D29:F0/F1/F2/F3)

Address Offset: 2Eh–2Fh Attribute: R/WO
 Default Value: 0000h Size: 16 bits
 Lockable: No Power Well: Core

Bit	Description
15:0	Subsystem ID (SID) — R/WO. BIOS sets the value in this register to identify the Subsystem ID. The SID register, in combination with the SVID register (D29:F0/F1/F2/F3:2C), enables the operating system to distinguish each subsystem from other(s). The value read in this register is the same as what was written to the IDE_SID register. NOTE: The software can write to this register only once per core well reset. Writes should be done as a single, 16-bit cycle.

13.1.14 INT_LN—Interrupt Line Register (USB—D29:F0/F1/F2/F3)

Address Offset: 3Ch Attribute: R/W
 Default Value: 00h Size: 8 bits

Bit	Description
7:0	Interrupt Line (INT_LN) — RO. This data is not used by the ICH6. It is to communicate to software the interrupt line that the interrupt pin is connected to.

13.1.15 INT_PN—Interrupt Pin Register (USB—D29:F0/F1/F2/F3)

Address Offset: 3Dh Attribute: RO
 Default Value: Function 0: See Description Size: 8 bits
 Function 1: See Description
 Function 2: See Description
 Function 3: See Description

Bit	Description								
7:0	<p>Interrupt Line (INT_LN) — RO. This value tells the software which interrupt pin each USB host controller uses. The upper 4 bits are hardwired to 0000b; the lower 4 bits are determine by the Interrupt Pin default values that are programmed in the memory-mapped configuration space as follows:</p> <table border="0"> <tr> <td>Function 0</td> <td>D29IP.U0P (Chipset Configuration Registers:Offset 3108:bits 3:0)</td> </tr> <tr> <td>Function 1</td> <td>D29IP.U1P (Chipset Configuration Registers:Offset 3108:bits 7:4)</td> </tr> <tr> <td>Function 2</td> <td>D29IP.U2P (Chipset Configuration Registers:Offset 3108:bits 11:8)</td> </tr> <tr> <td>Function 3</td> <td>D29IP.U3P (Chipset Configuration Registers:Offset 3108:bits 15:12)</td> </tr> </table> <p>NOTE: This does not determine the mapping to the PIRQ pins.</p>	Function 0	D29IP.U0P (Chipset Configuration Registers:Offset 3108:bits 3:0)	Function 1	D29IP.U1P (Chipset Configuration Registers:Offset 3108:bits 7:4)	Function 2	D29IP.U2P (Chipset Configuration Registers:Offset 3108:bits 11:8)	Function 3	D29IP.U3P (Chipset Configuration Registers:Offset 3108:bits 15:12)
Function 0	D29IP.U0P (Chipset Configuration Registers:Offset 3108:bits 3:0)								
Function 1	D29IP.U1P (Chipset Configuration Registers:Offset 3108:bits 7:4)								
Function 2	D29IP.U2P (Chipset Configuration Registers:Offset 3108:bits 11:8)								
Function 3	D29IP.U3P (Chipset Configuration Registers:Offset 3108:bits 15:12)								

13.1.16 USB_RELNUM—Serial Bus Release Number Register (USB—D29:F0/F1/F2/F3)

Address Offset: 60h Attribute: RO
 Default Value: 10h Size: 8 bits

Bit	Description
7:0	<p>Serial Bus Release Number — RO. 10h = USB controller is compliant with the <i>USB Specification</i>, Release 1.0.</p>

13.1.17 USB_LEGKEY—USB Legacy Keyboard/Mouse Control Register (USB—D29:F0/F1/F2/F3)

Address Offset: C0–C1h Attribute: R/W, R/WC, RO
 Default Value: 2000h Size: 16 bits

This register is implemented separately in each of the USB UHCI functions. However, the enable and status bits for the trapping logic are OR'd and shared, respectively, since their functionality is not specific to any one host controller.

Bit	Description
15	SMI Caused by End of Pass-Through (SMIBYENDPS) — R/WC. This bit indicates if the event occurred. Note that even if the corresponding enable bit is not set in bit 7, then this bit will still be active. It is up to the SMM code to use the enable bit to determine the exact cause of the SMI#. 0 = Software clears this bit by writing a 1 to the bit location in any of the controllers. 1 = Event Occurred
14	Reserved
13	PCI Interrupt Enable (USBPIRQEN) — R/W. This bit is used to prevent the USB controller from generating an interrupt due to transactions on its ports. Note that, when disabled, it will probably be configured to generate an SMI using bit 4 of this register. Default to 1 for compatibility with older USB software. 0 = Disable 1 = Enable
12	SMI Caused by USB Interrupt (SMIBYUSB) — RO. This bit indicates if an interrupt event occurred from this controller. The interrupt from the controller is taken before the enable in bit 13 has any effect to create this read-only bit. Note that even if the corresponding enable bit is not set in Bit 4, this bit may still be active. It is up to the SMM code to use the enable bit to determine the exact cause of the SMI#. 0 = Software should clear the interrupts via the USB controllers. Writing a 1 to this bit will have no effect. 1 = Event Occurred.
11	SMI Caused by Port 64 Write (TRAPBY64W) — R/WC. This bit indicates if the event occurred. Note that even if the corresponding enable bit is not set in bit 3, this bit will still be active. It is up to the SMM code to use the enable bit to determine the exact cause of the SMI#. Note that the A20Gate Pass-Through Logic allows specific port 64h writes to complete without setting this bit. 0 = Software clears this bit by writing a 1 to the bit location in any of the controllers. 1 = Event Occurred.
10	SMI Caused by Port 64 Read (TRAPBY64R) — R/WC. This bit indicates if the event occurred. Note that even if the corresponding enable bit is not set in bit 2, this bit will still be active. It is up to the SMM code to use the enable bit to determine the exact cause of the SMI#. 0 = Software clears this bit by writing a 1 to the bit location in any of the controllers. 1 = Event Occurred.
9	SMI Caused by Port 60 Write (TRAPBY60W) — R/WC. This bit indicates if the event occurred. Note that even if the corresponding enable bit is not set in bit 1, this bit will still be active. It is up to the SMM code to use the enable bit to determine the exact cause of the SMI#. Note that the A20Gate Pass-Through Logic allows this bit. 0 = Software clears this bit by writing a 1 to the bit location in any of the controllers. 1 = Event Occurred.
8	SMI Caused by Port 60 Read (TRAPBY60R) — R/WC. This bit indicates if the event occurred. Note that even if the corresponding enable bit is not set in the bit 0, then this bit will still be active. It is up to the SMM code to use the enable bit to determine the exact cause of the SMI#. 0 = Software clears this bit by writing a 1 to the bit location in any of the controllers. 1 = Event Occurred.

Bit	Description
7	SMI at End of Pass-Through Enable (SMIATENDPS) — R/W. This bit enables SMI at the end of a pass-through. This can occur if an SMI is generated in the middle of a pass-through, and needs to be serviced later. 0 = Disable 1 = Enable
6	Pass Through State (PSTATE) — RO. 0 = If software needs to reset this bit, it should set bit 5 in all of the host controllers to 0. 1 = Indicates that the state machine is in the middle of an A20GATE pass-through sequence.
5	A20Gate Pass-Through Enable (A20PASSEN) — R/W. 0 = Disable. 1 = Enable. Allows A20GATE sequence Pass-Through function. A specific cycle sequence involving writes to port 60h and 64h does not result in the setting of the SMI status bits.
4	SMI on USB IRQ Enable (USBSMIEN) — R/W. 0 = Disable 1 = Enable. USB interrupt will cause an SMI event.
3	SMI on Port 64 Writes Enable (64WEN) — R/W. 0 = Disable 1 = Enable. A 1 in bit 11 will cause an SMI event.
2	SMI on Port 64 Reads Enable (64REN) — R/W. 0 = Disable 1 = Enable. A 1 in bit 10 will cause an SMI event.
1	SMI on Port 60 Writes Enable (60WEN) — R/W. 0 = Disable 1 = Enable. A 1 in bit 9 will cause an SMI event.
0	SMI on Port 60 Reads Enable (60REN) — R/W. 0 = Disable 1 = Enable. A 1 in bit 8 will cause an SMI event.

13.1.18 USB_RES—USB Resume Enable Register (USB—D29:F0/F1/F2/F3)

Address Offset: C4h Attribute: R/W
Default Value: 00h Size: 8 bits

Bit	Description
7:2	Reserved
1	PORT1EN — R/W. Enable port 1 of the USB controller to respond to wakeup events. 0 = The USB controller will not look at this port for a wakeup event. 1 = The USB controller will monitor this port for remote wakeup and connect/disconnect events.
0	PORT0EN — R/W. Enable port 0 of the USB controller to respond to wakeup events. 0 = The USB controller will not look at this port for a wakeup event. 1 = The USB controller will monitor this port for remote wakeup and connect/disconnect events.

13.1.19 CWP—Core Well Policy Register (USB—D29:F0/F1/F2/F3)

Address Offset: C8h Attribute: R/W
 Default Value: 00h Size: 8 bits

Bit	Description
7:1	Reserved
0	Static Bus Master Status Policy Enable (SBMSPE) — R/W. 0 = The UHCI host controller dynamically sets the Bus Master status bit (Power Management 1 Status Register, [PMBASE+00h], bit 4) based on the memory accesses that are scheduled. The default setting provides a more accurate indication of snoopable memory accesses in order to help with software-invoked entry to C3 and C4 power states 1 = The UHCI host controller statically forces the Bus Master Status bit in power management space to 1 whenever the HCHalted bit (USB Status Register, Base+02h, bit 5) is cleared. NOTE: The PCI Power Management registers are enabled in the PCI Device 31: Function 0 space (PM_IO_EN), and can be moved to any I/O location (128-byte aligned).

13.2 USB I/O Registers

Some of the read/write register bits that deal with changing the state of the USB hub ports function such that on read back they reflect the current state of the port, and not necessarily the state of the last write to the register. This allows the software to poll the state of the port and wait until it is in the proper state before proceeding. A host controller reset, global reset, or port reset will immediately terminate a transfer on the affected ports and disable the port. This affects the USBCMD register, bit 4 and the PORTSC registers, bits [12,6,2]. See individual bit descriptions for more detail.

Table 13-2. USB I/O Registers

BASE + Offset	Mnemonic	Register Name	Default	Type
00–01h	USBCMD	USB Command	0000h	R/W
02–03h	USBSTS	USB Status	0020h	R/WC
04–05h	USBINTR	USB Interrupt Enable	0000h	R/W
06–07h	FRNUM	Frame Number	0000h	R/W (see Note 1)
08–0Bh	FRBASEADD	Frame List Base Address	Undefined	R/W
0Ch	SOFMOD	Start of Frame Modify	40h	R/W
0D–0Fh	—	Reserved	—	—
10–11h	PORTSC0	Port 0 Status/Control	0080h	R/WC, RO, R/W (see Note 1)
12–13h	PORTSC1	Port 1 Status/Control	0080h	R/WC, RO, R/W (see Note 1)

NOTES:

1. These registers are WORD writable only. Byte writes to these registers have unpredictable effects.

13.2.1 USBCMD—USB Command Register

I/O Offset: Base + (00–01h) Attribute: R/W
 Default Value: 0000h Size: 16 bits

The Command Register indicates the command to be executed by the serial bus host controller. Writing to the register causes a command to be executed. The table following the bit description provides additional information on the operation of the Run/Stop and Debug bits.

Bit	Description
15:7	Reserved
8	<p>Loop Back Test Mode — R/W.</p> <p>0 = Disable loop back test mode. 1 = ICH6 is in loop back test mode. When both ports are connected together, a write to one port will be seen on the other port and the data will be stored in I/O offset 18h.</p>
7	<p>Max Packet (MAXP) — R/W. This bit selects the maximum packet size that can be used for full speed bandwidth reclamation at the end of a frame. This value is used by the host controller to determine whether it should initiate another transaction based on the time remaining in the SOF counter. Use of reclamation packets larger than the programmed size will cause a Babble error if executed during the critical window at frame end. The Babble error results in the offending endpoint being stalled. Software is responsible for ensuring that any packet which could be executed under bandwidth reclamation be within this size limit.</p> <p>0 = 32 bytes 1 = 64 bytes</p>
6	<p>Configure Flag (CF) — R/W. This bit has no effect on the hardware. It is provided only as a semaphore service for software.</p> <p>0 = Indicates that software has not completed host controller configuration. 1 = HCD software sets this bit as the last action in its process of configuring the host controller.</p>
5	<p>Software Debug (SWDBG) — R/W. The SWDBG bit must only be manipulated when the controller is in the stopped state. This can be determined by checking the HCHalted bit in the USBSTS register.</p> <p>0 = Normal Mode. 1 = Debug mode. In SW Debug mode, the host controller clears the Run/Stop bit after the completion of each USB transaction. The next transaction is executed when software sets the Run/Stop bit back to 1.</p>
4	<p>Force Global Resume (FGR) — R/W.</p> <p>0 = Software resets this bit to 0 after 20 ms has elapsed to stop sending the Global Resume signal. At that time all USB devices should be ready for bus activity. The 1 to 0 transition causes the port to send a low speed EOP signal. This bit will remain a 1 until the EOP has completed. 1 = Host controller sends the Global Resume signal on the USB, and sets this bit to 1 when a resume event (connect, disconnect, or K-state) is detected while in global suspend mode.</p>
3	<p>Enter Global Suspend Mode (EGSM) — R/W.</p> <p>0 = Software resets this bit to 0 to come out of Global Suspend mode. Software writes this bit to 0 at the same time that Force Global Resume (bit 4) is written to 0 or after writing bit 4 to 0. 1 = Host controller enters the Global Suspend mode. No USB transactions occur during this time. The Host controller is able to receive resume signals from USB and interrupt the system. Software must ensure that the Run/Stop bit (bit 0) is cleared prior to setting this bit.</p>

Bit	Description
2	<p>Global Reset (GRESET) — R/W.</p> <p>0 = This bit is reset by the software after a minimum of 10 ms has elapsed as specified in Chapter 7 of the USB Specification.</p> <p>1 = Global Reset. The host controller sends the global reset signal on the USB and then resets all its logic, including the internal hub registers. The hub registers are reset to their power on state. Chip Hardware Reset has the same effect as Global Reset (bit 2), except that the host controller does not send the Global Reset on USB.</p>
1	<p>Host Controller Reset (HCRESET) — R/W. The effects of HCRESET on Hub registers are slightly different from Chip Hardware Reset and Global USB Reset. The HCRESET affects bits [8,3:0] of the Port Status and Control Register (PORTSC) of each port. HCRESET resets the state machines of the host controller including the Connect/Disconnect state machine (one for each port). When the Connect/Disconnect state machine is reset, the output that signals connect/disconnect are negated to 0, effectively signaling a disconnect, even if a device is attached to the port. This virtual disconnect causes the port to be disabled. This disconnect and disabling of the port causes bit 1 (connect status change) and bit 3 (port enable/disable change) of the PORTSC (D29:F0/F1/F2/F3:BASE + 10h) to get set. The disconnect also causes bit 8 of PORTSC to reset. About 64 bit times after HCRESET goes to 0, the connect and low-speed detect will take place, and bits 0 and 8 of the PORTSC will change accordingly.</p> <p>0 = Reset by the host controller when the reset process is complete.</p> <p>1 = Reset. When this bit is set, the host controller module resets its internal timers, counters, state machines, etc. to their initial value. Any transaction currently in progress on USB is immediately terminated.</p>
0	<p>Run/Stop (RS) — R/W. When set to 1, the ICH6 proceeds with execution of the schedule. The ICH6 continues execution as long as this bit is set. When this bit is cleared, the ICH6 completes the current transaction on the USB and then halts. The HC Halted bit in the status register indicates when the host controller has finished the transaction and has entered the stopped state. The host controller clears this bit when the following fatal errors occur: consistency check failure, PCI Bus errors.</p> <p>0 = Stop</p> <p>1 = Run</p> <p>NOTE: This bit should only be cleared if there are no active Transaction Descriptors in the executable schedule or software will reset the host controller prior to setting this bit again.</p>

Table 13-3. Run/Stop, Debug Bit Interaction SWDBG (Bit 5), Run/Stop (Bit 0) Operation

SWDBG (Bit 5)	Run/Stop (Bit 0)	Description
0	0	If executing a command, the host controller completes the command and then stops. The 1.0 ms frame counter is reset and command list execution resumes from start of frame using the frame list pointer selected by the current value in the FRNUM register. (While Run/Stop=0, the FRNUM register (D29:F0/F1/F2/F3:BASE + 06h) can be reprogrammed).
0	1	Execution of the command list resumes from Start Of Frame using the frame list pointer selected by the current value in the FRNUM register. The host controller remains running until the Run/Stop bit is cleared (by software or hardware).
1	0	If executing a command, the host controller completes the command and then stops and the 1.0 ms frame counter is frozen at its current value. All status are preserved. The host controller begins execution of the command list from where it left off when the Run/Stop bit is set.
1	1	Execution of the command list resumes from where the previous execution stopped. The Run/Stop bit is set to 0 by the host controller when a TD is being fetched. This causes the host controller to stop again after the execution of the TD (single step). When the host controller has completed execution, the HC Halted bit in the Status Register is set.

When the USB host controller is in Software Debug Mode (USBCMD Register bit 5=1), the single stepping software debug operation is as follows:

To Enter Software Debug Mode:

1. HCD puts host controller in Stop state by setting the Run/Stop bit to 0.
2. HCD puts host controller in Debug Mode by setting the SWDBG bit to 1.
3. HCD sets up the correct command list and Start Of Frame value for starting point in the Frame List Single Step Loop.
4. HCD sets Run/Stop bit to 1.
5. Host controller executes next active TD, sets Run/Stop bit to 0, and stops.
6. HCD reads the USBCMD register to check if the single step execution is completed (HCHalted=1).
7. HCD checks results of TD execution. Go to step 4 to execute next TD or step 8 to end Software Debug mode.
8. HCD ends Software Debug mode by setting SWDBG bit to 0.
9. HCD sets up normal command list and Frame List table.
10. HCD sets Run/Stop bit to 1 to resume normal schedule execution.

In Software Debug mode, when the Run/Stop bit is set, the host controller starts. When a valid TD is found, the Run/Stop bit is reset. When the TD is finished, the HCHalted bit in the USBSTS register (bit 5) is set.

The SW Debug mode skips over inactive TDs and only halts after an active TD has been executed. When the last active TD in a frame has been executed, the host controller waits until the next SOF is sent and then fetches the first TD of the next frame before halting.

This HCHalted bit can also be used outside of Software Debug mode to indicate when the host controller has detected the Run/Stop bit and has completed the current transaction. Outside of the Software Debug mode, setting the Run/Stop bit to 0 always resets the SOF counter so that when the Run/Stop bit is set the host controller starts over again from the frame list location pointed to by the Frame List Index (see FRNUM Register description) rather than continuing where it stopped.

13.2.2 USBSTS—USB Status Register

I/O Offset: Base + (02–03h) Attribute: R/WC
 Default Value: 0020h Size: 16 bits

This register indicates pending interrupts and various states of the host controller. The status resulting from a transaction on the serial bus is not indicated in this register.

Bit	Description
15:6	Reserved
5	<p>HCHalted — R/WC.</p> <p>0 = Software clears this bit by writing a 1 to it. 1 = The host controller has stopped executing as a result of the Run/Stop bit being set to 0, either by software or by the host controller hardware (debug mode or an internal error). Default.</p>
4	<p>Host Controller Process Error — R/WC.</p> <p>0 = Software clears this bit by writing a 1 to it. 1 = The host controller has detected a fatal error. This indicates that the host controller suffered a consistency check failure while processing a Transfer Descriptor. An example of a consistency check failure would be finding an illegal PID field while processing the packet header portion of the TD. When this error occurs, the host controller clears the Run/Stop bit in the Command register (D29:F0/F1/F2/F3:BASE + 00h, bit 0) to prevent further schedule execution. A hardware interrupt is generated to the system.</p>
3	<p>Host System Error — R/WC.</p> <p>0 = Software clears this bit by writing a 1 to it. 1 = A serious error occurred during a host system access involving the host controller module. In a PCI system, conditions that set this bit to 1 include PCI Parity error, PCI Master Abort, and PCI Target Abort. When this error occurs, the host controller clears the Run/Stop bit in the Command register to prevent further execution of the scheduled TDs. A hardware interrupt is generated to the system.</p>
2	<p>Resume Detect (RSM_DET) — R/WC.</p> <p>0 = Software clears this bit by writing a 1 to it. 1 = The host controller received a "RESUME" signal from a USB device. This is only valid if the Host controller is in a global suspend state (Command register, D29:F0/F1/F2/F3:BASE + 00h, bit 3 = 1).</p>
1	<p>USB Error Interrupt — R/WC.</p> <p>0 = Software clears this bit by writing a 1 to it. 1 = Completion of a USB transaction resulted in an error condition (e.g., error counter underflow). If the TD on which the error interrupt occurred also had its IOC bit (D29:F0/F1/F2/F3:BASE + 04h, bit 2) set, both this bit and Bit 0 are set.</p>
0	<p>USB Interrupt (USBINT) — R/WC.</p> <p>0 = Software clears this bit by writing a 1 to it. 1 = The host controller sets this bit when the cause of an interrupt is a completion of a USB transaction whose Transfer Descriptor had its IOC bit set. Also set when a short packet is detected (actual length field in TD is less than maximum length field in TD), and short packet detection is enabled in that TD.</p>

13.2.3 USBINTR—USB Interrupt Enable Register

I/O Offset: Base + (04–05h) Attribute: R/W
 Default Value: 0000h Size: 16 bits

This register enables and disables reporting of the corresponding interrupt to the software. When a bit is set and the corresponding interrupt is active, an interrupt is generated to the host. Fatal errors (host controller processor error, (D29:F0/F1/F2/F3:BASE + 02h, bit 4, USBSTS Register) cannot be disabled by the host controller. Interrupt sources that are disabled in this register still appear in the Status Register to allow the software to poll for events.

Bit	Description
15:5	Reserved
4	Scratchpad (SP) — R/W.
3	Short Packet Interrupt Enable — R/W. 0 = Disabled. 1 = Enabled.
2	Interrupt on Complete Enable (IOC) — R/W. 0 = Disabled. 1 = Enabled.
1	Resume Interrupt Enable — R/W. 0 = Disabled. 1 = Enabled.
0	Timeout/CRC Interrupt Enable — R/W. 0 = Disabled. 1 = Enabled.

13.2.4 FRNUM—Frame Number Register

I/O Offset: Base + (06–07h) Attribute: R/W (Writes must be Word Writes)
 Default Value: 0000h Size: 16 bits

Bits [10:0] of this register contain the current frame number that is included in the frame SOF packet. This register reflects the count value of the internal frame number counter. Bits [9:0] are used to select a particular entry in the Frame List during scheduled execution. This register is updated at the end of each frame time.

This register must be written as a word. Byte writes are not supported. This register cannot be written unless the host controller is in the STOPPED state as indicated by the HCHalted bit (D29:F0/F1/F2/F3:BASE + 02h, bit 5). A write to this register while the Run/Stop bit is set (D29:F0/F1/F2/F3:BASE + 00h, bit 0) is ignored.

Bit	Description
15:11	Reserved
10:0	Frame List Current Index/Frame Number — R/W. This field provides the frame number in the SOF Frame. The value in this register increments at the end of each time frame (approximately every 1 ms). In addition, bits [9:0] are used for the Frame List current index and correspond to memory address signals [11:2].

13.2.5 FRBASEADD—Frame List Base Address Register

I/O Offset:	Base + (08–0Bh)	Attribute:	R/W
Default Value:	Undefined	Size:	32 bits

This 32-bit register contains the beginning address of the Frame List in the system memory. HCD loads this register prior to starting the schedule execution by the host controller. When written, only the upper 20 bits are used. The lower 12 bits are written as 0's (4-KB alignment). The contents of this register are combined with the frame number counter to enable the host controller to step through the Frame List in sequence. The two least significant bits are always 00. This requires DWord-alignment for all list entries. This configuration supports 1024 Frame List entries.

Bit	Description
31:12	Base Address — R/W. These bits correspond to memory address signals [31:12], respectively.
11:0	Reserved

13.2.6 SOFMOD—Start of Frame Modify Register

I/O Offset: Base + (0Ch) Attribute: R/W
 Default Value: 40h Size: 8 bits

This 1-byte register is used to modify the value used in the generation of SOF timing on the USB. Only the 7 least significant bits are used. When a new value is written into these 7 bits, the SOF timing of the next frame will be adjusted. This feature can be used to adjust out any offset from the clock source that generates the clock that drives the SOF counter. This register can also be used to maintain real time synchronization with the rest of the system so that all devices have the same sense of real time. Using this register, the frame length can be adjusted across the full range required by the USB specification. Its initial programmed value is system dependent based on the accuracy of hardware USB clock and is initialized by system BIOS. It may be reprogrammed by USB system software at any time. Its value will take effect from the beginning of the next frame. This register is reset upon a host controller reset or global reset. Software must maintain a copy of its value for reprogramming if necessary.

Bit	Description																				
7	Reserved																				
6:0	<p>SOF Timing Value — R/W. Guidelines for the modification of frame time are contained in Chapter 7 of the USB Specification. The SOF cycle time (number of SOF counter clock periods to generate a SOF frame length) is equal to 11936 + value in this field. The default value is decimal 64 which gives a SOF cycle time of 12000. For a 12 MHz SOF counter clock input, this produces a 1 ms Frame period. The following table indicates what SOF Timing Value to program into this field for a certain frame period.</p> <table border="1"> <thead> <tr> <th>Frame Length (# 12 MHz Clocks) (decimal)</th> <th>SOF Timing Value (this register) (decimal)</th> </tr> </thead> <tbody> <tr><td>11936</td><td>0</td></tr> <tr><td>11937</td><td>1</td></tr> <tr><td>—</td><td>—</td></tr> <tr><td>11999</td><td>63</td></tr> <tr><td>12000</td><td>64</td></tr> <tr><td>12001</td><td>65</td></tr> <tr><td>—</td><td>—</td></tr> <tr><td>12062</td><td>126</td></tr> <tr><td>12063</td><td>127</td></tr> </tbody> </table>	Frame Length (# 12 MHz Clocks) (decimal)	SOF Timing Value (this register) (decimal)	11936	0	11937	1	—	—	11999	63	12000	64	12001	65	—	—	12062	126	12063	127
Frame Length (# 12 MHz Clocks) (decimal)	SOF Timing Value (this register) (decimal)																				
11936	0																				
11937	1																				
—	—																				
11999	63																				
12000	64																				
12001	65																				
—	—																				
12062	126																				
12063	127																				

13.2.7 PORTSC[0,1]—Port Status and Control Register

I/O Offset:	Port 0/2/4/6: Base + (10–11h) Port 1/3/5/7: Base + (12–13h)	Attribute: R/WC, RO, R/W (Word writes only)
Default Value:	0080h	Size: 16 bits

Note: For Function 0, this applies to ICH6 USB ports 0 and 1; for Function 1, this applies to ICH6 USB ports 2 and 3; for Function 2, this applies to ICH6 USB ports 4 and 5; and for Function 3, this applies to ICH6 USB ports 6 and 7.

After a power-up reset, global reset, or host controller reset, the initial conditions of a port are: no device connected, Port disabled, and the bus line status is 00 (single-ended 0).

Port Reset and Enable Sequence

When software wishes to reset a USB device it will assert the Port Reset bit in the Port Status and Control register. The minimum reset signaling time is 10 mS and is enforced by software. To complete the reset sequence, software clears the port reset bit. The Intel UHCI controller must re-detect the port connect after reset signaling is complete before the controller will allow the port enable bit to be set by software. This time is approximately 5.3 uS. Software has several possible options to meet the timing requirement and a partial list is inumerated below:

- Iterate a short wait, setting the port enable bit and reading it back to see if the enable bit is set.
- Poll the connect status bit and wait for the hardware to recognize the connect prior to enabling the port.
- Wait longer than the hardware detect time after clearing the port reset and prior to enabling the port.

Bit	Description								
15:13	Reserved — RO.								
12	<p>Suspend — R/W. This bit should not be written to a 1 if global suspend is active (bit 3=1 in the USBCMD register). Bit 2 and bit 12 of this register define the hub states as follows:</p> <table border="0"> <tr> <td>Bits [12,2]</td> <td>Hub State</td> </tr> <tr> <td>X,0</td> <td>Disable</td> </tr> <tr> <td>0, 1</td> <td>Enable</td> </tr> <tr> <td>1, 1</td> <td>Suspend</td> </tr> </table> <p>When in suspend state, downstream propagation of data is blocked on this port, except for single-ended 0 resets (global reset and port reset). The blocking occurs at the end of the current transaction, if a transaction was in progress when this bit was written to 1. In the suspend state, the port is sensitive to resume detection. Note that the bit status does not change until the port is suspended and that there may be a delay in suspending a port if there is a transaction currently in progress on the USB.</p> <p>1 = Port in suspend state. 0 = Port not in suspend state.</p> <p>NOTE: Normally, if a transaction is in progress when this bit is set, the port will be suspended when the current transaction completes. However, in the case of a specific error condition (out transaction with babble), the ICH6 may issue a start-of-frame, and then suspend the port.</p>	Bits [12,2]	Hub State	X,0	Disable	0, 1	Enable	1, 1	Suspend
Bits [12,2]	Hub State								
X,0	Disable								
0, 1	Enable								
1, 1	Suspend								
11	<p>Overcurrent Indicator — R/WC. Set by hardware.</p> <p>0 = Software clears this bit by writing a 1 to it. 1 = Overcurrent pin has gone from inactive to active on this port.</p>								

Bit	Description
10	Overcurrent Active — RO. This bit is set and cleared by hardware. 0 = Indicates that the overcurrent pin is inactive (high). 1 = Indicates that the overcurrent pin is active (low).
9	Port Reset — R/W. 0 = Port is not in Reset. 1 = Port is in Reset. When set, the port is disabled and sends the USB Reset signaling.
8	Low Speed Device Attached (LS) — RO. 0 = Full speed device is attached. 1 = Low speed device is attached to this port.
7	Reserved — RO. Always read as 1.
6	Resume Detect (RSM_DET) — R/W. Software sets this bit to a 1 to drive resume signaling. The host controller sets this bit to a 1 if a J-to-K transition is detected for at least 32 microseconds while the port is in the Suspend state. The ICH6 will then reflect the K-state back onto the bus as long as the bit remains a 1, and the port is still in the suspend state (bit 12,2 are '11'). Writing a 0 (from 1) causes the port to send a low speed EOP. This bit will remain a 1 until the EOP has completed. 0 = No resume (K-state) detected/driven on port. 1 = Resume detected/driven on port.
5:4	Line Status — RO. These bits reflect the D+ (bit 4) and D- (bit 5) signals lines' logical levels. These bits are used for fault detect and recovery as well as for USB diagnostics. This field is updated at EOF2 time (See Chapter 11 of the USB Specification).
3	Port Enable/Disable Change — R/WC. For the root hub, this bit gets set only when a port is disabled due to disconnect on that port or due to the appropriate conditions existing at the EOF2 point (See Chapter 11 of the USB Specification). 0 = No change. Software clears this bit by writing a 1 to the bit location. 1 = Port enabled/disabled status has changed.
2	Port Enabled/Disabled (PORT_EN) — R/W. Ports can be enabled by host software only. Ports can be disabled by either a fault condition (disconnect event or other fault condition) or by host software. Note that the bit status does not change until the port state actually changes and that there may be a delay in disabling or enabling a port if there is a transaction currently in progress on the USB. 0 = Disable 1 = Enable
1	Connect Status Change — R/WC. This bit indicates that a change has occurred in the port's Current Connect Status (see bit 0). The hub device sets this bit for any changes to the port device connect status, even if system software has not cleared a connect status change. If, for example, the insertion status changes twice before system software has cleared the changed condition, hub hardware will be setting" an already-set bit (i.e., the bit will remain set). However, the hub transfers the change bit only once when the host controller requests a data transfer to the Status Change endpoint. System software is responsible for determining state change history in such a case. 0 = No change. Software clears this bit by writing a 1 to it. 1 = Change in Current Connect Status.
0	Current Connect Status — RO. This value reflects the current state of the port, and may not correspond directly to the event that caused the Connect Status Change bit (Bit 1) to be set. 0 = No device is present. 1 = Device is present on port.

§



14 EHCI Controller Registers (D29:F7)

14.1 USB EHCI Configuration Registers (USB EHCI—D29:F7)

Note: Register address locations that are not shown in Table 14-1 should be treated as Reserved (see Section 6.2 for details).

Note: All configuration registers in this section are in the core well and reset by a core well reset and the D3-to-D0 warm reset, except as noted.

Table 14-1. USB EHCI PCI Register Address Map (USB EHCI—D29:F7) (Sheet 1 of 2)

Offset	Mnemonic	Register Name	Default Value	Type
00–01h	VID	Vendor Identification	8086h	RO
02–03h	DID	Device Identification	265Ch	RO
04–05h	PCICMD	PCI Command	0000h	R/W, RO
06–07h	PCISTS	PCI Status	0290h	R/W, RO
08h	RID	Revision Identification	See register description	RO
09h	PI	Programming Interface	20h	RO
0Ah	SCC	Sub Class Code	03h	RO
0Bh	BCC	Base Class Code	0Ch	RO
0Dh	PMLT	Primary Master Latency Timer	00h	RO
10–13h	MEM_BASE	Memory Base Address	00000000h	R/W, RO
2C–2Dh	SVID	USB EHCI Subsystem Vendor Identification	XXXXh	R/W (special)
2E–2Fh	SID	USB EHCI Subsystem Identification	XXXXh	R/W (special)
34h	CAP_PTR	Capabilities Pointer	50h	RO
3Ch	INT_LN	Interrupt Line	00h	R/W
3Dh	INT_PN	Interrupt Pin	See register description	RO
50h	PWR_CAPID	PCI Power Management Capability ID	01h	RO
51h	NXT_PTR1	Next Item Pointer	58h	R/W (special)
52–53h	PWR_CAP	Power Management Capabilities	C9C2h	R/W (special)
54–55h	PWR_CNTL_STS	Power Management Control/Status	0000h	R/W, R/WC, RO
58h	DEBUG_CAPID	Debug Port Capability ID	0Ah	RO
59h	NXT_PTR2	Next Item Pointer #2	00h	RO

Table 14-1. USB EHCI PCI Register Address Map (USB EHCI—D29:F7) (Sheet 2 of 2)

Offset	Mnemonic	Register Name	Default Value	Type
5A–5Bh	DEBUG_BASE	Debug Port Base Offset	20A0h	RO
60h	USB_RELNUM	USB Release Number	20h	RO
61h	FL_ADJ	Frame Length Adjustment	20h	R/W
62–63h	PWAKE_CAP	Port Wake Capabilities	01FFh	R/W
64–67h	—	Reserved	—	—
68–6Bh	LEG_EXT_CAP	USB EHCI Legacy Support Extended Capability	0000001h	R/W, RO
6C–6Fh	LEG_EXT_CS	USB EHCI Legacy Extended Support Control/Status	0000000h	R/W, R/WC, RO
70–73h	SPECIAL_SMI	Intel Specific USB 2.0 SMI	0000000h	R/W, R/WC
74–7Fh	—	Reserved	—	—
80h	ACCESS_CNTL	Access Control	00h	R/W
FC–FFh	USB2IR	USB2 Initialization Register	00001706h	R/W

14.1.1 VID—Vendor Identification Register (USB EHCI—D29:F7)

Offset Address: 00–01h Attribute: RO
 Default Value: 8086h Size: 16 bits

Bit	Description
15:0	Vendor ID — RO. This is a 16-bit value assigned to Intel.

14.1.2 DID—Device Identification Register (USB EHCI—D29:F7)

Offset Address: 02–03h Attribute: RO
 Default Value: 265Ch Size: 16 bits

Bit	Description
15:0	Device ID — RO. This is a 16-bit value assigned to the Intel® ICH6 USB EHCI controller.

14.1.3 PCICMD—PCI Command Register (USB EHCI—D29:F7)

Address Offset: 04–05h Attribute: R/W, RO
 Default Value: 0000h Size: 16 bits

Bit	Description
15:11	Reserved
10	Interrupt Disable — R/W. 0 = The function is capable of generating interrupts. 1 = The function can not generate its interrupt to the interrupt controller. Note that the corresponding Interrupt Status bit (D29:F7:06h, bit 3) is not affected by the interrupt enable.
9	Fast Back to Back Enable (FBE) — RO. Hardwired to 0.
8	SERR# Enable (SERR_EN) — R/W. 0 = Disables EHC's capability to generate an SERR#. 1 = The Enhanced Host controller (EHC) is capable of generating (internally) SERR# when it receive a completion status other than "successful" for one of its DMA-initiated memory reads on DMI (and subsequently on its internal interface).
7	Wait Cycle Control (WCC) — RO. Hardwired to 0.
6	Parity Error Response (PER) — RO. Hardwired to 0.
5	VGA Palette Snoop (VPS) — RO. Hardwired to 0.
4	Postable Memory Write Enable (PMWE) — RO. Hardwired to 0.
3	Special Cycle Enable (SCE) — RO. Hardwired to 0.
2	Bus Master Enable (BME) — R/W. 0 = Disables this functionality. 1 = Enables the ICH6 to act as a master on the PCI bus for USB transfers.
1	Memory Space Enable (MSE) — R/W. This bit controls access to the USB 2.0 Memory Space registers. 0 = Disables this functionality. 1 = Enables accesses to the USB 2.0 registers. The Base Address register (D29:F7:10h) for USB 2.0 should be programmed before this bit is set.
0	I/O Space Enable (IOSE) — RO. Hardwired to 0.

14.1.4 PCISTS—PCI Status Register (USB EHCI—D29:F7)

Address Offset: 06–07h
Default Value: 0290h

Attribute: R/W, RO
Size: 16 bits

Note: For the writable bits, software must write a 1 to clear bits that are set. Writing a 0 to the bit has no effect.

Bit	Description
15	Detected Parity Error (DPE) — RO. Hardwired to 0.
14	Signaled System Error (SSE) — R/W. 0 = No SERR# signaled by ICH6. 1 = This bit is set by the ICH6 when it signals SERR# (internally). The SER_EN bit (bit 8 of the Command Register) must be 1 for this bit to be set.
13	Received Master Abort (RMA) — R/W. 0 = No master abort received by EHC on a memory access. 1 = This bit is set when EHC, as a master, receives a master abort status on a memory access. This is treated as a Host Error and halts the DMA engines. This event can optionally generate an SERR# by setting the SERR# Enable bit.
12	Received Target Abort (RTA) — R/W. 0 = No target abort received by EHC on memory access. 1 = This bit is set when EHC, as a master, receives a target abort status on a memory access. This is treated as a Host Error and halts the DMA engines. This event can optionally generate an SERR# by setting the SERR# Enable bit (D29:F7:04h, bit 8).
11	Signaled Target Abort (STA) — RO. This bit is used to indicate when the EHCI function responds to a cycle with a target abort. There is no reason for this to happen, so this bit will be hardwired to 0.
10:9	DEVSEL# Timing Status (DEVT_STS) — RO. This 2-bit field defines the timing for DEVSEL# assertion.
8	Master Data Parity Error Detected (DPED) — R/W. 0 = No data parity error detected on USB2.0 read completion packet. 1 = This bit is set by the ICH6 when a data parity error is detected on a USB 2.0 read completion packet on the internal interface to the EHCI host controller and bit 6 of the Command register is set to 1.
7	Fast Back to Back Capable (FB2BC) — RO. Hardwired to 1.
6	User Definable Features (UDF) — RO. Hardwired to 0.
5	66 MHz Capable (66 MHz_CAP) — RO. Hardwired to 0.
4	Capabilities List (CAP_LIST) — RO. Hardwired to 1 indicating that offset 34h contains a valid capabilities pointer.
3	Interrupt Status — RO. This bit reflects the state of this function's interrupt at the input of the enable/disable logic. 0 = This bit will be 0 when the interrupt is de-asserted. 1 = This bit is a 1 when the interrupt is asserted. The value reported in this bit is independent of the value in the Interrupt Enable bit.
2:0	Reserved

14.1.5 RID—Revision Identification Register (USB EHCI—D29:F7)

Offset Address: 08h Attribute: RO
Default Value: See bit description Size: 8 bits

Bit	Description
7:0	Revision ID — RO. Refer to the <i>Intel® I/O Controller Hub 6 (ICH6) Family Specification Update</i> for the value of the Revision ID Register

14.1.6 PI—Programming Interface Register (USB EHCI—D29:F7)

Address Offset: 09h Attribute: RO
Default Value: 20h Size: 8 bits

Bit	Description
7:0	Programming Interface — RO. A value of 20h indicates that this USB 2.0 host controller conforms to the EHCI Specification.

14.1.7 SCC—Sub Class Code Register (USB EHCI—D29:F7)

Address Offset: 0Ah Attribute: RO
Default Value: 03h Size: 8 bits

Bit	Description
7:0	Sub Class Code (SCC) — RO. 03h = Universal serial bus host controller.

14.1.8 BCC—Base Class Code Register (USB EHCI—D29:F7)

Address Offset: 0Bh Attribute: RO
Default Value: 0Ch Size: 8 bits

Bit	Description
7:0	Base Class Code (BCC) — RO. 0Ch = Serial bus controller.

14.1.9 PMLT—Primary Master Latency Timer Register (USB EHCI—D29:F7)

Address Offset: 0Dh Attribute: RO
Default Value: 00h Size: 8 bits

Bit	Description
7:0	Master Latency Timer Count (MLTC) — RO. Hardwired to 00h. Because the EHCI controller is internally implemented with arbitration on an interface (and not PCI), it does not need a master latency timer.

14.1.10 MEM_BASE—Memory Base Address Register (USB EHCI—D29:F7)

Address Offset: 10–13h Attribute: R/W, RO
Default Value: 00000000h Size: 32 bits

Bit	Description
31:10	Base Address — R/W. Bits [31:10] correspond to memory address signals [31:10], respectively. This gives 1-KB of locatable memory space aligned to 1-KB boundaries.
9:4	Reserved
3	Prefetchable — RO. Hardwired to 0 indicating that this range should not be prefetched.
2:1	Type — RO. Hardwired to 00b indicating that this range can be mapped anywhere within 32-bit address space.
0	Resource Type Indicator (RTE) — RO. Hardwired to 0 indicating that the base address field in this register maps to memory space.

14.1.11 SVID—USB EHCI Subsystem Vendor ID Register (USB EHCI—D29:F7)

Address Offset: 2C–2Dh Attribute: R/W (special)
Default Value: XXXXh Size: 16 bits
Reset: None

Bit	Description
15:0	Subsystem Vendor ID (SVID) — R/W (special). This register, in combination with the USB 2.0 Subsystem ID register, enables the operating system to distinguish each subsystem from the others. NOTE: Writes to this register are enabled when the WRT_RDONLY bit (D29:F7:80h, bit 0) is set to 1.

14.1.12 SID—USB EHCI Subsystem ID Register (USB EHCI—D29:F7)

Address Offset: 2E–2Fh Attribute: R/W (special)
 Default Value: XXXXh Size: 16 bits
 Reset: None

Bit	Description
15:0	Subsystem ID (SID) — R/W (special). BIOS sets the value in this register to identify the Subsystem ID. This register, in combination with the Subsystem Vendor ID register, enables the operating system to distinguish each subsystem from other(s). NOTE: Writes to this register are enabled when the WRT_RDONLY bit (D29:F7:80h, bit 0) is set to 1.

14.1.13 CAP_PTR—Capabilities Pointer Register (USB EHCI—D29:F7)

Address Offset: 34h Attribute: RO
 Default Value: 50h Size: 8 bits

Bit	Description
7:0	Capabilities Pointer (CAP_PTR) — RO. This register points to the starting offset of the USB 2.0 capabilities ranges.

14.1.14 INT_LN—Interrupt Line Register (USB EHCI—D29:F7)

Address Offset: 3Ch Attribute: R/W
 Default Value: 00h Size: 8 bits

Bit	Description
7:0	Interrupt Line (INT_LN) — R/W. This data is not used by the Intel® ICH6. It is used as a scratchpad register to communicate to software the interrupt line that the interrupt pin is connected to.

14.1.15 INT_PN—Interrupt Pin Register (USB EHCI—D29:F7)

Address Offset: 3Dh Attribute: RO
 Default Value: See Description Size: 8 bits

Bit	Description
7:0	Interrupt Pin — RO. This reflects the value of D29IP.EIP (Chipset Configuration Registers:Offset 3108:bits 31:28). NOTE: Bits 7:4 are always 0h



14.1.16 PWR_CAPID—PCI Power Management Capability ID Register (USB EHCI—D29:F7)

Address Offset: 50h Attribute: RO
 Default Value: 01h Size: 8 bits

Bit	Description
7:0	Power Management Capability ID — RO. A value of 01h indicates that this is a PCI Power Management capabilities field.

14.1.17 NXT_PTR1—Next Item Pointer #1 Register (USB EHCI—D29:F7)

Address Offset: 51h Attribute: R/W (special)
 Default Value: 58h Size: 8 bits

Bit	Description
7:0	Next Item Pointer 1 Value — R/W (special). This register defaults to 58h, which indicates that the next capability registers begin at configuration offset 58h. This register is writable when the WRT_RDONLY bit (D29:F7:80h, bit 0) is set. This allows BIOS to effectively hide the Debug Port capability registers, if necessary. This register should only be written during system initialization before the plug-and-play software has enabled any master-initiated traffic. Only values of 58h (Debug Port visible) and 00h (Debug Port invisible) are expected to be programmed in this register. NOTE: Register not reset by D3-to-D0 warm reset.

14.1.18 PWR_CAP—Power Management Capabilities Register (USB EHCI—D29:F7)

Address Offset: 52–53h
 Default Value: C9C2h

Attribute: R/W (special)
 Size: 16 bits

Bit	Description
15:11	PME Support (PME_SUP) — R/W (special). This 5-bit field indicates the power states in which the function may assert PME#. The Intel® ICH6 EHC does not support the D1 or D2 states. For all other states, the ICH6 EHC is capable of generating PME#. Software should never need to modify this field.
10	D2 Support (D2_SUP) — R/W (special). 0 = D2 State is not supported 1 = D2 State is supported
9	D1 Support (D1_SUP) — R/W (special). 0 = D1 State is not supported 1 = D1 State is supported
8:6	Auxiliary Current (AUX_CUR) — R/W (special). The ICH6 EHC reports 375 mA maximum suspend well current required when in the D3 _{COLD} state. This value can be written by BIOS when a more accurate value is known.
5	Device Specific Initialization (DSI) — R/W (special). The ICH6 reports 0, indicating that no device-specific initialization is required.
4	Reserved
3	PME Clock (PME_CLK) — R/W (special). The ICH6 reports 0, indicating that no PCI clock is required to generate PME#.
2:0	Version (VER) — R/W (special). The ICH6 reports 010b, indicating that it complies with Revision 1.1 of the PCI Power Management Specification.

NOTES:

1. Normally, this register is read-only to report capabilities to the power management software. To report different power management capabilities, depending on the system in which the ICH6 is used, bits 15:11 and 8:6 in this register are writable when the WRT_RDONLY bit (D29:F7:80h, bit 0) is set. The value written to this register does not affect the hardware other than changing the value returned during a read.
2. Reset: core well, but not D3-to-D0 warm reset.

14.1.19 PWR_CNTL_STS—Power Management Control/Status Register (USB EHCI—D29:F7)

Address Offset: 54–55h Attribute: R/W, R/WC, RO
 Default Value: 0000h Size: 16 bits

Bit	Description
15	<p>PME Status — R/WC.</p> <p>0 = Writing a 1 to this bit will clear it and cause the internal PME to de-assert (if enabled). 1 = This bit is set when the ICH6 EHC would normally assert the PME# signal independent of the state of the PME_En bit.</p> <p>NOTE: This bit must be explicitly cleared by the operating system each time the operating system is loaded.</p>
14:13	Data Scale — RO. Hardwired to 00b indicating it does not support the associated Data register.
12:9	Data Select — RO. Hardwired to 0000b indicating it does not support the associated Data register.
8	<p>PME Enable — R/W.</p> <p>0 = Disable. 1 = Enable. Enables Intel® ICH6 EHC to generate an internal PME signal when PME_Status is 1.</p> <p>NOTE: This bit must be explicitly cleared by the operating system each time it is initially loaded.</p>
7:2	Reserved
1:0	<p>Power State — R/W. This 2-bit field is used both to determine the current power state of EHC function and to set a new power state. The definition of the field values are:</p> <p>00 = D0 state 11 = D3_{HOT} state</p> <p>If software attempts to write a value of 10b or 01b in to this field, the write operation must complete normally; however, the data is discarded and no state change occurs. When in the D3_{HOT} state, the ICH6 must not accept accesses to the EHC memory range; but the configuration space must still be accessible. When not in the D0 state, the generation of the interrupt output is blocked. Specifically, the PIRQH is not asserted by the ICH6 when not in the D0 state.</p> <p>When software changes this value from the D3_{HOT} state to the D0 state, an internal warm (soft) reset is generated, and software must re-initialize the function.</p>

NOTE: Reset (bits 15, 8): suspend well, and not D3-to-D0 warm reset nor core well reset.

14.1.20 DEBUG_CAPID—Debug Port Capability ID Register (USB EHCI—D29:F7)

Address Offset: 58h Attribute: RO
 Default Value: 0Ah Size: 8 bits

Bit	Description
7:0	Debug Port Capability ID — RO. Hardwired to 0Ah indicating that this is the start of a Debug Port Capability structure.

14.1.21 **NXT_PTR2—Next Item Pointer #2 Register (USB EHCI—D29:F7)**

Address Offset: 59h Attribute: RO
 Default Value: 00h Size: 8 bits

Bit	Description
7:0	Next Item Pointer 2 Capability — RO. Hardwired to 00h to indicate there are no more capability structures in this function.

14.1.22 **DEBUG_BASE—Debug Port Base Offset Register (USB EHCI—D29:F7)**

Address Offset: 5Ah–5Bh Attribute: RO
 Default Value: 20A0h Size: 16 bits

Bit	Description
15:13	BAR Number — RO. Hardwired to 001b to indicate the memory BAR begins at offset 10h in the EHCI configuration space.
12:0	Debug Port Offset — RO. Hardwired to 0A0h to indicate that the Debug Port registers begin at offset A0h in the EHCI memory range.

14.1.23 **USB_RELNUM—USB Release Number Register (USB EHCI—D29:F7)**

Address Offset: 60h Attribute: RO
 Default Value: 20h Size: 8 bits

Bit	Description
7:0	USB Release Number — RO. A value of 20h indicates that this controller follows <i>Universal Serial Bus (USB) Specification, Revision 2.0</i> .

14.1.24 FL_ADJ—Frame Length Adjustment Register (USB EHCI—D29:F7)

Address Offset: 61h Attribute: R/W
 Default Value: 20h Size: 8 bits

This feature is used to adjust any offset from the clock source that generates the clock that drives the SOF counter. When a new value is written into these six bits, the length of the frame is adjusted. Its initial programmed value is system dependent based on the accuracy of hardware USB clock and is initialized by system BIOS. This register should only be modified when the HChalted bit (D29:F7:CAPLENGTH + 24h, bit 12) in the USB2.0_STS register is a 1. Changing value of this register while the host controller is operating yields undefined results. It should not be reprogrammed by USB system software unless the default or BIOS programmed values are incorrect, or the system is restoring the register while returning from a suspended state.

These bits in suspend well and not reset by a D3-to-D0 warm rest or a core well reset.

Bit	Description																				
7:6	Reserved — RO. These bits are reserved for future use and should read as 00b.																				
5:0	<p>Frame Length Timing Value — R/W. Each decimal value change to this register corresponds to 16 high-speed bit times. The SOF cycle time (number of SOF counter clock periods to generate a SOF micro-frame length) is equal to 59488 + value in this field. The default value is decimal 32 (20h), which gives a SOF cycle time of 60000.</p> <table border="0" data-bbox="456 978 1406 1310"> <thead> <tr> <th data-bbox="456 978 824 1026">Frame Length (# 480 MHz Clocks) (decimal)</th> <th data-bbox="824 978 1406 1026">Frame Length Timing Value (this register) (decimal)</th> </tr> </thead> <tbody> <tr> <td data-bbox="456 1026 824 1058">59488</td> <td data-bbox="824 1026 1406 1058">0</td> </tr> <tr> <td data-bbox="456 1058 824 1089">59504</td> <td data-bbox="824 1058 1406 1089">1</td> </tr> <tr> <td data-bbox="456 1089 824 1121">59520</td> <td data-bbox="824 1089 1406 1121">2</td> </tr> <tr> <td data-bbox="456 1121 824 1152">—</td> <td data-bbox="824 1121 1406 1152">—</td> </tr> <tr> <td data-bbox="456 1152 824 1184">59984</td> <td data-bbox="824 1152 1406 1184">31</td> </tr> <tr> <td data-bbox="456 1184 824 1215">60000</td> <td data-bbox="824 1184 1406 1215">32</td> </tr> <tr> <td data-bbox="456 1215 824 1247">—</td> <td data-bbox="824 1215 1406 1247">—</td> </tr> <tr> <td data-bbox="456 1247 824 1278">60480</td> <td data-bbox="824 1247 1406 1278">62</td> </tr> <tr> <td data-bbox="456 1278 824 1310">60496</td> <td data-bbox="824 1278 1406 1310">63</td> </tr> </tbody> </table>	Frame Length (# 480 MHz Clocks) (decimal)	Frame Length Timing Value (this register) (decimal)	59488	0	59504	1	59520	2	—	—	59984	31	60000	32	—	—	60480	62	60496	63
Frame Length (# 480 MHz Clocks) (decimal)	Frame Length Timing Value (this register) (decimal)																				
59488	0																				
59504	1																				
59520	2																				
—	—																				
59984	31																				
60000	32																				
—	—																				
60480	62																				
60496	63																				

14.1.25 PWAKE_CAP—Port Wake Capability Register (USB EHCI—D29:F7)

Address Offset: 62–63h Attribute: R/W
 Default Value: 01FFh Size: 16 bits

This register is in the suspend power well. The intended use of this register is to establish a policy about which ports are to be used for wake events. Bit positions 1–8 in the mask correspond to a physical port implemented on the current EHCI controller. A 1 in a bit position indicates that a device connected below the port can be enabled as a wake-up device and the port may be enabled for disconnect/connect or overcurrent events as wake-up events. This is an information-only mask register. The bits in this register **do not** affect the actual operation of the EHCI host controller. The system-specific policy can be established by BIOS initializing this register to a system-specific value. System software uses the information in this register when enabling devices and ports for remote wake-up.

These bits are not reset by a D3-to-D0 warm rest or a core well reset.

Bit	Description
15:9	Reserved — RO.
8:1	Port Wake Up Capability Mask — R/W. Bit positions 1 through 8 correspond to a physical port implemented on this host controller. For example, bit position 1 corresponds to port 1, bit position 2 corresponds to port 2, etc.
0	Port Wake Implemented — R/W. A 1 in this bit indicates that this register is implemented to software.

14.1.26 LEG_EXT_CAP—USB EHCI Legacy Support Extended Capability Register (USB EHCI—D29:F7)

Address Offset: 68–6Bh Attribute: R/W, RO
 Default Value: 00000001h Size: 32 bits
 Power Well: Suspend

NOTE: These bits are not reset by a D3-to-D0 warm rest or a core well reset.

Bit	Description
31:25	Reserved — RO. Hardwired to 00h
24	HC OS Owned Semaphore — R/W. System software sets this bit to request ownership of the EHCI controller. Ownership is obtained when this bit reads as 1 and the HC BIOS Owned Semaphore bit reads as clear.
23:17	Reserved — RO. Hardwired to 00h
16	HC BIOS Owned Semaphore — R/W. The BIOS sets this bit to establish ownership of the EHCI controller. System BIOS will clear this bit in response to a request for ownership of the EHCI controller by system software.
15:8	Next EHCI Capability Pointer — RO. Hardwired to 00h to indicate that there are no EHCI Extended Capability structures in this device.
7:0	Capability ID — RO. Hardwired to 01h to indicate that this EHCI Extended Capability is the Legacy Support Capability.

14.1.27 LEG_EXT_CS—USB EHCI Legacy Support Extended Control / Status Register (USB EHCI—D29:F7)

Address Offset: 6C–6Fh Attribute: R/W, R/WC, RO
 Default Value: 00000000h Size: 32 bits
 Power Well: Suspend

NOTE: These bits are not reset by a D3-to-D0 warm rest or a core well reset.

Bit	Description
31	SMI on BAR — R/WC. Software clears this bit by writing a 1 to it. 0 = Base Address Register (BAR) not written. 1 = This bit is set to 1 when the Base Address Register (BAR) is written.
30	SMI on PCI Command — R/WC. Software clears this bit by writing a 1 to it. 0 = PCI Command (PCICMD) Register Not written. 1 = This bit is set to 1 when the PCI Command (PCICMD) Register is written.
29	SMI on OS Ownership Change — R/WC. Software clears this bit by writing a 1 to it. 0 = No HC OS Owned Semaphore bit change. 1 = This bit is set to 1 when the HC OS Owned Semaphore bit in the LEG_EXT_CAP register (D29:F7:68h, bit 24) transitions from 1 to 0 or 0 to 1.
28:22	Reserved — RO. Hardwired to 00h
21	SMI on Async Advance — RO. This bit is a shadow bit of the Interrupt on Async Advance bit (D29:F7:CAPLENGTH + 24h, bit 5) in the USB2.0_STS register. NOTE: To clear this bit system software must write a 1 to the Interrupt on Async Advance bit in the USB2.0_STS register.
20	SMI on Host System Error — RO. This bit is a shadow bit of Host System Error bit in the USB2.0_STS register (D29:F7:CAPLENGTH + 24h, bit 4). NOTE: To clear this bit system software must write a 1 to the Host System Error bit in the USB2.0_STS register.
19	SMI on Frame List Rollover — RO. This bit is a shadow bit of Frame List Rollover bit (D29:F7:CAPLENGTH + 24h, bit 3) in the USB2.0_STS register. NOTE: To clear this bit system software must write a 1 to the Frame List Rollover bit in the USB2.0_STS register.
18	SMI on Port Change Detect — RO. This bit is a shadow bit of Port Change Detect bit (D29:F7:CAPLENGTH + 24h, bit 2) in the USB2.0_STS register. NOTE: To clear this bit system software must write a 1 to the Port Change Detect bit in the USB2.0_STS register.
17	SMI on USB Error — RO. This bit is a shadow bit of USB Error Interrupt (USBERRINT) bit (D29:F7:CAPLENGTH + 24h, bit 1) in the USB2.0_STS register. NOTE: To clear this bit system software must write a 1 to the USB Error Interrupt bit in the USB2.0_STS register.
16	SMI on USB Complete — RO. This bit is a shadow bit of USB Interrupt (USBINT) bit (D29:F7:CAPLENGTH + 24h, bit 0) in the USB2.0_STS register. NOTE: To clear this bit system software must write a 1 to the USB Interrupt bit in the USB2.0_STS register.
15	SMI on BAR Enable — R/W. 0 = Disable. 1 = Enable. When this bit is 1 and SMI on BAR (D29:F7:6Ch, bit 31) is 1, then the host controller will issue an SMI.
14	SMI on PCI Command Enable — R/W. 0 = Disable. 1 = Enable. When this bit is 1 and SMI on PCI Command (D29:F7:6Ch, bit 30) is 1, then the host controller will issue an SMI.

Bit	Description
13	SMI on OS Ownership Enable — R/W. 0 = Disable. 1 = Enable. When this bit is a 1 AND the OS Ownership Change bit (D29:F7:6Ch, bit 29) is 1, the host controller will issue an SMI.
12:6	Reserved — RO. Hardwired to 00h
5	SMI on Async Advance Enable — R/W. 0 = Disable. 1 = Enable. When this bit is a 1, and the SMI on Async Advance bit (D29:F7:6Ch, bit 21) is a 1, the host controller will issue an SMI immediately.
4	SMI on Host System Error Enable — R/W. 0 = Disable. 1 = Enable. When this bit is a 1, and the SMI on Host System Error (D29:F7:6Ch, bit 20) is a 1, the host controller will issue an SMI.
3	SMI on Frame List Rollover Enable — R/W. 0 = Disable. 1 = Enable. When this bit is a 1, and the SMI on Frame List Rollover bit (D29:F7:6Ch, bit 19) is a 1, the host controller will issue an SMI.
2	SMI on Port Change Enable — R/W. 0 = Disable. 1 = Enable. When this bit is a 1, and the SMI on Port Change Detect bit (D29:F7:6Ch, bit 18) is a 1, the host controller will issue an SMI.
1	SMI on USB Error Enable — R/W. 0 = Disable. 1 = Enable. When this bit is a 1, and the SMI on USB Error bit (D29:F7:6Ch, bit 17) is a 1, the host controller will issue an SMI immediately.
0	SMI on USB Complete Enable — R/W. 0 = Disable. 1 = Enable. When this bit is a 1, and the SMI on USB Complete bit (D29:F7:6Ch, bit 16) is a 1, the host controller will issue an SMI immediately.

14.1.28 SPECIAL_SMI—Intel Specific USB 2.0 SMI Register (USB EHCI—D29:F7)

Address Offset: 70–73h Attribute: R/W, R/WC
 Default Value: 00000000h Size: 32 bits
 Power Well: Suspend

NOTE: These bits are not reset by a D3-to-D0 warm rest or a core well reset.

Bit	Description
31:30	Reserved — RO. Hardwired to 00h
29:22	SMI on PortOwner — R/WC. Software clears these bits by writing a 1 to it. 0 = No Port Owner bit change. 1 = Bits 29:22 correspond to the Port Owner bits for ports 1 (22) through 8 (29). These bits are set to 1 when the associated Port Owner bits transition from 0 to 1 or 1 to 0.
21	SMI on PMCSR — R/WC. Software clears these bits by writing a 1 to it. 0 = Power State bits Not modified. 1 = Software modified the Power State bits in the Power Management Control/Status (PMCSR) register (D29:F7:54h).
20	SMI on Async — R/WC. Software clears these bits by writing a 1 to it. 0 = No Async Schedule Enable bit change 1 = Async Schedule Enable bit transitioned from 1 to 0 or 0 to 1.

Bit	Description
19	SMI on Periodic — R/WC. Software clears this bit by writing a 1 it. 0 = No Periodic Schedule Enable bit change. 1 = Periodic Schedule Enable bit transitions from 1 to 0 or 0 to 1.
18	SMI on CF — R/WC. Software clears this bit by writing a 1 it. 0 = No Configure Flag (CF) change. 1 = Configure Flag (CF) transitions from 1 to 0 or 0 to 1.
17	SMI on HCHalted — R/WC. Software clears this bit by writing a 1 it. 0 = HCHalted did Not transition to 1 (as a result of the Run/Stop bit being cleared). 1 = HCHalted transitions to 1 (as a result of the Run/Stop bit being cleared).
16	SMI on HCRreset — R/WC. Software clears this bit by writing a 1 it. 0 = HCRESET did Not transitioned to 1. 1 = HCRESET transitioned to 1.
15:14	Reserved — RO. Hardwired to 00h
13:6	SMI on PortOwner Enable — R/W. 0 = Disable. 1 = Enable. When any of these bits are 1 and the corresponding SMI on PortOwner bits are 1, then the host controller will issue an SMI. Unused ports should have their corresponding bits cleared.
5	SMI on PMSCR Enable — R/W. 0 = Disable. 1 = Enable. When this bit is 1 and SMI on PMSCR is 1, then the host controller will issue an SMI.
4	SMI on Async Enable — R/W. 0 = Disable. 1 = Enable. When this bit is 1 and SMI on Async is 1, then the host controller will issue an SMI
3	SMI on Periodic Enable — R/W. 0 = Disable. 1 = Enable. When this bit is 1 and SMI on Periodic is 1, then the host controller will issue an SMI.
2	SMI on CF Enable — R/W. 0 = Disable. 1 = Enable. When this bit is 1 and SMI on CF is 1, then the host controller will issue an SMI.
1	SMI on HCHalted Enable — R/W. 0 = Disable. 1 = Enable. When this bit is a 1 and SMI on HCHalted is 1, then the host controller will issue an SMI.
0	SMI on HCRreset Enable — R/W. 0 = Disable. 1 = Enable. When this bit is a 1 and SMI on HCRreset is 1, then host controller will issue an SMI.

14.1.29 ACCESS_CNTL—Access Control Register (USB EHCI—D29:F7)

Address Offset: 80h Attribute: R/W
Default Value: 00h Size: 8 bits

Bit	Description
7:1	Reserved
0	WRT_RDONLY — R/W. When set to 1, this bit enables a select group of normally read-only registers in the EHC function to be written by software. Registers that may only be written when this mode is entered are noted in the summary tables and detailed description as "Read/Write-Special". The registers fall into two categories: 1. System-configured parameters, and 2. Status bits

14.1.30 USB2IR—USB2 Initialization Register (USB EHCI—D29:F7)

Address Offset: FC-FFh Attribute: R/W
Default Value: 00001706h Size: 32 bits

Bit	Description
31:8	Reserved
7	USB EHCI Initialization Field 2 — R/W. Mobile: BIOS must clear this bit to 0b. Desktop: BIOS must set this bit to 1b.
6	Reserved
5	USB EHCI Initialization Field 1 — R/W. BIOS must clear this bit to 0b.
4:0	Reserved

14.2 Memory-Mapped I/O Registers

The EHCI memory-mapped I/O space is composed of two sets of registers: Capability Registers and Operational Registers.

Note: The ICH6 EHCI controller will not accept memory transactions (neither reads nor writes) as a target that are locked transactions. The locked transactions should not be forwarded to PCI as the address space is known to be allocated to USB.

Note: When the EHCI function is in the D3 PCI power state, accesses to the USB 2.0 memory range are ignored and result a master abort. Similarly, if the Memory Space Enable (MSE) bit (D29:F7:04h, bit 1) is not set in the Command register in configuration space, the memory range will not be decoded by the ICH6 enhanced host controller (EHC). If the MSE bit is not set, then the ICH6 must default to allowing any memory accesses for the range specified in the BAR to go to PCI. This is because the range may not be valid and, therefore, the cycle must be made available to any other targets that may be currently using that range.

14.2.1 Host Controller Capability Registers

These registers specify the limits, restrictions and capabilities of the host controller implementation. Within the host controller capability registers, only the structural parameters register is writable. These registers are implemented in the suspend well and is only reset by the standard suspend-well hardware reset, not by HCRESET or the D3-to-D0 reset.

Table 14-2. Enhanced Host Controller Capability Registers

MEM_BASE + Offset	Mnemonic	Register	Default	Type
00h	CAPLENGTH	Capabilities Registers Length	20h	RO
02–03h	HCVERSION	Host Controller Interface Version Number	0100h	RO
04–07h	HCSPARAMS	Host Controller Structural Parameters	00104208h	R/W (special), RO
08–0Bh	HCCPARAMS	Host Controller Capability Parameters	00006871h	RO

NOTE: “Read/Write Special” means that the register is normally read-only, but may be written when the WRT_RDONLY bit is set. Because these registers are expected to be programmed by BIOS during initialization, their contents must not get modified by HCRESET or D3-to-D0 internal reset.

14.2.1.1 CAPLENGTH—Capability Registers Length Register

Offset: MEM_BASE + 00h Attribute: RO
 Default Value: 20h Size: 8 bits

Bit	Description
7:0	Capability Register Length Value — RO. This register is used as an offset to add to the Memory Base Register (D29:F7:10h) to find the beginning of the Operational Register Space. This field is hardwired to 20h indicating that the Operation Registers begin at offset 20h.

14.2.1.2 HCIVERSION—Host Controller Interface Version Number Register

Offset: MEM_BASE + 02–03h Attribute: RO
 Default Value: 0100h Size: 16 bits

Bit	Description
15:0	Host Controller Interface Version Number — RO. This is a two-byte register containing a BCD encoding of the version number of interface that this host controller interface conforms.

14.2.1.3 HCSPARAMS—Host Controller Structural Parameters

Offset: MEM_BASE + 04–07h Attribute: R/W (special), RO
 Default Value: 00104208h Size: 32 bits

Note: This register is reset by a suspend well reset and not a D3-to-D0 reset or HCRESET.

Bit	Description
31:24	Reserved — RO. Default=0h.
23:20	Debug Port Number (DP_N) — RO (special). Hardwired to 1h indicating that the Debug Port is on the lowest numbered port on the ICH6.
19:16	Reserved
15:12	Number of Companion Controllers (N_CC) — R/W (special). This field indicates the number of companion controllers associated with this USB EHCI host controller. A 0 in this field indicates there are no companion host controllers. Port-ownership hand-off is not supported. Only high-speed devices are supported on the host controller root ports. A value of 1 or more in this field indicates there are companion USB UHCI host controller(s). Port-ownership hand-offs are supported. High, Full- and Low-speed devices are supported on the host controller root ports. The ICH6 allows the default value of 4h to be over-written by BIOS. When removing classic controllers, they should be disabled in the following order: Function 3, Function 2, Function 1, and Function 0, which correspond to ports 7:6, 5:4, 3:2, and 1:0, respectively.
11:8	Number of Ports per Companion Controller (N_PCC) — RO. Hardwired to 2h. This field indicates the number of ports supported per companion host controller. It is used to indicate the port routing configuration to system software.
7:4	Reserved. These bits are reserved and default to 0.
3:0	N_PORTS — R/W (special). This field specifies the number of physical downstream ports implemented on this host controller. The value of this field determines how many port registers are addressable in the Operational Register Space. Valid values are in the range of 1h to Fh. The ICH6 reports 8h by default. However, software may write a value less than 8 for some platform configurations. A 0 in this field is undefined.

NOTE: This register is writable when the WRT_RDONLY bit is set.

14.2.1.4 HCCPARAMS—Host Controller Capability Parameters Register

Offset: MEM_BASE + 08–0Bh Attribute: RO
 Default Value: 00006871h Size: 32 bits

Bit	Description
31:16	Reserved
15:8	EHCI Extended Capabilities Pointer (EECP) — RO. This field is hardwired to 68h, indicating that the EHCI capabilities list exists and begins at offset 68h in the PCI configuration space.
7:4	<p>Isochronous Scheduling Threshold — RO. This field indicates, relative to the current position of the executing host controller, where software can reliably update the isochronous schedule. When bit 7 is 0, the value of the least significant 3 bits indicates the number of micro-frames a host controller hold a set of isochronous data structures (one or more) before flushing the state. When bit 7 is a 1, then host software assumes the host controller may cache an isochronous data structure for an entire frame. Refer to the EHCI specification for details on how software uses this information for scheduling isochronous transfers.</p> <p>This field is hardwired to 7h.</p>
3	Reserved. These bits are reserved and should be set to 0.
2	Asynchronous Schedule Park Capability — RO. This bit is hardwired to 0 indicating that the host controller does not support this optional feature
1	<p>Programmable Frame List Flag — RO.</p> <p>0 = System software must use a frame list length of 1024 elements with this host controller. The USB2.0_CMD register (D29:F7:CAPLENGTH + 20h, bits 3:2) <i>Frame List Size</i> field is a read-only register and must be set to 0.</p> <p>1 = System software can specify and use a smaller frame list and configure the host controller via the USB2.0_CMD register <i>Frame List Size</i> field. The frame list must always be aligned on a 4K page boundary. This requirement ensures that the frame list is always physically contiguous.</p>
0	<p>64-bit Addressing Capability — RO. This field documents the addressing range capability of this implementation. The value of this field determines whether software should use the 32-bit or 64-bit data structures. Values for this field have the following interpretation:</p> <p>0 = Data structures using 32-bit address memory pointers 1 = Data structures using 64-bit address memory pointers</p> <p>This bit is hardwired to 1.</p> <p>NOTE: ICH6 only implements 44 bits of addressing. Bits 63:44 will always be 0.</p>

14.2.2 Host Controller Operational Registers

This section defines the enhanced host controller operational registers. These registers are located after the capabilities registers. The operational register base must be DWord-aligned and is calculated by adding the value in the first capabilities register (CAPLENGTH) to the base address of the enhanced host controller register address space (MEM_BASE). Since CAPLENGTH is always 20h, Table 14-3 already accounts for this offset. All registers are 32 bits in length.

Table 14-3. Enhanced Host Controller Operational Register Address Map

MEM_BASE + Offset	Mnemonic	Register Name	Default	Special Notes	Type
20–23h	USB2.0_CMD	USB 2.0 Command	00080000h		R/W, RO
24–27h	USB2.0_STS	USB 2.0 Status	00001000h		R/WC, RO
28–2Bh	USB2.0_INTR	USB 2.0 Interrupt Enable	00000000h		R/W
2C–2Fh	FRINDEX	USB 2.0 Frame Index	00000000h		R/W,
30–33h	CTRLDS-SEGMENT	Control Data Structure Segment	00000000h		R/W, RO
34–37h	PERODI-CLISTBASE	Period Frame List Base Address	00000000h		R/W
38–3Bh	ASYNCLIS-TADDR	Current Asynchronous List Address	00000000h		R/W
3C–5Fh	—	Reserved	0h		RO
60–63h	CONFIGGLAG	Configure Flag	00000000h	Suspend	R/W
64–67h	PORT0SC	Port 0 Status and Control	00003000h	Suspend	R/W, R/WC, RO
68–6Bh	PORT1SC	Port 1 Status and Control	00003000h	Suspend	R/W, R/WC, RO
6C–6Fh	PORT2SC	Port 2 Status and Control	00003000h	Suspend	R/W, R/WC, RO
70–73h	PORT3SC	Port 3 Status and Control	00003000h	Suspend	R/W, R/WC, RO
74–77h	PORT4SC	Port 4 Status and Control	00003000h	Suspend	R/W, R/WC, RO
78–7Bh	PORT5SC	Port 5 Status and Control	00003000h	Suspend	R/W, R/WC, RO
7C–7Fh	PORT6SC	Port 6 Status and Control	00003000h	Suspend	R/W, R/WC, RO
80–83h	PORT7SC	Port 7 Status and Control	00003000h	Suspend	R/W, R/WC, RO
84–9Fh	—	Reserved	Undefined		RO
A0–B3h	—	Debug Port Registers	Undefined		See register description
B4–3FFh	—	Reserved	Undefined		RO

Note: Software must read and write these registers using only DWord accesses. These registers are divided into two sets. The first set at offsets MEM_BASE + 00:3Bh are implemented in the core power well. Unless otherwise noted, the core well registers are reset by the assertion of any of the following:

- Core well hardware reset
- HCRESET
- D3-to-D0 reset

The second set at offsets MEM_BASE + 60h to the end of the implemented register space are implemented in the Suspend power well. Unless otherwise noted, the suspend well registers are reset by the assertion of either of the following:

- Suspend well hardware reset
- HCRESET

14.2.2.1 USB2.0_CMD—USB 2.0 Command Register

Offset: MEM_BASE + 20–23h Attribute: R/W, RO
 Default Value: 00080000h Size: 32 bits

Bit	Description																		
31:24	Reserved. These bits are reserved and should be set to 0 when writing this register.																		
23:16	<p>Interrupt Threshold Control — R/W. System software uses this field to select the maximum rate at which the host controller will issue interrupts. The only valid values are defined below. If software writes an invalid value to this register, the results are undefined.</p> <table> <thead> <tr> <th>Value</th> <th>Maximum Interrupt Interval</th> </tr> </thead> <tbody> <tr> <td>00h</td> <td>Reserved</td> </tr> <tr> <td>01h</td> <td>1 micro-frame</td> </tr> <tr> <td>02h</td> <td>2 micro-frames</td> </tr> <tr> <td>04h</td> <td>4 micro-frames</td> </tr> <tr> <td>08h</td> <td>8 micro-frames (default, equates to 1 ms)</td> </tr> <tr> <td>10h</td> <td>16 micro-frames (2 ms)</td> </tr> <tr> <td>20h</td> <td>32 micro-frames (4 ms)</td> </tr> <tr> <td>40h</td> <td>64 micro-frames (8 ms)</td> </tr> </tbody> </table>	Value	Maximum Interrupt Interval	00h	Reserved	01h	1 micro-frame	02h	2 micro-frames	04h	4 micro-frames	08h	8 micro-frames (default, equates to 1 ms)	10h	16 micro-frames (2 ms)	20h	32 micro-frames (4 ms)	40h	64 micro-frames (8 ms)
Value	Maximum Interrupt Interval																		
00h	Reserved																		
01h	1 micro-frame																		
02h	2 micro-frames																		
04h	4 micro-frames																		
08h	8 micro-frames (default, equates to 1 ms)																		
10h	16 micro-frames (2 ms)																		
20h	32 micro-frames (4 ms)																		
40h	64 micro-frames (8 ms)																		
15:8	Reserved. These bits are reserved and should be set to 0 when writing this register.																		
11:8	Unimplemented Asynchronous Park Mode Bits. Hardwired to 000b indicating the host controller does not support this optional feature.																		
7	Light Host Controller Reset — RO. Hardwired to 0. The ICH6 does not implement this optional reset.																		
6	<p>Interrupt on Async Advance Doorbell — R/W. This bit is used as a doorbell by software to tell the host controller to issue an interrupt the next time it advances asynchronous schedule.</p> <p>0 = The host controller sets this bit to a 0 after it has set the Interrupt on Async Advance status bit (D29:F7:CAPLENGTH + 24h, bit 5) in the USB2.0_STS register to a 1.</p> <p>1 = Software must write a 1 to this bit to ring the doorbell. When the host controller has evicted all appropriate cached schedule state, it sets the Interrupt on Async Advance status bit in the USB2.0_STS register. If the <i>Interrupt on Async Advance Enable</i> bit in the USB2.0_INTR register (D29:F7:CAPLENGTH + 28h, bit 5) is a 1 then the host controller will assert an interrupt at the next interrupt threshold. See the EHCI specification for operational details.</p> <p>NOTE: Software should not write a 1 to this bit when the asynchronous schedule is inactive. Doing so will yield undefined results.</p>																		
5	<p>Asynchronous Schedule Enable — R/W. Default 0b. This bit controls whether the host controller skips processing the Asynchronous Schedule.</p> <p>0 = Do not process the Asynchronous Schedule</p> <p>1 = Use the ASYNCLISTADDR register to access the Asynchronous Schedule.</p>																		
4	<p>Periodic Schedule Enable — R/W. Default 0b. This bit controls whether the host controller skips processing the Periodic Schedule.</p> <p>0 = Do not process the Periodic Schedule</p> <p>1 = Use the PERIODICLISTBASE register to access the Periodic Schedule.</p>																		

Bit	Description															
3:2	<p>Frame List Size — RO. The ICH6 hardwires this field to 00b because it only supports the 1024-element frame list size.</p>															
1	<p>Host Controller Reset (HCRESET) — R/W. This control bit used by software to reset the host controller. The effects of this on root hub registers are similar to a Chip Hardware Reset (i.e., RSMRST# assertion and PWROK de-assertion on the ICH6).</p> <p>When software writes a 1 to this bit, the host controller resets its internal pipelines, timers, counters, state machines, etc. to their initial value. Any transaction currently in progress on USB is immediately terminated. A USB reset is not driven on downstream ports.</p> <p>NOTE: PCI configuration registers and Host controller capability registers are not effected by this reset.</p> <p>All operational registers, including port registers and port state machines are set to their initial values. Port ownership reverts to the companion host controller(s), with the side effects described in the EHCI spec. Software must re-initialize the host controller in order to return the host controller to an operational state.</p> <p>This bit is set to 0 by the host controller when the reset process is complete. Software cannot terminate the reset process early by writing a 0 to this register.</p> <p>Software should not set this bit to a 1 when the HCHalted bit (D29:F7:CAPLENGTH + 24h, bit 12) in the USB2.0_STS register is a 0. Attempting to reset an actively running host controller will result in undefined behavior. This reset me be used to leave EHCI port test modes.</p>															
0	<p>Run/Stop (RS) — R/W.</p> <p>0 = Stop (default) 1 = Run. When set to a 1, the Host controller proceeds with execution of the schedule. The Host controller continues execution as long as this bit is set. When this bit is set to 0, the Host controller completes the current transaction on the USB and then halts. The HCHalted bit in the USB2.0_STS register indicates when the Host controller has finished the transaction and has entered the stopped state.</p> <p>Software should not write a 1 to this field unless the host controller is in the Halted state (i.e., HCHalted in the USBSTS register is a 1). The Halted bit is cleared immediately when the Run bit is set.</p> <p>The following table explains how the different combinations of Run and Halted should be interpreted:</p> <table border="1" style="margin-left: auto; margin-right: auto;"> <thead> <tr> <th>Run/Stop</th> <th>Halted</th> <th>Interpretation</th> </tr> </thead> <tbody> <tr> <td style="text-align: center;">0b</td> <td style="text-align: center;">0b</td> <td>In the process of halting</td> </tr> <tr> <td style="text-align: center;">0b</td> <td style="text-align: center;">1b</td> <td>Halted</td> </tr> <tr> <td style="text-align: center;">1b</td> <td style="text-align: center;">0b</td> <td>Running</td> </tr> <tr> <td style="text-align: center;">1b</td> <td style="text-align: center;">1b</td> <td>Invalid - the HCHalted bit clears immediately</td> </tr> </tbody> </table> <p>Memory read cycles initiated by the EHC that receive any status other than Successful will result in this bit being cleared.</p>	Run/Stop	Halted	Interpretation	0b	0b	In the process of halting	0b	1b	Halted	1b	0b	Running	1b	1b	Invalid - the HCHalted bit clears immediately
Run/Stop	Halted	Interpretation														
0b	0b	In the process of halting														
0b	1b	Halted														
1b	0b	Running														
1b	1b	Invalid - the HCHalted bit clears immediately														

NOTE: The Command Register indicates the command to be executed by the serial bus host controller. Writing to the register causes a command to be executed.

14.2.2.2 USB2.0_STS—USB 2.0 Status Register

Offset: MEM_BASE + 24–27h Attribute: R/WC, RO
 Default Value: 00001000h Size: 32 bits

This register indicates pending interrupts and various states of the Host controller. The status resulting from a transaction on the serial bus is not indicated in this register. See the Interrupts description in section 4 of the EHCI specification for additional information concerning USB 2.0 interrupt conditions.

Note: For the writable bits, software must write a 1 to clear bits that are set. Writing a 0 has no effect.

Bit	Description
31:16	Reserved. These bits are reserved and should be set to 0 when writing this register.
15	<p>Asynchronous Schedule Status — RO. This bit reports the current real status of the Asynchronous Schedule.</p> <p>0 = Status of the Asynchronous Schedule is disabled. (Default) 1 = Status of the Asynchronous Schedule is enabled.</p> <p>NOTE: The Host controller is not required to <i>immediately</i> disable or enable the Asynchronous Schedule when software transitions the <i>Asynchronous Schedule Enable</i> bit (D29:F7:CAPLENGTH + 20h, bit 5) in the USB2.0_CMD register. When this bit and the <i>Asynchronous Schedule Enable</i> bit are the same value, the Asynchronous Schedule is either enabled (1) or disabled (0).</p>
14	<p>Periodic Schedule Status — RO. This bit reports the current real status of the Periodic Schedule.</p> <p>0 = Status of the Periodic Schedule is disabled. (Default) 1 = Status of the Periodic Schedule is enabled.</p> <p>NOTE: The Host controller is not required to <i>immediately</i> disable or enable the Periodic Schedule when software transitions the <i>Periodic Schedule Enable</i> bit (D29:F7:CAPLENGTH + 20h, bit 4) in the USB2.0_CMD register. When this bit and the <i>Periodic Schedule Enable</i> bit are the same value, the Periodic Schedule is either enabled (1) or disabled (0).</p>
13	<p>Reclamation — RO. 0=Default. This read-only status bit is used to detect an empty asynchronous schedule. The operational model and valid transitions for this bit are described in Section 4 of the EHCI Specification.</p>
12	<p>HCHalted — RO.</p> <p>0 = This bit is a 0 when the Run/Stop bit is a 1. 1 = The Host controller sets this bit to 1 after it has stopped executing as a result of the Run/Stop bit being set to 0, either by software or by the Host controller hardware (e.g., internal error). (Default)</p>
11:6	Reserved
5	<p>Interrupt on Async Advance — R/WC. 0=Default. System software can force the host controller to issue an interrupt the next time the host controller advances the asynchronous schedule by writing a 1 to the <i>Interrupt on Async Advance Doorbell</i> bit (D29:F7:CAPLENGTH + 20h, bit 6) in the USB2.0_CMD register. This bit indicates the assertion of that interrupt source.</p>
4	<p>Host System Error — R/WC.</p> <p>0 = No serious error occurred during a host system access involving the Host controller module 1 = The Host controller sets this bit to 1 when a serious error occurs during a host system access involving the Host controller module. A hardware interrupt is generated to the system. Memory read cycles initiated by the EHC that receive any status other than Successful will result in this bit being set.</p> <p>When this error occurs, the Host controller clears the Run/Stop bit in the USB2.0_CMD register (D29:F7:CAPLENGTH + 20h, bit 0) to prevent further execution of the scheduled TDs. A hardware interrupt is generated to the system (if enabled in the Interrupt Enable Register).</p>

Bit	Description
3	<p>Frame List Rollover — R/WC.</p> <p>0 = No <i>Frame List Index</i> rollover from its maximum value to 0. 1 = The Host controller sets this bit to a 1 when the <i>Frame List Index</i> (see Section) rolls over from its maximum value to 0. Since the ICH6 only supports the 1024-entry Frame List Size, the <i>Frame List Index</i> rolls over every time FRNUM13 toggles.</p>
2	<p>Port Change Detect — R/WC. This bit is allowed to be maintained in the Auxiliary power well. Alternatively, it is also acceptable that on a D3 to D0 transition of the EHCI HC device, this bit is loaded with the OR of all of the PORTSC change bits (including: Force port resume, overcurrent change, enable/disable change and connect status change). Regardless of the implementation, when this bit is readable (i.e., in the D0 state), it must provide a valid view of the Port Status registers.</p> <p>0 = No change bit transition from a 0 to 1 or No Force Port Resume bit transition from 0 to 1 as a result of a J-K transition detected on a suspended port. 1 = The Host controller sets this bit to 1 when any port for which the <i>Port Owner</i> bit is set to 0 has a change bit transition from a 0 to 1 or a Force Port Resume bit transition from 0 to 1 as a result of a J-K transition detected on a suspended port.</p>
1	<p>USB Error Interrupt (USBERRINT) — R/WC.</p> <p>0 = No error condition. 1 = The Host controller sets this bit to 1 when completion of a USB transaction results in an error condition (e.g., error counter underflow). If the TD on which the error interrupt occurred also had its IOC bit set, both this bit and Bit 0 are set. See the EHCI specification for a list of the USB errors that will result in this interrupt being asserted.</p>
0	<p>USB Interrupt (USBINT) — R/WC.</p> <p>0 = No completion of a USB transaction whose Transfer Descriptor had its IOC bit set. No short packet is detected. 1 = The Host controller sets this bit to 1 when the cause of an interrupt is a completion of a USB transaction whose Transfer Descriptor had its IOC bit set. The Host controller also sets this bit to 1 when a short packet is detected (actual number of bytes received was less than the expected number of bytes).</p>

14.2.2.3 USB2.0_INTR—USB 2.0 Interrupt Enable Register

Offset: MEM_BASE + 28–2Bh Attribute: R/W
 Default Value: 00000000h Size: 32 bits

This register enables and disables reporting of the corresponding interrupt to the software. When a bit is set and the corresponding interrupt is active, an interrupt is generated to the host. Interrupt sources that are disabled in this register still appear in the USB2.0_STS Register to allow the software to poll for events. Each interrupt enable bit description indicates whether it is dependent on the interrupt threshold mechanism (see Section 4 of the EHCI specification), or not.

Bit	Description
31:6	Reserved. These bits are reserved and should be 0 when writing this register.
5	Interrupt on Async Advance Enable — R/W. 0 = Disable. 1 = Enable. When this bit is a 1, and the Interrupt on Async Advance bit (D29:F7:CAPLENGTH + 24h, bit 5) in the USB2.0_STS register is a 1, the host controller will issue an interrupt at the next interrupt threshold. The interrupt is acknowledged by software clearing the Interrupt on Async Advance bit.
4	Host System Error Enable — R/W. 0 = Disable. 1 = Enable. When this bit is a 1, and the Host System Error Status bit (D29:F7:CAPLENGTH + 24h, bit 4) in the USB2.0_STS register is a 1, the host controller will issue an interrupt. The interrupt is acknowledged by software clearing the Host System Error bit.
3	Frame List Rollover Enable — R/W. 0 = Disable. 1 = Enable. When this bit is a 1, and the Frame List Rollover bit (D29:F7:CAPLENGTH + 24h, bit 3) in the USB2.0_STS register is a 1, the host controller will issue an interrupt. The interrupt is acknowledged by software clearing the Frame List Rollover bit.
2	Port Change Interrupt Enable — R/W. 0 = Disable. 1 = Enable. When this bit is a 1, and the Port Change Detect bit (D29:F7:CAPLENGTH + 24h, bit 2) in the USB2.0_STS register is a 1, the host controller will issue an interrupt. The interrupt is acknowledged by software clearing the Port Change Detect bit.
1	USB Error Interrupt Enable — R/W. 0 = Disable. 1 = Enable. When this bit is a 1, and the USBERRINT bit (D29:F7:CAPLENGTH + 24h, bit 1) in the USB2.0_STS register is a 1, the host controller will issue an interrupt at the next interrupt threshold. The interrupt is acknowledged by software by clearing the USBERRINT bit in the USB2.0_STS register.
0	USB Interrupt Enable — R/W. 0 = Disable. 1 = Enable. When this bit is a 1, and the USBINT bit (D29:F7:CAPLENGTH + 24h, bit 0) in the USB2.0_STS register is a 1, the host controller will issue an interrupt at the next interrupt threshold. The interrupt is acknowledged by software by clearing the USBINT bit in the USB2.0_STS register.

14.2.2.4 FRINDEX—Frame Index Register

Offset: MEM_BASE + 2C–2Fh Attribute: R/W
 Default Value: 00000000h Size: 32 bits

The SOF frame number value for the bus SOF token is derived or alternatively managed from this register. Refer to Section 4 of the EHCI specification for a detailed explanation of the SOF value management requirements on the host controller. The value of FRINDEX must be within 125 μs (1 micro-frame) ahead of the SOF token value. The SOF value may be implemented as an 11-bit shadow register. For this discussion, this shadow register is 11 bits and is named SOFV. SOFV updates every 8 micro-frames. (1 millisecond). An example implementation to achieve this behavior is to increment SOFV each time the FRINDEX[2:0] increments from 0 to 1.

Software must use the value of FRINDEX to derive the current micro-frame number, both for high-speed isochronous scheduling purposes and to provide the **get** micro-frame number function required to client drivers. Therefore, the value of FRINDEX and the value of SOFV must be kept consistent if chip is reset or software writes to FRINDEX. Writes to FRINDEX must also **write-through** FRINDEX[13:3] to SOFV[10:0]. In order to keep the update as simple as possible, software should never write a FRINDEX value where the three least significant bits are 111b or 000b.

Note: This register is used by the host controller to index into the periodic frame list. The register updates every 125 microseconds (once each micro-frame). Bits [12:3] are used to select a particular entry in the Periodic Frame List during periodic schedule execution. The number of bits used for the index is fixed at 10 for the ICH6 since it only supports 1024-entry frame lists. This register must be written as a DWord. Word and byte writes produce undefined results. This register cannot be written unless the Host controller is in the Halted state as indicated by the *HCHalted* bit (D29:F7:CAPLENGTH + 24h, bit 12). A write to this register while the Run/Stop bit (D29:F7:CAPLENGTH + 20h, bit 0) is set to a 1 (USB2.0_CMD register) produces undefined results. Writes to this register also effect the SOF value. See Section 4 of the EHCI specification for details.

Bit	Description
31:14	Reserved
13:0	Frame List Current Index/Frame Number — R/W. The value in this register increments at the end of each time frame (e.g., micro-frame). Bits [12:3] are used for the Frame List current index. This means that each location of the frame list is accessed 8 times (frames or micro-frames) before moving to the next index.

14.2.2.5 CTRLDSSEGMENT—Control Data Structure Segment Register

Offset: MEM_BASE + 30–33h Attribute: R/W, RO
 Default Value: 00000000h Size: 32 bits

This 32-bit register corresponds to the most significant address bits [63:32] for all EHCI data structures. Since the ICH6 hardwires the 64-bit Addressing Capability field in HCCPARAMS to 1, then this register is used with the link pointers to construct 64-bit addresses to EHCI control data structures. This register is concatenated with the link pointer from either the PERIODICLISTBASE, ASYNCLISTADDR, or any control data structure link field to construct a 64-bit address. This register allows the host software to locate all control data structures within the same 4 GB memory segment.

Bit	Description
31:12	Upper Address[63:44] — RO. Hardwired to 0s. The ICH6 EHC is only capable of generating addresses up to 16 terabytes (44 bits of address).
11:0	Upper Address[43:32] — R/W. This 12-bit field corresponds to address bits 43:32 when forming a control data structure address.

14.2.2.6 PERIODICLISTBASE—Periodic Frame List Base Address Register

Offset: MEM_BASE + 34–37h Attribute: R/W
 Default Value: 00000000h Size: 32 bits

This 32-bit register contains the beginning address of the Periodic Frame List in the system memory. Since the ICH6 host controller operates in 64-bit mode (as indicated by the 1 in the 64-bit Addressing Capability field in the HCCSPARAMS register) (offset 08h, bit 0), then the most significant 32 bits of every control data structure address comes from the CTRLDSSEGMENT register. HCD loads this register prior to starting the schedule execution by the host controller. The memory structure referenced by this physical memory pointer is assumed to be 4-Kbyte aligned. The contents of this register are combined with the Frame Index Register (FRINDEX) to enable the Host controller to step through the Periodic Frame List in sequence.

Bit	Description
31:12	Base Address (Low) — R/W. These bits correspond to memory address signals [31:12], respectively.
11:0	Reserved. Must be written as 0's. During runtime, the value of these bits are undefined.

14.2.2.7 **ASYNCLISTADDR—Current Asynchronous List Address Register**

Offset: MEM_BASE + 38–3Bh Attribute: R/W
 Default Value: 00000000h Size: 32 bits

This 32-bit register contains the address of the next asynchronous queue head to be executed. Since the ICH6 host controller operates in 64-bit mode (as indicated by a 1 in 64-bit Addressing Capability field in the HCCPARAMS register) (offset 08h, bit 0), then the most significant 32 bits of every control data structure address comes from the CTRLDSSEGMENT register (offset 08h). Bits [4:0] of this register cannot be modified by system software and will always return 0's when read. The memory structure referenced by this physical memory pointer is assumed to be 32-byte aligned.

Bit	Description
31:5	Link Pointer Low (LPL) — R/W. These bits correspond to memory address signals [31:5], respectively. This field may only reference a Queue Head (QH).
4:0	Reserved. These bits are reserved and their value has no effect on operation.

14.2.2.8 **CONFIGFLAG—Configure Flag Register**

Offset: MEM_BASE + 60–63h Attribute: R/W
 Default Value: 00000000h Size: 32 bits

This register is in the suspend power well. It is only reset by hardware when the suspend power is initially applied or in response to a host controller reset.

Bit	Description
31:1	Reserved. Read from this field will always return 0.
0	Configure Flag (CF) — R/W. Host software sets this bit as the last action in its process of configuring the Host controller. This bit controls the default port-routing control logic. Bit values and side-effects are listed below. See section 4 of the EHCI specification for operation details. 0 = Port routing control logic default-routes each port to the classic host controllers (default). 1 = Port routing control logic default-routes all ports to this host controller.

14.2.2.9 PORTSC—Port N Status and Control Register

Offset:	Port 0: MEM_BASE + 64–67h Port 1: MEM_BASE + 68–6Bh Port 2: MEM_BASE + 6C–6Fh Port 3: MEM_BASE + 70–73h Port 4: MEM_BASE + 74–77h Port 5: MEM_BASE + 78–7Bh Port 6: MEM_BASE + 7C–7Fh Port 7: MEM_BASE + 80–83h
Attribute:	R/W, R/WC, RO
Default Value:	00003000h
Size:	32 bits

A host controller must implement one or more port registers. Software uses the N_Port information from the Structural Parameters Register to determine how many ports need to be serviced. All ports have the structure defined below. Software must not write to unreported Port Status and Control Registers.

This register is in the suspend power well. It is only reset by hardware when the suspend power is initially applied or in response to a host controller reset. The initial conditions of a port are:

- No device connected
- Port disabled.

When a device is attached, the port state transitions to the attached state and system software will process this as with any status change notification. Refer to Section 4 of the EHCI specification for operational requirements for how change events interact with port suspend mode.

Bit	Description
31:23	Reserved. These bits are reserved for future use and will return a value of 0's when read.
22	Wake on Overcurrent Enable (WKOC_E) — R/W. 0 = Disable. (Default) 1 = Enable. Writing this bit to a 1 enables the setting of the PME Status bit in the Power Management Control/Status Register (offset 54, bit 15) when the overcurrent Active bit (bit 4 of this register) is set.
21	Wake on Disconnect Enable (WKDSCNNT_E) — R/W. 0 = Disable. (Default) 1 = Enable. Writing this bit to a 1 enables the setting of the PME Status bit in the Power Management Control/Status Register (offset 54, bit 15) when the Current Connect Status changes from connected to disconnected (i.e., bit 0 of this register changes from 1 to 0).
20	Wake on Connect Enable (WKCNNNT_E) — R/W. 0 = Disable. (Default) 1 = Enable. Writing this bit to a 1 enables the setting of the PME Status bit in the Power Management Control/Status Register (offset 54, bit 15) when the Current Connect Status changes from disconnected to connected (i.e., bit 0 of this register changes from 0 to 1).

Bit	Description														
19:16	<p>Port Test Control — R/W. When this field is 0's, the port is NOT operating in a test mode. A non-zero value indicates that it is operating in test mode and the specific test mode is indicated by the specific value. The encoding of the test mode bits are (0110b – 1111b are reserved):</p> <table style="margin-left: 20px;"> <thead> <tr> <th style="text-align: left;">Value</th> <th style="text-align: left;">Maximum Interrupt Interval</th> </tr> </thead> <tbody> <tr> <td>0000b</td> <td>Test mode not enabled (default)</td> </tr> <tr> <td>0001b</td> <td>Test J_STATE</td> </tr> <tr> <td>0010b</td> <td>Test K_STATE</td> </tr> <tr> <td>0011b</td> <td>Test SE0_NAK</td> </tr> <tr> <td>0100b</td> <td>Test Packet</td> </tr> <tr> <td>0101b</td> <td>FORCE_ENABLE</td> </tr> </tbody> </table> <p>Refer to USB Specification Revision 2.0, Chapter 7 for details on each test mode.</p>	Value	Maximum Interrupt Interval	0000b	Test mode not enabled (default)	0001b	Test J_STATE	0010b	Test K_STATE	0011b	Test SE0_NAK	0100b	Test Packet	0101b	FORCE_ENABLE
Value	Maximum Interrupt Interval														
0000b	Test mode not enabled (default)														
0001b	Test J_STATE														
0010b	Test K_STATE														
0011b	Test SE0_NAK														
0100b	Test Packet														
0101b	FORCE_ENABLE														
15:14	Reserved — R/W. Should be written to =00b.														
13	<p>Port Owner — R/W. Default = 1b. This bit unconditionally goes to a 0 when the Configured Flag bit in the USB2.0_CMD register makes a 0 to 1 transition.</p> <p>System software uses this field to release ownership of the port to a selected host controller (in the event that the attached device is not a high-speed device). Software writes a 1 to this bit when the attached device is not a high-speed device. A 1 in this bit means that a companion host controller owns and controls the port. See Section 4 of the EHCI Specification for operational details.</p>														
12	Port Power (PP) — RO. Read-only with a value of 1. This indicates that the port does have power.														
11:10	<p>Line Status— RO. These bits reflect the current logical levels of the D+ (bit 11) and D– (bit 10) signal lines. These bits are used for detection of low-speed USB devices prior to the port reset and enable sequence. This field is valid only when the port enable bit is 0 and the current connect status bit is set to a 1.</p> <p>00 = SE0 10 = J-state 01 = K-state 11 = Undefined</p>														
9	Reserved. This bit will return a 0 when read.														
8	<p>Port Reset — R/W. Default = 0. When software writes a 1 to this bit (from a 0), the bus reset sequence as defined in the USB Specification, Revision 2.0 is started. Software writes a 0 to this bit to terminate the bus reset sequence. Software must keep this bit at a 1 long enough to guarantee the reset sequence completes as specified in the USB Specification, Revision 2.0.</p> <p>1 = Port is in Reset. 0 = Port is not in Reset.</p> <p>NOTE: When software writes a 0 to this bit, there may be a delay before the bit status changes to a 0. The bit status will not read as a 0 until after the reset has completed. If the port is in high-speed mode after reset is complete, the host controller will automatically enable this port (e.g., set the <i>Port Enable</i> bit to a 1). A host controller must terminate the reset and stabilize the state of the port within 2 milliseconds of software transitioning this bit from 0 to 1.</p> <p>For example: if the port detects that the attached device is high-speed during reset, then the host controller must have the port in the enabled state within 2 ms of software writing this bit to a 0. The <i>HCHalted</i> bit (D29:F7:CAPLENGTH + 24h, bit 12) in the USB2.0_STS register should be a 0 before software attempts to use this bit. The host controller may hold Port Reset asserted to a 1 when the <i>HCHalted</i> bit is a 1. This bit is 0 if Port Power is 0</p> <p>NOTE: System software should not attempt to reset a port if the <i>HCHalted</i> bit in the USB2.0_STS register is a 1. Doing so will result in undefined behavior.</p>														

Bit	Description												
7	<p>Suspend — R/W.</p> <p>0 = Port not in suspend state.(Default) 1 = Port in suspend state.</p> <p>Port Enabled Bit and Suspend bit of this register define the port states as follows:</p> <table border="1"> <thead> <tr> <th>Port Enabled</th> <th>Suspend</th> <th>Port State</th> </tr> </thead> <tbody> <tr> <td>0</td> <td>X</td> <td>Disabled</td> </tr> <tr> <td>1</td> <td>0</td> <td>Enabled</td> </tr> <tr> <td>1</td> <td>1</td> <td>Suspend</td> </tr> </tbody> </table> <p>When in suspend state, downstream propagation of data is blocked on this port, except for port reset. Note that the bit status does not change until the port is suspended and that there may be a delay in suspending a port depending on the activity on the port.</p> <p>The host controller will unconditionally set this bit to a 0 when software sets the <i>Force Port Resume</i> bit to a 0 (from a 1). A write of 0 to this bit is ignored by the host controller.</p> <p>If host software sets this bit to a 1 when the port is not enabled (i.e., Port enabled bit is a 0) the results are undefined.</p>	Port Enabled	Suspend	Port State	0	X	Disabled	1	0	Enabled	1	1	Suspend
Port Enabled	Suspend	Port State											
0	X	Disabled											
1	0	Enabled											
1	1	Suspend											
6	<p>Force Port Resume — R/W.</p> <p>0 = No resume (K-state) detected/driven on port. (Default) 1 = Resume detected/driven on port. Software sets this bit to a 1 to drive resume signaling. The Host controller sets this bit to a 1 if a J-to-K transition is detected while the port is in the Suspend state. When this bit transitions to a 1 because a J-to-K transition is detected, the Port Change Detect bit (D29:F7:CAPLENGTH + 24h, bit 2) in the USB2.0_STS register is also set to a 1. If software sets this bit to a 1, the host controller must not set the Port Change Detect bit.</p> <p>NOTE: When the EHCI controller owns the port, the resume sequence follows the defined sequence documented in the USB Specification, Revision 2.0. The resume signaling (Full-speed 'K') is driven on the port as long as this bit remains a 1. Software must appropriately time the Resume and set this bit to a 0 when the appropriate amount of time has elapsed. Writing a 0 (from 1) causes the port to return to high-speed mode (forcing the bus below the port into a high-speed idle). This bit will remain a 1 until the port has switched to the high-speed idle.</p>												
5	<p>Overcurrent Change — R/WC. The functionality of this bit is not dependent upon the port owner. Software clears this bit by writing a 1 to it.</p> <p>0 = No change. (Default) 1 = There is a change to Overcurrent Active.</p>												
4	<p>Overcurrent Active — RO.</p> <p>0 = This port does not have an overcurrent condition. (Default) 1 = This port currently has an overcurrent condition. This bit will automatically transition from 1 to 0 when the over current condition is removed. The ICH6 automatically disables the port when the overcurrent active bit is 1.</p>												
3	<p>Port Enable/Disable Change — R/WC. For the root hub, this bit gets set to a 1 only when a port is disabled due to the appropriate conditions existing at the EOF2 point (See Chapter 11 of the USB Specification for the definition of a port error). This bit is not set due to the Disabled-to-Enabled transition, nor due to a disconnect. Software clears this bit by writing a 1 to it.</p> <p>0 = No change in status. (Default). 1 = Port enabled/disabled status has changed.</p>												

Bit	Description
2	<p>Port Enabled/Disabled — R/W. Ports can only be enabled by the host controller as a part of the reset and enable. Software cannot enable a port by writing a 1 to this bit. Ports can be disabled by either a fault condition (disconnect event or other fault condition) or by host software. Note that the bit status does not change until the port state actually changes. There may be a delay in disabling or enabling a port due to other host controller and bus events.</p> <p>0 = Disable 1 = Enable (Default)</p>
1	<p>Connect Status Change — R/W/C. This bit indicates a change has occurred in the port's Current Connect Status. Software sets this bit to 0 by writing a 1 to it.</p> <p>0 = No change (Default). 1 = Change in Current Connect Status. The host controller sets this bit for all changes to the port device connect status, even if system software has not cleared an existing connect status change. For example, the insertion status changes twice before system software has cleared the changed condition, hub hardware will be "setting" an already-set bit (i.e., the bit will remain set).</p>
0	<p>Current Connect Status — RO. This value reflects the current state of the port, and may not correspond directly to the event that caused the Connect Status Change bit (Bit 1) to be set.</p> <p>0 = No device is present. (Default) 1 = Device is present on port.</p>

14.2.3 USB 2.0-Based Debug Port Register

The Debug port's registers are located in the same memory area, defined by the Base Address Register (MEM_BASE), as the standard EHCI registers. The base offset for the debug port registers (A0h) is declared in the Debug Port Base Offset Capability Register at Configuration offset 5Ah (D29:F7:offset 5Ah). The specific EHCI port that supports this debug capability (port 0) is indicated by a 4-bit field (bits 20–23) in the HCSPARAMS register of the EHCI controller. The address map of the Debug Port registers is shown in [Table 14-4](#).

Table 14-4. Debug Port Register Address Map

MEM_BASE + Offset	Mnemonic	Register Name	Default	Type
A0–A3h	CNTL_STS	Control/Status	00000000h	R/W, R/WC, RO, WO
A4–A7h	USBPID	USB PIDs	00000000h	R/W, RO
A8–ABh	DATABUF[3:0]	Data Buffer (Bytes 3:0)	00000000h	R/W
AC–AFh	DATABUF[7:4]	Data Buffer (Bytes 7:4)	00000000h	R/W
B0–B3h	CONFIG	Configuration	00007F01h	R/W

NOTES:

- All of these registers are implemented in the core well and reset by PLTRST#, EHC HCRESET, and a EHC D3-to-D0 transition.
- The hardware associated with this register provides no checks to ensure that software programs the interface correctly. How the hardware behaves when programmed illegally is undefined.

14.2.3.1 CNTL_STS—Control/Status Register

Offset: MEM_BASE + A0h Attribute: R/W, R/WC, RO, WO
 Default Value: 00000000h Size: 32 bits

Bit	Description
31	Reserved
30	OWNER_CNT — R/W. 0 = Ownership of the debug port is NOT forced to the EHCI controller (Default) 1 = Ownership of the debug port is forced to the EHCI controller (i.e. immediately taken away from the companion Classic USB Host controller) If the port was already owned by the EHCI controller, then setting this bit has no effect. This bit overrides all of the ownership-related bits in the standard EHCI registers.
29	Reserved
28	ENABLED_CNT — R/W. 0 = Software can clear this by writing a 0 to it. The hardware clears this bit for the same conditions where the Port Enable/Disable Change bit (in the PORTSC register) is set. (Default) 1 = Debug port is enabled for operation. Software can directly set this bit if the port is already enabled in the associated PORTSC register (this is enforced by the hardware).
27:17	Reserved
16	DONE_STS — R/WC. Software can clear this by writing a 1 to it. 0 = Request Not complete 1 = Set by hardware to indicate that the request is complete.

Bit	Description
15:12	LINK_ID_STS — RO. This field identifies the link interface. 0h = Hardwired. Indicates that it is a USB Debug Port.
11	Reserved. This bit returns 0 when read. Writes have no effect.
10	IN_USE_CNT — R/W. Set by software to indicate that the port is in use. Cleared by software to indicate that the port is free and may be used by other software. This bit is cleared after reset. (This bit has no affect on hardware.)
9:7	EXCEPTION_STS — RO. This field indicates the exception when the ERROR_GOOD#_STS bit is set. This field should be ignored if the ERROR_GOOD#_STS bit is 0. 000 =No Error. (Default) Note: this should not be seen, since this field should only be checked if there is an error. 001 =Transaction error: indicates the USB 2.0 transaction had an error (CRC, bad PID, timeout, etc.) 010 =Hardware error. Request was attempted (or in progress) when port was suspended or reset. All Other combinations are reserved
6	ERROR_GOOD#_STS — RO. 0 = Hardware clears this bit to 0 after the proper completion of a read or write. (Default) 1 = Error has occurred. Details on the nature of the error are provided in the Exception field.
5	GO_CNT — WO. 0 = Hardware clears this bit when hardware sets the DONE_STS bit. (Default) 1 = Causes hardware to perform a read or write request. NOTE: Writing a 1 to this bit when it is already set may result in undefined behavior.
4	WRITE_READ#_CNT — R/W. Software clears this bit to indicate that the current request is a read. Software sets this bit to indicate that the current request is a write. 0 = Read (Default) 1 = Write
3:0	DATA_LEN_CNT — R/W. This field is used to indicate the size of the data to be transferred. default = 0h. For write operations, this field is set by software to indicate to the hardware how many bytes of data in Data Buffer are to be transferred to the console. A value of 0h indicates that a zero-length packet should be sent. A value of 1–8 indicates 1–8 bytes are to be transferred. Values 9–Fh are illegal and how hardware behaves if used is undefined. For read operations, this field is set by hardware to indicate to software how many bytes in Data Buffer are valid in response to a read operation. A value of 0h indicates that a zero length packet was returned and the state of Data Buffer is not defined. A value of 1–8 indicates 1–8 bytes were received. Hardware is not allowed to return values 9–Fh. The transferring of data always starts with byte 0 in the data area and moves toward byte 7 until the transfer size is reached.

NOTES:

- Software should do Read-Modify-Write operations to this register to preserve the contents of bits not being modified. This include Reserved bits.
- To preserve the usage of RESERVED bits in the future, software should always write the same value read from the bit until it is defined. Reserved bits will always return 0 when read.

14.2.3.2 USBPID—USB PIDs Register

Offset: MEM_BASE + A4h Attribute: R/W, RO
 Default Value: 00000000h Size: 32 bits

This DWORD register is used to communicate PID information between the USB debug driver and the USB debug port. The debug port uses some of these fields to generate USB packets, and uses other fields to return PID information to the USB debug driver.

Bit	Description
31:24	Reserved: These bits will return 0 when read. Writes will have no effect.
23:16	RECEIVED_PID_STS[23:16] — RO. Hardware updates this field with the received PID for transactions in either direction. When the controller is writing data, this field is updated with the handshake PID that is received from the device. When the host controller is reading data, this field is updated with the data packet PID (if the device sent data), or the handshake PID (if the device NAKs the request). This field is valid when the hardware clears the GO_DONE#_CNT bit.
15:8	SEND_PID_CNT[15:8] — R/W. Hardware sends this PID to begin the data packet when sending data to USB (i.e., WRITE_READ#_CNT is asserted). Software typically sets this field to either DATA0 or DATA1 PID values.
7:0	TOKEN_PID_CNT[7:0] — R/W. Hardware sends this PID as the Token PID for each USB transaction. Software typically sets this field to either IN, OUT, or SETUP PID values.

14.2.3.3 DATABUF[7:0]—Data Buffer Bytes[7:0] Register

Offset: MEM_BASE + A8–AFh Attribute: R/W
 Default Value: 0000000000000000h Size: 64 bits

This register can be accessed as 8 separate 8-bit registers or 2 separate 32-bit register.

Bit	Description
63:0	DATABUFFER[63:0] — R/W. This field is the 8 bytes of the data buffer. Bits 7:0 correspond to least significant byte (byte 0). Bits 63:56 correspond to the most significant byte (byte 7). The bytes in the Data Buffer must be written with data before software initiates a write request. For a read request, the Data Buffer contains valid data when DONE_STS bit (offset A0, bit 16) is cleared by the hardware, ERROR_GOOD#_STS (offset A0, bit 6) is cleared by the hardware, and the DATA_LENGTH_CNT field (offset A0, bits 3:0) indicates the number of bytes that are valid.

14.2.3.4 CONFIG—Configuration Register

Offset: MEM_BASE + B0–B3h Attribute: R/W
 Default Value: 00007F01h Size: 32 bits

Bit	Description
31:15	Reserved
14:8	USB_ADDRESS_CNF — R/W. This 7-bit field identifies the USB device address used by the controller for all Token PID generation. (Default = 7Fh)
7:4	Reserved
3:0	USB_ENDPOINT_CNF — R/W. This 4-bit field identifies the endpoint used by the controller for all Token PID generation. (Default = 01h)

§

15 SMBus Controller Registers (D31:F3)

15.1 PCI Configuration Registers (SMBus—D31:F3)

Table 15-1. SMBus Controller PCI Register Address Map (SMBus—D31:F3)

Offset	Mnemonic	Register Name	Default	Type
00–01h	VID	Vendor Identification	8086	RO
02–03h	DID	Device Identification	266Ah	RO
04–05h	PCICMD	PCI Command	0000h	R/W, RO
06–07h	PCISTS	PCI Status	0280h	RO, R/WC
08h	RID	Revision Identification	See register description.	RO
09h	PI	Programming Interface	00h	RO
0Ah	SCC	Sub Class Code	05h	RO
0Bh	BCC	Base Class Code	0Ch	RO
20–23h	SMB_BASE	SMBus Base Address	00000001h	R/W, RO
2C–2Dh	SVID	Subsystem Vendor Identification	0000h	RO
2E–2Fh	SID	Subsystem Identification	0000h	R/WO
3Ch	INT_LN	Interrupt Line	00h	R/W
3Dh	INT_PN	Interrupt Pin	See description	RO
40h	HOSTC	Host Configuration	00h	R/W

NOTE: Registers that are not shown should be treated as Reserved (See [Section 6.2](#) for details).

15.1.1 VID—Vendor Identification Register (SMBus—D31:F3)

Address: 00–01h Attribute: RO
 Default Value: 8086h Size: 16 bits

Bit	Description
15:0	Vendor ID — RO. This is a 16-bit value assigned to Intel

15.1.2 DID—Device Identification Register (SMBus—D31:F3)

Address: 02–03h Attribute: RO
 Default Value: 266Ah Size: 16 bits

Bit	Description
15:0	Device ID — RO.

15.1.3 PCICMD—PCI Command Register (SMBus—D31:F3)

Address: 04–05h Attributes: RO, R/W
 Default Value: 0000h Size: 16 bits

Bit	Description
15:11	Reserved
10	Interrupt Disable — R/W. 0 = Enable 1 = Disables SMBus to assert its PIRQB# signal.
9	Fast Back to Back Enable (FBE) — RO. Hardwired to 0.
8	SERR# Enable (SERR_EN) — R/W. 0 = Enables SERR# generation. 1 = Disables SERR# generation.
7	Wait Cycle Control (WCC) — RO. Hardwired to 0.
6	Parity Error Response (PER) — R/W. 0 = Disable 1 = Sets Detected Parity Error bit (D31:F3:06, bit 15) when a parity error is detected.
5	VGA Palette Snoop (VPS) — RO. Hardwired to 0.
4	Postable Memory Write Enable (PMWE) — RO. Hardwired to 0.
3	Special Cycle Enable (SCE) — RO. Hardwired to 0.
2	Bus Master Enable (BME) — RO. Hardwired to 0.
1	Memory Space Enable (MSE) — RO. Hardwired to 0.
0	I/O Space Enable (IOSE) — R/W. 0 = Disable 1 = Enables access to the SM Bus I/O space registers as defined by the Base Address Register.

15.1.4 PCISTS—PCI Status Register (SMBus—D31:F3)

Address: 06–07h Attributes:RO, R/WC
 Default Value: 0280h Size: 16 bits

Note: For the writable bits, software must write a 1 to clear bits that are set. Writing a 0 to the bit has no effect.

Bit	Description
15	Detected Parity Error (DPE) — R/WC. 0 = No parity error detected. 1 = Parity error detected.
14	Signaled System Error (SSE) — R/WC. 0 = No system error detected. 1 = System error detected.
13	Received Master Abort (RMA) — RO. Hardwired to 0.
12	Received Target Abort (RTA) — RO. Hardwired to 0.
11	Signaled Target Abort (STA) — R/WC. 0 = ICH6 did Not terminate transaction for this function with a target abort. 1 = The function is targeted with a transaction that the Intel® ICH6 terminates with a target abort.
10:9	DEVSEL# Timing Status (DEVT) — RO. This 2-bit field defines the timing for DEVSEL# assertion for positive decode. 01 = Medium timing.
8	Data Parity Error Detected (DPED) — RO. Hardwired to 0.
7	Fast Back to Back Capable (FB2BC) — RO. Hardwired to 1.
6	User Definable Features (UDF) — RO. Hardwired to 0.
5	66 MHz Capable (66MHZ_CAP) — RO. Hardwired to 0.
4	Capabilities List (CAP_LIST) — RO. Hardwired to 0 because there are no capability list structures in this function
3	Interrupt Status (INTS) — RO. This bit indicates that an interrupt is pending. It is independent from the state of the Interrupt Enable bit in the PCI Command register.
2:0	Reserved

15.1.5 RID—Revision Identification Register (SMBus—D31:F3)

Offset Address: 08h Attribute: RO
 Default Value: See bit description Size: 8 bits

Bit	Description
7:0	Revision ID — RO. Refer to the <i>Intel® I/O Controller Hub 6 (ICH6) Family Specification Update</i> for the value of the Revision ID Register

15.1.6 PI—Programming Interface Register (SMBus—D31:F3)

Offset Address: 09h Attribute: RO
 Default Value: 00h Size: 8 bits

Bit	Description
7:0	Reserved

15.1.7 SCC—Sub Class Code Register (SMBus—D31:F3)

Address Offset: 0Ah Attributes: RO
 Default Value: 05h Size: 8 bits

Bit	Description
7:0	Sub Class Code (SCC) — RO. 05h = SM Bus serial controller

15.1.8 BCC—Base Class Code Register (SMBus—D31:F3)

Address Offset: 0Bh Attributes: RO
 Default Value: 0Ch Size: 8 bits

Bit	Description
7:0	Base Class Code (BCC) — RO. 0Ch = Serial controller.

15.1.9 SMB_BASE—SMBus Base Address Register (SMBus—D31:F3)

Address Offset: 20–23h Attribute: R/W, RO
 Default Value: 00000001h Size: 32-bits

Bit	Description
31:16	Reserved — RO
15:5	Base Address — R/W. This field provides the 32-byte system I/O base address for the ICH6 SMB logic.
4:1	Reserved — RO
0	IO Space Indicator — RO. Hardwired to 1 indicating that the SMB logic is I/O mapped.

15.1.10 SVID—Subsystem Vendor Identification Register (SMBus—D31:F2/F4)

Address Offset: 2Ch–2Dh Attribute:RO
 Default Value: 0000h Size: 16 bits
 Lockable: No Power Well:Core

Bit	Description
15:0	Subsystem Vendor ID (SVID) — RO. The SVID register, in combination with the Subsystem ID (SID) register, enables the operating system (OS) to distinguish subsystems from each other. The value returned by reads to this register is the same as that which was written by BIOS into the IDE SVID register. NOTE: Software can write to this register only once per core well reset. Writes should be done as a single 16-bit cycle.

15.1.11 SID—Subsystem Identification Register (SMBus—D31:F2/F4)

Address Offset: 2Eh–2Fh Attribute:R/WO
 Default Value: 0000h Size: 16 bits
 Lockable: No Power Well:Core

Bit	Description
15:0	Subsystem ID (SID) — RO. The SID register, in combination with the SVID register, enables the operating system (OS) to distinguish subsystems from each other. The value returned by reads to this register is the same as that which was written by BIOS into the IDE SID register. NOTE: Software can write to this register only once per core well reset. Writes should be done as a single 16-bit cycle.

15.1.12 INT_LN—Interrupt Line Register (SMBus—D31:F3)

Address Offset: 3Ch Attributes: R/W
 Default Value: 00h Size: 8 bits

Bit	Description
7:0	Interrupt Line (INT_LN) — R/W. This data is not used by the ICH6. It is to communicate to software the interrupt line that the interrupt pin is connected to PIRQB#.

15.1.13 INT_PN—Interrupt Pin Register (SMBus—D31:F3)

Address Offset: 3Dh Attributes: RO
 Default Value: See description Size: 8 bits

Bit	Description
7:0	Interrupt PIN (INT_PN) — RO. This field reflects the value of D31IP.SMIP in chipset configuration space.

15.1.14 HOSTC—Host Configuration Register (SMBus—D31:F3)

Address Offset: 40h
Default Value: 00h

Attribute: R/W
Size: 8 bits

Bit	Description
7:3	Reserved
2	I²C_EN — R/W. 0 = SMBus behavior. 1 = The ICH6 is enabled to communicate with I ² C devices. This will change the formatting of some commands.
1	SMB_SMI_EN — R/W. 0 = SMBus interrupts will not generate an SMI#. 1 = Any source of an SMB interrupt will instead be routed to generate an SMI#. Refer to Section 5.21.4 (Interrupts / SMI#). This bit needs to be set for SMBALERT# to be enabled.
0	SMBus Host Enable (HST_EN) — R/W. 0 = Disable the SMBus Host controller. 1 = Enable. The SMB Host controller interface is enabled to execute commands. The INTREN bit (offset SMBASE + 02h, bit 0) needs to be enabled for the SMB Host controller to interrupt or SMI#. Note that the SMB Host controller will not respond to any new requests until all interrupt requests have been cleared.

15.2 SMBus I/O Registers

Table 15-2. SMBus I/O Register Address Map

SMB_BASE + Offset	Mnemonic	Register Name	Default	Type
00h	HST_STS	Host Status	00h	R/WC, RO, R/WC (special)
02h	HST_CNT	Host Control	00h	R/W, WO
03h	HST_CMD	Host Command	00h	R/W
04h	XMIT_SLVA	Transmit Slave Address	00h	R/W
05h	HST_D0	Host Data 0	00h	R/W
06h	HST_D1	Host Data 1	00h	R/W
07h	HOST_BLOCK_DB	Host Block Data Byte	00h	R/W
08h	PEC	Packet Error Check	00h	R/W
09h	RCV_SLVA	Receive Slave Address	44h	R/W
0A–0Bh	SLV_DATA	Receive Slave Data	0000h	RO
0Ch	AUX_STS	Auxiliary Status	00h	R/WC, RO
0Dh	AUX_CTL	Auxiliary Control	00h	R/W
0Eh	SMLINK_PIN_CTL	SMLink Pin Control (TCO Compatible Mode)	See register description	R/W, RO
0Fh	SMBus_PIN_CTL	SMBus Pin Control	See register description	R/W, RO
10h	SLV_STS	Slave Status	00h	R/WC
11h	SLV_CMD	Slave Command	00h	R/W
14h	NOTIFY_DADDR	Notify Device Address	00h	RO
16h	NOTIFY_DLOW	Notify Data Low Byte	00h	RO
17h	NOTIFY_DHIGH	Notify Data High Byte	00h	RO

15.2.1 HST_STS—Host Status Register (SMBus—D31:F3)

Register Offset: SMBASE + 00h Attribute: R/WC, R/WC (special), RO
 Default Value: 00h Size: 8-bits

All status bits are set by hardware and cleared by the software writing a one to the particular bit position. Writing a 0 to any bit position has no effect.

Bit	Description
7	<p>Byte Done Status (DS) — R/WC.</p> <p>0 = Software can clear this by writing a 1 to it. 1 = Host controller received a byte (for Block Read commands) or if it has completed transmission of a byte (for Block Write commands) when the 32-byte buffer is not being used. Note that this bit will be set, even on the last byte of the transfer. This bit is not set when transmission is due to the LAN interface heartbeat.</p> <p>This bit has no meaning for block transfers when the 32-byte buffer is enabled.</p> <p>NOTE: When the last byte of a block message is received, the host controller will set this bit. However, it will not immediately set the INTR bit (bit 1 in this register). When the interrupt handler clears the DS bit, the message is considered complete, and the host controller will then set the INTR bit (and generate another interrupt). Thus, for a block message of n bytes, the ICH6 will generate n+1 interrupts. The interrupt handler needs to be implemented to handle these cases.</p>
6	<p>INUSE_STS — R/WC (special). This bit is used as semaphore among various independent software threads that may need to use the ICH6's SMBus logic, and has no other effect on hardware.</p> <p>0 = After a full PCI reset, a read to this bit returns a 0. 1 = After the first read, subsequent reads will return a 1. A write of a 1 to this bit will reset the next read value to 0. Writing a 0 to this bit has no effect. Software can poll this bit until it reads a 0, and will then own the usage of the host controller.</p>
5	<p>SMBALERT_STS — R/WC.</p> <p>0 = Interrupt or SMI# was not generated by SMBALERT#. Software clears this bit by writing a 1 to it. 1 = The source of the interrupt or SMI# was the SMBALERT# signal. This bit is only cleared by software writing a 1 to the bit position or by RSMRST# going low.</p> <p>If the signal is programmed as a GPI, then this bit will never be set.</p>
4	<p>FAILED — R/WC.</p> <p>0 = Software clears this bit by writing a 1 to it. 1 = The source of the interrupt or SMI# was a failed bus transaction. This bit is set in response to the KILL bit being set to terminate the host transaction.</p>
3	<p>BUS_ERR — R/WC.</p> <p>0 = Software clears this bit by writing a 1 to it. 1 = The source of the interrupt or SMI# was a transaction collision.</p>

Bit	Description
2	DEV_ERR — R/WC. 0 = Software clears this bit by writing a 1 to it. The ICH6 will then de-assert the interrupt or SMI#. 1 = The source of the interrupt or SMI# was due to one of the following: <ul style="list-style-type: none"> •Illegal Command Field, •Unclaimed Cycle (host initiated), •Host Device Time-out Error.
1	INTR — R/WC (special). This bit can only be set by termination of a command. INTR is not dependent on the INTREN bit (offset SMBASE + 02h, bit 0) of the Host controller register (offset 02h). It is only dependent on the termination of the command. If the INTREN bit is not set, then the INTR bit will be set, although the interrupt will not be generated. Software can poll the INTR bit in this non-interrupt case. 0 = Software clears this bit by writing a 1 to it. The ICH6 then de-asserts the interrupt or SMI#. 1 = The source of the interrupt or SMI# was the successful completion of its last command.
0	HOST_BUSY — RO. 0 = Cleared by the ICH6 when the current transaction is completed. 1 = Indicates that the ICH6 is running a command from the host interface. No SMB registers should be accessed while this bit is set, except the BLOCK DATA BYTE Register. The BLOCK DATA BYTE Register can be accessed when this bit is set only when the SMB_CMD bits in the Host Control Register are programmed for Block command or I ² C Read command. This is necessary in order to check the DONE_STS bit.

15.2.2 HST_CNT—Host Control Register (SMBus—D31:F3)

Register Offset: SMBASE + 02h Attribute: R/W, WO
 Default Value: 00h Size: 8-bits

Note: A read to this register will clear the byte pointer of the 32-byte buffer.

Bit	Description
7	PEC_EN. — R/W. 0 = SMBus host controller does not perform the transaction with the PEC phase appended. 1 = Causes the host controller to perform the SMBus transaction with the Packet Error Checking phase appended. For writes, the value of the PEC byte is transferred from the PEC Register. For reads, the PEC byte is loaded in to the PEC Register. This bit must be written prior to the write in which the START bit is set.
6	START — WO. 0 = This bit will always return 0 on reads. The HOST_BUSY bit in the Host Status register (offset 00h) can be used to identify when the Intel [®] ICH6 has finished the command. 1 = Writing a 1 to this bit initiates the command described in the SMB_CMD field. All registers should be setup prior to writing a 1 to this bit position.
5	LAST_BYTE — WO. This bit is used for Block Read commands. 1 = Software sets this bit to indicate that the next byte will be the last byte to be received for the block. This causes the ICH6 to send a NACK (instead of an ACK) after receiving the last byte. NOTE: Once the SECOND_TO_STS bit in TCO2_STS register (D31:F0, TCOBASE+6h, bit 1) is set, the LAST_BYTE bit also gets set. While the SECOND_TO_STS bit is set, the LAST_BYTE bit cannot be cleared. This prevents the ICH6 from running some of the SMBus commands (Block Read/Write, I ² C Read, Block I ² C Write).

Bit	Description
4:2	<p>SMB_CMD — R/W. The bit encoding below indicates which command the ICH6 is to perform. If enabled, the ICH6 will generate an interrupt or SMI# when the command has completed. If the value is for a non-supported or reserved command, the ICH6 will set the device error (DEV_ERR) status bit (offset SMBASE + 00h, bit 2) and generate an interrupt when the START bit is set. The ICH6 will perform no command, and will not operate until DEV_ERR is cleared.</p> <p>000 = Quick: The slave address and read/write value (bit 0) are stored in the transmit slave address register.</p> <p>001 = Byte: This command uses the transmit slave address and command registers. Bit 0 of the slave address register determines if this is a read or write command.</p> <p>010 = Byte Data: This command uses the transmit slave address, command, and DATA0 registers. Bit 0 of the slave address register determines if this is a read or write command. If it is a read, the DATA0 register will contain the read data.</p> <p>011 = Word Data: This command uses the transmit slave address, command, DATA0 and DATA1 registers. Bit 0 of the slave address register determines if this is a read or write command. If it is a read, after the command completes, the DATA0 and DATA1 registers will contain the read data.</p> <p>100 = Process Call: This command uses the transmit slave address, command, DATA0 and DATA1 registers. Bit 0 of the slave address register determines if this is a read or write command. After the command completes, the DATA0 and DATA1 registers will contain the read data.</p> <p>101 = Block: This command uses the transmit slave address, command, DATA0 registers, and the Block Data Byte register. For block write, the count is stored in the DATA0 register and indicates how many bytes of data will be transferred. For block reads, the count is received and stored in the DATA0 register. Bit 0 of the slave address register selects if this is a read or write command. For writes, data is retrieved from the first n (where n is equal to the specified count) addresses of the SRAM array. For reads, the data is stored in the Block Data Byte register.</p> <p>110 = I²C Read: This command uses the transmit slave address, command, DATA0, DATA1 registers, and the Block Data Byte register. The read data is stored in the Block Data Byte register. The ICH6 continues reading data until the NAK is received.</p> <p>111 = Block Process: This command uses the transmit slave address, command, DATA0 and the Block Data Byte register. For block write, the count is stored in the DATA0 register and indicates how many bytes of data will be transferred. For block read, the count is received and stored in the DATA0 register. Bit 0 of the slave address register always indicate a write command. For writes, data is retrieved from the first m (where m is equal to the specified count) addresses of the SRAM array. For reads, the data is stored in the Block Data Byte register.</p> <p>NOTE: E32B bit in the Auxiliary Control register must be set for this command to work.</p>
1	<p>KILL — R/W.</p> <p>0 = Normal SMBus host controller functionality.</p> <p>1 = Kills the current host transaction taking place, sets the FAILED status bit, and asserts the interrupt (or SMI#). This bit, once set, must be cleared by software to allow the SMBus host controller to function normally.</p>
0	<p>INTREN — R/W.</p> <p>0 = Disable.</p> <p>1 = Enable the generation of an interrupt or SMI# upon the completion of the command.</p>

15.2.3 HST_CMD—Host Command Register (SMBus—D31:F3)

Register Offset: SMBASE + 03h Attribute: R/W
 Default Value: 00h Size: 8 bits

Bit	Description
7:0	This 8-bit field is transmitted by the host controller in the command field of the SMBus protocol during the execution of any command.

15.2.4 XMIT_SLVA—Transmit Slave Address Register (SMBus—D31:F3)

Register Offset: SMBASE + 04h Attribute: R/W
 Default Value: 00h Size: 8 bits

This register is transmitted by the host controller in the slave address field of the SMBus protocol.

Bit	Description
7:1	Address — R/W. This field provides a 7-bit address of the targeted slave.
0	RW — R/W. Direction of the host transfer. 0 = Write 1 = Read

15.2.5 HST_D0—Host Data 0 Register (SMBus—D31:F3)

Register Offset: SMBASE + 05h Attribute: R/W
 Default Value: 00h Size: 8 bits

Bit	Description
7:0	Data0/Count — R/W. This field contains the 8-bit data sent in the DATA0 field of the SMBus protocol. For block write commands, this register reflects the number of bytes to transfer. This register should be programmed to a value between 1 and 32 for block counts. A count of 0 or a count above 32 will result in unpredictable behavior. The host controller does not check or log illegal block counts.

15.2.6 HST_D1—Host Data 1 Register (SMBus—D31:F3)

Register Offset: SMBASE + 06h Attribute: R/W
 Default Value: 00h Size: 8 bits

Bit	Description
7:0	Data1 — R/W. This 8-bit register is transmitted in the DATA1 field of the SMBus protocol during the execution of any command.

15.2.7 Host_BLOCK_DB—Host Block Data Byte Register (SMBus—D31:F3)

Register Offset: SMBASE + 07h Attribute: R/W
 Default Value: 00h Size: 8 bits

Bit	Description
7:0	<p>Block Data (BDTA) — R/W. This is either a register, or a pointer into a 32-byte block array, depending upon whether the E32B bit is set in the Auxiliary Control register. When the E32B bit (offset SMBASE + 0Dh, bit 1) is cleared, this is a register containing a byte of data to be sent on a block write or read from on a block read, just as it behaved on the ICH3.</p> <p>When the E32B bit is set, reads and writes to this register are used to access the 32-byte block data storage array. An internal index pointer is used to address the array, which is reset to 0 by reading the HCTL register (offset 02h). The index pointer then increments automatically upon each access to this register. The transfer of block data into (read) or out of (write) this storage array during an SMBus transaction always starts at index address 0.</p> <p>When the E2B bit is set, for writes, software will write up to 32-bytes to this register as part of the setup for the command. After the Host controller has sent the Address, Command, and Byte Count fields, it will send the bytes in the SRAM pointed to by this register.</p> <p>When the E2B bit is cleared for writes, software will place a single byte in this register. After the host controller has sent the address, command, and byte count fields, it will send the byte in this register. If there is more data to send, software will write the next series of bytes to the SRAM pointed to by this register and clear the DONE_STS bit. The controller will then send the next byte. During the time between the last byte being transmitted to the next byte being transmitted, the controller will insert wait-states on the interface.</p> <p>When the E2B bit is set for reads, after receiving the byte count into the Data0 register, the first series of data bytes go into the SRAM pointed to by this register. If the byte count has been exhausted or the 32-byte SRAM has been filled, the controller will generate an SMI# or interrupt (depending on configuration) and set the DONE_STS bit. Software will then read the data. During the time between when the last byte is read from the SRAM to when the DONE_STS bit is cleared, the controller will insert wait-states on the interface.</p>

15.2.8 PEC—Packet Error Check (PEC) Register (SMBus—D31:F3)

Register Offset: SMBASE + 08h Attribute: R/W
 Default Value: 00h Size: 8 bits

Bit	Description
7:0	<p>PEC_DATA — R/W. This 8-bit register is written with the 8-bit CRC value that is used as the SMBus PEC data prior to a write transaction. For read transactions, the PEC data is loaded from the SMBus into this register and is then read by software. Software must ensure that the INUSE_STS bit is properly maintained to avoid having this field over-written by a write transaction following a read transaction.</p>

15.2.9 RCV_SLVA—Receive Slave Address Register (SMBus—D31:F3)

Register Offset: SMBASE + 09h Attribute: R/W
 Default Value: 44h Size: 8 bits
 Lockable: No Power Well: Resume

Bit	Description
7	Reserved
6:0	SLAVE_ADDR — R/W. This field is the slave address that the Intel® ICH6 decodes for read and write cycles. the default is not 0, so the SMBus Slave Interface can respond even before the processor comes up (or if the processor is dead). This register is cleared by RSMRST#, but not by PLTRST#.

15.2.10 SLV_DATA—Receive Slave Data Register (SMBus—D31:F3)

Register Offset: SMBASE + 0Ah–0Bh Attribute: RO
 Default Value: 0000h Size: 16 bits
 Lockable: No Power Well: Resume

This register contains the 16-bit data value written by the external SMBus master. The processor can then read the value from this register. This register is reset by RSMRST#, but not PLTRST#

Bit	Description
15:8	Data Message Byte 1 (DATA_MSG1) — RO. See Section 5.21.7 for a discussion of this field.
7:0	Data Message Byte 0 (DATA_MSG0) — RO. See Section 5.21.7 for a discussion of this field.

15.2.11 AUX_STS—Auxiliary Status Register (SMBus—D31:F3)

Register Offset: SMBASE + 0Ch Attribute: R/WC, RO
 Default Value: 00h Size: 8 bits
 Lockable: No Power Well: Resume

Bit	Description
7:2	Reserved
1	SMBus TCO Mode (STCO) — RO. This bit reflects the strap setting of TCO compatible mode vs. Advanced TCO mode. 0 = Intel® ICH6 is in the compatible TCO mode. 1 = ICH6 is in the advanced TCO mode.
0	CRC Error (CRCE) — R/WC. 0 = Software clears this bit by writing a 1 to it. 1 = This bit is set if a received message contained a CRC error. When this bit is set, the DERR bit of the host status register will also be set. This bit will be set by the controller if a software abort occurs in the middle of the CRC portion of the cycle or an abort happens after the ICH6 has received the final data bit transmitted by an external slave.

15.2.12 AUX_CTL—Auxiliary Control Register (SMBus—D31:F3)

Register Offset:	SMBASE + 0Dh	Attribute:	R/W
Default Value:	00h	Size:	8 bits
Lockable:	No	Power Well:	Resume

Bit	Description
7:2	Reserved
1	Enable 32-Byte Buffer (E32B) — R/W. 0 = Disable. 1 = Enable. When set, the Host Block Data register is a pointer into a 32-byte buffer, as opposed to a single register. This enables the block commands to transfer or receive up to 32-bytes before the ICH6 generates an interrupt.
0	Automatically Append CRC (AAC) — R/W. 0 = ICH6 will Not automatically append the CRC. 1 = The ICH6 will automatically append the CRC. This bit must not be changed during SMBus transactions or undetermined behavior will result. It should be programmed only once during the lifetime of the function.

15.2.13 SMLINK_PIN_CTL—SMLink Pin Control Register (SMBus—D31:F3)

Register Offset:	SMBASE + 0Eh	Attribute:	R/W, RO
Default Value:	See below	Size:	8 bits

Note: This register is in the resume well and is reset by RSMRST#.

This register is only applicable in the TCO compatible mode.

Bit	Description
7:3	Reserved
2	SMLINK_CLK_CTL — R/W. 0 = ICH6 will drive the SMLINK0 pin low, independent of what the other SMLINK logic would otherwise indicate for the SMLINK0 pin. 1 = The SMLINK0 pin is not overdriven low. The other SMLINK logic controls the state of the pin. (Default)
1	SMLINK1_CUR_STS — RO. This read-only bit has a default value that is dependent on an external signal level. This pin returns the value on the SMLINK1 pin. This allows software to read the current state of the pin. 0 = Low 1 = High
0	SMLINK0_CUR_STS — RO. This read-only bit has a default value that is dependent on an external signal level. This pin returns the value on the SMLINK0 pin. This allows software to read the current state of the pin. 0 = Low 1 = High

15.2.14 SMBus_PIN_CTL—SMBus Pin Control Register (SMBus—D31:F3)

Register Offset: SMBASE + 0Fh Attribute: R/W, RO
 Default Value: See below Size: 8 bits

Note: This register is in the resume well and is reset by RSMRST#.

Bit	Description
7:3	Reserved
2	SMBCLK_CTL — R/W. 1 = The SMBCLK pin is not overdriven low. The other SMBus logic controls the state of the pin. 0 = ICH6 drives the SMBCLK pin low, independent of what the other SMB logic would otherwise indicate for the SMBCLK pin. (Default)
1	SMBDATA_CUR_STS — RO. This read-only bit has a default value that is dependent on an external signal level. This pin returns the value on the SMBDATA pin. This allows software to read the current state of the pin. 0 = Low 1 = High
0	SMBCLK_CUR_STS — RO. This read-only bit has a default value that is dependent on an external signal level. This pin returns the value on the SMBCLK pin. This allows software to read the current state of the pin. 0 = Low 1 = High

15.2.15 SLV_STS—Slave Status Register (SMBus—D31:F3)

Register Offset: SMBASE + 10h Attribute: R/WC
 Default Value: 00h Size: 8 bits

Note: This register is in the resume well and is reset by RSMRST#.

All bits in this register are implemented in the 64 kHz clock domain. Therefore, software must poll this register until a write takes effect before assuming that a write has completed internally.

Bit	Description
7:1	Reserved
0	HOST_NOTIFY_STS — R/WC. The ICH6 sets this bit to a 1 when it has completely received a successful Host Notify Command on the SMLink pins. Software reads this bit to determine that the source of the interrupt or SMI# was the reception of the Host Notify Command. Software clears this bit after reading any information needed from the Notify address and data registers by writing a 1 to this bit. Note that the ICH6 will allow the Notify Address and Data registers to be over-written once this bit has been cleared. When this bit is 1, the ICH6 will NACK the first byte (host address) of any new “Host Notify” commands on the SMLink. Writing a 0 to this bit has no effect.

15.2.16 SLV_CMD—Slave Command Register (SMBus—D31:F3)

Register Offset: SMBASE + 11h Attribute: R/W
 Default Value: 00h Size: 8 bits

Note: This register is in the resume well and is reset by RSMRST#.

Bit	Description
7:2	Reserved
2	SMBALERT_DIS — R/W. 0 = Allows the generation of the interrupt or SMI#. 1 = Software sets this bit to block the generation of the interrupt or SMI# due to the SMBALERT# source. This bit is logically inverted and ANDed with the SMBALERT_STS bit (offset SMBASE + 00h, bit 5). The resulting signal is distributed to the SMI# and/or interrupt generation logic. This bit does not effect the wake logic.
1	HOST_NOTIFY_WKEN — R/W. Software sets this bit to 1 to enable the reception of a Host Notify command as a wake event. When enabled this event is “OR”ed in with the other SMBus wake events and is reflected in the SMB_WAK_STS bit of the General Purpose Event 0 Status register. 0 = Disable 1 = Enable
0	HOST_NOTIFY_INTREN — R/W. Software sets this bit to 1 to enable the generation of interrupt or SMI# when HOST_NOTIFY_STS (offset SMBASE + 10h, bit 0) is 1. This enable does not affect the setting of the HOST_NOTIFY_STS bit. When the interrupt is generated, either PIRQB# or SMI# is generated, depending on the value of the SMB_SMI_EN bit (D31:F3:40h, bit 1). If the HOST_NOTIFY_STS bit is set when this bit is written to a 1, then the interrupt (or SMI#) will be generated. The interrupt (or SMI#) is logically generated by AND’ing the STS and INTREN bits. 0 = Disable 1 = Enable

15.2.17 NOTIFY_DADDR—Notify Device Address Register (SMBus—D31:F3)

Register Offset: SMBASE + 14h Attribute: RO
 Default Value: 00h Size: 8 bits

Note: This register is in the resume well and is reset by RSMRST#.

Bit	Description
7:1	DEVICE_ADDRESS — RO. This field contains the 7-bit device address received during the Host Notify protocol of the SMBus 2.0 Specification. Software should only consider this field valid when the HOST_NOTIFY_STS bit (D31:F3:SMBASE +10, bit 0) is set to 1.
0	Reserved

15.2.18 NOTIFY_DLOW—Notify Data Low Byte Register (SMBus—D31:F3)

Register Offset: SMBASE + 16h Attribute: RO
 Default Value: 00h Size: 8 bits

Note: This register is in the resume well and is reset by RSMRST#.

Bit	Description
7:0	DATA_LOW_BYTE — RO. This field contains the first (low) byte of data received during the Host Notify protocol of the SMBus 2.0 specification. Software should only consider this field valid when the HOST_NOTIFY_STS bit (D31:F3:SMBASE +10, bit 0) is set to 1.

15.2.19 NOTIFY_DHIGH—Notify Data High Byte Register (SMBus—D31:F3)

Register Offset: SMBASE + 17h Attribute: RO
 Default Value: 00h Size: 8 bits

Note: This register is in the resume well and is reset by RSMRST#.

Bit	Description
7:0	DATA_HIGH_BYTE — RO. This field contains the second (high) byte of data received during the Host Notify protocol of the SMBus 2.0 specification. Software should only consider this field valid when the HOST_NOTIFY_STS bit (D31:F3:SMBASE +10, bit 0) is set to 1.

§



16 AC '97 Audio Controller Registers (D30:F2)

16.1 AC '97 Audio PCI Configuration Space (Audio—D30:F2)

Note: Registers that are not shown should be treated as Reserved.

Table 16-1. AC '97 Audio PCI Register Address Map (Audio—D30:F2)

Offset	Mnemonic	Register Name	Default	Access
00–01h	VID	Vendor Identification	8086h	RO
02–03h	DID	Device Identification	266Eh	RO
04–05h	PCICMD	PCI Command	0000h	R/W, RO
06–07h	PCISTS	PCI Status	0280h	R/WC, RO
08h	RID	Revision Identification	See register description	RO
09h	PI	Programming Interface	00	RO
0Ah	SCC	Sub Class Code	01h	RO
0Bh	BCC	Base Class Code	04h	RO
0Eh	HEADTYP	Header Type	00h	RO
10–13h	NAMBBAR	Native Audio Mixer Base Address	00000001h	R/W, RO
14–17h	NAMMBAR	Native Audio Bus Mastering Base Address	00000001h	R/W, RO
18–1Bh	MMBAR	Mixer Base Address (Mem)	00000000h	R/W, RO
1C–1Fh	MBBAR	Bus Master Base Address (Mem)	00000000h	R/W, RO
2C–2Dh	SVID	Subsystem Vendor Identification	0000h	R/WO
2E–2Fh	SID	Subsystem Identification	0000h	R/WO
34h	CAP_PTR	Capabilities Pointer	50h	RO
3Ch	INT_LN	Interrupt Line	00h	R/W
3Dh	INT_PN	Interrupt Pin	See register description	RO
40h	PCID	Programmable Codec ID	09h	R/W
41h	CFG	Configuration	00h	R/W
50–51h	PID	PCI Power Management Capability ID	0001h	RO
52–53h	PC	PC -Power Management Capabilities	C9C2h	RO
54–55h	PCS	Power Management Control and Status	0000h	R/W, R/WC

Note: Internal reset as a result of D3_{HOT} to D0 transition will reset all the core well registers except the following BIOS programmed registers as BIOS may not be invoked following the D3-to-D0 transition. All resume well registers will not be reset by the D3_{HOT} to D0 transition.

Core well registers **not** reset by the D3_{HOT} to D0 transition:

- offset 2Ch–2Dh – Subsystem Vendor ID (SVID)
- offset 2Eh–2Fh – Subsystem ID (SID)
- offset 40h – Programmable Codec ID (PCID)
- offset 41h – Configuration (CFG)

Resume well registers **will not** be reset by the D3_{HOT} to D0 transition:

- offset 54h–55h – Power Management Control and Status (PCS)
- Bus Mastering Register: Global Status Register, bits 17:16
- Bus Mastering Register: SDATA_IN MAP register, bits 7:3

16.1.1 VID—Vendor Identification Register (Audio—D30:F2)

Offset:	00–01h	Attribute:	RO
Default Value:	8086h	Size:	16 Bits
Lockable:	No	Power Well:	Core

Bit	Description
15:0	Vendor ID. This is a 16-bit value assigned to Intel.

16.1.2 DID—Device Identification Register (Audio—D30:F2)

Offset:	02–03h	Attribute:	RO
Default Value:	266Eh	Size:	16 Bits
Lockable:	No	Power Well:	Core

Bit	Description
15:0	Device ID.

16.1.3 PCICMD—PCI Command Register (Audio—D30:F2)

Address Offset:	04–05h	Attribute:	R/W, RO
Default Value:	0000h	Size:	16 bits
Lockable:	No	Power Well:	Core

PCICMD is a 16-bit control register. Refer to the PCI 2.3 specification for complete details on each bit.

Bit	Description
15:11	Reserved. Read 0.
10	Interrupt Disable (ID) — R/W. 0 = The INTx# signals may be asserted and MSIs may be generated. 1 = The AC '97 controller's INTx# signal will be de-asserted and it may not generate MSIs.
9	Fast Back to Back Enable (FBE) — RO. Not implemented. Hardwired to 0.
8	SERR# Enable (SERR_EN) — RO. Not implemented. Hardwired to 0.
7	Wait Cycle Control (WCC) — RO. Not implemented. Hardwired to 0.
6	Parity Error Response (PER) — RO. Not implemented. Hardwired to 0.
5	VGA Palette Snoop (VPS). Not implemented. Hardwired to 0.
4	Memory Write and Invalidate Enable (MWIE) — RO. Not implemented. Hardwired to 0.
3	Special Cycle Enable (SCE). Not implemented. Hardwired to 0.
2	Bus Master Enable (BME) — R/W. Controls standard PCI bus mastering capabilities. 0 = Disable 1 = Enable
1	Memory Space Enable (MSE) — R/W. Enables memory space addresses to the AC '97 Audio controller. 0 = Disable 1 = Enable
0	I/O Space Enable (IOSE) — R/W. This bit controls access to the AC '97 Audio controller I/O space registers. 0 = Disable (Default). 1 = Enable access to I/O space. The Native PCI Mode Base Address register should be programmed prior to setting this bit. NOTE: This bit becomes writable when the IOSE bit in offset 41h is set. If at any point software decides to clear the IOSE bit, software must first clear the IOS bit.

16.1.4 PCISTS—PCI Status Register (Audio—D30:F2)

Offset:	06–07h	Attribute:	RO, R/WC
Default Value:	0280h	Size:	16 bits
Lockable:	No	Power Well:	Core

PCISTA is a 16-bit status register. Refer to the PCI 2.3 specification for complete details on each bit.

Bit	Description
15	Detected Parity Error (DPE). Not implemented. Hardwired to 0.
14	Signaled System Error (SSE) — RO. Not implemented. Hardwired to 0.
13	Master Abort Status (MAS) — R/WC. Software clears this bit by writing a 1 to it. 0 = No master abort generated. 1 = Bus Master AC '97 2.3 interface function, as a master, generates a master abort.
12	Reserved — RO. Will always read as 0.
11	Signaled Target Abort (STA) — RO. Not implemented. Hardwired to 0.
10:9	DEVSEL# Timing Status (DEV_STS) — RO. This 2-bit field reflects the ICH6's DEVSEL# timing when performing a positive decode. 01b = Medium timing.
8	Data Parity Error Detected (DPED) — RO. Not implemented. Hardwired to 0.
7	Fast Back to Back Capable (FB2BC) — RO. Hardwired to 1. This bit indicates that the ICH6 as a target is capable of fast back-to-back transactions.
6	UDF Supported — RO. Not implemented. Hardwired to 0.
5	66 MHz Capable (66MHZ_CAP) — RO. Hardwired to 0.
4	Capabilities List (CAP_LIST) — RO. Indicates that the controller contains a capabilities pointer list. The first item is pointed to by looking at configuration offset 34h.
3	Interrupt Status (IS) — RO. 0 = This bit is 0 after the interrupt is cleared. 1 = This bit is 1 when the INTx# is asserted.
2:0	Reserved.

16.1.5 RID—Revision Identification Register (Audio—D30:F2)

Offset: 08h Attribute: RO
 Default Value: See bit description Size: 8 Bits
 Lockable: No Power Well: Core

Bit	Description
7:0	Revision ID — RO. Refer to the <i>Intel® I/O Controller Hub 6 (ICH6) Family Specification Update</i> for the value of the Revision ID Register

16.1.6 PI—Programming Interface Register (Audio—D30:F2)

Offset: 09h Attribute: RO
 Default Value: 00h Size: 8 bits
 Lockable: No Power Well: Core

Bit	Description
7:0	Programming Interface — RO.

16.1.7 SCC—Sub Class Code Register (Audio—D30:F2)

Address Offset: 0Ah Attribute: RO
 Default Value: 01h Size: 8 bits
 Lockable: No Power Well: Core

Bit	Description
7:0	Sub Class Code (SCC) — RO. 01h = Audio Device

16.1.8 BCC—Base Class Code Register (Audio—D30:F2)

Address Offset: 0Bh Attribute: RO
 Default Value: 04h Size: 8 bits
 Lockable: No Power Well: Core

Bit	Description
7:0	Base Class Code (BCC) — RO. 04h = Multimedia device

16.1.9 HEADTYP—Header Type Register (Audio—D30:F2)

Address Offset:	0Eh	Attribute:	RO
Default Value:	00h	Size:	8 bits
Lockable:	No	Power Well:	Core

Bit	Description
7:0	Header Type — RO. Hardwired to 00h.

16.1.10 NAMBAR—Native Audio Mixer Base Address Register (Audio—D30:F2)

Address Offset:	10–13h	Attribute:	R/W, RO
Default Value:	0000001h	Size:	32 bits
Lockable:	No	Power Well:	Core

The Native PCI Mode Audio function uses PCI Base Address register #1 to request a contiguous block of I/O space that is to be used for the Native Audio Mixer software interface. The mixer requires 256 bytes of I/O space. Native Audio Mixer and Modem codec I/O registers are located from 00h to 7Fh and reside in the codec. Access to these registers will be decoded by the AC '97 controller and forwarded over the AC-link to the codec. The codec will then respond with the register value.

In the case of the split codec implementation, accesses to the different codecs are differentiated by the controller by using address offsets 00h–7Fh for the primary codec and address offsets 80h–FEh for the secondary codec.

Note: The tertiary codec cannot be addressed via this address space. The tertiary space is only available from the new MMBAR register. This register powers up as read only and only becomes write-able when the IOSE bit in offset 41h is set.

For description of these I/O registers, refer to the *Audio Codec '97 Component Specification, Version 2.3*.

Bit	Description
31:16	Hardwired to 0's.
15:8	Base Address — R/W. These bits are used in the I/O space decode of the Native Audio Mixer interface registers. The number of upper bits that a device actually implements depends on how much of the address space the device will respond to. For the AC '97 mixer, the upper 16 bits are hardwired to 0, while bits 15:8 are programmable. This configuration yields a maximum I/O block size of 256 bytes for this base address.
7:1	Reserved. Read as 0's.
0	Resource Type Indicator (RTE) — RO. This bit defaults to 0 and changes to 1 if the IOSE bit is set (D30:F2:Offset 41h, bit 0). When 1, this bit indicates a request for I/O space.

16.1.11 NABMBAR—Native Audio Bus Mastering Base Address Register (Audio—D30:F2)

Address Offset:	14–17h	Attribute:	R/W, RO
Default Value:	00000001h	Size:	32 bits
Lockable:	No	Power Well:	Core

The Native PCI Mode Audio function uses PCI Base Address register #1 to request a contiguous block of I/O space that is to be used for the Native Mode Audio software interface.

Note: The DMA registers for S/PDIF* and Microphone In 2 cannot be addressed via this address space. These DMA functions are only available from the new MBBAR register. This register powers up as read only and only becomes write-able when the IOSE bit in offset 41h is set.

Bit	Description
31:16	Hardwired to 0's
15:6	Base Address — R/W. These bits are used in the I/O space decode of the Native Audio Bus Mastering interface registers. The number of upper bits that a device actually implements depends on how much of the address space the device will respond to. For AC '97 bus mastering, the upper 16 bits are hardwired to 0, while bits 15:6 are programmable. This configuration yields a maximum I/O block size of 64 bytes for this base address.
5:1	Reserved. Read as 0's.
0	Resource Type Indicator (RTE) — RO. This bit defaults to 0 and changes to 1 if the IOSE bit is set (D30:F2:Offset 41h, bit 0). When 1, this bit indicates a request for I/O space.

16.1.12 MMBAR—Mixer Base Address Register (Audio—D30:F2)

Address Offset:	18–1Bh	Attribute:	R/W, RO
Default Value:	00000000h	Size:	32 bits
Lockable:	No	Power Well:	Core

This BAR creates 512 bytes of memory space to signify the base address of the register space. The lower 256 bytes of this space map to the same registers as the 256-byte I/O space pointed to by NAMBAR. The lower 384 bytes are divided as follows:

- 128 bytes for the primary codec (offsets 00–7Fh)
- 128 bytes for the secondary codec (offsets 80–FFh)
- 128 bytes for the tertiary codec (offsets 100h–17Fh).
- 128 bytes of reserved space (offsets 180h–1FFh), returning all 0's.

Bit	Description
31:9	Base Address — R/W. This field provides the lower 32-bits of the 512-byte memory offset to use for decoding the primary, secondary, and tertiary codec's mixer spaces.
8:3	Reserved. Read as 0's.
2:1	Type — RO. Hardwired to 00b to indicate the base address exists in 32-bit address space
0	Resource Type Indicator (RTE) — RO. Hardwired to 0 to indicate a request for memory space.

16.1.13 MBBAR—Bus Master Base Address Register (Audio—D30:F2)

Address Offset:	1C–1Fh	Attribute:	R/W, RO
Default Value:	00000000h	Size:	32 bits
Lockable:	No	Power Well:	Core

This BAR creates 256-bytes of memory space to signify the base address of the bus master memory space. The lower 64-bytes of the space pointed to by this register point to the same registers as the MBBAR.

Bit	Description
31:8	Base Address — R/W. This field provides the I/O offset to use for decoding the PCM In, PCM Out, and Microphone 1 DMA engines.
7:3	Reserved. Read as 0's.
2:1	Type — RO. Hardwired to 00b to indicate the base address exists in 32-bit address space
0	Resource Type Indicator (RTE) — RO. Hardwired to 0 to indicate a request for memory space.

16.1.14 SVID—Subsystem Vendor Identification Register (Audio—D30:F2)

Address Offset:	2C–2Dh	Attribute:	R/WO
Default Value:	0000h	Size:	16 bits
Lockable:	No	Power Well:	Core

The SVID register, in combination with the Subsystem ID register (D30:F2:2Eh), enable the operating environment to distinguish one audio subsystem from the other(s).

This register is implemented as write-once register. Once a value is written to it, the value can be read back. Any subsequent writes will have no effect.

This register is not affected by the D3_{HOT} to D0 transition.

Bit	Description
15:0	Subsystem Vendor ID — R/WO.

16.1.15 SID—Subsystem Identification Register (Audio—D30:F2)

Address Offset:	2E–2Fh	Attribute:	R/WO
Default Value:	0000h	Size:	16 bits
Lockable:	No	Power Well:	Core

The SID register, in combination with the Subsystem Vendor ID register (D30:F2:2Ch) make it possible for the operating environment to distinguish one audio subsystem from the other(s).

This register is implemented as write-once register. Once a value is written to it, the value can be read back. Any subsequent writes will have no effect.

This register is not affected by the D3_{HOT} to D0 transition.

Bit	Description
15:0	Subsystem ID — R/WO.

16.1.16 CAP_PTR—Capabilities Pointer Register (Audio—D30:F2)

Address Offset:	34h	Attribute:	RO
Default Value:	50h	Size:	8 bits
Lockable:	No	Power Well:	Core

This register indicates the offset for the capability pointer.

Bit	Description
7:0	Capabilities Pointer (CAP_PTR) — RO. This field indicates that the first capability pointer offset is offset 50h

16.1.17 INT_LN—Interrupt Line Register (Audio—D30:F2)

Address Offset:	3Ch	Attribute:	R/W
Default Value:	00h	Size:	8 bits
Lockable:	No	Power Well:	Core

This register indicates which PCI interrupt line is used for the AC '97 module interrupt.

Bit	Description
7:0	Interrupt Line (INT_LN) — R/W. This data is not used by the Intel® ICH6. It is used to communicate to software the interrupt line that the interrupt pin is connected to.

16.1.18 INT_PN—Interrupt Pin Register (Audio—D30:F2)

Address Offset:	3Dh	Attribute:	RO
Default Value:	See Description	Size:	8 bits
Lockable:	No	Power Well:	Core

This register indicates which PCI interrupt pin is used for the AC '97 module interrupt. The AC '97 interrupt is internally OR'd to the interrupt controller with the PIRQB# signal.

Bit	Description
7:0	AC '97 Interrupt Routing — RO. This reflects the value of D30IP.AAIP in chipset configuration space.

16.1.19 PCID—Programmable Codec Identification Register (Audio—D30:F2)

Address Offset:	40h	Attribute:	R/W
Default Value:	09h	Size:	8 bits
Lockable:	No	Power Well:	Core

This register is used to specify the ID for the secondary and tertiary codecs for I/O accesses. This register is not affected by the D3_{HOT} to D0 transition. The value in this register must be modified only before any AC '97 codec accesses.

Bit	Description
7:4	Reserved.
3:2	Tertiary Codec ID (TID) — R/W. These bits define the encoded ID that is used to address the tertiary codec I/O space. Bit 1 is the first bit sent and Bit 0 is the second bit sent on ACZ_SDOOUT during slot 0.
1:0	Secondary Codec ID (SCID) — R/W. These two bits define the encoded ID that is used to address the secondary codec I/O space. The two bits are the ID that will be placed on slot 0, bits 0 and 1, upon an I/O access to the secondary codec. Bit 1 is the first bit sent and bit 0 is the second bit sent on ACZ_SDOOUT during slot 0.

16.1.20 CFG—Configuration Register (Audio—D30:F2)

Address Offset:	41h	Attribute:	R/W
Default Value:	00h	Size:	8 bits
Lockable:	No	Power Well:	Core

This register is used to specify the ID for the secondary and tertiary codecs for I/O accesses. This register is not affected by the D3_{HOT} to D0 transition.

Bit	Description
7:1	Reserved—RO.
0	I/O Space Enable (IOSE) — R/W. 0 = Disable. The IOS bit at offset 04h and the I/O space BARs at offset 10h and 14h become read only registers. Additionally, bit 0 of the I/O BARs at offsets 10h and 14h are hardwired to 0 when this bit is 0. This is the default state for the I/O BARs. BIOS must explicitly set this bit to allow a legacy driver to work. 1 = Enable.

16.1.21 PID—PCI Power Management Capability Identification Register (Audio—D30:F2)

Address Offset:	50–51h	Attribute:	RO
Default Value:	0001h	Size:	16 bits
Lockable:	No	Power Well:	Core

Bit	Description
15:8	Next Capability (NEXT) — RO. This field indicates that the next item in the list is at offset 00h.
7:0	Capability ID (CAP) — RO. This field indicates that this pointer is a message signaled interrupt capability

16.1.22 PC—Power Management Capabilities Register (Audio—D30:F2)

Address Offset:	52–53h	Attribute:	RO
Default Value:	C9C2h	Size:	16 bits
Lockable:	No	Power Well:	Core

This register is not affected by the D3_{HOT} to D0 transition.

Bit	Description
15:11	PME Support — RO. This field indicates PME# can be generated from all D states.
10:9	Reserved.
8:6	Auxiliary Current — RO. This field reports 375 mA maximum suspend well current required when in the D3 _{COLD} state.
5	Device Specific Initialization (DSI)—RO. This field indicates that no device-specific initialization is required.
4	Reserved — RO.
3	PME Clock (PMEC) — RO. This field indicates that PCI clock is not required to generate PME#.
2:0	Version (VER) — RO. This field indicates support for <i>Revision 1.1 of the PCI Power Management Specification</i> .

16.1.23 PCS—Power Management Control and Status Register (Audio—D30:F2)

Address Offset:	54–55h	Attribute:	R/W, R/WC
Default Value:	0000h	Size:	16 bits
Lockable:	No	Power Well:	Resume

Bit	Description
15	PME Status (PMES) — R/WC. This bit resides in the resume well. Software clears this bit by writing a 1 to it. 0 = PME# signal Not asserted by AC '97 controller. 1 = This bit is set when the AC '97 controller would normally assert the PME# signal independent of the state of the PME_En bit.
14:9	Reserved — RO.
8	Power Management Event Enable (PMEE) — R/W. 0 = Disable. 1 = Enable. When set, and if corresponding PMES is also set, the AC '97 controller sets the AC97_STS bit in the GPE0_STS register
7:2	Reserved—RO.
1:0	Power State (PS) — R/W. This field is used both to determine the current power state of the AC '97 controller and to set a new power state. The values are: 00 = D0 state 01 = not supported 10 = not supported 11 = D3 _{HOT} state When in the D3 _{HOT} state, the AC '97 controller's configuration space is available, but the I/O and memory spaces are not. Additionally, interrupts are blocked. If software attempts to write a value of 10b or 01b in to this field, the write operation must complete normally; however, the data is discarded and no state change occurs.

16.2 AC '97 Audio I/O Space (D30:F2)

The AC '97 I/O space includes Native Audio Bus Master registers and Native Mixer registers. For the ICH6, the offsets are important as they will determine bits 1:0 of the TAG field (codec ID).

Audio Mixer I/O space can be accessed as a 16-bit field only since the data packet length on AC-link is a word. Any S/W access to the codec will be done as a 16-bit access starting from the first active byte. In case no byte enables are active, the access will be done at the first word of the qWord that contains the address of this request.

Table 16-2. Intel® ICH6 Audio Mixer Register Configuration

Primary Offset (Codec ID =00)	Secondary Offset (Codec ID =01)	Tertiary Offset (Codec ID =10)	NAMBAR Exposed Registers (D30:F2)
00h	80h	100h	Reset
02h	82h	102h	Master Volume
04h	84h	104h	Aux Out Volume
06h	86h	106h	Mono Volume
08h	88h	108h	Master Tone (R & L)
0Ah	8Ah	10Ah	PC_BEEP Volume
0Ch	8Ch	10Ch	Phone Volume
0Eh	8Eh	10Eh	Mic Volume
10h	90h	110h	Line In Volume
12h	92h	112h	CD Volume
14h	94h	114h	Video Volume
16h	96h	116h	Aux In Volume
18h	98h	118h	PCM Out Volume
1Ah	9Ah	11Ah	Record Select
1Ch	9Ch	11Ch	Record Gain
1Eh	9Eh	11Eh	Record Gain Mic
20h	A0h	120h	General Purpose
22h	A2h	122h	3D Control
24h	A4h	124h	AC '97 RESERVED
26h	A6h	126h	Powerdown Ctrl/Stat
28h	A8h	128h	Extended Audio
2Ah	AAh	12Ah	Extended Audio Ctrl/Stat
2Ch	ACh	12Ch	PCM Front DAC Rate
2Eh	A Eh	12Eh	PCM Surround DAC Rate
30h	B0h	130h	PCM LFE DAC Rate
32h	B2h	132h	PCM LR ADC Rate
34h	B4h	134h	MIC ADC Rate
36h	B6h	136h	6Ch Vol: C, LFE
38h	B8h	138h	6Ch Vol: L, R Surround
3Ah	BAh	13Ah	S/PDIF Control
3C–56h	BC–D6h	13C–156h	Intel RESERVED
58h	D8h	158h	AC '97 Reserved

Table 16-2. Intel® ICH6 Audio Mixer Register Configuration

Primary Offset (Codec ID =00)	Secondary Offset (Codec ID =01)	Tertiary Offset (Codec ID =10)	NAMBAR Exposed Registers (D30:F2)
5Ah	DAh	15Ah	Vendor Reserved
7Ch	FCh	17Ch	Vendor ID1
7Eh	FEh	17Eh	Vendor ID2

NOTE:

1. Software should not try to access reserved registers
2. Primary Codec ID cannot be changed. Secondary codec ID can be changed via bits 1:0 of configuration register 40h. Tertiary codec ID can be changed via bits 3:2 of configuration register 40h.
3. The tertiary offset is only available through the memory space defined by the MMBAR register.

The Bus Master registers are located from offset + 00h to offset + 51h and reside in the AC '97 controller. Accesses to these registers do **not** cause the cycle to be forwarded over the AC-link to the codec. S/W could access these registers as bytes, word, DWord or qword quantities, but reads must not cross DWord boundaries.

In the case of the split codec implementation accesses to the different codecs are differentiated by the controller by using address offsets 00h–7Fh for the primary codec, address offsets 80h–FFh for the secondary codec and address offsets 100h–17Fh for the tertiary codec.

The Global Control (GLOB_CNT) (D30:F2:2Ch) and Global Status (GLOB_STA) (D30:F2:30h) registers are aliased to the same global registers in the audio and modem I/O space. Therefore a read/write to these registers in either audio or modem I/O space affects the same physical register.

Bus Mastering registers exist in I/O space and reside in the AC '97 controller. The six channels, PCM in, PCM in 2, PCM out, Mic in, Mic 2, and S/PDIF out, each have their own set of Bus Mastering registers. The following register descriptions apply to all six channels. The register definition section titles use a generic “x_” in front of the register to indicate that the register applies to all six channels. The naming prefix convention used in Table 16-3 and in the register description I/O address is as follows:

PI = PCM in channel
 PO = PCM out channel
 MC = Mic in channel
 MC2 = Mic 2 channel
 PI2 = PCM in 2 channel
 SP = S/PDIF out channel.

Table 16-3. Native Audio Bus Master Control Registers (Sheet 1 of 2)

Offset	Mnemonic	Name	Default	Access
00h	PI_BDBAR	PCM In Buffer Descriptor list Base Address	00000000h	R/W
04h	PI_CIV	PCM In Current Index Value	00h	RO
05h	PI_LVI	PCM In Last Valid Index	00h	R/W
06h	PI_SR	PCM In Status	0001h	R/WC, RO
08h	PI_PICB	PCM In Position in Current Buffer	0000h	RO
0Ah	PI_PIV	PCM In Prefetched Index Value	00h	RO
0Bh	PI_CR	PCM In Control	00h	R/W, R/W (special)
10h	PO_BDBAR	PCM Out Buffer Descriptor list Base Address	00000000h	R/W

Table 16-3. Native Audio Bus Master Control Registers (Sheet 2 of 2)

Offset	Mnemonic	Name	Default	Access
14h	PO_CIV	PCM Out Current Index Value	00h	RO
15h	PO_LVI	PCM Out Last Valid Index	00h	R/W
16h	PO_SR	PCM Out Status	0001h	R/WC, RO
18h	PO_PICB	PCM In Position In Current Buffer	0000h	RO
1Ah	PO_PIV	PCM Out Prefetched Index Value	00h	RO
1Bh	PO_CR	PCM Out Control	00h	R/W, R/W (special)
20h	MC_BDBAR	Mic. In Buffer Descriptor List Base Address	00000000h	R/W
24h	MC_CIV	Mic. In Current Index Value	00h	RO
25h	MC_LVI	Mic. In Last Valid Index	00h	R/W
26h	MC_SR	Mic. In Status	0001h	R/WC, RO
28h	MC_PICB	Mic. In Position In Current Buffer	0000h	RO
2Ah	MC_PIV	Mic. In Prefetched Index Value	00h	RO
2Bh	MC_CR	Mic. In Control	00h	R/W, R/W (special)
2Ch	GLOB_CNT	Global Control	00000000h	R/W, R/W (special)
30h	GLOB_STA	Global Status	See register description	R/W, R/WC, RO
34h	CAS	Codec Access Semaphore	00h	R/W (special)
40h	MC2_BDBAR	Mic. 2 Buffer Descriptor List Base Address	00000000h	R/W
44h	MC2_CIV	Mic. 2 Current Index Value	00h	RO
45h	MC2_LVI	Mic. 2 Last Valid Index	00h	R/W
46h	MC2_SR	Mic. 2 Status	0001h	RO, R/WC
48h	MC2_PICB	Mic 2 Position In Current Buffer	0000h	RO
4Ah	MC2_PIV	Mic. 2 Prefetched Index Value	00h	RO
4Bh	MC2_CR	Mic. 2 Control	00h	R/W, R/W (special)
50h	PI2_BDBAR	PCM In 2 Buffer Descriptor List Base Address	00000000h	R/W
54h	PI2_CIV	PCM In 2 Current Index Value	00h	RO
55h	PI2_LVI	PCM In 2 Last Valid Index	00h	R/W
56h	PI2_SR	PCM In 2 Status	0001h	R/WC, RO
58h	PI2_PICB	PCM In 2 Position in Current Buffer	0000h	RO
5Ah	PI2_PIV	PCM In 2 Prefetched Index Value	00h	RO
5Bh	PI2_CR	PCM In 2 Control	00h	R/W, R/W (special)
60h	SPBAR	S/PDIF Buffer Descriptor List Base Address	00000000h	R/W
64h	SPCIV	S/PDIF Current Index Value	00h	RO
65h	SPLVI	S/PDIF Last Valid Index	00h	R/W
66h	SPSR	S/PDIF Status	0001h	R/WC, RO
68h	SPPICB	S/PDIF Position In Current Buffer	0000h	RO
6Ah	SPPIV	S/PDIF Prefetched Index Value	00h	RO
6Bh	SPCR	S/PDIF Control	00h	R/W, R/W (special)
80h	SDM	SData_IN Map	00h	R/W, RO

Note: Internal reset as a result of D3_{HOT} to D0 transition will reset all the core well registers except the registers shared with the AC '97 Modem (GCR, GSR, CASR). All resume well registers will not be reset by the D3_{HOT} to D0 transition.

Core well registers and bits **not** reset by the D3_{HOT} to D0 transition:

- offset 2Ch–2Fh – bits 6:0 Global Control (GLOB_CNT)
- offset 30h–33h – bits [29,15,11:10,0] Global Status (GLOB_STA)
- offset 34h – Codec Access Semaphore Register (CAS)

Resume well registers and bits **will not** be reset by the D3_{HOT} to D0 transition:

- offset 30h–33h – bits [17:16] Global Status (GLOB_STA)

16.2.1 x_BDBAR—Buffer Descriptor Base Address Register (Audio—D30:F2)

I/O Address:	NABMBAR + 00h (PIBDBAR), NABMBAR + 10h (POBDBAR), NABMBAR + 20h (MCBDBAR), MBBAR + 40h (MC2BDBAR), MBBAR + 50h (PI2BDBAR), MBBAR + 60h (SPBAR)	Attribute:	R/W
Default Value:	00000000h	Size:	32 bits
Lockable:	No	Power Well:	Core

Software can read the register at offset 00h by performing a single 32-bit read from address offset 00h. Reads across DWord boundaries are not supported.

Bit	Description
31:3	Buffer Descriptor Base Address[31:3] — R/W. These bits represent address bits 31:3. The data should be aligned on 8-byte boundaries. Each buffer descriptor is 8 bytes long and the list can contain a maximum of 32 entries.
2:0	Hardwired to 0.

16.2.2 x_CIV—Current Index Value Register (Audio—D30:F2)

I/O Address:	NABMBAR + 04h (PICIV), NABMBAR + 14h (POCIV), NABMBAR + 24h (MCCIV) MBBAR + 44h (MC2CIV) MBBAR + 54h (PI2CIV) MBBAR + 64h (SPCIV)	Attribute:	RO
Default Value:	00h	Size:	8 bits
Lockable:	No	Power Well:	Core

Software can read the registers at offsets 04h, 05h and 06h simultaneously by performing a single, 32-bit read from address offset 04h. Software can also read this register individually by doing a single, 8-bit read to offset 04h.

Bit	Description
7:5	Hardwired to 0
4:0	Current Index Value [4:0] — RO. These bits represent which buffer descriptor within the list of 32 descriptors is currently being processed. As each descriptor is processed, this value is incremented. The value rolls over after it reaches 31.

NOTE: Reads across DWord boundaries are not supported.

16.2.3 x_LVI—Last Valid Index Register (Audio—D30:F2)

I/O Address:	NABMBAR + 05h (PILVI), NABMBAR + 15h (POLVI), NABMBAR + 25h (MCLVI) MBBAR + 45h (MC2LVI) MBBAR + 55h (PI2LVI) MBBAR + 65h (SPLVI)	Attribute:	R/W
Default Value:	00h	Size:	8 bits
Lockable:	No	Power Well:	Core

Software can read the registers at offsets 04h, 05h and 06h simultaneously by performing a single, 32-bit read from address offset 04h. Software can also read this register individually by doing a single, 8-bit read to offset 05h.

Bit	Description
7:5	Hardwired to 0.
4:0	Last Valid Index [4:0] — R/W. This value represents the last valid descriptor in the list. This value is updated by the software each time it prepares a new buffer and adds it to the list.

NOTE: Reads across DWord boundaries are not supported.

16.2.4 x_SR—Status Register (Audio—D30:F2)

I/O Address:	NABMBAR + 06h (PISR), NABMBAR + 16h (POSR), NABMBAR + 26h (MCSR) MBBAR + 46h (MC2SR) MBBAR + 56h (PI2SR) MBBAR + 66h (SPSR)	Attribute:	R/WC, RO
Default Value:	0001h	Size:	16 bits
Lockable:	No	Power Well:	Core

Software can read the registers at offsets 04h, 05h and 06h simultaneously by performing a single, 32-bit read from address offset 04h. Software can also read this register individually by doing a single, 16-bit read to offset 06h. Reads across DWord boundaries are not supported.

Bit	Description
15:5	Reserved.
4	<p>FIFO Error (FIFOE) — R/WC. Software clears this bit by writing a 1 to it.</p> <p>0 = No FIFO error. 1 = FIFO error occurs.</p> <p>PISR Register: FIFO error indicates a FIFO overrun. The FIFO pointers don't increment, the incoming data is not written into the FIFO, thus is lost.</p> <p>POSR Register: FIFO error indicates a FIFO underrun. The sample transmitted in this case should be the last valid sample.</p> <p>The ICH6 will set the FIFOE bit if the under-run or overrun occurs when there are more valid buffers to process.</p>
3	<p>Buffer Completion Interrupt Status (BCIS) — R/WC.</p> <p>0 = Software clears this bit by writing a 1 to it. 1 = Set by the hardware after the last sample of a buffer has been processed, AND if the Interrupt on Completion (IOC) bit is set in the command byte of the buffer descriptor. It remains active until cleared by software.</p>
2	<p>Last Valid Buffer Completion Interrupt (LVBCI) — R/WC.</p> <p>0 = Software clears this bit by writing a 1 to it. 1 = Last valid buffer has been processed. It remains active until cleared by software. This bit indicates the occurrence of the event signified by the last valid buffer being processed. Thus this is an event status bit that can be cleared by software once this event has been recognized. This event will cause an interrupt if the enable bit (D30:F2:NABMBAR + 0Bh, bit 2) in the Control Register is set. The interrupt is cleared when the software clears this bit.</p> <p>In the case of <i>Transmits</i> (PCM out, Modem out) this bit is set, after the last valid buffer has been fetched (not after transmitting it). While in the case of <i>Receives</i>, this bit is set after the data for the last buffer has been written to memory.</p>
1	<p>Current Equals Last Valid (CELV) — RO.</p> <p>0 = Cleared by hardware when controller exists state (i.e., until a new value is written to the LVI register.) 1 = Current Index is equal to the value in the Last Valid Index Register (D30:F2:NABMBAR + 05h), and the buffer pointed to by the CIV has been processed (i.e., after the last valid buffer has been processed). This bit is very similar to bit 2, except this bit reflects the state rather than the event. This bit reflects the state of the controller, and remains set until the controller exits this state.</p>
0	<p>DMA Controller Halted (DCH) — RO.</p> <p>0 = Running. 1 = Halted. This could happen because of the Start/Stop bit being cleared and the DMA engines are idle, or it could happen once the controller has processed the last valid buffer.</p>

16.2.5 x_PICB—Position In Current Buffer Register (Audio—D30:F2)

I/O Address:	NABMBAR + 08h (PIPICB), NABMBAR + 18h (POPICB), NABMBAR + 28h (MCPICB) MBBAR + 48h (MC2PICB) MBBAR + 58h (PI2PICB) MBBAR + 68h (SPPICB)	Attribute:	RO
Default Value:	0000h	Size:	16 bits
Lockable:	No	Power Well:	Core

Software can read the registers at the offsets 08h, 0Ah, and 0Bh by performing a 32-bit read from the address offset 08h. Software can also read this register individually by doing a single, 16-bit read to offset 08h. Reads across DWord boundaries are not supported.

Bit	Description
15:0	Position In Current Buffer [15:0] — RO. These bits represent the number of samples left to be processed in the current buffer. Once again, this means, the number of samples not yet read from memory (in the case of reads from memory) or not yet written to memory (in the case of writes to memory), irrespective of the number of samples that have been transmitted/received across AC-link.

16.2.6 x_PIV—Prefetched Index Value Register (Audio—D30:F2)

I/O Address:	NABMBAR + 0Ah (PIPIV), NABMBAR + 1Ah (POPIV), NABMBAR + 2Ah (MCPIV) MBBAR + 4Ah (MC2PIV) MBBAR + 5Ah (PI2PIV) MBBAR + 6Ah (SPPIV)	Attribute:	RO
Default Value:	00h	Size:	8 bits
Lockable:	No	Power Well:	Core

Software can read the registers at the offsets 08h, 0Ah, and 0Bh by performing a 32-bit read from the address offset 08h. Software can also read this register individually by doing a single, 8-bit read to offset 0Ah. Reads across DWord boundaries are not supported

Bit	Description
7:5	Hardwired to 0.
4:0	Prefetched Index Value [4:0] — RO. These bits represent which buffer descriptor in the list has been prefetched. The bits in this register are also modulo 32 and roll over after they reach 31.

16.2.7 x_CR—Control Register (Audio—D30:F2)

I/O Address:	NABMBAR + 0Bh (PICR), NABMBAR + 1Bh (POCR), NABMBAR + 2Bh (MCCR) MBBAR + 4Bh (MC2CR) MBBAR + 5Bh (PI2CR) MBBAR + 6Bh (SPCR)	Attribute:	R/W, R/W (special)
Default Value:	00h	Size:	8 bits
Lockable:	No	Power Well:	Core

Software can read the registers at the offsets 08h, 0Ah, and 0Bh by performing a 32-bit read from the address offset 08h. Software can also read this register individually by doing a single, 8-bit read to offset 0Bh. Reads across DWord boundaries are not supported.

Bit	Description
7:5	Reserved.
4	Interrupt on Completion Enable (IOCE) — R/W. This bit controls whether or not an interrupt occurs when a buffer completes with the IOC bit set in its descriptor. 0 = Disable. Interrupt will not occur. 1 = Enable.
3	FIFO Error Interrupt Enable (FEIE) — R/W. This bit controls whether the occurrence of a FIFO error will cause an interrupt or not. 0 = Disable. Bit 4 in the Status register will be set, but the interrupt will not occur. 1 = Enable. Interrupt will occur.
2	Last Valid Buffer Interrupt Enable (LVBIE) — R/W. This bit controls whether the completion of the last valid buffer will cause an interrupt or not. 0 = Disable. Bit 2 in the Status register will still be set, but the interrupt will not occur. 1 = Enable.
1	Reset Registers (RR) — R/W (special). 0 = Removes reset condition. 1 = Contents of all Bus master related registers to be reset, except the interrupt enable bits (bit 4,3,2 of this register). Software needs to set this bit but need not clear it since the bit is self clearing. This bit must be set only when the Run/Pause bit (D30:F2:2Bh, bit 0) is cleared. Setting it when the Run bit is set will cause undefined consequences.
0	Run/Pause Bus Master (RPBM) — R/W. 0 = Pause bus master operation. This results in all state information being retained (i.e., master mode operation can be stopped and then resumed). 1 = Run. Bus master operation starts.

16.2.8 GLOB_CNT—Global Control Register (Audio—D30:F2)

I/O Address:	NABMBAR + 2Ch	Attribute:	R/W, R/W (special)
Default Value:	00000000h	Size:	32 bits
Lockable:	No	Power Well:	Core

Bit	Description
31:30	<p>S/PDIF Slot Map (SSM) — R/W. If the run/pause bus master bit (bit 0 of offset 2Bh) is set, then the value in these bits indicate which slots S/PDIF data is transmitted on. Software must ensure that the programming here does not conflict with the PCM channels being used. If there is a conflict, unpredictable behavior will result — the hardware will not check for a conflict.</p> <p>00 = Reserved 01 = Slots 7 and 8 10 = Slots 6 and 9 11 = Slots 10 and 11</p>
29:24	Reserved.
23:22	<p>PCM Out Mode (POM) — R/W. Enables the PCM out channel to use 16- or 20-bit audio on PCM out. This does not affect the microphone of S/PDIF DMA. When greater than 16-bit audio is used, the data structures are aligned as 32-bits per sample, with the highest order bits representing the data, and the lower order bits as don't care.</p> <p>00 = 16 bit audio (default) 01 = 20 bit audio 10 = Reserved. If set, indeterminate behavior will result. 11 = Reserved. If set, indeterminate behavior will result.</p>
21:20	<p>PCM 4/6 Enable — R/W. This field configures PCM Output for 2-, 4- or 6-channel mode.</p> <p>00 = 2-channel mode (default) 01 = 4-channel mode 10 = 6-channel mode 11 = Reserved</p>
19:7	Reserved.
6	<p>ACZ_SDIN2 Interrupt Enable — R/W.</p> <p>0 = Disable. 1 = Enable an interrupt to occur when the codec on the ACZ_SDIN2 causes a resume event on the AC-link.</p> <p>NOTE: This bit is not affected by AC '97 Audio Function D3_{HOT} to D0 reset.</p>
5	<p>ACZ_SDIN1 Interrupt Enable — R/W.</p> <p>0 = Disable. 1 = Enable an interrupt to occur when the codec on the ACZ_SDIN1 causes a resume event on the AC-link.</p> <p>NOTE: This bit is not affected by AC '97 Audio Function D3_{HOT} to D0 reset.</p>
4	<p>ACZ_SDIN0 Interrupt Enable — R/W.</p> <p>0 = Disable. 1 = Enable an interrupt to occur when the codec on ACZ_SDIN0 causes a resume event on the AC-link.</p> <p>NOTE: This bit is not affected by AC '97 Audio Function D3_{HOT} to D0 reset.</p>
3	<p>AC-LINK Shut Off (LSO) — R/W.</p> <p>0 = Normal operation. 1 = Controller disables all outputs which will be pulled low by internal pull down resistors.</p> <p>NOTE: This bit is not affected by AC '97 Audio Function D3_{HOT} to D0 reset.</p>

Bit	Description
2	<p>AC '97 Warm Reset — R/W (special).</p> <p>0 = Normal operation. 1 = Writing a 1 to this bit causes a warm reset to occur on the AC-link. The warm reset will awaken a suspended codec without clearing its internal registers. If software attempts to perform a warm reset while bit_clk is running, the write will be ignored and the bit will not change. This bit is self-clearing (it remains set until the reset completes and bit_clk is seen on the AC-link, after which it clears itself).</p> <p>NOTE: This bit is not affected by AC '97 Audio Function D3_{HOT} to D0 reset.</p>
1	<p>AC '97 Cold Reset# — R/W.</p> <p>0 = Writing a 0 to this bit causes a cold reset to occur throughout the AC '97 circuitry. All data in the controller and the codec will be lost. Software needs to clear this bit no sooner than the minimum number of ms have elapsed. 1 = This bit defaults to 0 and hence after reset, the driver needs to set this bit to a 1. The value of this bit is retained after suspends; hence, if this bit is set to a 1 prior to suspending, a cold reset is not generated automatically upon resuming.</p> <p>Note: This bit is in the core well and is not affected by AC '97 Audio Function D3_{HOT} to D0 reset.</p>
0	<p>GPI Interrupt Enable (GIE) — R/W. This bit controls whether the change in status of any GPI causes an interrupt.</p> <p>0 = Bit 0 of the Global Status register is set, but no interrupt is generated. 1 = The change on value of a GPI causes an interrupt and sets bit 0 of the Global Status register.</p> <p>NOTE: This bit is not affected by AC '97 Audio Function D3_{HOT} to D0 reset.</p>

NOTE: Reads across DWord boundaries are not supported.

16.2.9 GLOB_STA—Global Status Register (Audio—D30:F2)

I/O Address: NABMBAR + 30h Attribute: RO, R/W, R/WC
 Default Value: 00x0xxx01110000000000xxxx00xxxbSize: 32 bits
 Lockable: No Power Well: Core

Bit	Description
31:30	Reserved.
29	ACZ_SDIN2 Resume Interrupt (S2RI) — R/WC. This bit indicates a resume event occurred on ACZ_SDIN2. Software clears this bit by writing a 1 to it. 0 = Resume event did Not occur. 1 = Resume event occurred. This bit is not affected by D3 _{HOT} to D0 Reset.
28	ACZ_SDIN2 Codec Ready (S2CR) — RO. Reflects the state of the codec ready bit on ACZ_SDIN2. Bus masters ignore the condition of the codec ready bits, so software must check this bit before starting the bus masters. Once the codec is “ready”, it must never go “not ready” spontaneously. 0 = Not Ready. 1 = Ready.
27	Bit Clock Stopped (BCS) — RO. This bit indicates that the bit clock is not running. 0 = Transition is found on BIT_CLK. 1 = ICH6 detected that there has been no transition on BIT_CLK for four consecutive PCI clocks.
26	S/PDIF Interrupt (SPINT) — RO. 0 = When the specific status bit is cleared, this bit will be cleared. 1 = S/PDIF out channel interrupt status bits have been set.
25	PCM In 2 Interrupt (P2INT) — RO. 0 = When the specific status bit is cleared, this bit will be cleared. 1 = One of the PCM In 2 channel status bits have been set.
24	Microphone 2 In Interrupt (M2INT) — RO. 0 = When the specific status bit is cleared, this bit will be cleared. 1 = One of the Mic in channel interrupts status bits has been set.
23:22	Sample Capabilities — RO. This field indicates the capability to support more greater than 16-bit audio. 00 = Reserved 01 = 16 and 20-bit Audio supported (ICH6 value) 10 = Reserved 11 = Reserved
21:20	Multichannel Capabilities — RO. This field indicates the capability to support more 4 and 6 channels on PCM Out.
19:18	Reserved.
17	MD3 — R/W. Power down semaphore for Modem. This bit exists in the suspend well and maintains context across power states (except G3). The bit has no hardware function. It is used by software in conjunction with the AD3 bit to coordinate the entry of the two codecs into D3 state. This bit is not affected by D3 _{HOT} to D0 Reset.
16	AD3 — R/W. Power down semaphore for Audio. This bit exists in the suspend well and maintains context across power states (except G3). The bit has no hardware function. It is used by software in conjunction with the MD3 bit to coordinate the entry of the two codecs into D3 state. This bit is not affected by D3 _{HOT} to D0 Reset.

Bit	Description
15	Read Completion Status (RCS) — R/WC. This bit indicates the status of codec read completions. 0 = A codec read completes normally. 1 = A codec read results in a time-out. The bit remains set until being cleared by software writing a 1 to the bit location. This bit is not affected by D3 _{HOT} to D0 Reset.
14	Bit 3 of Slot 12 — RO. Display bit 3 of the most recent slot 12.
13	Bit 2 of Slot 12 — RO. Display bit 2 of the most recent slot 12.
12	Bit 1 of slot 12 — RO. Display bit 1 of the most recent slot 12.
11	ACZ_SDIN1 Resume Interrupt (S1R1) — R/WC. This bit indicates that a resume event occurred on ACZ_SDIN1. Software clears this bit by writing a 1 to it. 0 = Resume event did Not occur 1 = Resume event occurred. This bit is not affected by D3 _{HOT} to D0 Reset.
10	ACZ_SDIN0 Resume Interrupt (S0R1) — R/WC. This bit indicates that a resume event occurred on ACZ_SDIN0. Software clears this bit by writing a 1 to it. 0 = Resume event did Not occur 1 = Resume event occurred. This bit is not affected by D3 _{HOT} to D0 Reset.
9	ACZ_SDIN1 Codec Ready (S1CR) — RO. Reflects the state of the codec ready bit in ACZ_SDIN1. Bus masters ignore the condition of the codec ready bits, so software must check this bit before starting the bus masters. Once the codec is “ready”, it must never go “not ready” spontaneously. 0 = Not Ready. 1 = Ready.
8	ACZ_SDIN0 Codec Ready (S0CR) — RO. Reflects the state of the codec ready bit in ACZ_SDIN0. Bus masters ignore the condition of the codec ready bits, so software must check this bit before starting the bus masters. Once the codec is “ready”, it must never go “not ready” spontaneously. 0 = Not Ready. 1 = Ready.
7	Microphone In Interrupt (MINT) — RO. 0 = When the specific status bit is cleared, this bit will be cleared. 1 = One of the Mic in channel interrupts status bits has been set.
6	PCM Out Interrupt (POINT) — RO. 0 = When the specific status bit is cleared, this bit will be cleared. 1 = One of the PCM out channel interrupts status bits has been set.
5	PCM In Interrupt (PIINT) — RO. 0 = When the specific status bit is cleared, this bit will be cleared. 1 = One of the PCM in channel interrupts status bits has been set.
4:3	Reserved
2	Modem Out Interrupt (MOINT) — RO. 0 = When the specific status bit is cleared, this bit will be cleared. 1 = One of the modem out channel interrupts status bits has been set.
1	Modem In Interrupt (MIINT) — RO. 0 = When the specific status bit is cleared, this bit will be cleared. 1 = One of the modem in channel interrupts status bits has been set.
0	GPI Status Change Interrupt (GSCI) — R/WC. 0 = Software clears this bit by writing a 1 to it. 1 = This bit reflects the state of bit 0 in slot 12, and is set when bit 0 of slot 12 is set. This indicates that one of the GPI's changed state, and that the new values are available in slot 12. This bit is not affected by AC '97 Audio Function D3 _{HOT} to D0 Reset.

NOTE: Reads across DWord boundaries are not supported.

16.2.10 CAS—Codec Access Semaphore Register (Audio—D30:F2)

I/O Address:	NABMBAR + 34h	Attribute:	R/W (special)
Default Value:	00h	Size:	8 bits
Lockable:	No	Power Well:	Core

Bit	Description
7:1	Reserved.
0	Codec Access Semaphore (CAS) — R/W (special). This bit is read by software to check whether a codec access is currently in progress. 0 = No access in progress. 1 = The act of reading this register sets this bit to 1. The driver that read this bit can then perform an I/O access. Once the access is completed, hardware automatically clears this bit.

NOTE: Reads across DWord boundaries are not supported.

16.2.11 SDM—SDATA_IN Map Register (Audio—D30:F2)

I/O Address:	NABMBAR + 80h	Attribute:	R/W, RO
Default Value:	00h	Size:	8 bits
Lockable:	No	Power Well:	Core

Bit	Description
7:6	PCM In 2, Microphone In 2 Data In Line (DI2L) — R/W. When the SE bit is set, these bits indicates which ACZ_SDIN line should be used by the hardware for decoding the input slots for PCM In 2 and Microphone In 2. When the SE bit is cleared, the value of these bits are irrelevant, and PCM In 2 and Mic In 2 DMA engines are not available. 00 = ACZ_SDIN0 01 = ACZ_SDIN1 10 = ACZ_SDIN2 11 = Reserved
5:4	PCM In 1, Microphone In 1 Data In Line (DI1L) — R/W. When the SE bit is set, these bits indicates which ACZ_SDIN line should be used by the hardware for decoding the input slots for PCM In 1 and Microphone In 1. When the SE bit is cleared, the value of these bits are irrelevant, and the PCM In 1 and Mic In 1 engines use the OR'd ACZ_SDIN lines. 00 = ACZ_SDIN0 01 = ACZ_SDIN1 10 = ACZ_SDIN2 11 = Reserved
3	Steer Enable (SE) — R/W. When set, the ACZ_SDIN lines are treated separately and not OR'd together before being sent to the DMA engines. When cleared, the ACZ_SDIN lines are OR'd together, and the "Microphone In 2" and "PCM In 2" DMA engines are not available.
2	Reserved — RO.
1:0	Last Codec Read Data Input (LDI) — RO. When a codec register is read, this indicates which ACZ_SDIN the read data returned on. Software can use this to determine how the codecs are mapped. The values are: 00 = ACZ_SDIN0 01 = ACZ_SDIN1 10 = ACZ_SDIN2 11 = Reserved

NOTE: Reads across DWord boundaries are not supported.

§



17 AC '97 Modem Controller Registers (D30:F3)

17.1 AC '97 Modem PCI Configuration Space (D30:F3)

Note: Registers that are not shown should be treated as Reserved.

Table 17-1. AC '97 Modem PCI Register Address Map (Modem—D30:F3)

Offset	Mnemonic	Register	Default	Access
00–01h	VID	Vendor Identification	8086	RO
02–03h	DID	Device Identification	266Dh	RO
04–05h	PCICMD	PCI Command	0000h	R/W, RO
06–07h	PCISTS	PCI Status	0290h	R/WC, RO
08h	RID	Revision Identification	See register description	RO
09h	PI	Programming Interface	00h	RO
0Ah	SCC	Sub Class Code	03h	RO
0Bh	BCC	Base Class Code	07h	RO
0Eh	HEADTYP	Header Type	00h	RO
10–13h	MMBAR	Modem Mixer Base Address	00000001h	R/W, RO
14–17h	MBAR	Modem Base Address	00000001h	R/W, RO
2C–2Dh	SVID	Subsystem Vendor Identification	0000h	R/WO
2E–2Fh	SID	Subsystem Identification	0000h	R/WO
34h	CAP_PTR	Capabilities Pointer	50h	RO
3Ch	INT_LN	Interrupt Line	00h	R/W
3Dh	INT_PN	Interrupt Pin	See register description	RO
50–51h	PID	PCI Power Management Capability ID	0001h	RO
52–53h	PC	Power Management Capabilities	C9C2h	RO
54–55h	PCS	Power Management Control and Status	0000h	R/W, R/WC

Note: Internal reset as a result of D3_{HOT} to D0 transition will reset all the core well registers except the following BIOS programmed registers as BIOS may not be invoked following the D3-to-D0 transition. All resume well registers will not be reset by the D3_{HOT} to D0 transition.

Core well registers **not** reset by the D3_{HOT} to D0 transition:

- offset 2Ch–2Dh – Subsystem Vendor ID (SVID)
- offset 2Eh–2Fh – Subsystem ID (SID)

Resume well registers **will not** be reset by the D3_{HOT} to D0 transition:

- offset 54h–55h – Power Management Control and Status (PCS)

17.1.1 VID—Vendor Identification Register (Modem—D30:F3)

Address Offset:	00–01h	Attribute:	RO
Default Value:	8086	Size:	16 Bits
Lockable:	No	Power Well:	Core

Bit	Description
15:0	Vendor ID.

17.1.2 DID—Device Identification Register (Modem—D30:F3)

Address Offset:	02–03h	Attribute:	RO
Default Value:	266Dh	Size:	16 Bits
Lockable:	No	Power Well:	Core

Bit	Description
15:0	Device ID.

17.1.3 PCICMD—PCI Command Register (Modem—D30:F3)

Address Offset:	04–05h	Attribute:	R/W, RO
Default Value:	0000h	Size:	16 bits
Lockable:	No	Power Well:	Core

PCICMD is a 16-bit control register. Refer to the *PCI Local Bus Specification* for complete details on each bit.

Bit	Description
15:11	Reserved. Read 0.
10	Interrupt Disable (ID) — R/W. 0 = The INTx# signals may be asserted and MSIs may be generated. 1 = The AC '97 controller's INTx# signal will be de-asserted and it may not generate MSIs.
9	Fast Back to Back Enable (FBE) — RO. Not implemented. Hardwired to 0.
8	SERR# Enable (SERR_EN) — RO. Not implemented. Hardwired to 0.
7	Wait Cycle Control (WCC) — RO. Not implemented. Hardwired to 0.
6	Parity Error Response (PER) — RO. Not implemented. Hardwired to 0.
5	VGA Palette Snoop (VPS) — RO. Not implemented. Hardwired to 0.
4	Memory Write and Invalidate Enable (MWIE) — RO. Not implemented. Hardwired to 0.
3	Special Cycle Enable (SCE) — RO. Not implemented. Hardwired to 0.
2	Bus Master Enable (BME) — R/W. This bit controls standard PCI bus mastering capabilities. 0 = Disable 1 = Enable
1	Memory Space Enable (MSE) — RO. Hardwired to 0, AC '97 does not respond to memory accesses.
0	I/O Space Enable (IOSE) — R/W. This bit controls access to the I/O space registers. 0 = Disable access. (default = 0). 1 = Enable access to I/O space. The Native PCI Mode Base Address register should be programmed prior to setting this bit.

17.1.4 PCISTS—PCI Status Register (Modem—D30:F3)

Address Offset:	06–07h	Attribute:	R/WC, RO
Default Value:	0290h	Size:	16 bits
Lockable:	No	Power Well:	Core

PCISTA is a 16-bit status register. Refer to the *PCI Local Bus Specification* for complete details on each bit.

Note: For the writable bits, software must write a 1 to clear bits that are set. Writing a 0 to the bit has no effect.

Bit	Description
15	Detected Parity Error (DPE) — RO. Not implemented. Hardwired to 0.
14	Signaled System Error (SSE) —RO. Not implemented. Hardwired to 0.
13	Master Abort Status (MAS) — R/WC. 0 = Master abort Not generated by bus master AC '97 function. 1 = Bus Master AC '97 interface function, as a master, generates a master abort.
12	Reserved. Read as 0.
11	Signaled Target Abort (STA) — RO. Not implemented. Hardwired to 0.
10:9	DEVSEL# Timing Status (DEV_STS) — RO. This 2-bit field reflects the ICH6's DEVSEL# timing parameter. These read only bits indicate the ICH6's DEVSEL# timing when performing a positive decode.
8	Data Parity Error Detected (DPED) — RO. Not implemented. Hardwired to 0.
7	Fast Back to Back Capable (FB2BC) — RO. Hardwired to 1. This bit indicates that the ICH6 as a target is capable of fast back-to-back transactions.
6	User Definable Features (UDF) — RO. Not implemented. Hardwired to 0.
5	66 MHz Capable (66MHZ_CAP) — RO. Hardwired to 0.
4	Capabilities List (CAP_LIST) — RO. Indicates that the controller contains a capabilities pointer list. The first item is pointed to by looking at configuration offset 34h.
3	Interrupt Status (INTS) — RO. 0 = This bit is 0 after the interrupt is cleared. 1 = This bit is 1 when the INTx# is asserted.
2:0	Reserved

17.1.5 RID—Revision Identification Register (Modem—D30:F3)

Address Offset: 08h Attribute: RO
 Default Value: See bit description Size: 8 Bits
 Lockable: No Power Well: Core

Bit	Description
7:0	Revision ID — RO. Refer to the <i>Intel® I/O Controller Hub 6 (ICH6) Family Specification Update</i> for the value of the Revision ID Register

17.1.6 PI—Programming Interface Register (Modem—D30:F3)

Address Offset: 09h Attribute: RO
 Default Value: 00h Size: 8 bits
 Lockable: No Power Well: Core

Bit	Description
7:0	Programming Interface — RO.

17.1.7 SCC—Sub Class Code Register (Modem—D30:F3)

Address Offset: 0Ah Attribute: RO
 Default Value: 03h Size: 8 bits
 Lockable: No Power Well: Core

Bit	Description
7:0	Sub Class Code — RO. 03h = Generic Modem.

17.1.8 BCC—Base Class Code Register (Modem—D30:F3)

Address Offset: 0Bh Attribute: RO
 Default Value: 07h Size: 8 bits
 Lockable: No Power Well: Core

Bit	Description
7:0	Base Class Code — RO. 07h = Simple Communications controller.

17.1.9 HEADTYP—Header Type Register (Modem—D30:F3)

Address Offset:	0Eh	Attribute:	RO
Default Value:	00h	Size:	8 bits
Lockable:	No	Power Well:	Core

Bit	Description
7:0	Header Type — RO.

17.1.10 MMBAR—Modem Mixer Base Address Register (Modem—D30:F3)

Address Offset:	10–13h	Attribute:	R/W, RO
Default Value:	0000001h	Size:	32 bits

The Native PCI Mode Modem uses PCI Base Address register #1 to request a contiguous block of I/O space that is to be used for the Modem Mixer software interface. The mixer requires 256 bytes of I/O space. All accesses to the mixer registers are forwarded over the AC-link to the codec where the registers reside.

In the case of the split codec implementation accesses to the different codecs are differentiated by the controller by using address offsets 00h–7Fh for the primary codec and address offsets 80h–FEh for the secondary codec.

Bit	Description
31:16	Hardwired to 0's.
15:8	Base Address — R/W. These bits are used in the I/O space decode of the Modem interface registers. The number of upper bits that a device actually implements depends on how much of the address space the device will respond to. For the AC '97 Modem, the upper 16 bits are hardwired to 0, while bits 15:8 are programmable. This configuration yields a maximum I/O block size of 256 bytes for this base address.
7:1	Reserved. Read as 0
0	Resource Type Indicator (RTE) — RO. Hardwired to 1 indicating a request for I/O space.

17.1.11 MBAR—Modem Base Address Register (Modem—D30:F3)

Address Offset:	14–17h	Attribute:	R/W, RO
Default Value:	0000001h	Size:	32 bits

The Modem function uses PCI Base Address register #1 to request a contiguous block of I/O space that is to be used for the Modem software interface. The Modem Bus Mastering register space requires 128 bytes of I/O space. All Modem registers reside in the controller, therefore cycles are **not** forwarded over the AC-link to the codec.

Bit	Description
31:16	Hardwired to 0's.
15:7	Base Address — R/W. These bits are used in the I/O space decode of the Modem interface registers. The number of upper bits that a device actually implements depends on how much of the address space the device will respond to. For the AC '97 Modem, the upper 16 bits are hardwired to 0, while bits 15:7 are programmable. This configuration yields a maximum I/O block size of 128 bytes for this base address.
6:1	Reserved. Read as 0
0	Resource Type Indicator (RTE) — RO. Hardwired to 1 indicating a request for I/O space.

17.1.12 SVID—Subsystem Vendor Identification Register (Modem—D30:F3)

Address Offset:	2C–2Dh	Attribute:	R/WO
Default Value:	0000h	Size:	16 bits
Lockable:	No	Power Well:	Core

The SVID register, in combination with the Subsystem ID register, enable the operating environment to distinguish one audio subsystem from the other(s). This register is implemented as write-once register. Once a value is written to it, the value can be read back. Any subsequent writes will have no effect.

This register is not affected by the D3_{HOT} to D0 transition.

Bit	Description
15:0	Subsystem Vendor ID — R/WO.

17.1.13 SID—Subsystem Identification Register (Modem—D30:F3)

Address Offset:	2E–2Fh	Attribute:	R/WO
Default Value:	0000h	Size:	16 bits
Lockable:	No	Power Well:	Core

The SID register, in combination with the Subsystem Vendor ID register make it possible for the operating environment to distinguish one audio subsystem from another. This register is implemented as write-once register. Once a value is written to it, the value can be read back. Any subsequent writes will have no effect.

This register is not affected by the D3_{H0T} to D0 transition.

Bit	Description
15:0	Subsystem ID — R/WO.

17.1.14 CAP_PTR—Capabilities Pointer Register (Modem—D30:F3)

Address Offset:	34h	Attribute:	RO
Default Value:	50h	Size:	8 bits
Lockable:	No	Power Well:	Core

This register indicates the offset for the capability pointer.

Bit	Description
7:0	Capabilities Pointer (CAP_PTR) — RO. This field indicates that the first capability pointer offset is offset 50h

17.1.15 INT_LN—Interrupt Line Register (Modem—D30:F3)

Address Offset:	3Ch	Attribute:	R/W
Default Value:	00h	Size:	8 bits
Lockable:	No	Power Well:	Core

This register indicates which PCI interrupt line is used for the AC '97 module interrupt.

Bit	Description
7:0	Interrupt Line (INT_LN) — R/W. This data is not used by the Intel [®] ICH6. It is used to communicate to software the interrupt line that the interrupt pin is connected to.

17.1.16 INT_PIN—Interrupt Pin Register (Modem—D30:F3)

Address Offset:	3Dh	Attribute:	RO
Default Value:	See description	Size:	8 bits
Lockable:	No	Power Well:	Core

This register indicates which PCI interrupt pin is used for the AC '97 modem interrupt. The AC '97 interrupt is internally OR'd to the interrupt controller with the PIRQB# signal.

Bit	Description
7:3	Reserved
2:0	Interrupt Pin (INT_PN) — RO. This reflects the value of D30IP.AMIP in chipset configuration space.

17.1.17 PID—PCI Power Management Capability Identification Register (Modem—D30:F3)

Address Offset:	50h	Attribute:	RO
Default Value:	0001h	Size:	16 bits
Lockable:	No	Power Well:	Core

Bit	Description
15:8	Next Capability (NEXT) — RO. This field indicates that this is the last item in the list.
7:0	Capability ID (CAP) — RO. This field indicates that this pointer is a message signaled interrupt capability.

17.1.18 PC—Power Management Capabilities Register (Modem—D30:F3)

Address Offset:	52h	Attribute:	RO
Default Value:	C9C2h	Size:	16 bits
Lockable:	No	Power Well:	Core

Bit	Description
15:11	PME Support — RO. This field indicates PME# can be generated from all D states.
10:9	Reserved.
8:6	Auxiliary Current — RO. This field reports 375 mA maximum Suspend well current required when in the D3 _{COLD} state.
5	Device Specific Initialization (DSI) — RO. This bit indicates that no device-specific initialization is required.
4	Reserved — RO.
3	PME Clock (PMEC) — RO. This bit indicates that PCI clock is not required to generate PME#.
2:0	Version (VS) — RO. This field indicates support for Revision 1.1 of the PCI Power Management Specification.

17.1.19 PCS—Power Management Control and Status Register (Modem—D30:F3)

Address Offset:	54h	Attribute:	R/W, R/WC
Default Value:	0000h	Size:	16 bits
Lockable:	No	Power Well:	Resume

This register is not affected by the D3_{HOT} to D0 transition.

Bit	Description
15	<p>PME Status (PMES) — R/WC.</p> <p>0 = Software clears this bit by writing a 1 to it. 1 = This bit is set when the AC '97 controller would normally assert the PME# signal independent of the state of the PME_En bit. This bit resides in the resume well.</p>
14:9	Reserved — RO.
8	<p>PME Enable (PMEE) — R/W.</p> <p>0 = Disable. 1 = Enable. When set, and if corresponding PMES is also set, the AC '97 controller sets the AC97_STS bit in the GPE0_STS register</p>
7:2	Reserved — RO.
1:0	<p>Power State (PS) — R/W. This field is used both to determine the current power state of the AC '97 controller and to set a new power state. The values are:</p> <p>00 = D0 state 01 = not supported 10 = not supported 11 = D3_{HOT} state</p> <p>When in the D3_{HOT} state, the AC '97 controller's configuration space is available, but the I/O and memory spaces are not. Additionally, interrupts are blocked.</p> <p>If software attempts to write a value of 10b or 01b in to this field, the write operation must complete normally; however, the data is discarded and no state change occurs.</p>

17.2 AC '97 Modem I/O Space (D30:F3)

In the case of the split codec implementation accesses to the modem mixer registers in different codecs are differentiated by the controller by using address offsets 00h–7Fh for the primary codec and address offsets 80h–FEh for the secondary codec. Table 17-2 shows the register addresses for the modem mixer registers.

Table 17-2. Intel® ICH6 Modem Mixer Register Configuration

Register		MMBAR Exposed Registers (D30:F3)
Primary	Secondary	Name
00h:38h	80h:B8h	Intel RESERVED
3Ch	BCh	Extended Modem ID
3Eh	BEh	Extended Modem Stat/Ctrl
40h	C0h	Line 1 DAC/ADC Rate
42h	C2h	<i>Line 2 DAC/ADC Rate</i>
44h	C4h	<i>Handset DAC/ADC Rate</i>
46h	C6h	Line 1 DAC/ADC Level Mute
48h	C8h	<i>Line 2 DAC/ADC Level Mute</i>
4Ah	CAh	<i>Handset DAC/ADC Level Mute</i>
4Ch	CCh	GPIO Pin Config
4Eh	CEh	GPIO Polarity/Type
50h	D0h	GPIO Pin Sticky
52h	D2h	GPIO Pin Wake Up
54h	D4h	GPIO Pin Status
56h	D6h	Misc. Modem AFE Stat/Ctrl
58h	D8h	AC '97 Reserved
5Ah	DAh	Vendor Reserved
7Ch	FCh	Vendor ID1
7Eh	FEh	Vendor ID2

NOTES:

1. Registers in italics are for functions not supported by the ICH6
2. Software should not try to access reserved registers
3. The ICH6 supports a modem codec connected to ACZ_SDIN[2:0], as long as the Codec ID is 00 or 01. However, the ICH6 does not support more than one modem codec. For a complete list of topologies, see your ICH6 enabled Platform Design Guide.

The Global Control (GLOB_CNT) and Global Status (GLOB_STA) registers are aliased to the same global registers in the audio and modem I/O space. Therefore a read/write to these registers in either audio or modem I/O space affects the same physical register. Software could access these registers as bytes, word, DWord quantities, but reads must not cross DWord boundaries.

These registers exist in I/O space and reside in the AC '97 controller. The two channels, Modem in and Modem out, each have their own set of Bus Mastering registers. The following register descriptions apply to both channels. The naming prefix convention used is as follows:

MI = Modem in channel
MO = Modem out channel

Table 17-3. Modem Registers

Offset	Mnemonic	Name	Default	Access
00h–03h	MI_BDBAR	Modem In Buffer Descriptor List Base Address	00000000h	R/W
04h	MI_CIV	Modem In Current Index Value	00h	RO
05h	MI_LVI	Modem In Last Valid Index	00h	R/W
06h–07h	MI_SR	Modem In Status	0001h	R/WC, RO
08h–09h	MI_PICB	Modem In Position In Current Buffer	0000h	RO
0Ah	MI_PIV	Modem In Prefetch Index Value	00h	RO
0Bh	MI_CR	Modem In Control	00h	R/W, R/W (special)
10h–13h	MO_BDBAR	Modem Out Buffer Descriptor List Base Address	00000000h	R/W
14h	MO_CIV	Modem Out Current Index Value	00h	RO
15h	MO_LVI	Modem Out Last Valid	00h	R/W
16h–17h	MO_SR	Modem Out Status	0001h	R/WC, RO
18h–19h	MI_PICB	Modem In Position In Current Buffer	0000h	RO
1Ah	MO_PIV	Modem Out Prefetched Index	00h	RO
1Bh	MO_CR	Modem Out Control	00h	R/W, R/W (special)
3Ch–3Fh	GLOB_CNT	Global Control	00000000h	R/W, R/W (special)
40h–43h	GLOB_STA	Global Status	00300000h	RO, R/W, R/WC
44h	CAS	Codec Access Semaphore	00h	R/W (special)

NOTE:

1. MI = Modem in channel; MO = Modem out channel

Note: Internal reset as a result of D3_{HOT} to D0 transition will reset all the core well registers except the registers shared with the AC '97 audio controller (GCR, GSR, CASR). All resume well registers will not be reset by the D3_{HOT} to D0 transition.

Core well registers and bits **not** reset by the D3_{HOT} to D0 transition:

- offset 3Ch–3Fh – bits [6:0] Global Control (GLOB_CNT)
- offset 40h–43h – bits [29,15,11:10] Global Status (GLOB_STA)
- offset 44h – Codec Access Semaphore Register (CAS)

Resume well registers and bits **will not** be reset by the D3_{HOT} to D0 transition:

- offset 40h–43h – bits [17:16] Global Status (GLOB_STA)

17.2.1 **x_BDBAR—Buffer Descriptor List Base Address Register (Modem—D30:F3)**

I/O Address:	MBAR + 00h (MIBDBAR), MBAR + 10h (MOBDBAR)	Attribute:	R/W
Default Value:	00000000h	Size:	32bits
Lockable:	No	Power Well:	Core

Software can read the register at offset 00h by performing a single, 32-bit read from address offset 00h. Reads across DWord boundaries are not supported.

Bit	Description
31:3	Buffer Descriptor List Base Address [31:3] — R/W. These bits represent address bits 31:3. The entries should be aligned on 8-byte boundaries.
2:0	Hardwired to 0.

17.2.2 **x_CIV—Current Index Value Register (Modem—D30:F3)**

I/O Address:	MBAR + 04h (MICIV), MBAR + 14h (MOCIV),	Attribute:	RO
Default Value:	00h	Size:	8bits
Lockable:	No	Power Well:	Core

Software can read the registers at offsets 04h, 05h and 06h simultaneously by performing a single, 32-bit read from address offset 04h. Software can also read this register individually by doing a single, 8-bit read to offset 04h. Reads across DWord boundaries are not supported.

Bit	Description
7:5	Hardwired to 0.
4:0	Current Index Value [4:0] — RO. These bits represent which buffer descriptor within the list of 16 descriptors is being processed currently. As each descriptor is processed, this value is incremented.

17.2.3 **x_LVI—Last Valid Index Register (Modem—D30:F3)**

I/O Address:	MBAR + 05h (MILVI), MBAR + 15h (MOLVI)	Attribute:	R/W
Default Value:	00h	Power Well:	Core

Software can read the registers at offsets 04h, 05h and 06h simultaneously by performing a single, 32-bit read from address offset 04h. Software can also read this register individually by doing a single, 8-bit read to offset 05h. Reads across DWord boundaries are not supported.

Bit	Description
7:5	Hardwired to 0
4:0	Last Valid Index [4:0] — R/W. These bits indicate the last valid descriptor in the list. This value is updated by the software as it prepares new buffers and adds to the list.

17.2.4 x_SR—Status Register (Modem—D30:F3)

I/O Address:	MBAR + 06h (MISR), MBAR + 16h (MOSR)	Attribute:	R/WC, RO
Default Value:	0001h	Size:	16 bits
Lockable:	No	Power Well:	Core

Software can read the registers at offsets 04h, 05h and 06h simultaneously by performing a single, 32-bit read from address offset 04h. Software can also read this register individually by doing a single, 16-bit read to offset 06h. Reads across DWord boundaries are not supported.

Bit	Description
15:5	Reserved
4	<p>FIFO Error (FIFOE) — R/WC. 0 = Software clears this bit by writing a 1 to it. 1 = FIFO error occurs.</p> <p>Modem in: FIFO error indicates a FIFO overrun. The FIFO pointers don't increment, the incoming data is not written into the FIFO, thereby being lost.</p> <p>Modem out: FIFO error indicates a FIFO underrun. The sample transmitted in this case should be the last valid sample.</p> <p>The ICH6 will set the FIFOE bit if the under-run or overrun occurs when there are more valid buffers to process.</p>
3	<p>Buffer Completion Interrupt Status (BCIS) — R/WC. 0 = Software clears this bit by writing a 1 to it. 1 = Set by the hardware after the last sample of a buffer has been processed, AND if the Interrupt on Completion (IOC) bit is set in the command byte of the buffer descriptor. Remains active until software clears bit.</p>
2	<p>Last Valid Buffer Completion Interrupt (LVBCI) — R/WC. 0 = Software clears this bit by writing a 1 to it. 1 = Set by hardware when last valid buffer has been processed. It remains active until cleared by software. This bit indicates the occurrence of the event signified by the last valid buffer being processed. Thus, this is an event status bit that can be cleared by software once this event has been recognized. This event will cause an interrupt if the enable bit in the Control Register is set. The interrupt is cleared when the software clears this bit.</p> <p>In the case of transmits (PCM out, Modem out) this bit is set, after the last valid buffer has been fetched (not after transmitting it). While in the case of Receives, this bit is set after the data for the last buffer has been written to memory.</p>
1	<p>Current Equals Last Valid (CELV) — RO. 0 = Hardware clears when controller exists state (i.e., until a new value is written to the LVI register). 1 = Current Index is equal to the value in the Last Valid Index Register, AND the buffer pointed to by the CIV has been processed (i.e., after the last valid buffer has been processed). This bit is very similar to bit 2, except, this bit reflects the state rather than the event. This bit reflects the state of the controller, and remains set until the controller exits this state.</p>
0	<p>DMA Controller Halted (DCH) — RO. 0 = Running. 1 = Halted. This could happen because of the Start/Stop bit being cleared and the DMA engines are idle, or it could happen once the controller has processed the last valid buffer.</p>

17.2.5 x_PICB—Position in Current Buffer Register (Modem—D30:F3)

I/O Address:	MBAR + 08h (MIPICB), MBAR + 18h (MOPICB),	Attribute:	RO
Default Value:	0000h	Size:	16 bits
Lockable:	No	Power Well:	Core

Software can read the registers at the offsets 08h, 0Ah, and 0Bh by performing a 32-bit read from the address offset 08h. Software can also read this register individually by doing a single, 16-bit read to offset 08h. Reads across DWord boundaries are not supported.

Bit	Description
15:0	Position In Current Buffer[15:0] — RO. These bits represent the number of samples left to be processed in the current buffer.

17.2.6 x_PIV—Prefetch Index Value Register (Modem—D30:F3)

I/O Address:	MBAR + 0Ah (MIPIV), MBAR + 1Ah (MOPIV)	Attribute:	RO
Default Value:	00h	Size:	8 bits
Lockable:	No	Power Well:	Core

Software can read the registers at the offsets 08h, 0Ah, and 0Bh by performing a 32-bit read from the address offset 08h. Software can also read this register individually by doing a single, 8-bit read to offset 0Ah. Reads across DWord boundaries are not supported.

Bit	Description
7:5	Hardwired to 0
4:0	Prefetched Index Value [4:0] — RO. These bits represent which buffer descriptor in the list has been prefetched.

17.2.7 x_CR—Control Register (Modem—D30:F3)

I/O Address:	MBAR + 0Bh (MICR), MBAR + 1Bh (MOCR)	Attribute:	R/W, R/W (special)
Default Value:	00h	Size:	8 bits
Lockable:	No	Power Well:	Core

Software can read the registers at the offsets 08h, 0Ah, and 0Bh by performing a 32-bit read from the address offset 08h. Software can also read this register individually by doing a single, 8-bit read to offset 0Bh. Reads across DWord boundaries are not supported.

Bit	Description
7:5	Reserved
4	Interrupt on Completion Enable (IOCE) — R/W. This bit controls whether or not an interrupt occurs when a buffer completes with the IOC bit set in its descriptor. 0 = Disable 1 = Enable
3	FIFO Error Interrupt Enable (FEIE) — R/W. This bit controls whether the occurrence of a FIFO error will cause an interrupt or not. 0 = Disable. Bit 4 in the Status Register will be set, but the interrupt will not occur. 1 = Enable. Interrupt will occur
2	Last Valid Buffer Interrupt Enable (LVBIE) — R/W. This bit controls whether the completion of the last valid buffer will cause an interrupt or not. 0 = Disable. Bit 2 in the Status register will still be set, but the interrupt will not occur. 1 = Enable
1	Reset Registers (RR) — R/W (special). 0 = Removes reset condition. 1 = Contents of all registers to be reset, except the interrupt enable bits (bit 4,3,2 of this register). Software needs to set this bit. It must be set only when the Run/Pause bit is cleared. Setting it when the Run bit is set will cause undefined consequences. This bit is self-clearing (software needs not clear it).
0	Run/Pause Bus Master (RPBM) — R/W. 0 = Pause bus master operation. This results in all state information being retained (i.e., master mode operation can be stopped and then resumed). 1 = Run. Bus master operation starts.

17.2.8 GLOB_CNT—Global Control Register (Modem—D30:F3)

I/O Address:	MBAR + 3Ch	Attribute:	R/W, R/W (special)
Default Value:	00000000h	Size:	32 bits
Lockable:	No	Power Well:	Core

Bit	Description
31:6	Reserved.
6	ACZ_SDIN2 Interrupt Enable (S2RE) — R/W. 0 = Disable. 1 = Enable an interrupt to occur when the codec on the ACZ_SDIN2 causes a resume event on the AC-link.
5	ACZ_SDIN1 Resume Interrupt Enable (S1RE) — R/W. 0 = Disable. 1 = Enable an interrupt to occur when the codec on the ACZ_SDIN1 causes a resume event on the AC-link.
4	ACZ_SDIN0 Resume Interrupt Enable (S0RE) — R/W. 0 = Disable. 1 = Enable an interrupt to occur when the codec on ACZ_SDIN0 causes a resume event on the AC-link.
3	AC-LINK Shut Off (LSO) — R/W. 0 = Normal operation. 1 = Controller disables all outputs which will be pulled low by internal pull down resistors.
2	AC '97 Warm Reset — R/W (special). 0 = Normal operation. 1 = Writing a 1 to this bit causes a warm reset to occur on the AC-link. The warm reset will awaken a suspended codec without clearing its internal registers. If software attempts to perform a warm reset while bit_clk is running, the write will be ignored and the bit will not change. This bit is self-clearing (it remains set until the reset completes and bit_clk is seen on the AC-link, after which it clears itself).
1	AC '97 Cold Reset# — R/W. 0 = Writing a 0 to this bit causes a cold reset to occur throughout the AC '97 circuitry. All data in the controller and the codec will be lost. Software needs to clear this bit no sooner than the minimum number of ms have elapsed. 1 = This bit defaults to 0 and hence after reset, the driver needs to set this bit to a 1. The value of this bit is retained after suspends; hence, if this bit is set to a 1 prior to suspending, a cold reset is not generated automatically upon resuming. Note: This bit is in the Core well.
0	GPI Interrupt Enable (GIE) — R/W. This bit controls whether the change in status of any GPI causes an interrupt. 0 = Bit 0 of the Global Status Register is set, but no interrupt is generated. 1 = The change on value of a GPI causes an interrupt and sets bit 0 of the Global Status Register. NOTE: This bit is cleared by the AC '97 Modem function D3 _{HOT} to D0 reset.

Note: Reads across DWord boundaries are not supported.

17.2.9 GLOB_STA—Global Status Register (Modem—D30:F3)

I/O Address:	MBAR + 40h	Attribute:	RO, R/W, R/WC
Default Value:	00300000h	Size:	32 bits
Lockable:	No	Power Well:	Core

Bit	Description
31:30	Reserved.
29	ACZ_SDIN2 Resume Interrupt (S2RI) — R/WC. This bit indicates a resume event occurred on ACZ_SDIN2. 0 = Software clears this bit by writing a 1 to it. 1 = Resume event occurred. This bit is not affected by D3 _{HOT} to D0 Reset.
28	ACZ_SDIN2 Codec Ready (S2CR) — RO. This bit reflects the state of the codec ready bit on ACZ_SDIN2. Bus masters ignore the condition of the codec ready bits, so software must check this bit before starting the bus masters. Once the codec is “ready”, it must never go “not ready” spontaneously. 0 = Not Ready. 1 = Ready.
27	Bit Clock Stopped (BCS) — RO. This bit indicates that the bit clock is not running. 0 = Transition is found on BIT_CLK. 1 = Intel® ICH6 detects that there has been no transition on BIT_CLK for four consecutive PCI clocks.
26	S/PDIF* Interrupt (SPINT) — RO. 0 = When the specific status bit is cleared, this bit will be cleared. 1 = S/PDIF out channel interrupt status bits have been set.
25	PCM In 2 Interrupt (P2INT) — RO. 0 = When the specific status bit is cleared, this bit will be cleared. 1 = One of the PCM In 2 channel status bits have been set.
24	Microphone 2 In Interrupt (M2INT) — RO. 0 = When the specific status bit is cleared, this bit will be cleared. 1 = One of the Mic in channel interrupts status bits has been set.
23:22	Sample Capabilities — RO. This field indicates the capability to support more greater than 16-bit audio. 00 = Reserved 01 = 16 and 20-bit Audio supported (ICH6 value) 10 = Reserved 11 = Reserved
21:20	Multichannel Capabilities — RO. This field indicates the capability to support 4 and 6 channels on PCM Out.
19:18	Reserved.
17	MD3 — R/W. Power down semaphore for Modem. This bit exists in the suspend well and maintains context across power states (except G3). The bit has no hardware function. It is used by software in conjunction with the AD3 bit to coordinate the entry of the two codecs into D3 state. This bit is not affected by D3 _{HOT} to D0 Reset.
16	AD3 — R/W. Power down semaphore for Audio. This bit exists in the suspend well and maintains context across power states (except G3). The bit has no hardware function. It is used by software in conjunction with the MD3 bit to coordinate the entry of the two codecs into D3 state. This bit is not affected by D3 _{HOT} to D0 Reset.
15	Read Completion Status (RCS) — R/WC. This bit indicates the status of codec read completions. Software clears this bit by writing a 1 to it. 0 = A codec read completes normally. 1 = A codec read results in a time-out. This bit is not affected by D3 _{HOT} to D0 Reset.

Bit	Description
14	Bit 3 of Slot 12 — RO. Display bit 3 of the most recent slot 12.
13	Bit 2 of Slot 12 — RO. Display bit 2 of the most recent slot 12.
12	Bit 1 of Slot 12 — RO. Display bit 1 of the most recent slot 12.
11	ACZ_SDIN1 Resume Interrupt (S1RI) — R/WC. This bit indicates that a resume event occurred on ACZ_SDIN1. Software clears this bit by writing a 1 to it. 0 = Resume event did Not occur. 1 = Resume event occurred. This bit is not affected by D3 _{HOT} to D0 Reset.
10	ACZ_SDIN0 Resume Interrupt (S0RI) — R/WC. This bit indicates that a resume event occurred on ACZ_SDIN0. Software clears this bit by writing a 1 to it. 0 = Resume event did Not occur. 1 = Resume event occurred. This bit is not affected by D3 _{HOT} to D0 Reset.
9	ACZ_SDIN1 Codec Ready (S1CR) — RO. This bit reflects the state of the codec ready bit in ACZ_SDIN1. Bus masters ignore the condition of the codec ready bits, so software must check this bit before starting the bus masters. Once the codec is “ready”, it must never go “not ready” spontaneously. 0 = Not Ready. 1 = Ready.
8	ACZ_SDIN0 Codec Ready (S0CR) — RO. This bit reflects the state of the codec ready bit in ACZ_SDIN 0. Bus masters ignore the condition of the codec ready bits, so software must check this bit before starting the bus masters. Once the codec is “ready”, it must never go “not ready” spontaneously. 0 = Not Ready. 1 = Ready.
7	Microphone In Interrupt (MINT) — RO. 0 = When the specific status bit is cleared, this bit will be cleared. 1 = One of the Mic in channel interrupts status bits has been set.
6	PCM Out Interrupt (POINT) — RO. 0 = When the specific status bit is cleared, this bit will be cleared. 1 = One of the PCM out channel interrupts status bits has been set.
5	PCM In Interrupt (PIINT) — RO. 0 = When the specific status bit is cleared, this bit will be cleared. 1 = One of the PCM in channel interrupts status bits has been set.
4:3	Reserved
2	Modem Out Interrupt (MOINT) — RO. 0 = When the specific status bit is cleared, this bit will be cleared. 1 = One of the modem out channel interrupts status bits has been set.
1	Modem In Interrupt (MIINT) — RO. 0 = When the specific status bit is cleared, this bit will be cleared. 1 = One of the modem in channel interrupts status bits has been set.
0	GPI Status Change Interrupt (GSCI) — R/WC. 0 = Software clears this bit by writing a 1 to it. 1 = This bit reflects the state of bit 0 in slot 12, and is set when bit 0 of slot 12 is set. This indicates that one of the GPI's changed state, and that the new values are available in slot 12. This bit is not affected by AC '97 Audio Modem function D3 _{HOT} to D0 Reset.

Note: On reads from a codec, the controller will give the codec a maximum of four frames to respond, after which if no response is received, it will return a dummy read completion to the processor (with all F's on the data) and also set the Read Completion Status bit in the Global Status Register.

Note: Reads across DWord boundaries are not supported.

17.2.10 CAS—Codec Access Semaphore Register (Modem—D30:F3)

I/O Address:	NABMBAR + 44h	Attribute:	R/W (special)
Default Value:	00h	Size:	8 bits
Lockable:	No	Power Well:	Core

Bit	Description
7:1	Reserved
0	<p>Codec Access Semaphore (CAS) — R/W (special). This bit is read by software to check whether a codec access is currently in progress.</p> <p>0 = No access in progress. 1 = The act of reading this register sets this bit to 1. The driver that read this bit can then perform an I/O access. Once the access is completed, hardware automatically clears this bit.</p>

Note: Reads across DWord boundaries are not supported.

§



18 Intel® High Definition Audio Controller Registers (D27:F0)

The Intel High Definition Audio controller resides in PCI Device 27, Function 0 on bus 0. This function contains a set of DMA engines that are used to move samples of digitally encoded data between system memory and external codecs.

Note: All registers in this function (including memory-mapped registers) must be addressable in byte, word, and D-word quantities. The software must always make register accesses on natural boundaries (i.e. D-word accesses must be on D-word boundaries; word accesses on word boundaries, etc.) In addition, the memory-mapped register space must not be accessed with the LOCK semantic exclusive-access mechanism. If software attempts exclusive-access mechanisms to the Intel High Definition Audio memory-mapped space, the results are undefined.

Note: Users interested in providing feedback on the Intel High Definition Audio specification or planning to implement the Intel High Definition Audio specification into a future product will need to execute the Intel High Definition Audio Specification Developer’s Agreement. For more information, contact nextgenaudio@intel.com.

18.1 Intel® High Definition Audio PCI Configuration Space (Intel® High Definition Audio— D27:F0)

Note: Address locations that are not shown should be treated as Reserved.

Table 18-1. Intel® High Definition Audio PCI Register Address Map (Intel® High Definition Audio D27:F0) (Sheet 1 of 2)

Offset	Mnemonic	Register Name	Default	Access
00–01h	VID	Vendor Identification	8086h	RO
02–03h	DID	Device Identification	2668h	RO
04–05h	PCICMD	PCI Command	0000h	R/W, RO
06–07h	PCISTS	PCI Status	0010h	R/WC, RO
08h	RID	Revision Identification	See register description.	RO
09h	PI	Programming Interface	00h	RO
0Ah	SCC	Sub Class Code	03h	RO
0Bh	BCC	Base Class Code	04h	RO
0Ch	CLS	Cache Line Size	00h	R/W
0Dh	LT	Latency Timer	00h	RO
0Eh	HEADTYP	Header Type	00h	RO
10–13h	HDBARL	Intel High Definition Audio Lower Base Address (Memory)	00000004h	R/W, RO

Table 18-1. Intel® High Definition Audio PCI Register Address Map (Intel® High Definition Audio D27:F0) (Sheet 2 of 2)

Offset	Mnemonic	Register Name	Default	Access
14–17h	HDBARU	Intel High Definition Audio Upper Base Address (Memory)	00000000h	R/W
2C–2Dh	SVID	Subsystem Vendor Identification	0000h	R/WO
2E–2Fh	SID	Subsystem Identification	0000h	R/WO
34h	CAPPTR	Capability List Pointer	50h	RO
3Ch	INTLN	Interrupt Line	00h	R/W
3Dh	INTPN	Interrupt Pin	See Register Description	RO
40h	HDCTL	Intel High Definition Audio Control	00h	R/W, RO
44h	TCSEL	Traffic Class Select	00h	R/W
50–51h	PID	PCI Power Management Capability ID	6001h	RO
52–53h	PC	Power Management Capabilities	C842	RO
54–57h	PCS	Power Management Control and Status	00000000h	R/W, RO, R/WC
60–61h	MID	MSI Capability ID	7005h	RO
62–63h	MMC	MSI Message Control	0080h	R/W, RO
64–67h	MMLA	MSI Message Lower Address	00000000h	R/W, RO
68–6Bh	MMUA	SMI Message Upper Address	00000000h	R/W
6C–6Dh	MMD	MSI Message Data	0000h	R/W
70–71h	PXID	PCI Express* Capability Identifiers	0010h	RO
72–73h	PXC	PCI Express Capabilities	0091h	RO
74–77h	DEVCAP	Device Capabilities	00000000h	RO, R/WO
78–79h	DEVC	Device Control	0800h	R/W, RO
7A–7Bh	DEVS	Device Status	0010h	RO
100–103h	VCCAP	Virtual Channel Enhanced Capability Header	13010002h	RO
104–107h	PVCCAP1	Port VC Capability Register 1	00000001h	RO
108–10Bh	PVCCAP2	Port VC Capability Register 2	00000000h	RO
10C–10D	PVCCTL	Port VC Control	0000h	RO
10E–10Fh	PVCSTS	Port VC Status	0000h	RO
110–103h	VC0CAP	VC0 Resource Capability	00000000h	RO
114–117h	VC0CTL	VC0 Resource Control	800000FFh	R/W, RO
11A–11Bh	VC0STS	VC0 Resource Status	0000h	RO
11C–11Fh	VCiCAP	VCi Resource Capability	00000000h	RO
120–123h	VCiCTL	VCi Resource Control	00000000h	R/W, RO
126–127h	VCiSTS	VCi Resource Status	0000h	RO
130–133h	RCCAP	Root Complex Link Declaration Enhanced Capability Header	00010005h	RO
134–137h	ESD	Element Self Description	05000100h	RO
140–143h	L1DESC	Link 1 Description	00000001h	RO
148–14Bh	L1ADDL	Link 1 Lower Address	See Register Description	RO
14C–14Fh	L1ADDU	Link 1 Upper Address	See Register Description	RO

18.1.1 VID—Vendor Identification Register (Intel® High Definition Audio Controller—D27:F0)

Offset: 00-01h Attribute: RO
 Default Value: 8086h Size: 16 bits

Bit	Description
15:0	Vendor ID — RO. This is a 16-bit value assigned to Intel. Intel VID = 8086h

18.1.2 DID—Device Identification Register (Intel® High Definition Audio Controller—D27:F0)

Offset Address: 02-03h Attribute: RO
 Default Value: 2668h Size: 16 bits

Bit	Description
15:0	Device ID — RO. This is a 16-bit value assigned to the ICH6 Intel High Definition Audio controller.

18.1.3 PCICMD—PCI Command Register (Intel® High Definition Audio Controller—D27:F0)

Offset Address: 04-05h Attribute: R/W, RO
 Default Value: 0000h Size: 16 bits

Bit	Description
15:11	Reserved
10	Interrupt Disable (ID) — R/W. 0= The INTx# signals may be asserted. 1= The Intel High Definition Audio controller's INTx# signal will be de-asserted Note that this bit does not affect the generation of MSI's.
9	Fast Back to Back Enable (FBE) — RO. Not implemented. Hardwired to 0.
8	SERR# Enable (SERR_EN) — RO. Not implemented. Hardwired to 0.
7	Wait Cycle Control (WCC) — RO. Not implemented. Hardwired to 0.
6	Parity Error Response (PER) — RO. Not implemented. Hardwired to 0.
5	VGA Palette Snoop (VPS) . Not implemented. Hardwired to 0.
4	Memory Write and Invalidate Enable (MWIE) — RO. Not implemented. Hardwired to 0.
3	Special Cycle Enable (SCE) . Not implemented. Hardwired to 0.
2	Bus Master Enable (BME) — R/W. This bit controls standard PCI Express* bus mastering capabilities for Memory and I/O, reads and writes. Note that this bit also controls MSI generation since MSIs are essentially Memory writes. 0 = Disable 1 = Enable
1	Memory Space Enable (MSE) — R/W. This bit enables memory space addresses to the Intel High Definition Audio controller. 0 = Disable 1 = Enable
0	I/O Space Enable (IOSE) —RO. Hardwired to 0 since the Intel High Definition Audio controller does not implement I/O space.

18.1.4 PCISTS—PCI Status Register (Intel® High Definition Audio Controller—D27:F0)

Offset Address: 06–07h Attribute: RO, R/WC
 Default Value: 0010h Size: 16 bits

Bit	Description
15	Detected Parity Error (DPE) — RO. Not implemented. Hardwired to 0.
14	SERR# Status (SERRS) — RO. Not implemented. Hardwired to 0.
13	Received Master Abort (RMA) — R/WC. Software clears this bit by writing a 1 to it. 0 = No master abort received. 1 = The Intel High Definition Audio controller sets this bit when, as a bus master, it receives a master abort. When set, the Intel High Definition Audio controller clears the run bit for the channel that received the abort.
12	Received Target Abort (RTA) — RO. Not implemented. Hardwired to 0.
11	Signaled Target Abort (STA) — RO. Not implemented. Hardwired to 0.
10:9	DEVSEL# Timing Status (DEV_STS) — RO. Does not apply. Hardwired to 0.
8	Data Parity Error Detected (DPED) — RO. Not implemented. Hardwired to 0.
7	Fast Back to Back Capable (FB2BC) — RO. Does not apply. Hardwired to 0.
6	Reserved.
5	66 MHz Capable (66MHZ_CAP) — RO. Does not apply. Hardwired to 0.
4	Capabilities List (CAP_LIST) — RO. Hardwired to 1. Indicates that the controller contains a capabilities pointer list. The first item is pointed to by looking at configuration offset 34h.
3	Interrupt Status (IS) — RO. 0 = This bit is 0 after the interrupt is cleared. 1 = This bit is 1 when the INTx# is asserted. Note that this bit is not set by an MSI.
2:0	Reserved.

18.1.5 RID—Revision Identification Register (Intel® High Definition Audio Controller—D27:F0)

Offset: 08h Attribute: RO
 Default Value: See bit description Size: 8 Bits

Bit	Description
7:0	Revision ID — RO. Refer to the Intel® ICH6 Family Datasheet Specification Update for the value of the Revision ID Register

18.1.6 PI—Programming Interface Register (Intel® High Definition Audio Controller—D27:F0)

Offset: 09h Attribute: RO
 Default Value: 00h Size: 8 bits

Bit	Description
7:0	Programming Interface — RO.

18.1.7 SCC—Sub Class Code Register (Intel® High Definition Audio Controller—D27:F0)

Address Offset: 0Ah Attribute: RO
 Default Value: 03h Size: 8 bits

Bit	Description
7:0	Sub Class Code (SCC) — RO. 03h = Audio Device

18.1.8 BCC—Base Class Code Register (Intel® High Definition Audio Controller—D27:F0)

Address Offset: 0Bh Attribute: RO
 Default Value: 04h Size: 8 bits

Bit	Description
7:0	Base Class Code (BCC) — RO. 04h = Multimedia device

18.1.9 CLS—Cache Line Size Register (Intel® High Definition Audio Controller—D27:F0)

Address Offset: 0Ch Attribute: R/W
 Default Value: 00h Size: 8 bits

Bit	Description
7:0	Cache Line Size — R/W. Implemented as R/W register, but has no functional impact to the ICH6

18.1.14 SVID—Subsystem Vendor Identification Register (Intel[®] High Definition Audio Controller—D27:F0)

Address Offset: 2C–2Dh Attribute: R/WO
 Default Value: 0000h Size: 16 bits

The SVID register, in combination with the Subsystem ID register (D27:F0:2Eh), enable the operating environment to distinguish one audio subsystem from the other(s).

This register is implemented as write-once register. Once a value is written to it, the value can be read back. Any subsequent writes will have no effect.

This register is not affected by the D3_{HOT} to D0 transition.

Bit	Description
15:0	Subsystem Vendor ID — R/WO.

18.1.15 SID—Subsystem Identification Register (Intel[®] High Definition Audio Controller—D27:F0)

Address Offset: 2E–2Fh Attribute: R/WO
 Default Value: 0000h Size: 16 bits

The SID register, in combination with the Subsystem Vendor ID register (D27:F0:2Ch) make it possible for the operating environment to distinguish one audio subsystem from the other(s).

This register is implemented as write-once register. Once a value is written to it, the value can be read back. Any subsequent writes will have no effect.

This register is not affected by the D3_{HOT} to D0 transition.

Bit	Description
15:0	Subsystem ID — R/WO.

18.1.16 CAPPTR—Capabilities Pointer Register (Audio—D30:F2)

Address Offset: 34h Attribute: RO
 Default Value: 50h Size: 8 bits

This register indicates the offset for the capability pointer.

Bit	Description
7:0	Capabilities Pointer (CAP_PTR) — RO. This field indicates that the first capability pointer offset is offset 50h (Power Management Capability)

18.1.17 INTLN—Interrupt Line Register (Intel® High Definition Audio Controller—D27:F0)

Address Offset: 3Ch Attribute: R/W
Default Value: 00h Size: 8 bits

Bit	Description
7:0	Interrupt Line (INT_LN) — R/W. This data is not used by the Intel® ICH6. It is used to communicate to software the interrupt line that the interrupt pin is connected to.

18.1.18 INTPN—Interrupt Pin Register (Intel® High Definition Audio Controller—D27:F0)

Address Offset: 3Dh Attribute: RO
Default Value: See Description Size: 8 bits

Bit	Description
7:4	Reserved.
3:0	Interrupt Pin — RO. This field reflects the value of D27IP.ZIP (Chipset Configuration Registers:Offset 3110h:bits 3:0).



18.1.19 HDCTL—Intel® High Definition Audio Control Register (Intel® High Definition Audio Controller—D27:F0)

Address Offset:	40h	Attribute:	R/W, RO
Default Value:	00h	Size:	8 bits

Bit	Description
7:4	Reserved.
3	<p>BITCLK Detect Clear (CLKDETCLR) — R/W.</p> <p>0 = When a 0 is written to this bit, the clock detect circuit is operational and maybe enabled.</p> <p>1 = Writing a 1 to this bit clears bit 1 (CLKDET#) in this register. CLKDET# bit remains clear when this bit is set to 1.</p> <p>NOTE: This bit is not affected by the D3_{HOT} to D0 transition.</p>
2	<p>BITCLK Detect Enable (CLKDETEN) — R/W.</p> <p>0 = Latches the current state of bit 1 (CLKDET#) in this register</p> <p>1 = Enables the clock detection circuit</p> <p>NOTE: This bit is not affected by the D3_{HOT} to D0 transition.</p>
1	<p>BITCLK Detected Inverted (CLKDET#) — RO. This bit is modified by hardware. It is set to 0 when the Intel® ICH6 detects that the BITCLK is toggling, indicating the presence of an AC '97 codec on the link.</p> <p>NOTES:</p> <ol style="list-style-type: none"> 1. Bit 2 (CLKDETEN) and bit 3 (CLKDETCLR) in this register control the operation of this bit and must be manipulated correctly in order to get a valid CLKDET# indicator. 2. This bit is not affected by the D3_{HOT} to D0 transition.
0	<p>Intel High Definition Audio/AC '97 Signal Mode — R/W. This bit selects the shared Intel High Definition Audio/AC '97 signals.</p> <p>0 = AC '97 mode is selected (Default)</p> <p>1 = Intel High Definition Audio mode is selected</p> <p>NOTES:</p> <ol style="list-style-type: none"> 1. This bit has no affect on the visibility of the Intel High Definition Audio and AC '97 function configuration space. 2. This bit is in the resume well and only clear on a power-on reset. Software must not makes assumptions about the reset state of this bit and must set it appropriately.

18.1.21 PID—PCI Power Management Capability ID Register (Intel[®] High Definition Audio Controller—D27:F0)

Address Offset: 50h Attribute: RO
Default Value: 6001h Size: 16 bits

Bit	Description
15:8	Next Capability (Next) — RO. Hardwired to 60h. This field points to the next capability structure (MSI)
7:0	Cap ID (CAP) — RO. Hardwired to 01h. This field indicates that this pointer is a PCI power management capability.

18.1.22 PC—Power Management Capabilities Register (Intel[®] High Definition Audio Controller—D27:F0)

Address Offset: 52h Attribute: RO
Default Value: C842h Size: 16 bits

Bit	Description
15:11	PME Support — RO. Hardwired to 11001b. This field indicates PME# can be generated from D3 and D0 states.
10	D2 Support — RO. Hardwired to 0. This bit indicates that D2 state is not supported.
9	D1 Support —RO. Hardwired to 0. This bit indicates that D1 state is not supported.
8:6	Aux Current — RO. Hardwired to 001b. Reports 55 mA maximum suspend well current required when in the D3 _{COLD} state.
5	Device Specific Initialization (DSI) — RO. Hardwired to 0. Indicates that no device specific initialization is required.
4	Reserved
3	PME Clock (PMEC) — RO. Does not apply. Hardwired to 0.
2:0	Version — RO. Hardwired to 010b. This field indicates support for version 1.1 of the PCI Power Management Specification.

18.1.23 PCS—Power Management Control and Status Register (Intel® High Definition Audio Controller—D27:F0)

Address Offset: 54h Attribute: RO, R/W, R/WC
 Default Value: 00000000h Size: 32 bits

Bit	Description
31:24	Data — RO. Does not apply. Hardwired to 0.
23	Bus Power/Clock Control Enable — RO. Does not apply. Hardwired to 0.
22	B2/B3 Support — RO. Does not apply. Hardwired to 0.
21:16	Reserved.
15	<p>PME Status (PMES) — R/WC.</p> <p>0 = Software clears the bit by writing a 1 to it. 1 = This bit is set when the Intel High Definition Audio controller would normally assert the PME# signal independent of the state of the PME_EN bit (bit 8 in this register)</p> <p>This bit in the resume well and only cleared on a power-on reset. Software must not make assumptions about the reset state of this bit and must set it appropriately</p>
14:9	Reserved
8	<p>PME Enable (PMEE) — R/W.</p> <p>0 = Disable 1 = when set and if corresponding PMES also set, the Intel High Definition Audio controller sets the AC97_STS bit in the GPE0_STS register (PMBASE +28h). The AC97_STS bit is shared by AC '97 and Intel High Definition Audio functions since they are mutually exclusive.</p> <p>This bit in the resume well and only cleared on a power-on reset. Software must not make assumptions about the reset state of this bit and must set it appropriately</p>
7:2	Reserved
1:0	<p>Power State (PS) — R/W. This field is used both to determine the current power state of the Intel High Definition Audio controller and to set a new power state.</p> <p>00 = D0 state 11 = D3_{HOT} state Others = reserved</p> <p>NOTES:</p> <ol style="list-style-type: none"> 1. If software attempts to write a value of 01b or 10b in to this field, the write operation must complete normally; however, the data is discarded and no state change occurs. 2. When in the D3_{HOT} states, the Intel High Definition Audio controller's configuration space is available, but the I/O and memory space are not. Additionally, interrupts are blocked. 3. When software changes this value from D3_{HOT} state to the D0 state, an internal warm (soft) reset is generated, and software must re-initialize the function.

18.1.24 MID—MSI Capability ID Register (Intel® High Definition Audio Controller—D27:F0)

Address Offset: 60h Attribute: RO
 Default Value: 7005h Size: 16 bits

Bit	Description
15:8	Next Capability (Next) — RO. Hardwired to 70h. Points to the PCI Express* capability structure.
7:0	Cap ID (CAP) — RO. Hardwired to 05h. Indicates that this pointer is a MSI capability

18.1.25 MMC—MSI Message Control Register (Intel® High Definition Audio Controller—D27:F0)

Address Offset: 62h Attribute: RO, R/W
 Default Value: 0080h Size: 16 bits

Bit	Description
15:8	Reserved
7	64b Address Capability (64ADD) — RO. Hardwired to 1. Indicates the ability to generate a 64-bit message address
6:4	Multiple Message Enable (MME) — RO. Normally this is a R/W register. However since only 1 message is supported, these bits are hardwired to 000 = 1 message.
3:1	Multiple Message Capable (MMC) — RO. Hardwired to 0 indicating request for 1 message.
0	MSI Enable (ME) — R/W. 0 = an MSI may not be generated 1 = an MSI will be generated instead of an INTx signal.

18.1.26 MMLA—MSI Message Lower Address Register (Intel® High Definition Audio Controller—D27:F0)

Address Offset: 64h Attribute: RO, R/W
 Default Value: 00000000h Size: 32 bits

Bit	Description
31:2	Message Lower Address (MLA) — R/W. Lower address used for MSI message.
1:0	Reserved.

18.1.27 MMUA—MSI Message Upper Address Register (Intel® High Definition Audio Controller—D27:F0)

Address Offset: 68h Attribute: R/W
 Default Value: 00000000h Size: 32 bits

Bit	Description
31:0	Message Upper Address (MUA) — R/W. Upper 32-bits of address used for MSI message.

18.1.28 MMD—MSI Message Data Register (Intel® High Definition Audio Controller—D27:F0)

Address Offset: 6Ch Attribute: R/W
 Default Value: 0000h Size: 16 bits

Bit	Description
15:0	Message Data (MD) — R/W. Data used for MSI message.

**18.1.31 DEVCAP—Device Capabilities Register
(Intel® High Definition Audio Controller—D27:F0)**

Address Offset: 74h Attribute: RO, R/WO
 Default Value: 00000000h Size: 32 bits

Bit	Description
31:28	Reserved
27:26	Captured Slot Power Limit Scale (SPLS) — RO. Hardwired to 0.
25:18	Captured Slot Power Limit Value (SPLV) — RO. Hardwired to 0.
17:15	Reserved
14	Power Indicator Present — RO. Hardwired to 0.
13	Attention Indicator Present — RO. Hardwired to 0.
12	Attention Button Present — RO. Hardwired to 0.
11:9	Endpoint L1 Acceptable Latency — R/WO.
8:6	Endpoint L0s Acceptable Latency — R/WO.
5	Extended Tag Field Support — RO. Hardwired to 0. Indicates 5-bit tag field support
4:3	Phantom Functions Supported — RO. Hardwired to 0. This field indicates that phantom functions not supported
2:0	Max Payload Size Supported — RO. Hardwired to 0. This field indicates 128-B maximum payload size capability



18.1.32 DEVC—Device Control Register (Intel® High Definition Audio Controller—D27:F0)

Address Offset: 78h Attribute: R/W, RO
Default Value: 0800h Size: 16 bits

Bit	Description
15	Reserved
14:12	Max Read Request Size — RO. Hardwired to 0 enabling 128B maximum read request size.
11	<p>No Snoop Enable (NSNPEN) — R/W.</p> <p>0 = The Intel High Definition Audio controller will not set the No Snoop bit. In this case, isochronous transfers will not use VC1 (VCi) even if it is enabled since VC1 is never snooped. Isochronous transfers will use VC0.</p> <p>1 = The Intel High Definition Audio controller is permitted to set the No Snoop bit in the Requester Attributes of a bus master transaction. In this case, VC0 or VC1 may be used for isochronous transfers.</p> <p>Note: This bit is not reset on D3_{HOT} to D0 transition; however, it is reset by PLTRST#.</p>
10	Auxiliary Power Enable — RO. Hardwired to 0, indicating that Intel High Definition Audio device does not draw AUX power
9	Phantom Function Enable — RO. Hardwired to 0 disabling phantom functions.
8	Extended Tag Field Enable — RO. Hardwired to 0 enabling 5-bit tag.
7:5	Max Payload Size — RO. Hardwired to 0 indicating 128B.
4	Enable Relaxed Ordering — RO. Hardwired to 0 disabling relaxed ordering.
3	Unsupported Request Reporting Enable — RO. Not implemented. Hardwired to 0.
2	Fatal Error Reporting Enable — RO. Not implemented. Hardwired to 0.
1	Non-Fatal Error Reporting Enable — RO. Not implemented. Hardwired to 0.
0	Correctable Error Reporting Enable — RO. Not implemented. Hardwired to 0.

**18.1.33 DEVS—Device Status Register
(Intel® High Definition Audio Controller—D27:F0)**

Address Offset:	7Ah	Attribute:	RO
Default Value:	0010h	Size:	16 bits

Bit	Description
15:6	Reserved
5	Transactions Pending — RO. 0 = Indicates that completions for all non-posted requests have been received 1 = Indicates that Intel High Definition Audio controller has issued non-posted requests which have not been completed.
4	AUX Power Detected — RO. Hardwired to 1 indicating the device is connected to resume power
3	Unsupported Request Detected — RO. Not implemented. Hardwired to 0.
2	Fatal Error Detected — RO. Not implemented. Hardwired to 0.
1	Non-Fatal Error Detected — RO. Not implemented. Hardwired to 0.
0	Correctable Error Detected — RO. Not implemented. Hardwired to 0.

**18.1.34 VCCAP—Virtual Channel Enhanced Capability Header
(Intel® High Definition Audio Controller—D27:F0)**

Address Offset:	100h	Attribute:	RO
Default Value:	13010002h	Size:	32 bits

Bit	Description
31:20	Next Capability Offset — RO. Hardwired to 130h. Points to the next capability header, which is the Root Complex Link Declaration Enhanced Capability Header.
19:16	Capability Version — RO. Hardwired to 1h.
15:0	PCI Express* Extended Capability — RO. Hardwired to 0002h.

18.1.35 PVCCAP1—Port VC Capability Register 1 (Intel® High Definition Audio Controller—D27:F0)

Address Offset: 104h Attribute: RO
Default Value: 00000001h Size: 32 bits

Bit	Description
31:12	Reserved.
11:10	Port Arbitration Table Entry Size — RO. Hardwired to 0 since this is an endpoint device.
9:8	Reference Clock — RO. Hardwired to 0 since this is an endpoint device.
7	Reserved.
6:4	Low Priority Extended VC Count — RO. Hardwired to 0. Indicates that only VC0 belongs to the low priority VC group
3	Reserved.
2:0	Extended VC Count — RO. Hardwired to 001b. Indicates that 1 extended VC (in addition to VC0) is supported by the Intel High Definition Audio controller.

18.1.36 PVCCAP2—Port VC Capability Register 2 (Intel® High Definition Audio Controller—D27:F0)

Address Offset: 108h Attribute: RO
Default Value: 00000000h Size: 32 bits

Bit	Description
31:24	VC Arbitration Table Offset — RO. Hardwired to 0 indicating that a VC arbitration table is not present.
23:8	Reserved.
7:0	VC Arbitration Capability — RO. Hardwired to 0. These bits are not applicable since the Intel High Definition Audio controller reports a 0 in the Low Priority Extended VC Count bits in the PVCCAP1 register.

18.1.37 PVCCTL—Port VC Control Register (Intel® High Definition Audio Controller—D27:F0)

Address Offset: 10Ch Attribute: RO
Default Value: 0000h Size: 16 bits

Bit	Description
15:4	Reserved.
3:1	VC Arbitration Select — RO. Hardwired to 0. Normally these bits are R/W. However, these bits are not applicable since the Intel High Definition Audio controller reports a 0 in the Low Priority Extended VC Count bits in the PVCCAP1 register
0	Load VC Arbitration Table — RO. Hardwired to 0 since an arbitration table is not present.

18.1.38 PVCSTS—Port VC Status Register (Intel® High Definition Audio Controller—D27:F0)

Address Offset: 10Eh Attribute: RO
Default Value: 0000h Size: 16 bits

Bit	Description
15:1	Reserved.
0	VC Arbitration Table Status — RO. Hardwired to 0 since an arbitration table is not present.

18.1.39 VC0CAP—VC0 Resource Capability Register (Intel® High Definition Audio Controller—D27:F0)

Address Offset: 110h Attribute: RO
Default Value: 00000000h Size: 32 bits

Bit	Description
31:24	Port Arbitration Table Offset — RO. Hardwired to 0 since this field is not valid for endpoint devices
23	Reserved.
22:16	Maximum Time Slots — RO. Hardwired to 0 since this field is not valid for endpoint devices
15	Reject Snoop Transactions — RO. Hardwired to 0 since this field is not valid for endpoint devices.
14	Advanced Packet Switching — RO. Hardwired to 0 since this field is not valid for endpoint devices
13:8	Reserved.
7:0	Port Arbitration Capability — RO. Hardwired to 0 since this field is not valid for endpoint devices

18.1.40 VC0CTL—VC0 Resource Control Register (Intel® High Definition Audio Controller—D27:F0)

Address Offset: 114h Attribute: R/W, RO
Default Value: 800000FFh Size: 32 bits

Bit	Description
31	VC0 Enable — RO. Hardwired to 1 for VC0.
30:27	Reserved.
26:24	VC0 ID — RO. Hardwired to 0 since the first VC is always assigned as VC0
23:20	Reserved.
19:17	Port Arbitration Select — RO. Hardwired to 0 since this field is not valid for endpoint devices
16	Load Port Arbitration Table — RO. Hardwired to 0 since this field is not valid for endpoint devices
15:8	Reserved.
7:0	TC/VC0 Map — R/W, RO. Bit 0 is hardwired to 1 since TC0 is always mapped VC0. Bits [7:1] are implemented as R/W bits.

18.1.41 VC0STS—VC0 Resource Status Register (Intel® High Definition Audio Controller—D27:F0)

Address Offset: 11Ah Attribute: RO
Default Value: 0000h Size: 16 bits

Bit	Description
15:2	Reserved.
1	VC0 Negotiation Pending — RO. Hardwired to 0 since this bit does not apply to the integrated Intel High Definition Audio device
0	Port Arbitration Table Status — RO. Hardwired to 0 since this field is not valid for endpoint devices

18.1.42 VCiCAP—VCi Resource Capability Register (Intel® High Definition Audio Controller—D27:F0)

Address Offset: 11Ch Attribute: RO
Default Value: 00000000h Size: 32 bits

Bit	Description
31:24	Port Arbitration Table Offset — RO. Hardwired to 0 since this field is not valid for endpoint devices.
23	Reserved.
22:16	Maximum Time Slots — RO. Hardwired to 0 since this field is not valid for endpoint devices
15	Reject Snoop Transactions — RO. Hardwired to 0 since this field is not valid for endpoint devices
14	Advanced Packet Switching — RO. Hardwired to 0 since this field is not valid for endpoint devices
13:8	Reserved
7:0	Port Arbitration Capability — RO. Hardwired to 0 since this field is not valid for endpoint devices

18.1.43 VCICTL—VCi Resource Control Register (Intel[®] High Definition Audio Controller—D27:F0)

Address Offset: 120h Attribute: R/W, RO
Default Value: 00000000h Size: 32 bits

Bit	Description
31	VCi Enable — R/W. 0 = VCi is disabled 1 = VCi is enabled Note: This bit is not reset on D3 _{HOT} to D0 transition; however, it is reset by PLTRST#.
30:27	Reserved.
26:24	VCi ID — R/W. This field assigns a VC ID to the VCi resource. This field is not used by the ICH6 hardware, but it is R/W to avoid confusing software.
23:20	Reserved.
19:17	Port Arbitration Select — RO. Hardwired to 0 since this field is not valid for endpoint devices
16	Load Port Arbitration Table — RO. Hardwired to 0 since this field is not valid for endpoint devices
15:8	Reserved.
7:0	TC/VCi Map — R/W, RO. This field indicates the TCs that are mapped to the VCi resource. Bit 0 is hardwired to 0 indicating that it cannot be mapped to VCi. Bits [7:1] are implemented as R/W bits. This field is not used by the ICH6 hardware, but it is R/W to avoid confusing software.

18.1.44 VCISTS—VCi Resource Status Register (Intel[®] High Definition Audio Controller—D27:F0)

Address Offset: 126h Attribute: RO
Default Value: 0000h Size: 16 bits

Bit	Description
15:2	Reserved.
1	VCi Negotiation Pending — RO. Does not apply. Hardwired to 0.
0	Port Arbitration Table Status — RO. Hardwired to 0 since this field is not valid for endpoint devices.

18.1.45 RCCAP—Root Complex Link Declaration Enhanced Capability Header Register (Intel[®] High Definition Audio Controller—D27:F0)

Address Offset: 130h Attribute: RO
Default Value: 00010005h Size: 32 bits

Bit	Description
31:20	Next Capability Offset — RO. Hardwired to 0 indicating this is the last capability.
19:16	Capability Version — RO. Hardwired to 1h.
15:0	PCI Express* Extended Capability ID — RO. Hardwired to 0005h.

18.1.46 ESD—Element Self Description Register (Intel® High Definition Audio Controller—D27:F0)

Address Offset: 134h Attribute: RO
Default Value: 05000100h Size: 32 bits

Bit	Description
31:24	Port Number — RO. Hardwired to 05h indicating that the Intel High Definition Audio controller is assigned as Port #5.
23:16	Component ID — RO. This field returns the value of the ESD.CID field of the chip configuration section. ESD.CID is programmed by BIOS.
15:8	Number of Link Entries — RO. The Intel High Definition Audio only connects to one device, the ICH6 egress port. Therefore this field reports a value of 1h.
7:4	Reserved.
3:0	Element Type (ELTYP) — RO. The Intel High Definition Audio controller is an integrated Root Complex Device. Therefore, the field reports a value of 0h.

18.1.47 L1DESC—Link 1 Description Register (Intel® High Definition Audio Controller—D27:F0)

Address Offset: 140h Attribute: RO
Default Value: 00000001h Size: 32 bits

Bit	Description
31:24	Target Port Number — RO. The Intel High Definition Audio controller targets the Intel® ICH6's RCRB Egress port, which is Port #0.
23:16	Target Component ID — RO. This field returns the value of the ESD.CID field of the chip configuration section. ESD.CID is programmed by BIOS.
15:2	Reserved.
1	Link Type — RO. Hardwired to 0 indicating Type 0.
0	Link Valid — RO. Hardwired to 1.

18.1.48 L1ADDL—Link 1 Lower Address Register (Intel® High Definition Audio Controller—D27:F0)

Address Offset: 148h Attribute: RO
Default Value: See Register Description Size: 32 bits

Bit	Description
31:14	Link 1 Lower Address — RO. Hardwired to match the RCBA register value in the PCI-LPC bridge (D31:F0:F0h).
13:0	Reserved.

18.1.49 L1ADDU—Link 1 Upper Address Register (Intel® High Definition Audio Controller—D27:F0)

Address Offset: 14Ch Attribute: RO
 Default Value: See Register Description Size: 32 bits

Bit	Description
31:0	Link 1 Upper Address — RO. Hardwired to match the RCBA register value in the PCI-LPC bridge (D31:F0:F0h).

18.2 Intel® High Definition Audio Memory Mapped Configuration Registers (Intel® High Definition Audio— D27:F0)

The base memory location for these memory mapped configuration registers is specified in the HDBAR register (D27:F0:offset 10h and D27:F0:offset 14h). The individual registers are then accessible at HDBAR + Offset as indicated in the following table.

These memory mapped registers must be accessed in byte, word, or DWord quantities.

Table 18-2. Intel® High Definition Audio PCI Register Address Map (Intel® High Definition Audio D27:F0) (Sheet 1 of 4)

HDBAR + Offset	Mnemonic	Register Name	Default	Access
00–01h	GCAP	Global Capabilities	4401h	RO
02h	VMIN	Minor Version	00h	RO
03h	VMAJ	Major Version	01h	RO
04–05h	OUTPAY	Output Payload Capability	003Ch	RO
06–07h	INPAY	Input Payload Capability	001Dh	RO
08–0Bh	GCTL	Global Control	00000000h	R/W
0C–0Dh	WAKEEN	Wake Enable	0000h	R/W
0E–0Fh	STATESTS	State Change Status	0000h	R/WC
10–11h	GSTS	Global Status	0000h	R/WC
20–23h	INTCTL	Interrupt Control	00000000h	R/W
24–27h	INTSTS	Interrupt Status	00000000h	RO
30–33h	WALCLK	Wall Clock Counter	00000000h	RO
34–37h	SSYNC	Stream Synchronization	00000000h	R/W
40–43h	CORB LBASE	CORB Lower Base Address	00000000h	R/W, RO
44–47h	CORB UBASE	CORB Upper Base Address	00000000h	R/W
48–49h	CORBWP	CORB Write Pointer	0000h	R/W
4A–4Bh	CORB RP	CORB Read Pointer	0000h	R/W
4Ch	CORBCTL	CORB Control	00h	R/W

**Table 18-2. Intel® High Definition Audio PCI Register Address Map
(Intel® High Definition Audio
D27:F0) (Sheet 2 of 4)**

HDBAR + Offset	Mnemonic	Register Name	Default	Access
4Dh	CORBST	CORB Status	00h	R/WC
4Eh	CORBSIZE	CORB Size	42h	RO
50–53h	RIRBLBASE	RIRB Lower Base Address	00000000h	R/W, RO
54–57h	RIRBUBASE	RIRB Upper Base Address	00000000h	R/W
58–59h	RIRBWP	RIRB Write Pointer	0000h	R/W, RO
5A–5Bh	RINTCNT	Response Interrupt Count	0000h	R/W
5Ch	RIRBCTL	RIRB Control	00h	R/W
5Dh	RIRBSTS	RIRB Status	00h	R/WC
5Eh	RIRBSIZE	RIRB Size	42h	RO
60–63h	IC	Immediate Command	00000000h	R/W
64–67h	IR	Immediate Response	00000000h	RO
68–69h	IRS	Immediate Command Status	0000h	R/W, R/WC
70–73h	DPLBASE	DMA Position Lower Base Address	00000000h	R/W, RO
74–77h	DPUBASE	DMA Position Upper Base Address	00000000h	R/W
80–82h	ISD0CTL	Input Stream Descriptor 0 (ISD0) Control	040000h	R/W, RO
83h	ISD0STS	ISD0 Status	00h	R/WC, RO
84–87h	ISD0LPIB	ISD0 Link Position in Buffer	00000000h	RO
88–8Bh	ISD0CBL	ISD0 Cyclic Buffer Length	00000000h	R/W
8C–8Dh	ISD0LVI	ISD0 Last Valid Index	0000h	R/W
8E–8F	ISD0FIFOW	ISD0 FIFO Watermark	0004h	R/W
90–91h	ISD0FIFOS	ISD0 FIFO Size	0077h	RO
92–93h	ISD0FMT	ISD0 Format	0000h	R/W
98–9Bh	ISD0BDPL	ISD0 Buffer Descriptor List Pointer-Lower Base Address	00000000h	R/W, RO
9C–9Fh	ISD0BDPU	ISD0 Buffer Description List Pointer-Upper Base Address	00000000h	R/W
A0–A2h	ISD1CTL	Input Stream Descriptor 1 (ISD01) Control	040000h	R/W, RO
A3h	ISD1STS	ISD1 Status	00h	R/WC, RO
A4–A7h	ISD1LPIB	ISD1 Link Position in Buffer	00000000h	RO
A8–ABh	ISD1CBL	ISD1 Cyclic Buffer Length	00000000h	R/W
AC–ADh	ISD1LVI	ISD1 Last Valid Index	0000h	R/W
AE–AFh	ISD1FIFOW	ISD1 FIFO Watermark	0004h	R/W
B0–B1h	ISD1FIFOS	ISD1 FIFO Size	0077h	RO
B2–B3h	ISD1FMT	ISD1 Format	0000h	R/W
B8–BBh	ISD1BDPL	ISD1 Buffer Descriptor List Pointer-Lower Base Address	00000000h	R/W, RO



Table 18-2. Intel® High Definition Audio PCI Register Address Map (Intel® High Definition Audio D27:F0) (Sheet 3 of 4)

HDBAR + Offset	Mnemonic	Register Name	Default	Access
BC–BFh	ISD1BDPU	ISD1 Buffer Description List Pointer-Upper Base Address	00000000h	R/W
C0–C2h	ISD2CTL	Input Stream Descriptor 2 (ISD2) Control	040000h	R/W, RO
C3h	ISD2STS	ISD2 Status	00h	R/WC, RO
C4–C7h	ISD2LPIB	ISD2 Link Position in Buffer	00000000h	RO
C8–CBh	ISD2CBL	ISD2 Cyclic Buffer Length	00000000h	R/W
CC–CDh	ISD2LVI	ISD2 Last Valid Index	0000h	R/W
CE–CFh	ISD1FIFOW	ISD1 FIFO Watermark	0004h	R/W
D0–D1h	ISD2FIFOS	ISD2 FIFO Size	0077h	RO
D2–D3h	ISD2FMT	ISD2 Format	0000h	R/W
D8–DBh	ISD2BDPL	ISD2 Buffer Descriptor List Pointer-Lower Base Address	00000000h	R/W, RO
DC–DFh	ISD2BDPU	ISD2 Buffer Description List Pointer-Upper Base Address	00000000h	R/W
E0–E2h	ISD3CTL	Input Stream Descriptor 3 (ISD3) Control	040000h	R/W, RO
E3h	ISD3STS	ISD3 Status	00h	R/WC, RO
E4–E7h	ISD3LPIB	ISD3 Link Position in Buffer	00000000h	RO
E8–EBh	ISD3CBL	ISD3 Cyclic Buffer Length	00000000h	R/W
EC–EDh	ISD3LVI	ISD3 Last Valid Index	0000h	R/W
EE–EFh	ISD3FIFOW	ISD3 FIFO Watermark	0004h	R/W
F0–F1h	ISD3FIFOS	ISD3 FIFO Size	0077h	RO
F2–F3h	ISD3FMT	ISD3 Format	0000h	R/W
F8–FBh	ISD3BDPL	ISD3 Buffer Descriptor List Pointer-Lower Base Address	00000000h	R/W, RO
FC–FFh	ISD3BDPU	ISD3 Buffer Description List Pointer-Upper Base Address	00000000h	R/W
100–102h	OSD0CTL	Output Stream Descriptor 0 (OSD0) Control	040000h	R/W, RO
103h	OSD0STS	OSD0 Status	00h	R/WC, RO
104–107h	OSD0LPIB	OSD0 Link Position in Buffer	00000000h	RO
108–10Bh	OSD0CBL	OSD0 Cyclic Buffer Length	00000000h	R/W
10C–10Dh	OSD0LVI	OSD0 Last Valid Index	0000h	R/W
10E–10Fh	OSD0FIFOW	OSD0 FIFO Watermark	0004h	R/W
110–111h	OSD0FIFOS	OSD0 FIFO Size	00BFh	R/W
112–113h	OSD0FMT	OSD0 Format	0000h	R/W
118–11Bh	OSD0BDPL	OSD0 Buffer Descriptor List Pointer-Lower Base Address	00000000h	R/W, RO
11C–11Fh	OSD0BDPU	OSD0 Buffer Description List Pointer-Upper Base Address	00000000h	R/W

**Table 18-2. Intel® High Definition Audio PCI Register Address Map
(Intel® High Definition Audio
D27:F0) (Sheet 4 of 4)**

HDBAR + Offset	Mnemonic	Register Name	Default	Access
120–122h	OSD1CTL	Output Stream Descriptor 1 (OSD1) Control	040000h	R/W, RO
123h	OSD1STS	OSD1 Status	00h	R/WC, RO
124–127h	OSD1LPIB	OSD1 Link Position in Buffer	00000000h	RO
128–12Bh	OSD1CBL	OSD1 Cyclic Buffer Length	00000000h	R/W
12C–12Dh	OSD1LVI	OSD1 Last Valid Index	0000h	R/W
12E–12Fh	OSD1FIFOW	OSD1 FIFO Watermark	0004h	R/W
130–131h	OSD1FIFOS	OSD1 FIFO Size	00BFh	R/W
132–133h	OSD1FMT	OSD1 Format	0000h	R/W
138–13Bh	OSD1BDPL	OSD1 Buffer Descriptor List Pointer-Lower Base Address	00000000h	R/W, RO
13C–13Fh	OSD1BDPU	OSD1 Buffer Description List Pointer-Upper Base Address	00000000h	R/W
140–142h	OSD2CTL	Output Stream Descriptor 2 (OSD2) Control	040000h	R/W, RO
143h	OSD2STS	OSD2 Status	00h	R/WC, RO
144–147h	OSD2LPIB	OSD2 Link Position in Buffer	00000000h	RO
148–14Bh	OSD2CBL	OSD2 Cyclic Buffer Length	00000000h	R/W
14C–14Dh	OSD2LVI	OSD2 Last Valid Index	0000h	R/W
14E–14Fh	OSD2FIFOW	OSD2 FIFO Watermark	0004h	R/W
150–151h	OSD2FIFOS	OSD2 FIFO Size	00BFh	R/W
152–153h	OSD2FMT	OSD2 Format	0000h	R/W
158–15Bh	OSD2BDPL	OSD2 Buffer Descriptor List Pointer-Lower Base Address	00000000h	R/W, RO
15C–15Fh	OSD2BDPU	OSD2 Buffer Description List Pointer-Upper Base Address	00000000h	R/W
160–162h	OSD3CTL	Output Stream Descriptor 3 (OSD3) Control	040000h	R/W, RO
163h	OSD3STS	OSD3 Status	00h	R/WC, RO
164–167h	OSD3LPIB	OSD3 Link Position in Buffer	00000000h	RO
168–16Bh	OSD3CBL	OSD3 Cyclic Buffer Length	00000000h	R/W
16C–16Dh	OSD3LVI	OSD3 Last Valid Index	0000h	R/W
16E–16Fh	OSD3FIFOW	OSD3 FIFO Watermark	0004h	R/W
170–171h	OSD3FIFOS	OSD3 FIFO Size	00BFh	R/W
172–173h	OSD3FMT	OSD3 Format	0000h	R/W
178–17Bh	OSD3BDPL	OSD3 Buffer Descriptor List Pointer-Lower Base Address	00000000h	R/W, RO
17C–17Fh	OSD3BDPU	OSD3 Buffer Description List Pointer-Upper Base Address	00000000h	R/W



18.2.1 GCAP—Global Capabilities Register (Intel® High Definition Audio Controller—D27:F0)

Memory Address: HDBAR + 00h Attribute: RO
Default Value: 4401h Size: 16 bits

Bit	Description
15:12	Number of Output Stream Supported — RO. Hardwired to 0100b indicating that the ICH6 Intel High Definition Audio controller supports 4 output streams.
11:8	Number of Input Stream Supported — RO. Hardwired to 0100b indicating that the ICH6 Intel High Definition Audio controller supports 4 input streams.
7:3	Number of Bidirectional Stream Supported — RO. Hardwired to 0 indicating that the ICH6 Intel High Definition Audio controller supports 0 bidirectional stream.
2	Reserved.
1	Number of Serial Data Out Signals — RO. Hardwired to 0 indicating that the ICH6 Intel High Definition Audio controller supports 1 serial data output signal.
0	64-bit Address Supported — RO. Hardwired to 1b indicating that the ICH6 Intel High Definition Audio controller supports 64-bit addressing for BDL addresses, data buffer addressees, and command buffer addresses.

18.2.2 VMIN—Minor Version Register (Intel® High Definition Audio Controller—D27:F0)

Memory Address: HDBAR + 02h Attribute: RO
Default Value: 00h Size: 8 bits

Bit	Description
7:0	Minor Version — RO. Hardwired to 0 indicating that the Intel® ICH6 supports minor revision number 00h of the Intel High Definition Audio specification.

18.2.3 VMAJ—Major Version Register (Intel® High Definition Audio Controller—D27:F0)

Memory Address: HDBAR + 03h Attribute: RO
Default Value: 01h Size: 8 bits

Bit	Description
7:0	Major Version — RO. Hardwired to 01h indicating that the Intel® ICH6 supports major revision number 1 of the Intel High Definition Audio specification.

18.2.4 OUTPAY—Output Payload Capability Register (Intel® High Definition Audio Controller—D27:F0)

Memory Address: HDAR + 04h
Default Value: 003Ch

Attribute: RO
Size: 16 bits

Bit	Description
15:7	Reserved.
6:0	<p>Output Payload Capability — RO. Hardwired to 3Ch indicating 60 word payload.</p> <p>This field indicates the total output payload available on the link. This does not include bandwidth used for command and control. This measurement is in 16-bit word quantities per 48 MHz frame. The default link clock of 24.000 MHz (the data is double pumped) provides 1000 bits per frame, or 62.5 words in total. 40 bits are used for command and control, leaving 60 words available for data payload.</p> <p>00h = 0 word 01h = 1 word payload. FFh = 256 word payload.</p>

18.2.5 INPAY—Input Payload Capability Register (Intel® High Definition Audio Controller—D27:F0)

Memory Address: HDBAR + 06h
Default Value: 001Dh

Attribute: RO
Size: 16 bits

Bit	Description
15:7	Reserved.
6:0	<p>Input Payload Capability — RO. Hardwired to 1Dh indicating 29 word payload.</p> <p>This field indicates the total output payload available on the link. This does not include bandwidth used for response. This measurement is in 16-bit word quantities per 48 MHz frame. The default link clock of 24.000 MHz provides 500 bits per frame, or 31.25 words in total. 36 bits are used for response, leaving 29 words available for data payload.</p> <p>00h = 0 word 01h = 1 word payload. FFh = 256 word payload.</p>

18.2.6 GCTL—Global Control Register (Intel® High Definition Audio Controller—D27:F0)

Memory Address: HDBAR + 08h
 Default Value: 00000000h

Attribute: R/W
 Size: 32 bits

Bit	Description
31:9	Reserved.
8	<p>Accept Unsolicited Response Enable — R/W.</p> <p>0 = Unsolicited responses from the codecs are not accepted. 1 = Unsolicited response from the codecs are accepted by the controller and placed into the Response Input Ring Buffer.</p>
7:2	Reserved.
1	<p>Flush Control — R/W. Writing a 1 to this bit initiates a flush. When the flush completion is received by the controller, hardware sets the Flush Status bit and clears this Flush Control bit. Before a flush cycle is initiated, the DMA Position Buffer must be programmed with a valid memory address by software, but the DMA Position Buffer bit 0 needs not be set to enable the position reporting mechanism. Also, all streams must be stopped (the associated RUN bit must be 0).</p> <p>When the flush is initiated, the controller will flush the pipelines to memory to guarantee that the hardware is ready to transition to a D3 state. Setting this bit is not a critical step in the power state transition if the content of the FIFOs is not critical.</p>
0	<p>Controller Reset # (CRST#) — R/W.</p> <p>0 = Writing a 0 to this bit causes the Intel High Definition Audio controller to be reset. All state machines, FIFOs and non-resume well memory mapped configuration registers (not PCI configuration registers) in the controller will be reset. The Intel High Definition Audio link RESET# signal will be asserted, and all other link signals will be driven to their default values. After the hardware has completed sequencing into the reset state, it will report a 0 in this bit. Software must read a 0 from this bit to verify the controller is in reset.</p> <p>1 = Writing a 1 to this bit causes the controller to exit its reset state and de-assert the Intel High Definition Audio link RESET# signal. Software is responsible for setting/clearing this bit such that the minimum Intel High Definition Audio link RESET# signal assertion pulse width specification is met. When the controller hardware is ready to begin operation, it will report a 1 in this bit. Software must read a 1 from this bit before accessing any controller registers. This bit defaults to a 0 after Hardware reset, therefore, software needs to write a 1 to this bit to begin operation.</p> <p>NOTES:</p> <ol style="list-style-type: none"> 1. The CORB/RIRB RUN bits and all stream RUN bits must be verified cleared to 0 before writing a 0 to this bit in order to assure a clean re-start. 2. When setting or clearing this bit, software must ensure that minimum link timing requirements (minimum RESET# assertion time, etc.) are met. 3. When this bit is 0 indicating that the controller is in reset, writes to all Intel High Definition Audio memory mapped registers are ignored as if the device is not present. The only exception is this register itself. The Global Control register is write-able as a DWord, Word, or Byte even when CRST# (this bit) is 0 if the byte enable for the byte containing the CRST# bit (Byte Enable 0) is active. If Byte Enable 0 is not active, writes to the Global Control register will be ignored when CRST# is 0. When CRST# is 0, reads to Intel High Definition Audio memory mapped registers will return their default value except for registers that are not reset with PLTRST# or on a D3_{HOT} to D0 transition.

18.2.7 WAKEEN—Wake Enable Register (Intel® High Definition Audio Controller—D27:F0)

Memory Address: HDBAR + 0Ch Attribute: R/W
 Default Value: 0000h Size: 16 bits

Bit	Description
15:3	Reserved.
2:0	<p>SDIN Wake Enable Flags — R/W. These bits control which SDI signal(s) may generate a wake event. A 1b in the bit mask indicates that the associated SDIN signal is enabled to generate a wake.</p> <p>Bit 0 is used for SDI[0] Bit 1 is used for SDI[1] Bit 2 is used for SDI[2]</p> <p>NOTE: These bits are in the resume well and only cleared on a power on reset. Software must not make assumptions about the reset state of these bits and must set them appropriately.</p>

18.2.8 STATESTS—State Change Status Register (Intel® High Definition Audio Controller—D27:F0)

Memory Address: HDBAR + 0Eh Attribute: R/WC
 Default Value: 0000h Size: 16 bits

Bit	Description
15:3	Reserved.
2:0	<p>SDIN State Change Status Flags — R/WC. Flag bits that indicate which SDI signal(s) received a state change event. The bits are cleared by writing 1s to them.</p> <p>Bit 0 = SDI[0] Bit 1 = SDI[1] Bit 2 = SDI[2]</p> <p>NOTE: These bits are in the resume well and only cleared on a power on reset. Software must not make assumptions about the reset state of these bits and must set them appropriately.</p>

18.2.9 GSTS—Global Status Register (Intel® High Definition Audio Controller—D27:F0)

Memory Address: HDBAR + 10h Attribute: R/WC
 Default Value: 0000h Size: 16 bits

Bit	Description
15:2	Reserved.
1	<p>Flush Status — R/WC. This bit is set to 1 by hardware to indicate that the flush cycle initiated when the Flush Control bit (HDBAR + 08h, bit 1) was set has completed. Software must write a 1 to clear this bit before the next time the Flush Control bit is set to clear the bit.</p>
0	Reserved.



18.2.10 INTCTL—Interrupt Control Register (Intel® High Definition Audio Controller—D27:F0)

Memory Address: HDBAR + 20h
Default Value: 00000000h

Attribute: R/W
Size: 32 bits

Bit	Description
31	<p>Global Interrupt Enable (GIE) — R/W. Global bit to enable device interrupt generation. When set to 1, the Intel High Definition Audio function is enabled to generate an interrupt. This control is in addition to any bits in the bus specific address space, such as the Interrupt Enable bit in the PCI configuration space.</p> <p>NOTE: This bit is not affected by the D3_{HOT} to D0 transition.</p>
30	<p>Controller Interrupt Enable (CIE) — R/W. Enables the general interrupt for controller functions. When set to 1, the controller generates an interrupt when the corresponding status bit gets set due to a Response Interrupt, a Response Buffer Overrun, and State Change events.</p> <p>NOTE: This bit is not affected by the D3_{HOT} to D0 transition.</p>
29:8	Reserved
7:0	<p>Stream Interrupt Enable (SIE) — R/W. When set to 1, the individual streams are enabled to generate an interrupt when the corresponding status bits get set.</p> <p>A stream interrupt will be caused as a result of a buffer with IOC = 1 in the BDL entry being completed, or as a result of a FIFO error (underrun or overrun) occurring. Control over the generation of each of these sources is in the associated Stream Descriptor.</p> <p>The streams are numbered and the SIE bits assigned sequentially, based on their order in the register set.</p> <p>Bit 0: input stream 1 Bit 1: input stream 2 Bit 2: input stream 3 Bit 3: input stream 4 Bit 4: output stream 1 Bit 5: output stream 2 Bit 6: output stream 3 Bit 7: output stream 4</p>

18.2.11 INTSTS—Interrupt Status Register (Intel® High Definition Audio Controller—D27:F0)

Memory Address: HDBAR + 24h
Default Value: 00000000h

Attribute: RO
Size: 32 bits

Bit	Description
31	Global Interrupt Status (GIS) — RO. This bit is an OR of all the interrupt status bits in this register. NOTE: This bit is not affected by the D3 _{HOT} to D0 transition.
30	Controller Interrupt Status (CIS) — RO. Status of general controller interrupt. 1 = Indicates that an interrupt condition occurred due to a Response Interrupt, a Response Buffer Overrun Interrupt, or a SDIN state change event. The exact cause can be determined by interrogating other registers. This bit is an OR of all of the stated interrupt status bits for this register. NOTES: 1. This bit is set regardless of the state of the corresponding interrupt enable bit, but a hardware interrupt will not be generated unless the corresponding enable bit is set. 2. This bit is not affected by the D3 _{HOT} to D0 transition.
29:8	Reserved
7:0	Stream Interrupt Status (SIS) — RO. 1 = Indicates that an interrupt condition occurred on the corresponding stream. This bit is an OR of all of the stream's interrupt status bits. NOTE: These bits are set regardless of the state of the corresponding interrupt enable bits. The streams are numbered and the SIE bits assigned sequentially, based on their order in the register set. Bit 0: input stream 1 Bit 1: input stream 2 Bit 2: input stream 3 Bit 3: input stream 4 Bit 4: output stream 1 Bit 5: output stream 2 Bit 6: output stream 3 Bit 7: output stream 4

18.2.12 WALCLK—Wall Clock Counter Register (Intel® High Definition Audio Controller—D27:F0)

Memory Address: HDBAR + 30h
Default Value: 00000000h

Attribute: RO
Size: 32 bits

Bit	Description
31:0	Wall Clock Counter — RO. 32 bit counter that is incremented on each link BCLK period and rolls over from FFFF FFFFh to 0000 0000h. This counter will roll over to 0 with a period of approximately 179 seconds. This counter is enabled while the BCLK bit is set to 1. Software uses this counter to synchronize between multiple controllers. Will be reset on controller reset.



18.2.13 SSYNC—Stream Synchronization Register (Intel® High Definition Audio Controller—D27:F0)

Memory Address: HDBAR + 34h
Default Value: 00000000h

Attribute: R/W
Size: 32 bits

Bit	Description
31:8	Reserved
7:0	<p>Stream Synchronization (SSYNC) — R/W. When set to 1, these bits block data from being sent on or received from the link. Each bit controls the associated stream descriptor (i.e. bit 0 corresponds to the first stream descriptor, etc.)</p> <p>To synchronously start a set of DMA engines, these bits are first set to 1. The RUN bits for the associated stream descriptors are then set to 1 to start the DMA engines. When all streams are ready (FIFORDY =1), the associated SSYNC bits can all be set to 0 at the same time, and transmission or reception of bits to or from the link will begin together at the start of the next full link frame.</p> <p>To synchronously stop the streams, first these bits are set, and then the individual RUN bits in the stream descriptor are cleared by software.</p> <p>If synchronization is not desired, these bits may be left as 0, and the stream will simply begin running normally when the stream's RUN bit is set.</p> <p>The streams are numbered and the SIE bits assigned sequentially, based on their order in the register set.</p> <p>Bit 0: input stream 1 Bit 1: input stream 2 Bit 2: input stream 3 Bit 3: input stream 4 Bit 4: output stream 1 Bit 5: output stream 2</p>

18.2.14 CORBLBASE—CORB Lower Base Address Register (Intel® High Definition Audio Controller—D27:F0)

Memory Address: HDBAR + 40h Attribute: R/W, RO
 Default Value: 00000000h Size: 32 bits

Bit	Description
31:7	CORB Lower Base Address — R/W. Lower address of the Command Output Ring Buffer, allowing the CORB base address to be assigned on any 128-B boundary. This register field must not be written when the DMA engine is running or the DMA transfer may be corrupted.
6:0	CORB Lower Base Unimplemented Bits — RO. Hardwired to 0. This required the CORB to be allocated with 128B granularity to allow for cache line fetch optimizations.

18.2.15 CORBUBASE—CORB Upper Base Address Register (Intel® High Definition Audio Controller—D27:F0)

Memory Address: HDBAR + 44h Attribute: R/W
 Default Value: 00000000h DWord Size: 32 bits

Bit	Description
31:0	CORB Upper Base Address — R/W. Upper 32 bits of the address of the Command Output Ring buffer. This register field must not be written when the DMA engine is running or the DMA transfer may be corrupted.

18.2.16 CORBRP—CORB Write Pointer Register (Intel® High Definition Audio Controller—D27:F0)

Memory Address: HDBAR + 48h Attribute: R/W
 Default Value: 0000h Size: 16 bits

Bit	Description
15:8	Reserved.
7:0	CORB Write Pointer — R/W. Software writes the last valid CORB entry offset into this field in DWord granularity. The DMA engine fetches commands from the CORB until the Read Pointer matches the Write Pointer. Supports 256 CORB entries (256x4B = 1KB). This register field may be written while the DMA engine is running.

18.2.17 CORBRP—CORB Read Pointer Register (Intel® High Definition Audio Controller—D27:F0)

Memory Address: HDBAR + 4Ah Attribute: R/W
Default Value: 0000h Size: 16 bits

Bit	Description
15	CORB Read Pointer Reset — R/W. Software writes a 1 to this bit to reset the CORB Read Pointer to 0 and clear any residual prefetched commands in the CORB hardware buffer within the Intel High Definition Audio controller. The hardware will physically update this bit to 1 when the CORB Pointer reset is complete. Software must read a 1 to verify that the reset completed correctly. Software must clear this bit back to 0 and read back the 0 to verify that the clear completed correctly. The CORB DMA engine must be stopped prior to resetting the Read Pointer or else DMA transfer may be corrupted.
14:8	Reserved.
7:0	CORB Read Pointer — R/W. Software reads this field to determine how many commands it can write to the CORB without over-running. The value read indicates the CORB Read Pointer offset in DWord granularity. The offset entry read from this field has been successfully fetched by the DMA controller and may be over-written by software. Supports 256 CORB entries (256x4B = 1KB). This register field may be ready while the DMA engine is running.

18.2.18 CORBCTL—CORB Control Register (Intel® High Definition Audio Controller—D27:F0)

Memory Address: HDBAR + 4Ch Attribute: R/W
Default Value: 00h Size: 8 bits

Bit	Description
7:2	Reserved.
1	Enable CORB DMA Engine — R/W. 0 = DMA stop 1 = DMA run After software writes a 0 to this bit, the hardware may not stop immediately. The hardware will physically update the bit to 0 when the DMA engine is truly stopped. Software must read a 0 from this bit to verify that the DMA engine is truly stopped.
0	CORB Memory Error Interrupt Enable — R/W. If this bit is set the controller will generate an interrupt if the CMEI status bit (HDBAR + 4Dh: bit 0) is set.

18.2.19 CORBST—CORB Status Register (Intel® High Definition Audio Controller—D27:F0)

Memory Address: HDBAR + 4Dh Attribute: R/WC
 Default Value: 00h Size: 8 bits

Bit	Description
7:1	Reserved.
0	CORB Memory Error Indication (CMEI) — R/WC. If this bit is set, the controller has detected an error in the path way between the controller and memory. This may be an ECC bit error or any other type of detectable data error which renders the command data fetched invalid. Software can clear this bit by writing a 1 to it. However, this type of error leaves the audio subsystem in an unviable state and typically required a controller reset by writing a 0 to the Controller Reset # bit (HDBAR + 08h: bit 0).

18.2.20 CORBSIZE—CORB Size Register (Intel® High Definition Audio Controller—D27:F0)

Memory Address: HDBAR + 4Eh Attribute: RO
 Default Value: 42h Size: 8 bits

Bit	Description
7:4	CORB Size Capability — RO. Hardwired to 0100b indicating that the ICH6 only supports a CORB size of 256 CORB entries (1024B)
3:2	Reserved.
1:0	CORB Size — RO. Hardwired to 10b which sets the CORB size to 256 entries (1024B)

18.2.21 RIRLBASE—RIRB Lower Base Address Register (Intel® High Definition Audio Controller—D27:F0)

Memory Address: HDBAR + 50h Attribute: R/W, RO
 Default Value: 00000000h Size: 32 bits

Bit	Description
31:7	CORB Lower Base Address — R/W. Lower address of the Response Input Ring Buffer, allowing the RIRB base address to be assigned on any 128-B boundary. This register field must not be written when the DMA engine is running or the DMA transfer may be corrupted.
6:0	RIRB Lower Base Unimplemented Bits — RO. Hardwired to 0. This required the RIRB to be allocated with 128-B granularity to allow for cache line fetch optimizations.

18.2.25 RIRBCTL—RIRB Control Register (Intel® High Definition Audio Controller—D27:F0)

Memory Address: HDBAR + 5Ch Attribute: R/W
 Default Value: 00h Size: 8 bits

Bit	Description
7:3	Reserved.
2	Response Overrun Interrupt Control — R/W. If this bit is set, the hardware will generate an interrupt when the Response Overrun Interrupt Status bit (HDBAR + 5Dh: bit 2) is set.
1	Enable RIRB DMA Engine — R/W. 0 = DMA stop 1 = DMA run After software writes a 0 to this bit, the hardware may not stop immediately. The hardware will physically update the bit to 0 when the DMA engine is truly stopped. Software must read a 0 from this bit to verify that the DMA engine is truly stopped.
0	Response Interrupt Control — R/W. 0 = Disable Interrupt 1 = Generate an interrupt after N number of responses are sent to the RIRB buffer OR when an empty Response slot is encountered on all SDI[x] inputs (whichever occurs first). The N counter is reset when the interrupt is generated.

18.2.26 RIRBSTS—RIRB Status Register (Intel® High Definition Audio Controller—D27:F0)

Memory Address: HDBAR + 5Dh Attribute: R/WC
 Default Value: 00h Size: 8 bits

Bit	Description
7:3	Reserved.
2	Response Overrun Interrupt Status — R/WC. Software sets this bit to 1 when the RIRB DMA engine is not able to write the incoming responses to memory before additional incoming responses overrun the internal FIFO. When the overrun occurs, the hardware will drop the responses which overrun the buffer. An interrupt may be generated if the Response Overrun Interrupt Control bit is set. Note that this status bit is set even if an interrupt is not enabled for this event. Software clears this bit by writing a 1 to it.
1	Reserved.
0	Response Interrupt — R/WC. Hardware sets this bit to 1 when an interrupt has been generated after N number of Responses are sent to the RIRB buffer OR when an empty Response slot is encountered on all SDI[x] inputs (whichever occurs first). Note that this status bit is set even if an interrupt is not enabled for this event. Software clears this bit by writing a 1 to it.



18.2.27 RIRBSIZE—RIRB Size Register (Intel® High Definition Audio Controller—D27:F0)

Memory Address: HDBAR + 5Eh Attribute: RO
Default Value: 42h Size: 8 bits

Bit	Description
7:4	RIRB Size Capability — RO. Hardwired to 0100b indicating that the ICH6 only supports a RIRB size of 256 RIRB entries (2048B)
3:2	Reserved.
1:0	RIRB Size — RO. Hardwired to 10b which sets the CORB size to 256 entries (2048B)

18.2.28 IC—Immediate Command Register (Intel® High Definition Audio Controller—D27:F0)

Memory Address: HDBAR + 60h Attribute: R/W
Default Value: 00000000h Size: 32 bits

Bit	Description
31:0	Immediate Command Write — R/W. The command to be sent to the codec via the Immediate Command mechanism is written to this register. The command stored in this register is sent out over the link during the next available frame after a 1 is written to the ICB bit (HDBAR + 68h: bit 0)

18.2.29 IR—Immediate Response Register (Intel® High Definition Audio Controller—D27:F0)

Memory Address: HDBAR + 64h Attribute: RO
Default Value: 00000000h Size: 32 bits

Bit	Description
31:0	Immediate Response Read (IRR) — RO. This register contains the response received from a codec resulting from a command sent via the Immediate Command mechanism. If multiple codecs responded in the same time, there is no guarantee as to which response will be latched. Therefore, broadcast-type commands must not be issued via the Immediate Command mechanism.

18.2.30 IRS—Immediate Command Status Register (Intel® High Definition Audio Controller—D27:F0)

Memory Address: HDBAR + 68h
Default Value: 0000h

Attribute: R/W, R/WC
Size: 16 bits

Bit	Description
15:2	Reserved.
1	<p>Immediate Result Valid (IRV) — R/WC. This bit is set to 1 by hardware when a new response is latched into the Immediate Response register (HDBAR + 64). This is a status flag indicating that software may read the response from the Immediate Response register.</p> <p>Software must clear this bit by writing a 1 to it before issuing a new command so that the software may determine when a new response has arrived.</p>
0	<p>Immediate Command Busy (ICB) — R/W. When this bit is read as 0, it indicates that a new command may be issued using the Immediate Command mechanism. When this bit transitions from a 0 to a 1 (via software writing a 1), the controller issues the command currently stored in the Immediate Command register to the codec over the link. When the corresponding response is latched into the Immediate Response register, the controller hardware sets the IRV flag and clears the ICB bit back to 0.</p> <p>NOTE: An Immediate Command must not be issued while the CORB/RIRB mechanism is operating, otherwise the responses conflict. This must be enforced by software.</p>

18.2.31 DPLBASE—DMA Position Lower Base Address Register (Intel® High Definition Audio Controller—D27:F0)

Memory Address: HDBAR + 70h
Default Value: 00000000h

Attribute: R/W, RO
Size: 32 bits

Bit	Description
31:7	<p>DMA Position Lower Base Address — R/W. Lower 32 bits of the DMA Position Buffer Base Address. This register field must not be written when any DMA engine is running or the DMA transfer may be corrupted. This same address is used by the Flush Control and must be programmed with a valid value before the Flush Control bit (HDBAR+08h:bit 1) is set.</p>
6:1	<p>DMA Position Lower Base Unimplemented bits — RO. Hardwired to 0 to force the 128-byte buffer alignment for cache line write optimizations.</p>
0	<p>DMA Position Buffer Enable — R/W.</p> <p>When this bit is set to 1, the controller will write the DMA positions of each of the DMA engines to the buffer in the main memory periodically (typically once per frame). Software can use this value to know what data in memory is valid data.</p>

18.2.32 DPUBASE—DMA Position Upper Base Address Register (Intel® High Definition Audio Controller—D27:F0)

Memory Address: HDBAR + 74h Attribute: R/W
 Default Value: 00000000h Size: 32 bits

Bit	Description
31:0	DMA Position Upper Base Address — R/W. Upper 32 bits of the DMA Position Buffer Base Address. This register field must not be written when any DMA engine is running or the DMA transfer may be corrupted.

18.2.33 SDCTL—Stream Descriptor Control Register (Intel® High Definition Audio Controller—D27:F0)

Memory Address: Input Stream[0]: HDBAR + 80h Attribute:R/W, RO
 Input Stream[1]: HDBAR + A0h
 Input Stream[2]: HDBAR + C0h
 Input Stream[3]: HDBAR + E0h
 Output Stream[0]: HDBAR + 100h
 Output Stream[1]: HDBAR + 120h
 Output Stream[2]: HDBAR + 140h
 Output Stream[3]: HDBAR + 160h

Default Value: 040000h Size:24 bits

Bit	Description
23:20	Stream Number — R/W. This value reflect the Tag associated with the data being transferred on the link. When data controlled by this descriptor is sent out over the link, it will have its stream number encoded on the SYNC signal. When an input stream is detected on any of the SDI signals that match this value, the data samples are loaded into FIFO associated with this descriptor. Note that while a single SDI input may contain data from more than one stream number, two different SDI inputs may not be configured with the same stream number. 0000 = Reserved 0001 = Stream 1 1110 = Stream 14 1111 = Stream 15
19	Bidirectional Direction Control — RO. This bit is only meaningful for bidirectional streams; therefore, this bit is hardwired to 0.
18	Traffic Priority — RO. Hardwired to 1 indicating that all streams will use VC1 if it is enabled through the PCI Express* registers.
17:16	Stripe Control — RO. This bit is only meaningful for input streams; therefore, this bit is hardwired to 0.
15:5	Reserved
4	Descriptor Error Interrupt Enable — R/W. 0 = Disable 1 = An interrupt is generated when the Descriptor Error Status bit is set.

Bit	Description
3	FIFO Error Interrupt Enable — R/W. This bit controls whether the occurrence of a FIFO error (overrun for input or underrun for output) will cause an interrupt or not. If this bit is not set, bit 3 in the Status register will be set, but the interrupt will not occur. Either way, the samples will be dropped.
2	Interrupt on Completion Enable — R/W. This bit controls whether or not an interrupt occurs when a buffer completes with the IOC bit set in its descriptor. If this bit is not set, bit 2 in the Status register will be set, but the interrupt will not occur.
1	Stream Run (RUN) — R/W. 0 = When cleared to 0, the DMA engine associated with this input stream will be disabled. The hardware will report a 0 in this bit when the DMA engine is actually stopped. Software must read a 0 from this bit before modifying related control registers or restarting the DMA engine. 1 = When set to 1, the DMA engine associated with this input stream will be enabled to transfer data from the FIFO to the main memory. The SSYNC bit must also be cleared in order for the DMA engine to run. For output streams, the cadence generator is reset whenever the RUN bit is set.
0	Stream Reset (SRST) — R/W. 0 = Writing a 0 causes the corresponding stream to exit reset. When the stream hardware is ready to begin operation, it will report a 0 in this bit. Software must read a 0 from this bit before accessing any of the stream registers. 1 = Writing a 1 causes the corresponding stream to be reset. The Stream Descriptor registers (except the SRST bit itself) and FIFO's for the corresponding stream are reset. After the stream hardware has completed sequencing into the reset state, it will report a 1 in this bit. Software must read a 1 from this bit to verify that the stream is in reset. The RUN bit must be cleared before SRST is asserted.

18.2.34 SDSTS—Stream Descriptor Status Register (Intel[®] High Definition Audio Controller—D27:F0)

Memory Address: Input Stream[0]: HDBAR + 83h Attribute:R/WC, RO
 Input Stream[1]: HDBAR + A3h
 Input Stream[2]: HDBAR + C3h
 Input Stream[3]: HDBAR + E3h
 Output Stream[0]: HDBAR + 103h
 Output Stream[1]: HDBAR + 123h
 Output Stream[2]: HDBAR + 143h
 Output Stream[3]: HDBAR + 163h

Default Value: 00h Size: 8 bits

Bit	Description
7:6	Reserved.
5	FIFO Ready (FIFORDY) — RO. For output streams, the controller hardware will set this bit to 1 while the output DMA FIFO contains enough data to maintain the stream on the link. This bit defaults to 0 on reset because the FIFO is cleared on a reset. For input streams, the controller hardware will set this bit to 1 when a valid descriptor is loaded and the engine is ready for the RUN bit to be set.
4	Descriptor Error — R/WC. When set, this bit indicates that a serious error occurred during the fetch of a descriptor. This could be a result of a Master Abort, a parity or ECC error on the bus, or any other error which renders the current Buffer Descriptor or Buffer Descriptor list useless. This error is treated as a fatal stream error, as the stream cannot continue running. The RUN bit will be cleared and the stream will stopped. Software may attempt to restart the stream engine after addressing the cause of the error and writing a 1 to this bit to clear it.
3	FIFO Error — R/WC. This bit is set when a FIFO error occurs. This bit is set even if an interrupt is not enabled. The bit is cleared by writing a 1 to it. For an input stream, this indicates a FIFO overrun occurring while the RUN bit is set. When this happens, the FIFO pointers do not increment and the incoming data is not written into the FIFO, thereby being lost. For an output stream, this indicates a FIFO underrun when there are still buffers to send. The hardware should not transmit anything on the link for the associated stream if there is not valid data to send.
2	Buffer Completion Interrupt Status — R/WC. This bit is set to 1 by the hardware after the last sample of a buffer has been processed, AND if the Interrupt on Completion bit is set in the command byte of the buffer descriptor. It remains active until software clears it by writing a 1 to it.
1:0	Reserved.

18.2.35 SDLPIB—Stream Descriptor Link Position in Buffer Register (Intel[®] High Definition Audio Controller—D27:F0)

Memory Address: Input Stream[0]: HDBAR + 84h Attribute:RO
Input Stream[1]: HDBAR + A4h
Input Stream[2]: HDBAR + C4h
Input Stream[3]: HDBAR + E4h
Output Stream[0]: HDBAR + 104h
Output Stream[1]: HDBAR + 124h
Output Stream[2]: HDBAR + 144h
Output Stream[3]: HDBAR + 164h

Default Value: 00000000h Size: 32 bits

Bit	Description
31:0	Link Position in Buffer — RO. Indicates the number of bytes that have been received off the link. This register will count from 0 to the value in the Cyclic Buffer Length register and then wrap to 0.

18.2.36 SDCBL—Stream Descriptor Cyclic Buffer Length Register (Intel[®] High Definition Audio Controller—D27:F0)

Memory Address: Input Stream[0]: HDBAR + 88h Attribute:R/W
Input Stream[1]: HDBAR + A8h
Input Stream[2]: HDBAR + C8h
Input Stream[3]: HDBAR + E8h
Output Stream[0]: HDBAR + 108h
Output Stream[1]: HDBAR + 128h
Output Stream[2]: HDBAR + 148h
Output Stream[3]: HDBAR + 168h

Default Value: 00000000h Size: 32 bits

Bit	Description
31:0	Cyclic Buffer Length — R/W. Indicates the number of bytes in the complete cyclic buffer. This register represents an integer number of samples. Link Position in Buffer will be reset when it reaches this value. Software may only write to this register after Global Reset, Controller Reset, or Stream Reset has occurred. This value should be only modified when the RUN bit is 0. Once the RUN bit has been set to enable the engine, software must not write to this register until after the next reset is asserted, or transfer may be corrupted.

18.2.37 SDLVI—Stream Descriptor Last Valid Index Register (Intel® High Definition Audio Controller—D27:F0)

Memory Address: Input Stream[0]: HDBAR + 8Ch Attribute:R/W
 Input Stream[1]: HDBAR + ACh
 Input Stream[2]: HDBAR + CCh
 Input Stream[3]: HDBAR + ECh
 Output Stream[0]: HDBAR + 10Ch
 Output Stream[1]: HDBAR + 12Ch
 Output Stream[2]: HDBAR + 14Ch
 Output Stream[3]: HDBAR + 16Ch

Default Value: 0000h Size: 16 bits

Bit	Description
15:8	Reserved.
7:0	<p>Last Valid Index — R/W. The value written to this register indicates the index for the last valid Buffer Descriptor in BDL. After the controller has processed this descriptor, it will wrap back to the first descriptor in the list and continue processing.</p> <p>This field must be at least 1, i.e. there must be at least 2 valid entries in the buffer descriptor list before DMA operations can begin.</p> <p>This value should only modified when the RUN bit is 0.</p>

18.2.38 SDFIFOW—Stream Descriptor FIFO Watermark Register (Intel® High Definition Audio Controller—D27:F0)

Memory Address: Input Stream[0]: HDBAR + 8Eh Attribute:R/W
 Input Stream[1]: HDBAR + AEh
 Input Stream[2]: HDBAR + CEh
 Input Stream[3]: HDBAR + EEh
 Output Stream[0]: HDBAR + 10Eh
 Output Stream[1]: HDBAR + 12Eh
 Output Stream[2]: HDBAR + 14Eh
 Output Stream[3]: HDBAR + 16Eh

Default Value: 0004h Size: 16 bits

Bit	Description
15:3	Reserved.
2:0	<p>FIFO Watermark (FIFOW) — R/W. Indicates the minimum number of bytes accumulated/free in the FIFO before the controller will start a fetch/eviction of data.</p> <p>010 = 8B 011 = 16B 100 = 32B (Default) Others = Unsupported</p> <p>NOTES:</p> <ol style="list-style-type: none"> When the bit field is programmed to an unsupported size, the hardware sets itself to the default value. Software must read the bit field to test if the value is supported after setting the bit field.

18.2.39 SDFIFOS—Stream Descriptor FIFO Size Register (Intel® High Definition Audio Controller—D27:F0)

Memory Address: Input Stream[0]: HDBAR + 90h Attribute:Input: RO
 Input Stream[1]: HDBAR + B0h Output: R/W
 Input Stream[2]: HDBAR + D0h
 Input Stream[3]: HDBAR + F0h
 Output Stream[0]: HDBAR + 110h
 Output Stream[1]: HDBAR + 130h
 Output Stream[2]: HDBAR + 150h
 Output Stream[3]: HDBAR + 170h

Default Value: Input Stream: 0077h Size: 16 bits
 Output Stream: 00BFh

Bit	Description																				
15:8	Reserved.																				
7:0	<p>FIFO Size — RO (Input stream), R/W (Output stream). Indicates the maximum number of bytes that could be fetched by the controller at one time. This is the maximum number of bytes that may have been DMA'd into memory but not yet transmitted on the link, and is also the maximum possible value that the PICB count will increase by at one time.</p> <p>The value in this field is different for input and output streams. It is also dependent on the Bits per Samples setting for the corresponding stream. Following are the values read/written from/to this register for input and output streams, and for non-padded and padded bit formats:</p> <p><i>Output Stream R/W value:</i></p> <table border="1"> <thead> <tr> <th>Value</th> <th>Output Streams</th> </tr> </thead> <tbody> <tr> <td>0Fh = 16B</td> <td>8, 16, 20, 24, or 32 bit Output Streams</td> </tr> <tr> <td>1Fh = 32B</td> <td>8, 16, 20, 24, or 32 bit Output Streams</td> </tr> <tr> <td>3Fh = 64B</td> <td>8, 16, 20, 24, or 32 bit Output Streams</td> </tr> <tr> <td>7Fh = 128B</td> <td>8, 16, 20, 24, or 32 bit Output Streams</td> </tr> <tr> <td>BFh = 192B</td> <td>8, 16, or 32 bit Output Streams</td> </tr> <tr> <td>FFh = 256B</td> <td>20, 24 bit Output Streams</td> </tr> </tbody> </table> <p>NOTES:</p> <ol style="list-style-type: none"> All other values not listed are not supported. When the output stream is programmed to an unsupported size, the hardware sets itself to the default value (BFh). Software must read the bit field to test if the value is supported after setting the bit field. <p><i>Input Stream RO value:</i></p> <table border="1"> <thead> <tr> <th>Value</th> <th>Input Streams</th> </tr> </thead> <tbody> <tr> <td>77h = 120B</td> <td>8, 16, 32 bit Input Streams</td> </tr> <tr> <td>9Fh = 160B</td> <td>20, 24 bit Input Streams</td> </tr> </tbody> </table> <p>NOTE: The default value is different for input and output streams, and reflects the default state of the BITS fields (in Stream Descriptor Format registers) for the corresponding stream.</p>	Value	Output Streams	0Fh = 16B	8, 16, 20, 24, or 32 bit Output Streams	1Fh = 32B	8, 16, 20, 24, or 32 bit Output Streams	3Fh = 64B	8, 16, 20, 24, or 32 bit Output Streams	7Fh = 128B	8, 16, 20, 24, or 32 bit Output Streams	BFh = 192B	8, 16, or 32 bit Output Streams	FFh = 256B	20, 24 bit Output Streams	Value	Input Streams	77h = 120B	8, 16, 32 bit Input Streams	9Fh = 160B	20, 24 bit Input Streams
Value	Output Streams																				
0Fh = 16B	8, 16, 20, 24, or 32 bit Output Streams																				
1Fh = 32B	8, 16, 20, 24, or 32 bit Output Streams																				
3Fh = 64B	8, 16, 20, 24, or 32 bit Output Streams																				
7Fh = 128B	8, 16, 20, 24, or 32 bit Output Streams																				
BFh = 192B	8, 16, or 32 bit Output Streams																				
FFh = 256B	20, 24 bit Output Streams																				
Value	Input Streams																				
77h = 120B	8, 16, 32 bit Input Streams																				
9Fh = 160B	20, 24 bit Input Streams																				



18.2.40 SDFMT—Stream Descriptor Format Register (Intel® High Definition Audio Controller—D27:F0)

Memory Address: Input Stream[0]: HDBAR + 92h Attribute: R/W
 Input Stream[1]: HDBAR + B2h
 Input Stream[2]: HDBAR + D2h
 Input Stream[3]: HDBAR + F2h
 Output Stream[0]: HDBAR + 112h
 Output Stream[1]: HDBAR + 132h
 Output Stream[2]: HDBAR + 152h
 Output Stream[3]: HDBAR + 172h

Default Value: 0000h Size: 16 bits

Bit	Description
15	Reserved.
14	Sample Base Rate — R/W 0 = 48 kHz 1 = 44.1 kHz
13:11	Sample Base Rate Multiple — R/W 000 = 48 kHz, 44.1 kHz or less 001 = x2 (96 kHz, 88.2 kHz, 32 kHz) 010 = x3 (144 kHz) 011 = x4 (192 kHz, 176.4 kHz) Others = Reserved.
10:8	Sample Base Rate Divisor — R/W. 000 = Divide by 1 (48 kHz, 44.1 kHz) 001 = Divide by 2 (24 kHz, 22.05 kHz) 010 = Divide by 3 (16 kHz, 32 kHz) 011 = Divide by 4 (11.025 kHz) 100 = Divide by 5 (9.6 kHz) 101 = Divide by 6 (8 kHz) 110 = Divide by 7 111 = Divide by 8 (6 kHz)
7	Reserved.
6:4	Bits per Sample (BITS) — R/W. 000 = 8 bits. The data will be packed in memory in 8-bit containers on 16-bit boundaries 001 = 16 bits. The data will be packed in memory in 16-bit containers on 16-bit boundaries 010 = 20 bits. The data will be packed in memory in 32-bit containers on 32-bit boundaries 011 = 24 bits. The data will be packed in memory in 32-bit containers on 32-bit boundaries 100 = 32 bits. The data will be packed in memory in 32-bit containers on 32-bit boundaries Others = Reserved.
3:0	Number of Channels (CHAN) — R/W. Indicates number of channels in each frame of the stream. 0000 =1 0001 =2 1111 =16

18.2.41 SBDPDL—Stream Descriptor Buffer Descriptor List Pointer Lower Base Address Register (Intel® High Definition Audio Controller—D27:F0)

Memory Address: Input Stream[0]: HDBAR + 98h Attribute: R/W,RO
 Input Stream[1]: HDBAR + B8h
 Input Stream[2]: HDBAR + D8h
 Input Stream[3]: HDBAR + F8h
 Output Stream[0]: HDBAR + 118h
 Output Stream[1]: HDBAR + 138h
 Output Stream[2]: HDBAR + 158h
 Output Stream[3]: HDBAR + 178h

Default Value: 00000000h Size: 32 bits

Bit	Description
31:7	Buffer Descriptor List Pointer Lower Base Address — R/W. Lower address of the Buffer Descriptor List. This value should only be modified when the RUN bit is 0, or DMA transfer may be corrupted.
6:0	Hardwired to 0 forcing alignment on 128-B boundaries.

18.2.42 SBDPU—Stream Descriptor Buffer Descriptor List Pointer Upper Base Address Register (Intel® High Definition Audio Controller—D27:F0)

Memory Address: Input Stream[0]: HDBAR + 9Ch Attribute: R/W
 Input Stream[1]: HDBAR + BCh
 Input Stream[2]: HDBAR + DCh
 Input Stream[3]: HDBAR + FCh
 Output Stream[0]: HDBAR + 11Ch
 Output Stream[1]: HDBAR + 13Ch
 Output Stream[2]: HDBAR + 15Ch
 Output Stream[3]: HDBAR + 17Ch

Default Value: 00000000h Size: 32 bits

Bit	Description
31:0	Buffer Descriptor List Pointer Upper Base Address — R/W. Upper 32-bit address of the Buffer Descriptor List. This value should only be modified when the RUN bit is 0, or DMA transfer may be corrupted.

§

19 PCI Express* Configuration Registers

19.1 PCI Express* Configuration Registers (PCI Express—D28:F0/F1/F2/F3)

Note: Register address locations that are not shown in Table 19-1 and should be treated as Reserved.

Table 19-1. PCI Express* Configuration Registers Address Map (PCI Express—D28:F0/F1/F2/F3) (Sheet 1 of 3)

Offset	Mnemonic	Register Name	Function 0 Default	Function 1 Default	Function 2 Default	Function 3 Default	Type
00–01h	VID	Vendor Identification	8086h	8086h	8086h	8086h	RO
02–03h	DID	Device Identification	2660h	2662h	2664h	2666h	RO
04–05h	PCICMD	PCI Command	0000h	0000h	0000h	0000h	R/W, RO
06–07h	PCISTS	PCI Status	0010h	0010h	0010h	0010h	R/WC, RO
08h	RID	Revision Identification	See register description.	See register description.	See register description.	See register description.	RO
09h	PI	Programming Interface	00h	00h	00h	00h	RO
0Ah	SCC	Sub Class Code	04h	04h	04h	04h	RO
0Bh	BCC	Base Class Code	06h	06h	06h	06h	RO
0Ch	CLS	Cache Line Size	00h	00h	00h	00h	R/W
0Dh	PLT	Primary Latency Timer	00h	00h	00h	00h	RO
0Eh	HEADTYP	Header Type	81h	81h	81h	81h	RO
18–1Ah	BNUM	Bus Number	000000h	000000h	000000h	000000h	R/W
1C–1Dh	IOBL	I/O Base and Limit	0000h	0000h	0000h	0000h	R/W, RO
1E–1Fh	SSTS	Secondary Status Register	0000h	0000h	0000h	0000h	R/WC
20–23h	MBL	Memory Base and Limit	00000000h	00000000h	00000000h	00000000h	R/W
24–27h	PMBL	Prefetchable Memory Base and Limit	00010001h	00010001h	00010001h	00010001h	R/W, RO
28–2Bh	PMBU32	Prefetchable Memory Base Upper 32 Bits	00000000h	00000000h	00000000h	00000000h	R/W
2C–2Fh	PMLU32	Prefetchable Memory Limit Upper 32 Bits	00000000h	00000000h	00000000h	00000000h	R/W
34h	CAPP	Capabilities List Pointer	40h	40h	40h	40h	RO
3C–3Dh	INTR	Interrupt Information	See bit description	See bit description	See bit description	See bit description	R/W, RO
3E–3Fh	BCTRL	Bridge Control Register	0000h	0000h	0000h	0000h	R/W

**Table 19-1. PCI Express* Configuration Registers Address Map
(PCI Express—D28:F0/F1/F2/F3) (Sheet 2 of 3)**

Offset	Mnemonic	Register Name	Function 0 Default	Function 1 Default	Function 2 Default	Function 3 Default	Type
40–41h	CLIST	Capabilities List	8010	8010	8010	8010	RO
42–43h	XCAP	PCI Express* Capabilities	0041	0041	0041	0041	R/WO, RO
44–47h	DCAP	Device Capabilities	0000FE0h	0000FE0h	0000FE0h	0000FE0h	RO
48–49h	DCTL	Device Control	0000h	0000h	0000h	0000h	R/W, RO
4A–4Bh	DSTS	Device Status	0010h	0010h	0010h	0010h	R/WC, RO
4C–4Fh	LCAP	Link Capabilities	See bit description	See bit description	See bit description	See bit description	R/W, RO, R/WO
50–51h	LCTL	Link Control	0000h	0000h	0000h	0000h	R/W, R/W (special), RO
52–53h	LSTS	Link Status	See bit description	See bit description	See bit description	See bit description	RO
54–57h	SLCAP	Slot Capabilities Register	00000060h	00000060h	00000060h	00000060h	R/WO, RO
58–59h	SLCTL	Slot Control	0000h	0000h	0000h	0000h	R/W, RO
5A–5Bh	SLSTS	Slot Status	0000h	0000h	0000h	0000h	R/WC, RO
5C–5Dh	RCTL	Root Control	0000h	0000h	0000h	0000h	R/W
60–63h	RSTS	Root Status	00000000h	00000000h	00000000h	00000000h	R/WC, RO
80–81h	MID	Message Signaled Interrupt Identifiers	9005h	9005h	9005h	9005h	RO
82–83h	MC	Message Signaled Interrupt Message Control	0000h	0000h	0000h	0000h	R/W, RO
84–87h	MA	Message Signaled Interrupt Message Address	00000000h	00000000h	00000000h	00000000h	R/W
88–89h	MD	Message Signaled Interrupt Message Data	0000h	0000h	0000h	0000h	R/W
90–91h	SVCAP	Subsystem Vendor Capability	A00Dh	A00Dh	A00Dh	A00Dh	RO
94–97h	SVID	Subsystem Vendor Identification	00000000h	00000000h	00000000h	00000000h	R/WO
A0–A1h	PMCAP	Power Management Capability	0001h	0001h	0001h	0001h	RO
A2–A3h	PMC	PCI Power Management Capability	C802h	C802h	C802h	C802h	RO
A4–A7h	PMCS	PCI Power Management Control and Status	00000000h	00000000h	00000000h	00000000h	R/W, RO
D8–DBh	MPC	Miscellaneous Port Configuration	00110000h	00110000h	00110000h	00110000h	R/W
DC–DFh	SMSCS	SMI/SCI Status Register	00000000h	00000000h	00000000h	00000000h	R/WC
100–103h	VCH	Virtual Channel Capability Header	18010002h	18010002h	18010002h	18010002h	RO
108–10Bh	VCAP2	Virtual Channel Capability 2	00000001h	00000001h	00000001h	00000001h	RO

**Table 19-1. PCI Express* Configuration Registers Address Map
(PCI Express—D28:F0/F1/F2/F3) (Sheet 3 of 3)**

Offset	Mnemonic	Register Name	Function 0 Default	Function 1 Default	Function 2 Default	Function 3 Default	Type
10C–10Dh	PVC	Port Virtual Channel Control	0000h	0000h	0000h	0000h	R/W
10E–10Fh	PVS	Port Virtual Channel Status	0000h	0000h	0000h	0000h	RO
110–113h	V0CAP	Virtual Channel 0 Resource Capability	00000001h	00000001h	00000001h	00000001h	RO
114–117h	V0CTL	Virtual Channel 0 Resource Control	800000FFh	800000FFh	800000FFh	800000FFh	R/W, RO
11A–11Bh	V0STS	Virtual Channel 0 Resource Status	0000h	0000h	0000h	0000h	RO
144–147h	UES	Uncorrectable Error Status	See bit description	See bit description	See bit description	See bit description	R/WC, RO
148–14Bh	UEM	Uncorrectable Error Mask	00000000h	00000000h	00000000h	00000000h	R/WO, RO
14C–14Fh	UEV	Uncorrectable Error Severity	00060011h	00060011h	00060011h	00060011h	RO
150–153h	CES	Correctable Error Status	00000000h	00000000h	00000000h	00000000h	R/WC
154–157h	CEM	Correctable Error Mask	00000000h	00000000h	00000000h	00000000h	R/WO
158–15Bh	AECC	Advanced Error Capabilities and Control	00000000h	00000000h	00000000h	00000000h	RO
170–173h	RES	Root Error Status	00000000h	00000000h	00000000h	00000000h	R/WC, RO
180–183h	RCTCL	Root Complex Topology Capability List	00010005h	00010005h	00010005h	00010005h	RO
184–187h	ESD	Element Self Description	See bit description	See bit description	See bit description	See bit description	RO
190–193h	ULD	Upstream Link Description	00000001h	00000001h	00000001h	00000001h	RO
198–19Fh	ULBA	Upstream Link Base Address	See bit description	See bit description	See bit description	See bit description	RO
314h	PCIECR1	PCI Express Configuration Register 1	00C4B0DBh	00C4B0DBh	00C4B0DBh	00C4B0DBh	R/W
318h	PCIECR2	PCI Express Configuration Register 2	0A200000h	0A200000h	0A200000h	0A200000h	R/W



19.1.1 VID—Vendor Identification Register (PCI Express—D28:F0/F1/F2/F3)

Address Offset: 00–01h Attribute: RO
 Default Value: 8086h Size: 16 bits

Bit	Description
15:0	Vendor ID — RO. This is a 16-bit value assigned to Intel

19.1.2 DID—Device Identification Register (PCI Express—D28:F0/F1/F2/F3)

Address Offset: 02–03h Attribute: RO
 Default Value: Port 1= 2660h
 Port 2= 2662h
 Port 3= 2664h
 Port 4= 2666h
 Size: 16 bits

Bit	Description
15:0	Device ID — RO.

19.1.3 PCICMD—PCI Command Register (PCI Express—D28:F0/F1/F2/F3)

Address Offset: 04–05h
Default Value: 0000h

Attribute: R/W, RO
Size: 16 bits

Bit	Description
15:11	Reserved
10	<p>Interrupt Disable — R/W. This disables pin-based INTx# interrupts on enabled Hot-Plug and power management events. This bit has no effect on MSI operation.</p> <p>0 = Internal INTx# messages are generated if there is an interrupt for Hot-Plug or power management and MSI is not enabled. 1 = Internal INTx# messages will not be generated.</p> <p>This bit does not affect interrupt forwarding from devices connected to the root port. Assert_INTx and de-assert_INTx messages will still be forwarded to the internal interrupt controllers if this bit is set.</p>
9	Fast Back to Back Enable (FBE) — Reserved per the <i>PCI Express* Base Specification</i> .
8	<p>SERR# Enable (SEE) — R/W.</p> <p>0 = Disable. 1 = Enables the root port to generate an SERR# message when PSTS.SSE is set.</p>
7	Wait Cycle Control (WCC) — Reserved per the <i>PCI Express Base Specification</i> .
6	<p>Parity Error Response (PER) — R/W.</p> <p>0 = Disable. 1 = Indicates that the device is capable of reporting parity errors as a master on the backbone.</p>
5	VGA Palette Snoop (VPS) — Reserved per the <i>PCI Express* Base Specification</i> .
4	Postable Memory Write Enable (PMWE) — Reserved per the <i>PCI Express* Base Specification</i> .
3	Special Cycle Enable (SCE) — Reserved per the <i>PCI Express* Base Specification</i> .
2	<p>Bus Master Enable (BME) — R/W.</p> <p>0 = Disable. All cycles from the device are master aborted 1 = Enable. Allows the root port to forward cycles onto the backbone from a PCI Express* device.</p>
1	<p>Memory Space Enable (MSE) — R/W.</p> <p>0 = Disable. Memory cycles within the range specified by the memory base and limit registers are master aborted on the backbone. 1 = Enable. Allows memory cycles within the range specified by the memory base and limit registers can be forwarded to the PCI Express device.</p>
0	<p>I/O Space Enable (IOSE) — R/W. This bit controls access to the I/O space registers.</p> <p>0 = Disable. I/O cycles within the range specified by the I/O base and limit registers are master aborted on the backbone. 1 = Enable. Allows I/O cycles within the range specified by the I/O base and limit registers can be forwarded to the PCI Express device.</p>

19.1.4 PCISTS—PCI Status Register (PCI Express—D28:F0/F1/F2/F3)

Address Offset: 06–07h
Default Value: 0010h

Attribute: R/WC, RO
Size: 16 bits

Bit	Description
15	Detected Parity Error (DPE) — R/WC. 0 = No parity error detected. 1 = Set when the root port receives a command or data from the backbone with a parity error. This is set even if PCIMD.PER (D28:F0/F1/F2/F3:04, bit 6) is not set.
14	Signaled System Error (SSE) — R/WC. 0 = No system error signaled. 1 = Set when the root port signals a system error to the internal SERR# logic.
13	Received Master Abort (RMA) — R/WC. 0 = Root port has not received a completion with unsupported request status from the backbone. 1 = Set when the root port receives a completion with unsupported request status from the backbone.
12	Received Target Abort (RTA) — R/WC. 0 = Root port has not received a completion with completer abort from the backbone. 1 = Set when the root port receives a completion with completer abort from the backbone.
11	Signaled Target Abort (STA) — R/WC. 0 = No target abort received. 1 = Set whenever the root port forwards a target abort received from the downstream device onto the backbone.
10:9	DEVSEL# Timing Status (DEV_STS) — Reserved per the <i>PCI Express* Base Specification</i> .
8	Master Data Parity Error Detected (DPED) — R/WC. 0 = No data parity error received. 1 = Set when the root port receives a completion with a data parity error on the backbone and PCIMD.PER (D28:F0/F1/F2/F3:04, bit 6) is set.
7	Fast Back to Back Capable (FB2BC) — Reserved per the <i>PCI Express* Base Specification</i> .
6	Reserved
5	66 MHz Capable — Reserved per the <i>PCI Express* Base Specification</i> .
4	Capabilities List — RO. Hardwired to 1. Indicates the presence of a capabilities list.
3	Interrupt Status — RO. Indicates status of Hot-Plug and power management interrupts on the root port that result in INTx# message generation. 0 = Interrupt is de-asserted. 1 = Interrupt is asserted. This bit is not set if MSI is enabled. If MSI is not enabled, this bit is set regardless of the state of PCICMD.Interrupt Disable bit (D28:F0/F1/F2/F3:04h:bit 10).
2:0	Reserved

19.1.9 CLS—Cache Line Size Register (PCI Express—D28:F0/F1/F2/F3)

Address Offset: 0Ch Attribute: R/W
Default Value: 00h Size: 8 bits

Bit	Description
7:0	Base Class Code (BCC) — R/W. This is read/write but contains no functionality, per the <i>PCI* Express Base Specification</i> .

19.1.10 PLT—Primary Latency Timer Register (PCI Express—D28:F0/F1/F2/F3)

Address Offset: 0Dh Attribute: RO
Default Value: 00h Size: 8 bits

Bit	Description
7:3	Latency Count. Reserved per the <i>PCI Express* Base Specification</i> .
2:0	Reserved

19.1.11 HEADTYP—Header Type Register (PCI Express—D28:F0/F1/F2/F3)

Address Offset: 0Eh Attribute: RO
Default Value: 81h Size: 8 bits

Bit	Description
7	Multi-Function Device — RO. 0 = Single-function device. 1 = Multi-function device.
6:0	Configuration Layout. Hardwired to 01h, which indicates a PCI-to-PCI bridge.

19.1.12 BNUM—Bus Number Register (PCI Express—D28:F0/F1/F2/F3)

Address Offset: 18–1Ah Attribute: R/W
Default Value: 000000h Size: 24 bits

Bit	Description
23:16	Subordinate Bus Number (SBBN) — R/W. Indicates the highest PCI bus number below the bridge.
15:8	Secondary Bus Number (SCBN) — R/W. Indicates the bus number the port.
7:0	Primary Bus Number (PBN) — R/W. Indicates the bus number of the backbone.

19.1.13 IOBL—I/O Base and Limit Register (PCI Express—D28:F0/F1/F2/F3)

Address Offset: 1C–1Dh
Default Value: 0000h

Attribute: R/W, RO
Size: 16 bits

Bit	Description
15:12	I/O Limit Address (IOLA) — R/W. I/O Base bits corresponding to address lines 15:12 for 4-KB alignment. Bits 11:0 are assumed to be padded to FFFh.
11:8	I/O Limit Address Capability (IOLC) — R/O. Indicates that the bridge does not support 32-bit I/O addressing.
7:4	I/O Base Address (IOBA) — R/W. I/O Base bits corresponding to address lines 15:12 for 4-KB alignment. Bits 11:0 are assumed to be padded to 000h.
3:0	I/O Base Address Capability (IOBC) — R/O. Indicates that the bridge does not support 32-bit I/O addressing.

19.1.14 SSTS—Secondary Status Register (PCI Express—D28:F0/F1/F2/F3)

Address Offset: 1E–1Fh Attribute: R/WC
 Default Value: 0000h Size: 16 bits

Bit	Description
15	Detected Parity Error (DPE) — R/WC. 0 = No error. 1 = The port received a poisoned TLP.
14	Received System Error (RSE) — R/WC. 0 = No error. 1 = The port received an ERR_FATAL or ERR_NONFATAL message from the device.
13	Received Master Abort (RMA) — R/WC. 0 = Unsupported Request not received. 1 = The port received a completion with “Unsupported Request” status from the device.
12	Received Target Abort (RTA) — R/WC. 0 = Completion Abort not received. 1 = The port received a completion with “Completion Abort” status from the device.
11	Signaled Target Abort (STA) — R/WC. 0 = Completion Abort not sent. 1 = The port generated a completion with “Completion Abort” status to the device.
10:9	Secondary DEVSEL# Timing Status (SDTS): Reserved per <i>PCI Express* Base Specification</i> .
8	Data Parity Error Detected (DPD) — R/WC. 0 = Conditions below did not occur. 1 = Set when the BCTRL.PERE (D28:F0/F1/F2/F3:3E: bit 0) is set, and either of the following two conditions occurs: <ul style="list-style-type: none"> • Port receives completion marked poisoned. • Port poisons a write request to the secondary side.
7	Secondary Fast Back to Back Capable (SFBC): Reserved per <i>PCI Express* Base Specification</i> .
6	Reserved
5	Secondary 66 MHz Capable (SC66): Reserved per <i>PCI Express* Base Specification</i> .
4:0	Reserved

19.1.17 PMBU32—Prefetchable Memory Base Upper 32 Bits Register (PCI Express—D28:F0/F1/F2/F3)

Address Offset: 28–2Bh Attribute: R/W
 Default Value: 00000000h Size: 32 bits

Bit	Description
31:0	Prefetchable Memory Base Upper Portion (PMBU) — R/W. Upper 32-bits of the prefetchable address base.

19.1.18 PMLU32—Prefetchable Memory Limit Upper 32 Bits Register (PCI Express—D28:F0/F1/F2/F3)

Address Offset: 2C–2Fh Attribute: R/W
 Default Value: 00000000h Size: 32 bits

Bit	Description
31:0	Prefetchable Memory Limit Upper Portion (PMLU) — R/W. Upper 32-bits of the prefetchable address limit.

19.1.19 CAPP—Capabilities List Pointer Register (PCI Express—D28:F0/F1/F2/F3)

Address Offset: 34h Attribute: R0
 Default Value: 40h Size: 8 bits

Bit	Description
7:0	Capabilities Pointer (PTR) — RO. This field indicates that the pointer for the first entry in the capabilities list is at 40h in configuration space.

19.1.20 INTR—Interrupt Information Register (PCI Express—D28:F0/F1/F2/F3)

Address Offset: 3C–3Dh Attribute: R/W, RO
 Default Value: See bit description Size: 16 bits

Bit	Description										
15:8	<p>Interrupt Pin (IPIN) — RO. This field indicates the interrupt pin driven by the root port. At reset, this register takes on the following values, which reflect the reset state of the D28IP register in chipset configuration space:</p> <table border="1"> <thead> <tr> <th>Port</th> <th>Reset Value</th> </tr> </thead> <tbody> <tr> <td>1</td> <td>D28IP.P1IP</td> </tr> <tr> <td>2</td> <td>D28IP.P2IP</td> </tr> <tr> <td>3</td> <td>D28IP.P3IP</td> </tr> <tr> <td>4</td> <td>D28IP.P4IP</td> </tr> </tbody> </table> <p>NOTE: The value that is programmed into D28IP is always reflected in this register.</p>	Port	Reset Value	1	D28IP.P1IP	2	D28IP.P2IP	3	D28IP.P3IP	4	D28IP.P4IP
Port	Reset Value										
1	D28IP.P1IP										
2	D28IP.P2IP										
3	D28IP.P3IP										
4	D28IP.P4IP										
7:0	Interrupt Line (ILINE) — R/W. Default = 00h. Software written value to indicate which interrupt line (vector) the interrupt is connected to. No hardware action is taken on this register.										



19.1.21 BCTRL—Bridge Control Register (PCI Express—D28:F0/F1/F2/F3)

Address Offset: 3E–3Fh Attribute: R/W
 Default Value: 0000h Size: 16 bits

Bit	Description
15:12	Reserved
11	Discard Timer SERR# Enable (DTSE): Reserved per <i>PCI Express* Base Specification, Revision 1.0a</i>
10	Discard Timer Status (DTS): Reserved per <i>PCI Express* Base Specification, Revision 1.0a</i> .
9	Secondary Discard Timer (SDT): Reserved per <i>PCI Express* Base Specification, Revision 1.0a</i> .
8	Primary Discard Timer (PDT): Reserved per <i>PCI Express* Base Specification, Revision 1.0a</i> .
7	Fast Back to Back Enable (FBE): Reserved per <i>PCI Express* Base Specification, Revision 1.0a</i> .
6	Secondary Bus Reset (SBR) — R/W. Triggers a hot reset on the PCI Express* port.
5	Master Abort Mode (MAM): Reserved per Express specification.
4	VGA 16-Bit Decode (V16) — R/W. 0 = VGA range is enabled. 1 = The I/O aliases of the VGA range (see BCTRL:VE definition below), are not enabled, and only the base I/O ranges can be decoded
3	VGA Enable (VE) — R/W. 0 = The ranges below will not be claimed off the backbone by the root port. 1 = The following ranges will be claimed off the backbone by the root port: <ul style="list-style-type: none"> • Memory ranges A0000h–BFFFFh • I/O ranges 3B0h – 3BBh and 3C0h – 3DFh, and all aliases of bits 15:10 in any combination of 1s
2	ISA Enable (IE) — R/W. This bit only applies to I/O addresses that are enabled by the I/O Base and I/O Limit registers and are in the first 64 KB of PCI I/O space. 0 = The root port will not block any forwarding from the backbone as described below. 1 = The root port will block any forwarding from the backbone to the device of I/O transactions addressing the last 768 bytes in each 1-KB block (offsets 100h to 3FFh).
1	SERR# Enable (SE) — R/W. 0 = The messages described below are not forwarded to the backbone. 1 = ERR_COR, ERR_NONFATAL, and ERR_FATAL messages received are forwarded to the backbone.
0	Parity Error Response Enable (PERE) — R/W. When set, 0 = Poisoned write TLPs and completions indicating poisoned TLPs will not set the SSTS.DPD (D28:F0/F1/F2/F3:1E, bit 8). 1 = Poisoned write TLPs and completions indicating poisoned TLPs will set the SSTS.DPD (D28:F0/F1/F2/F3:1E, bit 8).

19.1.22 CLIST—Capabilities List Register (PCI Express—D28:F0/F1/F2/F3)

Address Offset: 40–41h Attribute: RO
 Default Value: 8010h Size: 16 bits

Bit	Description
15:8	Next Capability (NEXT) — RO. Value of 80h indicates the location of the next pointer.
7:0	Capability ID (CID) — RO. This field indicates this is a PCI Express* capability.

19.1.23 XCAP—PCI Express* Capabilities Register (PCI Express—D28:F0/F1/F2/F3)

Address Offset: 42–43h Attribute: R/WO, RO
 Default Value: 0041h Size: 16 bits

Bit	Description
15:14	Reserved
13:9	Interrupt Message Number (IMN) — RO. The Intel® ICH6 does not have multiple MSI interrupt numbers.
8	Slot Implemented (SI) — R/WO. This field indicates whether the root port is connected to a slot. Slot support is platform specific. BIOS programs this field, and it is maintained until a platform reset.
7:4	Device / Port Type (DT) — RO. This field indicates this is a PCI Express* root port.
3:0	Capability Version (CV) — RO. This field indicates PCI Express 1.0.

19.1.24 DCAP—Device Capabilities Register (PCI Express—D28:F0/F1/F2/F3)

Address Offset: 44–47h Attribute: RO
 Default Value: 00000FE0h Size: 32 bits

Bit	Description
31:28	Reserved
27:26	Captured Slot Power Limit Scale (CSPS) — RO. Not supported.
25:18	Captured Slot Power Limit Value (CSPV) — RO. Not supported.
17:15	Reserved
14	Power Indicator Present (PIP) — RO. This bit indicates no power indicator is present on the root port.
13	Attention Indicator Present (AIP) — RO. This bit indicates no attention indicator is present on the root port.
12	Attention Button Present (ABP) — RO. This bit indicates no attention button is present on the root port.
11:9	Endpoint L1 Acceptable Latency (E1AL) — RO. This field indicates more than 4 μ s. This field essentially has no meaning for root ports since root ports are not endpoints.
8:6	Endpoint L0 Acceptable Latency (E0AL) — RO. This field indicates more than 64 μ s. This field essentially has no meaning for root ports since root ports are not endpoints.
5	Extended Tag Field Supported (ETFS) — RO. This bit indicates that 8-bit tag fields are supported.
4:3	Phantom Functions Supported (PFS) — RO. No phantom functions supported.
2:0	Max Payload Size Supported (MPS) — RO. This field indicates the maximum payload size supported is 128B.

19.1.25 DCTL—Device Control Register (PCI Express—D28:F0/F1/F2/F3)

Address Offset: 48–49h Attribute: R/W, RO
 Default Value: 0000h Size: 16 bits

Bit	Description
15	Reserved
14:12	Max Read Request Size (MRRS) — RO. Hardwired to 0.
11	Enable No Snoop (ENS) — RO. Not supported. The root port will never issue non-snoop requests.
10	Aux Power PM Enable (APME) — R/W. The OS will set this bit to 1 if the device connected has detected aux power. It has no effect on the root port otherwise.
9	Phantom Functions Enable (PFE) — RO. Not supported.
8	Extended Tag Field Enable (ETFE) — RO. Not supported.
7:5	Max Payload Size (MPS) — R/W. The root port only supports 128-B payloads, regardless of the programming of this field.
4	Enable Relaxed Ordering (ERO) — RO. Not supported.
3	Unsupported Request Reporting Enable (URE) — R/W. 0 = The root port will ignore unsupported request errors. 1 = The root port will generate errors when detecting an unsupported request.
2	Fatal Error Reporting Enable (FEE) — R/W. 0 = The root port will ignore fatal errors. 1 = The root port will generate errors when detecting a fatal error.
1	Non-Fatal Error Reporting Enable (NFE) — R/W. 0 = The root port will ignore non-fatal errors. 1 = The root port will generate errors when detecting a non-fatal error.
0	Correctable Error Reporting Enable (CEE) — R/W. 0 = The root port will ignore correctable errors. 1 = The root port will generate errors when detecting a correctable error.

19.1.26 DSTS—Device Status Register (PCI Express—D28:F0/F1/F2/F3)

Address Offset: 4A–4Bh
Default Value: 0010h

Attribute: R/WC, RO
Size: 16 bits

Bit	Description
15:6	Reserved
5	Transactions Pending (TDP) — RO. This bit has no meaning for the root port since only one transaction may be pending to the Intel® ICH6, so a read of this bit cannot occur until it has already returned to 0.
4	AUX Power Detected (APD) — RO. The root port contains AUX power for wakeup.
3	Unsupported Request Detected (URD) — R/WC. Indicates an unsupported request was detected.
2	Fatal Error Detected (FED) — R/WC. This bit indicates a fatal error was detected. 0 = Fatal has not occurred. 1 = A fatal error occurred from a data link protocol error, link training error, buffer overflow, or malformed TLP.
1	Non-Fatal Error Detected (NFED) — R/WC. This bit indicates a non-fatal error was detected. 0 = Non-fatal has not occurred. 1 = A non-fatal error occurred from a poisoned TLP, unexpected completions, unsupported requests, completer abort, or completer timeout.
0	Correctable Error Detected (CED) — R/WC. This bit indicates a correctable error was detected. 0 = Correctable has not occurred. 1 = The port received an internal correctable error from receiver errors / framing errors, TLP CRC error, DLLP CRC error, replay num rollover, replay timeout.

19.1.27 LCAP—Link Capabilities Register (PCI Express—D28:F0/F1/F2/F3)

Address Offset: 4C–4Fh Attribute: R/W, RO
 Default Value: See bit description Size: 32 bits

Bit	Description																	
31:24	<p>Port Number (PN) — RO. This field indicates the port number for the root port. This value is different for each implemented port:</p> <table border="1"> <thead> <tr> <th>Function</th> <th>Port #</th> <th>Value of PN Field</th> </tr> </thead> <tbody> <tr> <td>D28:F0</td> <td>1</td> <td>01h</td> </tr> <tr> <td>D28:F1</td> <td>2</td> <td>02h</td> </tr> <tr> <td>D28:F2</td> <td>3</td> <td>03h</td> </tr> <tr> <td>D28:F3</td> <td>4</td> <td>04h</td> </tr> </tbody> </table>	Function	Port #	Value of PN Field	D28:F0	1	01h	D28:F1	2	02h	D28:F2	3	03h	D28:F3	4	04h		
Function	Port #	Value of PN Field																
D28:F0	1	01h																
D28:F1	2	02h																
D28:F2	3	03h																
D28:F3	4	04h																
23:18	Reserved																	
17:15	L1 Exit Latency (EL1) — RO. Set to 010b to indicate an exit latency of 2 μ s to 4 μ s.																	
14:12	<p>L0s Exit Latency (EL0) — RO. This field indicates as exit latency based upon common-clock configuration.</p> <table border="1"> <thead> <tr> <th>LCLT.CCC</th> <th>Value of EL0 (these bits)</th> </tr> </thead> <tbody> <tr> <td>0</td> <td>MPC.UCEL (D28:F0/F1/F2/F3:D8h:bits20:18)</td> </tr> <tr> <td>1</td> <td>MPC.CCEL (D28:F0/F1/F2/F3:D8h:bits17:15)</td> </tr> </tbody> </table> <p>NOTE:LCLT.CCC is at D28:F0/F1/F2/F3:50h:bit 6</p>	LCLT.CCC	Value of EL0 (these bits)	0	MPC.UCEL (D28:F0/F1/F2/F3:D8h:bits20:18)	1	MPC.CCEL (D28:F0/F1/F2/F3:D8h:bits17:15)											
LCLT.CCC	Value of EL0 (these bits)																	
0	MPC.UCEL (D28:F0/F1/F2/F3:D8h:bits20:18)																	
1	MPC.CCEL (D28:F0/F1/F2/F3:D8h:bits17:15)																	
11:10	<p>Active State Link PM Support (APMS) — R/WO. This field indicates what level of active state link power management is supported on the root port. Value fixed at 11b.</p> <table border="1"> <thead> <tr> <th>Bits</th> <th>Definition</th> </tr> </thead> <tbody> <tr> <td>00b</td> <td>Neither L0s nor L1 are supported</td> </tr> <tr> <td>01b</td> <td>L0s Entry Supported</td> </tr> <tr> <td>10b</td> <td>L1 Entry Supported</td> </tr> <tr> <td>11b</td> <td>Both L0s and L1 Entry Supported</td> </tr> </tbody> </table>	Bits	Definition	00b	Neither L0s nor L1 are supported	01b	L0s Entry Supported	10b	L1 Entry Supported	11b	Both L0s and L1 Entry Supported							
Bits	Definition																	
00b	Neither L0s nor L1 are supported																	
01b	L0s Entry Supported																	
10b	L1 Entry Supported																	
11b	Both L0s and L1 Entry Supported																	
9:4	<p>Maximum Link Width (MLW) — RO. For the root ports, several values can be taken, based upon the value of the chipset configuration register field RPC.PC (Chipset Configuration Registers:Offset 0224h:bits1:0):</p> <table border="1"> <thead> <tr> <th rowspan="2">Port #</th> <th colspan="2">Value of MLW Field</th> </tr> <tr> <th>RPC.PC=00b</th> <th>RPC.PC=11b</th> </tr> </thead> <tbody> <tr> <td>1</td> <td>01h</td> <td>04h</td> </tr> <tr> <td>2</td> <td>01h</td> <td>01h</td> </tr> <tr> <td>3</td> <td>01h</td> <td>01h</td> </tr> <tr> <td>4</td> <td>01h</td> <td>01h</td> </tr> </tbody> </table>	Port #	Value of MLW Field		RPC.PC=00b	RPC.PC=11b	1	01h	04h	2	01h	01h	3	01h	01h	4	01h	01h
Port #	Value of MLW Field																	
	RPC.PC=00b	RPC.PC=11b																
1	01h	04h																
2	01h	01h																
3	01h	01h																
4	01h	01h																
3:0	Maximum Link Speed (MLS) — RO. Set to 1h to indicate the link speed is 2.5 Gb/s.																	

19.1.28 LCTL—Link Control Register (PCI Express—D28:F0/F1/F2/F3)

Address Offset: 50–51h
Default Value: 0000h

Attribute: R/W, WO, RO
Size: 16 bits

Bit	Description										
15:8	Reserved										
7	<p>Extended Synch (ES) — R/W.</p> <p>0 = Extended synch disabled. 1 = Forces extended transmission of FTS ordered sets in FTS and extra TS2 at exit from L1 prior to entering L0.</p>										
6	<p>Common Clock Configuration (CCC) — R/W.</p> <p>0 = The ICH6 and device are not using a common reference clock. 1 = The ICH6 and device are operating with a distributed common reference clock.</p>										
5	<p>Retrain Link (RL) — WO.</p> <p>0 = This bit always returns 0 when read. 1 = The root port will train its downstream link.</p> <p>NOTE: Software uses LSTS.LT (D28:F0/F1/F2/F3:52, bit 11) to check the status of training.</p>										
4	<p>Link Disable (LD) — R/W.</p> <p>0 = Link enabled. 1 = The root port will disable the link.</p>										
3	<p>Read Completion Boundary Control (RCBC) — RO. This bit indicates the read completion boundary is 64 bytes.</p>										
2	Reserved										
1:0	<p>Active State Link PM Control (APMC) — R/W. This field indicates whether the root port should enter L0s or L1 or both.</p> <table border="1"> <thead> <tr> <th>Bits</th> <th>Definition</th> </tr> </thead> <tbody> <tr> <td>00b</td> <td>Disabled</td> </tr> <tr> <td>01b</td> <td>L0s Entry is Enabled</td> </tr> <tr> <td>10b</td> <td>L1 Entry is Enabled</td> </tr> <tr> <td>11b</td> <td>L0s and L1 Entry Enabled</td> </tr> </tbody> </table>	Bits	Definition	00b	Disabled	01b	L0s Entry is Enabled	10b	L1 Entry is Enabled	11b	L0s and L1 Entry Enabled
Bits	Definition										
00b	Disabled										
01b	L0s Entry is Enabled										
10b	L1 Entry is Enabled										
11b	L0s and L1 Entry Enabled										

19.1.29 LSTS—Link Status Register (PCI Express—D28:F0/F1/F2/F3)

Address Offset: 52–53h Attribute: RO
 Default Value: See bit description Size: 16 bits

Bit	Description										
15:13	Reserved										
12	Slot Clock Configuration (SCC) — RO. Set to 1b to indicate that the Intel® ICH6 uses the same reference clock as on the platform and does not generate its own clock.										
11	Link Training (LT) — RO. Default value is 0b. 0 = Link training completed. 1 = Link training is occurring.										
10	Link Training Error (LTE) — RO. Not supported. Set value is 0b.										
9:4	Negotiated Link Width (NLW) — RO. This field indicates the negotiated width of the given PCI Express* link. The contents of this NLW field is undefined if the link has not successfully trained. <table border="1"> <thead> <tr> <th>Port #</th> <th>Possible Values</th> </tr> </thead> <tbody> <tr> <td>1</td> <td>000001b, 000010b, 000100b</td> </tr> <tr> <td>2</td> <td>000001b</td> </tr> <tr> <td>3</td> <td>000001b</td> </tr> <tr> <td>4</td> <td>000001b</td> </tr> </tbody> </table> NOTE: 000001b = x1 link width, 000100b = x4 link width (Enterprise applications only)	Port #	Possible Values	1	000001b, 000010b, 000100b	2	000001b	3	000001b	4	000001b
Port #	Possible Values										
1	000001b, 000010b, 000100b										
2	000001b										
3	000001b										
4	000001b										
3:0	Link Speed (LS) — RO. This field indicates the negotiated Link speed of the given PCI Express* link. 01h = Link is 2.5 Gb/s.										



19.1.30 SLCAP—Slot Capabilities Register (PCI Express—D28:F0/F1/F2/F3)

Address Offset: 54–57h
Default Value: 00000060h

Attribute: R/WO, RO
Size: 32 bits

Bit	Description
31:19	Physical Slot Number (PSN) — R/WO. This is a value that is unique to the slot number. BIOS sets this field and it remains set until a platform reset.
18:17	Reserved
16:15	Slot Power Limit Scale (SLS) — R/WO. This field specifies the scale used for the slot power limit value. BIOS sets this field and it remains set until a platform reset.
14:7	Slot Power Limit Value (SLV) — R/WO. This field specifies the upper limit (in conjunction with SLS value), on the upper limit on power supplied by the slot. The two values together indicate the amount of power in watts allowed for the slot. BIOS sets this field and it remains set until a platform reset.
6	Hot Plug Capable (HPC) — RO. 1b = Indicates that Hot-Plug is supported.
5	Hot Plug Surprise (HPS) — RO. 1b = Indicates the device may be removed from the slot without prior notification.
4	Power Indicator Present (PIP) — RO. 0b = Indicates that a power indicator LED is not present for this slot.
3	Attention Indicator Present (AIP) — RO. 0b = Indicates that an attention indicator LED is not present for this slot.
2	MRL Sensor Present (MSP) — RO. 0b = Indicates that an MRL sensor is not present.
1	Power Controller Present (PCP) — RO. 0b = Indicates that a power controller is not implemented for this slot.
0	Attention Button Present (ABP) — RO. 0b = Indicates that an attention button is not implemented for this slot.

19.1.31 SLCTL—Slot Control Register (PCI Express—D28:F0/F1/F2/F3)

Address Offset: 58–59h
Default Value: 0000h

Attribute: R/W, RO
Size: 16 bits

Bit	Description										
15:11	Reserved										
10	Power Controller Control (PCC) — RO. This bit has no meaning for module based Hot-Plug.										
9:8	<p>Power Indicator Control (PIC) — R/W. When read, the current state of the power indicator is returned. When written, the appropriate POWER_INDICATOR_* messages are sent. Defined encodings are:</p> <table border="1"> <thead> <tr> <th>Bits</th> <th>Definition</th> </tr> </thead> <tbody> <tr> <td>00b</td> <td>Reserved</td> </tr> <tr> <td>01b</td> <td>On</td> </tr> <tr> <td>10b</td> <td>Blink</td> </tr> <tr> <td>11b</td> <td>Off</td> </tr> </tbody> </table>	Bits	Definition	00b	Reserved	01b	On	10b	Blink	11b	Off
Bits	Definition										
00b	Reserved										
01b	On										
10b	Blink										
11b	Off										
7:6	<p>Attention Indicator Control (AIC) — R/W. When read, the current state of the attention indicator is returned. When written, the appropriate ATTENTION_INDICATOR_* messages are sent. Defined encodings are:</p> <table border="1"> <thead> <tr> <th>Bits</th> <th>Definition</th> </tr> </thead> <tbody> <tr> <td>00b</td> <td>Reserved</td> </tr> <tr> <td>01b</td> <td>On</td> </tr> <tr> <td>10b</td> <td>Blink</td> </tr> <tr> <td>11b</td> <td>Off</td> </tr> </tbody> </table>	Bits	Definition	00b	Reserved	01b	On	10b	Blink	11b	Off
Bits	Definition										
00b	Reserved										
01b	On										
10b	Blink										
11b	Off										
5	<p>Hot Plug Interrupt Enable (HPE) — R/W.</p> <p>0 = Hot plug interrupts based on Hot-Plug events is disabled. 1 = Enables generation of a Hot-Plug interrupt on enabled Hot-Plug events.</p>										
4	<p>Command Completed Interrupt Enable (CCE) — R/W.</p> <p>0 = Hot plug interrupts based on command completions is disabled. 1 = Enables the generation of a Hot-Plug interrupt when a command is completed by the Hot-Plug controller.</p>										
3	<p>Presence Detect Changed Enable (PDE) — R/W.</p> <p>0 = Hot plug interrupts based on presence detect logic changes is disabled. 1 = Enables the generation of a Hot-Plug interrupt or wake message when the presence detect logic changes state.</p>										
2	<p>MRL Sensor Changed Enable (MSE) — R/W.</p> <p>MSE not supported.</p>										
1	<p>Power Fault Detected Enable (PFE) — R/W.</p> <p>PFE not supported.</p>										
0	<p>Attention Button Pressed Enable (ABE) — R/W. When set, enables the generation of a Hot-Plug interrupt when the attention button is pressed.</p> <p>0 = Hot plug interrupts based on the attention button being pressed is disabled. 1 = Enables the generation of a Hot-Plug interrupt when the attention button is pressed.</p>										

19.1.32 SLSTS—Slot Status Register (PCI Express—D28:F0/F1/F2/F3)

Address Offset: 5A–5Bh
Default Value: 0000h

Attribute: R/WC, RO
Size: 16 bits

Bit	Description
15:7	Reserved
6	Presence Detect State (PDS) — RO. If XCAP.SI (D28:F0/F1/F2/F3:42h:bit 8) is set (indicating that this root port spawns a slot), then this bit: 0 = Indicates the slot is empty. 1 = Indicates the slot has a device connected. Otherwise, if XCAP.SI is cleared, this bit is always set (1).
5	MRL Sensor State (MS) — Reserved as the MRL sensor is not implemented.
4	Command Completed (CC) — R/WC. 0 = Issued command not completed. 1 = The Hot-Plug controller completed an issued command. This is set when the last message of a command is sent and indicates that software can write a new command to the slot controller.
3	Presence Detect Changed (PDC) — R/WC. 0 = No change in the PDS bit. 1 = The PDS bit changed states.
2	MRL Sensor Changed (MSC) — Reserved as the MRL sensor is not implemented.
1	Power Fault Detected (PFD) — Reserved as a power controller is not implemented.
0	Attention Button Pressed (ABP) — R/WC. 0 = The attention button has not been pressed. 1 = The attention button is pressed.

19.1.33 RCTL—Root Control Register (PCI Express—D28:F0/F1/F2/F3)

Address Offset: 5C–5Dh Attribute: R/W
 Default Value: 0000h Size: 16 bits

Bit	Description
15:4	Reserved
3	PME Interrupt Enable (PIE) — R/W. 0 = Interrupt generation disabled. 1 = Interrupt generation enabled when PCISTS.Inerrupt Status (D28:F0/F1/F2/F3:60h, bit-16) is in a set state (either due to a 0 to 1 transition, or due to this bit being set with RSTS.IS already set).
2	System Error on Fatal Error Enable (SFE) — R/W. 0 = An SERR# will not be generated. 1 = An SERR# will be generated, assuming CMD.SEE (D28:F0/F1/F2/F3:04, bit 8) is set, if a fatal error is reported by any of the devices in the hierarchy of this root port, including fatal errors in this root port.
1	System Error on Non-Fatal Error Enable (SNE) — R/W. 0 = An SERR# will not be generated. 1 = An SERR# will be generated, assuming CMD.SEE (D28:F0/F1/F2/F3:04, bit 8) is set, if a non-fatal error is reported by any of the devices in the hierarchy of this root port, including non-fatal errors in this root port.
0	System Error on Correctable Error Enable (SCE) — R/W. 0 = An SERR# will not be generated. 1 = An SERR# will be generated, assuming CMD.SEE (D28:F0/F1/F2/F3:04, bit 8) if a correctable error is reported by any of the devices in the hierarchy of this root port, including correctable errors in this root port.

19.1.34 RSTS—Root Status Register (PCI Express—D28:F0/F1/F2/F3)

Address Offset: 60–63h Attribute: R/WC, RO
 Default Value: 00000000h Size: 32 bits

Bit	Description
31:18	Reserved
17	PME Pending (PP) — RO. 0 = When the original PME is cleared by software, it will be set again, the requestor ID will be updated, and this bit will be cleared. 1 = Indicates another PME is pending when the PME status bit is set.
16	PME Status (PS) — R/WC. 0 = PME was not asserted. 1 = Indicates that PME was asserted by the requestor ID in RID. Subsequent PMEs are kept pending until this bit is cleared.
15:0	PME Requestor ID (RID) — RO. Indicates the PCI requestor ID of the last PME requestor. Valid only when PS is set.

19.1.38 MD—Message Signaled Interrupt Message Data Register (PCI Express—D28:F0/F1/F2/F3)

Address Offset: 88–89h Attribute: R/W
Default Value: 0000h Size: 16 bits

Bit	Description
15:0	Data (DATA) — R/W. This 16-bit field is programmed by system software if MSI is enabled. Its content is driven onto the lower word (PCI AD[15:0]) during the data phase of the MSI memory write transaction.

19.1.39 SVCAP—Subsystem Vendor Capability Register (PCI Express—D28:F0/F1/F2/F3)

Address Offset: 90–91h Attribute: RO
Default Value: A00Dh Size: 16 bits

Bit	Description
15:8	Next Capability (NEXT) — RO. This field indicates the location of the next pointer in the list.
7:0	Capability Identifier (CID) — RO. Value of 0Dh indicates this is a PCI bridge subsystem vendor capability.

19.1.40 SVID—Subsystem Vendor Identification Register (PCI Express—D28:F0/F1/F2/F3)

Address Offset: 94–97h Attribute: R/WO
Default Value: 00000000h Size: 32 bits

Bit	Description
31:16	Subsystem Identifier (SID) — R/WO. This field indicates the subsystem as identified by the vendor. This field is write once and is locked down until a bridge reset occurs (not the PCI bus reset).
15:0	Subsystem Vendor Identifier (SVID) — R/WO. This field indicates the manufacturer of the subsystem. This field is write once and is locked down until a bridge reset occurs (not the PCI bus reset).

19.1.41 PMCAP—Power Management Capability Register (PCI Express—D28:F0/F1/F2/F3)

Address Offset: A0–A1h Attribute: RO
Default Value: 0001h Size: 16 bits

Bit	Description
15:8	Next Capability (NEXT) — RO. This field indicates this is the last item in the list.
7:0	Capability Identifier (CID) — RO. Value of 01h indicates this is a PCI power management capability.

19.1.42 PMC—PCI Power Management Capabilities Register (PCI Express—D28:F0/F1/F2/F3)

Address Offset: A2–A3h Attribute: RO
Default Value: C802h Size: 16 bits

Bit	Description
15:11	PME_Support (PMES) — RO. This field indicates PME# is supported for states D0, D3 _{HOT} and D3 _{COLD} . The root port does not generate PME#, but reporting that it does is necessary for some legacy operating systems to enable PME# in devices connected behind this root port.
10	D2_Support (D2S) — RO. The D2 state is not supported.
9	D1_Support (D1S) — RO The D1 state is not supported.
8:6	Aux_Current (AC) — RO. Reports 375 mA maximum suspend well current required when in the D3 _{COLD} state.
5	Device Specific Initialization (DSI) — RO. This bit indicates that no device-specific initialization is required.
4	Reserved
3	PME Clock (PMEC) — RO. This bit indicates that PCI clock is not required to generate PME#.
2:0	Version (VS) — RO. This field indicates support for <i>Revision 1.1 of the PCI Power Management Specification</i> .

19.1.45 SMSCS—SMI/SCI Status Register (PCI Express—D28:F0/F1/F2/F3)

Address Offset: DC-DFh Attribute: R/WC
 Default Value: 00000000h Size: 32 bits

Bit	Description
31	Power Management SCI Status (PMCS) — R/WC. This bit is set if the Hot-Plug controller needs to generate an interrupt, and this interrupt has been routed to generate an SCI.
30	Hot Plug SCI Status (HPCS) — R/WC. This bit is set if the Hot-Plug controller needs to generate an interrupt, and has this interrupt been routed to generate an SCI.
29:4	Reserved
3	Hot Plug Command Completed SMI Status (HPCCM) — R/WC. This bit is set when SLSTS.CC (D28:F0/F1/F2/F3:5A, bit 4) transitions from 0 to 1, and MPC.HPME (D28:F0/F1/F2/F3:D8, bit 1) is set. When this bit is set, an SMI# will be generated.
2	Hot Plug Attention Button SMI Status (HPABM) — R/WC. This bit is set when SLSTS.ABP (D28:F0/F1/F2/F3:5A, bit 0) transitions from 0 to 1, and MPC.HPME (D28:F0/F1/F2/F3:D8, bit 1) is set. When this bit is set, an SMI# will be generated.
1	Hot Plug Presence Detect SMI Status (HPPDM) — R/WC. This bit is set when SLSTS.PDC (D28:F0/F1/F2/F3:5A, bit 3) transitions from 0 to 1, and MPC.HPME (D28:F0/F1/F2/F3:D8, bit 1) is set. When this bit is set, an SMI# will be generated.
0	Power Management SMI Status (PMMS) — R/WC. This bit is set when RSTS.PS (D28:F0/F1/F2/F3:60, bit 16) transitions from 0 to 1, and MPC.PMME (D28:F0/F1/F2/F3:D8, bit 1) is set.

19.1.46 VCH—Virtual Channel Capability Header Register (PCI Express—D28:F0/F1/F2/F3)

Address Offset: 100-103h Attribute: RO
 Default Value: 18010002h Size: 32 bits

Bit	Description
31:20	Next Capability Offset (NCO) — RO. This field indicates the next item in the list.
19:16	Capability Version (CV) — RO. This field indicates this is version 1 of the capability structure by the PCI SIG.
15:0	Capability ID (CID) — RO. This field indicates this is the Virtual Channel capability item.

19.1.47 VCAP2—Virtual Channel Capability 2 Register (PCI Express—D28:F0/F1/F2/F3)

Address Offset: 108-10Bh Attribute: RO
 Default Value: 00000001h Size: 32 bits

Bit	Description
31:24	VC Arbitration Table Offset (ATO) — RO. This field indicates that no table is present for VC arbitration since it is fixed.
23:0	Reserved.

19.1.48 PVC—Port Virtual Channel Control Register (PCI Express—D28:F0/F1/F2/F3)

Address Offset: 10C–10Dh Attribute: R/W
 Default Value: 0000h Size: 16 bits

Bit	Description
15:4	Reserved.
3:1	VC Arbitration Select (AS) — R/W. This field indicates which VC should be programmed in the VC arbitration table. The root port takes no action on the setting of this field since there is no arbitration table.
0	Load VC Arbitration Table (LAT) — R/W. This bit indicates that the table programmed should be loaded into the VC arbitration table. This bit always returns 0 when read.

19.1.49 PVS — Port Virtual Channel Status Register (PCI Express—D28:F0/F1/F2/F3)

Address Offset: 10E–10Fh Attribute: RO
 Default Value: 0000h Size: 16 bits

Bit	Description
15:1	Reserved.
0	VC Arbitration Table Status (VAS) — RO. This bit indicates the coherency status of the VC Arbitration table when it is being updated. This field is always 0 in the root port since there is no VC arbitration table.

19.1.50 V0CAP — Virtual Channel 0 Resource Capability Register (PCI Express—D28:F0/F1/F2/F3)

Address Offset: 110–113h Attribute: RO
 Default Value: 00000001h Size: 32 bits

Bit	Description
31:24	Port Arbitration Table Offset (AT) — RO. This VC implements no port arbitration table since the arbitration is fixed.
23	Reserved.
22:16	Maximum Time Slots (MTS) — RO. This VC implements fixed arbitration, and therefore this field is not used.
15	Reject Snoop Transactions (RTS) — RO. This VC must be able to take snoopable transactions.
14	Advanced Packet Switching (APS) — RO. This VC is capable of all transactions, not just advanced packet switching transactions.
13:8	Reserved.
7:0	Port Arbitration Capability (PAC) — RO. This field indicates that this VC uses fixed port arbitration.

19.1.51 V0CTL — Virtual Channel 0 Resource Control Register (PCI Express—D28:F0/F1/F2/F3)

Address Offset: 114–117h Attribute: R/W, RO
 Default Value: 80000FFh Size: 32 bits

Bit	Description
31	Virtual Channel Enable (EN) — RO. Always set to 1. Virtual Channel 0 cannot be disabled.
30:27	Reserved.
26:24	Virtual Channel Identifier (VCID) — RO. Indicates the ID to use for this virtual channel.
23:20	Reserved.
19:17	Port Arbitration Select (PAS) — R/W. This field indicates which port table is being programmed. The root complex takes no action on this setting since the arbitration is fixed and there is no arbitration table.
16	Load Port Arbitration Table (LAT) — RO. The root port does not implement an arbitration table for this virtual channel.
15:8	Reserved.
7:1	Transaction Class / Virtual Channel Map (TVM) — R/W. This field indicates which transaction classes are mapped to this virtual channel. When a bit is set, this transaction class is mapped to the virtual channel.
	Bit Transaction Class
	7 Transaction Class 7
	6 Transaction Class 6
	5 Transaction Class 5
	4 Transaction Class 4
	3 Transaction Class 3
	2 Transaction Class 2
1 Transaction Class 1	
0 Transaction Class 0	
0	Reserved. Transaction class 0 must always mapped to VC0.

19.1.52 V0STS — Virtual Channel 0 Resource Status Register (PCI Express—D28:F0/F1/F2/F3)

Address Offset: 11A–11Bh Attribute: RO
 Default Value: 0000h Size: 16 bits

Bit	Description
15:2	Reserved.
1	VC Negotiation Pending (NP) — RO. 0 = Negotiation is not pending. 1 = Indicates the Virtual Channel is still being negotiated with ingress ports.
0	Port Arbitration Tables Status (ATS). There is no port arbitration table for this VC, so this bit is reserved as 0.

19.1.53 UES — Uncorrectable Error Status Register (PCI Express—D28:F0/F1/F2/F3)

Address Offset: 144–147h Attribute: R/WC, RO
 Default Value: 00000000000x0xxx0x0x000000x0000bSize:32 bits

This register maintains its state through a platform reset. It loses its state upon suspend.

Bit	Description
31:21	Reserved
20	Unsupported Request Error Status (URE) — R/WC. This bit indicates an unsupported request was received.
19	ECRC Error Status (EE) — RO. ECRC is not supported.
18	Malformed TLP Status (MT) — R/WC. This bit indicates a malformed TLP was received.
17	Receiver Overflow Status (RO) — R/WC. This bit indicates a receiver overflow occurred.
16	Unexpected Completion Status (UC) — R/WC. This bit indicates an unexpected completion was received.
15	Completion Abort Status (CA) — R/WC. This bit indicates a completer abort was received.
14	Completion Timeout Status (CT) — R/WC. This bit indicates a completion timed out.
13	Flow Control Protocol Error Status (FCPE) — RO. Flow Control Protocol Errors not supported.
12	Poisoned TLP Status (PT) — R/WC. This bit indicates a poisoned TLP was received.
11:5	Reserved
4	Data Link Protocol Error Status (DLPE) — R/WC. This bit indicates a data link protocol error occurred.
3:1	Reserved
0	Training Error Status (TE) — RO. Training Errors not supported.

19.1.54 UEM — Uncorrectable Error Mask (PCI Express—D28:F0/F1/F2/F3)

Address Offset: 148–14Bh Attribute: R/WO, RO
 Default Value: 00000000h Size: 32 bits

When set, the corresponding error in the UES register is masked, and the logged error will cause no action. When cleared, the corresponding error is enabled.

Bit	Description
31:21	Reserved
20	Unsupported Request Error Mask (URE) — R/WO. 0 = The corresponding error in the UES register (D28:F0/F1/F2/F3:144) is enabled. 1 = The corresponding error in the UES register (D28:F0/F1/F2/F3:144) is masked.
19	ECRC Error Mask (EE) — RO. ECRC is not supported.
18	Malformed TLP Mask (MT) — R/WO. 0 = The corresponding error in the UES register (D28:F0/F1/F2/F3:144) is enabled. 1 = The corresponding error in the UES register (D28:F0/F1/F2/F3:144) is masked.
17	Receiver Overflow Mask (RO) — R/WO. 0 = The corresponding error in the UES register (D28:F0/F1/F2/F3:144) is enabled. 1 = The corresponding error in the UES register (D28:F0/F1/F2/F3:144) is masked.
16	Unexpected Completion Mask (UC) — R/WO. 0 = The corresponding error in the UES register (D28:F0/F1/F2/F3:144) is enabled. 1 = The corresponding error in the UES register (D28:F0/F1/F2/F3:144) is masked.
15	Completion Abort Mask (CA) — R/WO. 0 = The corresponding error in the UES register (D28:F0/F1/F2/F3:144) is enabled. 1 = The corresponding error in the UES register (D28:F0/F1/F2/F3:144) is masked.
14	Completion Timeout Mask (CT) — R/WO. 0 = The corresponding error in the UES register (D28:F0/F1/F2/F3:144) is enabled. 1 = The corresponding error in the UES register (D28:F0/F1/F2/F3:144) is masked.
13	Flow Control Protocol Error Mask (FCPE) — RO. Flow Control Protocol Errors not supported.
12	Poisoned TLP Mask (PT) — R/WO. 0 = The corresponding error in the UES register (D28:F0/F1/F2/F3:144) is enabled. 1 = The corresponding error in the UES register (D28:F0/F1/F2/F3:144) is masked.
11:5	Reserved
4	Data Link Protocol Error Mask (DLPE) — R/WO. 0 = The corresponding error in the UES register (D28:F0/F1/F2/F3:144) is enabled. 1 = The corresponding error in the UES register (D28:F0/F1/F2/F3:144) is masked.
3:1	Reserved
0	Training Error Mask (TE) — RO. Training Errors not supported

19.1.55 UEV — Uncorrectable Error Severity (PCI Express—D28:F0/F1/F2/F3)

Address Offset: 14C–14Fh Attribute: RO
 Default Value: 00060011h Size: 32 bits

Bit	Description
31:21	Reserved
20	Unsupported Request Error Severity (URE) — RO. 0 = Error considered non-fatal. (Default) 1 = Error is fatal.
19	ECRC Error Severity (EE) — RO. ECRC is not supported.
18	Malformed TLP Severity (MT) — RO. 0 = Error considered non-fatal. 1 = Error is fatal. (Default)
17	Receiver Overflow Severity (RO) — RO. 0 = Error considered non-fatal. 1 = Error is fatal. (Default)
16	Unexpected Completion Severity (UC) — RO. 0 = Error considered non-fatal. (Default) 1 = Error is fatal.
15	Completion Abort Severity (CA) — RO. 0 = Error considered non-fatal. (Default) 1 = Error is fatal.
14	Completion Timeout Severity (CT) — RO. 0 = Error considered non-fatal. (Default) 1 = Error is fatal.
13	Flow Control Protocol Error Severity (FCPE) — RO. Flow Control Protocol Errors not supported.
12	Poisoned TLP Severity (PT) — RO. 0 = Error considered non-fatal. (Default) 1 = Error is fatal.
11:5	Reserved
4	Data Link Protocol Error Severity (DLPE) — RO. 0 = Error considered non-fatal. 1 = Error is fatal. (Default)
3:1	Reserved
0	Training Error Severity (TE) — RO. TE is not supported.

19.1.56 CES — Correctable Error Status Register (PCI Express—D28:F0/F1/F2/F3)

Address Offset: 150–153h Attribute: R/WC
 Default Value: 00000000h Size: 32 bits

Bit	Description
31:13	Reserved
12	Replay Timer Timeout Status (RTT) — R/WC. This bit indicates the replay timer timed out.
11:9	Reserved
8	Replay Number Rollover Status (RNR) — R/WC. This bit indicates the replay number rolled over.
7	Bad DLLP Status (BD) — R/WC. This bit indicates a bad DLLP was received.
6	Bad TLP Status (BT) — R/WC. This bit indicates a bad TLP was received.
5:1	Reserved
0	Receiver Error Status (RE) — R/WC. This bit indicates a receiver error occurred.

19.1.57 CEM — Correctable Error Mask Register (PCI Express—D28:F0/F1/F2/F3)

Address Offset: 154–157h Attribute: R/WO
 Default Value: 00000000h Size: 32 bits

When set, the corresponding error in the CES register is masked, and the logged error will cause no action. When cleared, the corresponding error is enabled.

Bit	Description
31:13	Reserved
12	Replay Timer Timeout Mask (RTT) — R/WO. Mask for replay timer timeout.
11:9	Reserved
8	Replay Number Rollover Mask (RNR) — R/WO. Mask for replay number rollover.
7	Bad DLLP Mask (BD) — R/WO. Mask for bad DLLP reception.
6	Bad TLP Mask (BT) — R/WO. Mask for bad TLP reception.
5:1	Reserved
0	Receiver Error Mask (RE) — R/WO. Mask for receiver errors.

19.1.58 AECC — Advanced Error Capabilities and Control Register (PCI Express—D28:F0/F1/F2/F3)

Address Offset: 158–15Bh Attribute: RO
 Default Value: 00000000h Size: 32 bits

Bit	Description
31:9	Reserved
8	ECRC Check Enable (ECE) — RO. ECRC is not supported.
7	ECRC Check Capable (ECC) — RO. ECRC is not supported.
6	ECRC Generation Enable (EGE) — RO. ECRC is not supported.
5	ECRC Generation Capable (EGC) — RO. ECRC is not supported.
4:0	First Error Pointer (FEP) — RO.

19.1.59 RES — Root Error Status Register (PCI Express—D28:F0/F1/F2/F3)

Address Offset: 170–173h Attribute: R/WC, RO
 Default Value: 00000000h Size: 32 bits

Bit	Description
31:27	Advanced Error Interrupt Message Number (AEMN) — RO. There is only one error interrupt allocated.
26:4	Reserved
3	Multiple ERR_FATAL/NONFATAL Received (MENR) — RO. For Intel® ICH6, only one error will be captured.
2	ERR_FATAL/NONFATAL Received (ENR) — R/WC. 0 = No error message received. 1 = Either a fatal or a non-fatal error message is received.
1	Multiple ERR_COR Received (MCR) — RO. For ICH6, only one error will be captured.
0	ERR_COR Received (CR) — R/WC. 0 = No error message received. 1 = A correctable error message is received.

19.1.60 RCTCL — Root Complex Topology Capability List Register (PCI Express—D28:F0/F1/F2/F3)

Address Offset: 180–183h Attribute: RO
 Default Value: 00010005h Size: 32 bits

Bit	Description
31:20	Next Capability (NEXT) — RO. This field indicates the next item in the list, in this case, end of list.
19:16	Capability Version (CV) — RO. This field indicates the version of the capability structure.
15:0	Capability ID (CID) — RO. This field indicates is a root complex topology capability.

19.1.61 ESD — Element Self Description Register (PCI Express—D28:F0/F1/F2/F3)

Address Offset: 184–187h Attribute: RO
 Default Value: See Description Size: 32 bits

Bit	Description										
31:24	<p>Port Number (PN) — RO. This field indicates the ingress port number for the root port. There is a different value per port:</p> <table border="1"> <thead> <tr> <th>Port #</th> <th>Value</th> </tr> </thead> <tbody> <tr> <td>1</td> <td>01h</td> </tr> <tr> <td>2</td> <td>02h</td> </tr> <tr> <td>3</td> <td>03h</td> </tr> <tr> <td>4</td> <td>04h</td> </tr> </tbody> </table>	Port #	Value	1	01h	2	02h	3	03h	4	04h
Port #	Value										
1	01h										
2	02h										
3	03h										
4	04h										
23:16	<p>Component ID (CID) — RO. This field returns the value of the ESD.CID field (Chipset Configuration Space:Offset 0104h:bits 23:16) of the chip configuration section, that is programmed by platform BIOS, since the root port is in the same component as the RCRB.</p>										
15:8	<p>Number of Link Entries (NLE) — RO. (Default value is 01h) Indicates one link entry (corresponding to the RCRB).</p>										
7:4	Reserved.										
3:0	<p>Element Type (ET) — RO. (Default value is 0h) Indicates that the element type is a root port.</p>										

19.1.62 ULD — Upstream Link Description Register (PCI Express—D28:F0/F1/F2/F3)

Address Offset: 190–193h Attribute: RO
 Default Value: 00000001h Size: 32 bits

Bit	Description
31:24	<p>Target Port Number (PN) — RO. Indicates the port number of the RCRB.</p>
23:16	<p>Target Component ID (TCID) — RO. This field returns the value of the ESD.CID field (Chipset Configuration Space:Offset 0104h:bits 23:16) of the chip configuration section, that is programmed by platform BIOS, since the root port is in the same component as the RCRB.</p>
15:2	Reserved.
1	<p>Link Type (LT) — RO. Indicates that the link points to the ICH6 RCRB.</p>
0	<p>Link Valid (LV) — RO. Indicates that this link entry is valid.</p>

19.1.63 ULBA — Upstream Link Base Address Register (PCI Express—D28:F0/F1/F2/F3)

Address Offset: 198–19Fh Attribute: RO
 Default Value: See Description Size: 64 bits

Bit	Description
63:32	Base Address Upper (BAU) — RO. The RCRB of the ICH6 lives in 32-bit space.
31:0	Base Address Lower (BAL) — RO. This field matches the RCBA register (D31:F0:Offset F0h) value in the LPC bridge.

19.1.64 PCIECR1 — PCI Express Configuration Register 1 (PCI Express—D28:F0/F1/F2/F3)

Address Offset: 314h Attribute: R/W
 Default Value: 0A200000h Size: 32 bits

Bit	Description
31:28	PCI Express Configuration Bits [31:28] (PCIECB:31:28) — R/W. Refer to the ICH6 BIOS Specification for programming of this field.
23:0	Reserved

19.1.65 PCIECR2 — PCI Express Configuration Register 2 (PCI Express—D28:F0/F1/F2/F3)

Address Offset: 318h Attribute: R/W
 Default Value: 0A200000h Size: 32 bits

Bit	Description
31:24	PCI Express Configuration Bits [31:24] (PCIECB:31:24) — R/W. Refer to the ICH6 BIOS Specification for programming of this field.
23:0	Reserved

§



20 High Precision Event Timer Registers

The timer registers are memory-mapped in a non-indexed scheme. This allows the processor to directly access each register without having to use an index register. The timer register space is 1024 bytes. The registers are generally aligned on 64-bit boundaries to simplify implementation with IA64 processors. There are four possible memory address ranges beginning at 1) FED0_0000h, 2) FED0_1000h, 3) FED0_2000h., 4) FED0_4000h. The choice of address range will be selected by configuration bits in the High Precision Timer Configuration Register (Chipset Configuration Registers:Offset 3404h).

Behavioral Rules:

1. Software must not attempt to read or write across register boundaries. For example, a 32-bit access should be to offset x0h, x4h, x8h, or xCh. 32-bit accesses should not be to 01h, 02h, 03h, 05h, 06h, 07h, 09h, 0Ah, 0Bh, 0Dh, 0Eh, or 0Fh. Any accesses to these offsets will result in an unexpected behavior, and may result in a master abort. However, these accesses should not result in system hangs. 64-bit accesses can only be to x0h and must not cross 64-bit boundaries.
2. Software should not write to read-only registers.
3. Software should not expect any particular or consistent value when reading reserved registers or bits.

20.1 Memory Mapped Registers

Table 20-1. Memory-Mapped Registers

Offset	Mnemonic	Register	Default	Type
000–007h	GCAP_ID	General Capabilities and Identification	0429B17F80 86A201h	RO
008–00Fh	—	Reserved	—	—
010–017h	GEN_CONF	General Configuration	0000h	R/W
018–01Fh	—	Reserved	—	—
020–027h	GINTR_STA	General Interrupt Status	00000000 00000000h	R/WC, R/W
028–0EFh	—	Reserved	—	—
0F0–0F7h	MAIN_CNT	Main Counter Value	N/A	R/W
0F8–0FFh	—	Reserved	—	—
100–107h	TIM0_CONF	Timer 0 Configuration and Capabilities	N/A	R/W, RO
108–10Fh	TIM0_COMP	Timer 0 Comparator Value	N/A	R/W
110–11Fh	—	Reserved	—	—
120–127h	TIM1_CONF	Timer 1 Configuration and Capabilities	N/A	R/W, RO
128–12Fh	TIM1_COMP	Timer 1 Comparator Value	N/A	R/W
130–13Fh	—	Reserved	—	—
140–147h	TIM2_CONF	Timer 2 Configuration and Capabilities	N/A	R/W, RO
148–14Fh	TIM2_COMP	Timer 2 Comparator Value	N/A	R/W
150–15Fh	—	Reserved	—	—
160–3FFh	—	Reserved	—	—

NOTES:

1. Reads to reserved registers or bits will return a value of 0.
2. Software must not attempt locks to the memory-mapped I/O ranges for High Precision Event Timers. If attempted, the lock is not honored, which means potential deadlock conditions may occur.

20.1.1 GCAP_ID—General Capabilities and Identification Register

Address Offset: 00h Attribute: RO
 Default Value: 0429B17F8086A201h Size: 64 bits

Bit	Description
63:32	Main Counter Tick Period (COUNTER_CLK_PER_CAP) — RO. This field indicates the period at which the counter increments in femtoseconds (10 ⁻¹⁵ seconds). This will return 0429B17F when read. This indicates a period of 69841279 fs (69.841279 ns).
31:16	Vendor ID Capability (VENDOR_ID_CAP) — RO. This is a 16-bit value assigned to Intel.
15	Legacy Replacement Rout Capable (LEG_RT_CAP) — RO. Hardwired to 1. Legacy Replacement Interrupt Rout option is supported.
14	Reserved. This bit returns 0 when read.
13	Counter Size Capability (COUNT_SIZE_CAP) — RO. Hardwired to 1. Counter is 64-bit wide.
12:8	Number of Timer Capability (NUM_TIM_CAP) — RO. This field indicates the number of timers in this block. 02h = Three timers.
7:0	Revision Identification (REV_ID) — RO. This indicates which revision of the function is implemented. Default value will be 01h.

20.1.2 GEN_CONF—General Configuration Register

Address Offset: 010h Attribute: R/W
 Default Value: 0000000000000000h Size: 64 bits

Bit	Description
63:2	Reserved. These bits return 0 when read.
1	<p>Legacy Replacement Rout (LEG_RT_CNF) — R/W. If the ENABLE_CNF bit and the LEG_RT_CNF bit are both set, then the interrupts will be routed as follows:</p> <ul style="list-style-type: none"> • Timer 0 is routed to IRQ0 in 8259 or IRQ2 in the I/O APIC • Timer 1 is routed to IRQ8 in 8259 or IRQ8 in the I/O APIC • Timer 2-n is routed as per the routing in the timer n configuration registers. • If the Legacy Replacement Rout bit is set, the individual routing bits for Timers 0 and 1 (APIC) will have no impact. • If the Legacy Replacement Rout bit is not set, the individual routing bits for each of the timers are used. • This bit will default to 0. BIOS can set it to 1 to enable the legacy replacement routing, or 0 to disable the legacy replacement routing.
0	<p>Overall Enable (ENABLE_CNF) — R/W. This bit must be set to enable any of the timers to generate interrupts. If this bit is 0, then the main counter will halt (will not increment) and no interrupts will be caused by any of these timers. For level-triggered interrupts, if an interrupt is pending when the ENABLE_CNF bit is changed from 1 to 0, the interrupt status indications (in the various Txx_INT_STS bits) will not be cleared. Software must write to the Txx_INT_STS bits to clear the interrupts.</p> <p>NOTE: This bit will default to 0. BIOS can set it to 1 or 0.</p>

20.1.3 GINTR_STA—General Interrupt Status Register

Address Offset: 020h Attribute: R/W, R/WC
 Default Value: 0000000000000000h Size: 64 bits

Bit	Description
63:3	Reserved. These bits will return 0 when read.
2	Timer 2 Interrupt Active (T02_INT_STS) — R/W. Same functionality as Timer 0.
1	Timer 1 Interrupt Active (T01_INT_STS) — R/W. Same functionality as Timer 0.
0	<p>Timer 0 Interrupt Active (T00_INT_STS) — R/WC. The functionality of this bit depends on whether the edge or level-triggered mode is used for this timer. (default = 0)</p> <p>If set to level-triggered mode: This bit will be set by hardware if the corresponding timer interrupt is active. Once the bit is set, it can be cleared by software writing a 1 to the same bit position. Writes of 0 to this bit will have no effect.</p> <p>If set to edge-triggered mode: This bit should be ignored by software. Software should always write 0 to this bit.</p> <p>NOTE: Defaults to 0. In edge triggered mode, this bit will always read as 0 and writes will have no effect.</p>

20.1.4 MAIN_CNT—Main Counter Value Register

Address Offset: 0F0h Attribute: R/W
 Default Value: N/A Size: 64 bits

Bit	Description
63:0	<p>Counter Value (COUNTER_VAL[63:0]) — R/W. Reads return the current value of the counter. Writes load the new value to the counter.</p> <p>NOTES:</p> <ol style="list-style-type: none"> 1. Writes to this register should only be done while the counter is halted. 2. Reads to this register return the current value of the main counter. 3. 32-bit counters will always return 0 for the upper 32-bits of this register. 4. If 32-bit software attempts to read a 64-bit counter, it should first halt the counter. Since this delays the interrupts for all of the timers, this should be done only if the consequences are understood. It is strongly recommended that 32-bit software only operate the timer in 32-bit mode. 5. Reads to this register are monotonic. No two consecutive reads return the same value. The second of two reads always returns a larger value (unless the timer has rolled over to 0).

20.1.5 TIM_n_CONF—Timer n Configuration and Capabilities Register

Address Offset:	Timer 0: 100–107h, Timer 1: 120–127h, Timer 2: 140–147h	Attribute:	RO, R/W
Default Value:	N/A	Size:	64 bits

Note: The letter n can be 0, 1, or 2, referring to Timer 0, 1 or 2.

Bit	Description
63:56	Reserved. These bits will return 0 when read.
55:52, 43	<p>Timer Interrupt Rout Capability (TIMER_n_INT_ROUT_CAP) — RO.</p> <p>Timer 0, 1: Bits 52, 53, 54, and 55 in this field (corresponding to IRQ 20, 21, 22, and 23) have a value of 1. Writes will have no effect.</p> <p>Timer 2: Bits 43, 52, 53, 54, and 55 in this field (corresponding to IRQ 11, 20, 21, 22, and 23) have a value of 1. Writes will have no effect.</p> <p>NOTE: If IRQ 11 is used for HPET #2, software should ensure IRQ 11 is not shared with any other devices to guarantee the proper operation of HPET #2.</p>
51:44, 42:14	Reserved. These bits return 0 when read.
13:9	<p>Interrupt Rout (TIMER_n_INT_ROUT_CNF) — R/W. This 5-bit field indicates the routing for the interrupt to the I/O (x) APIC. Software writes to this field to select which interrupt in the I/O (x) will be used for this timer's interrupt. If the value is not supported by this particular timer, then the value read back will not match what is written. The software must only write valid values.</p> <p>NOTES:</p> <ol style="list-style-type: none"> If the Legacy Replacement Rout bit is set, then Timers 0 and 1 will have a different routing, and this bit field has no effect for those two timers. Timer 0, 1: Software is responsible to make sure it programs a valid value (20, 21, 22, or 23) for this field. The ICH6 logic does not check the validity of the value written. Timer 2: Software is responsible to make sure it programs a valid value (11, 20, 21, 22, or 23) for this field. The ICH6 logic does not check the validity of the value written.
8	<p>Timer n 32-bit Mode (TIMER_n_32MODE_CNF) — R/W or RO. Software can set this bit to force a 64-bit timer to behave as a 32-bit timer.</p> <p>Timer 0: Bit is read/write (default to 0). 1 = 64 bit; 0 = 32 bit</p> <p>Timers 1, 2: Hardwired to 0. Writes have no effect (since these two timers are 32-bits).</p>
7	Reserved. This bit returns 0 when read.
6	<p>Timer n Value Set (TIMER_n_VAL_SET_CNF) — R/W. Software uses this bit only for Timer 0 if it has been set to periodic mode. By writing this bit to a 1, the software is then allowed to directly set the timer's accumulator. Software does not have to write this bit back to 1 (it automatically clears). Software should not write a 1 to this bit position if the timer is set to non-periodic mode.</p> <p>NOTE: This bit will return 0 when read. Writes will only have an effect for Timer 0 if it is set to periodic mode. Writes will have no effect for Timers 1 and 2.</p>
5	<p>Timer n Size (TIMER_n_SIZE_CAP) — RO. This read only field indicates the size of the timer.</p> <p>Timer 0: Value is 1 (64-bits).</p> <p>Timers 1, 2: Value is 0 (32-bits).</p>
4	<p>Periodic Interrupt Capable (TIMER_n_PER_INT_CAP) — RO. If this bit is 1, the hardware supports a periodic mode for this timer's interrupt.</p> <p>Timer 0: Hardwired to 1 (supports the periodic interrupt).</p> <p>Timers 1, 2: Hardwired to 0 (does not support periodic interrupt).</p>

Bit	Description
3	<p>Timer n Type (TIMERn_TYPE_CNF) — R/W or RO.</p> <p>Timer 0: Bit is read/write. 0 = Disable timer to generate periodic interrupt; 1 = Enable timer to generate a periodic interrupt.</p> <p>Timers 1, 2: Hardwired to 0. Writes have no affect.</p>
2	<p>Timer n Interrupt Enable (TIMERn_INT_ENB_CNF) — R/W. This bit must be set to enable timer n to cause an interrupt when it times out.</p> <p>1 = Enable.</p> <p>0 = Disable (Default). The timer can still count and generate appropriate status bits, but will not cause an interrupt.</p>
1	<p>Timer Interrupt Type (TIMERn_INT_TYPE_CNF) — R/W.</p> <p>0 = The timer interrupt is edge triggered. This means that an edge-type interrupt is generated. If another interrupt occurs, another edge will be generated.</p> <p>1 = The timer interrupt is level triggered. This means that a level-triggered interrupt is generated. The interrupt will be held active until it is cleared by writing to the bit in the General Interrupt Status Register. If another interrupt occurs before the interrupt is cleared, the interrupt will remain active.</p>
0	Reserved. These bits will return 0 when read.

NOTE: Reads or writes to unimplemented timers should not be attempted. Read from any unimplemented registers will return an undetermined value.

20.1.6 TIMn_COMP—Timer n Comparator Value Register

Address Offset: Timer 0: 108h–10Fh,
 Timer 1: 128h–12Fh,
 Timer 2: 148h–14Fh
 Attribute: R/W
 Default Value: N/A
 Size: 64 bit

Bit	Description
63:0	<p>Timer Compare Value — R/W. Reads to this register return the current value of the comparator Timers 0, 1, or 2 are configured to non-periodic mode: Writes to this register load the value against which the main counter should be compared for this timer.</p> <ul style="list-style-type: none"> • When the main counter equals the value last written to this register, the corresponding interrupt can be generated (if so enabled). • The value in this register does not change based on the interrupt being generated. <p>Timer 0 is configured to periodic mode:</p> <ul style="list-style-type: none"> • When the main counter equals the value last written to this register, the corresponding interrupt can be generated (if so enabled). • After the main counter equals the value in this register, the value in this register is increased by the value last written to the register. <p>For example, if the value written to the register is 00000123h, then</p> <ol style="list-style-type: none"> 1. An interrupt will be generated when the main counter reaches 00000123h. 2. The value in this register will then be adjusted by the hardware to 00000246h. 3. Another interrupt will be generated when the main counter reaches 00000246h 4. The value in this register will then be adjusted by the hardware to 00000369h <ul style="list-style-type: none"> • As each periodic interrupt occurs, the value in this register will increment. When the incremented value is greater than the maximum value possible for this register (FFFFFFFFh for a 32-bit timer or FFFFFFFFFFFFFFFFh for a 64-bit timer), the value will wrap around through 0. For example, if the current value in a 32-bit timer is FFFF0000h and the last value written to this register is 20000, then after the next interrupt the value will change to 00010000h <p>Default value for each timer is all 1s for the bits that are implemented. For example, a 32-bit timer has a default value of 00000000FFFFFFFFh. A 64-bit timer has a default value of FFFFFFFFFFFFFFFFh.</p>

§



21 *Ballout Definition*

This section contains the Intel® ICH6 ballout information. The ballout is preliminary and subject to change. [Figure 21-1](#) and [Figure 21-2](#) are the ballout map of the 609 BGA package. [Table 21-1](#) is a BGA ball list, sorted alphabetically by signal name.

Note:

- † Throughout this chapter, this symbol indicates a Mobile Only signal
- ‡ Throughout this chapter, this symbol indicates a Desktop Only signal

Figure 21-1. Intel® ICH6 Preliminary Ballout (Topview–Left Side)

	1	2	3	4	5	6	7	8	9	10	11	12	13	14
A	Vss	AD[10]	IRDY#	Vss	AD[29]	Vcc3_3	Vss	V5REF	Vss	ACZ_RST#	VccSus3_3	Vss	VccLAN3_3/ VccSus3_3 [†]	USBP[7]N
B	Vcc3_3	AD[26]	AD[24]	AD[14]	REQ[1]#	GNT[1]#	REQ[6]#/ GPI[0]	REQ[3]#	ACZ_SYNC	ACZ_SDIN[2]	LAN_RSTSYNC	EE_SHCLK	Vss	USBP[7]P
C	GNT[0]#	AD[2]	DEVSEL#	Vss	PLOCK#	PIRQ[G]#/ GPI[4]	PIRQ[F]#/ GPI[3]	GNT[3]#	ACZ_SDOUT	ACZ_BIT_CLK	LAN_TXD[1]	LAN_TXD[0]	LAN_RXD[2]	Vss
D	Vss	AD[11]	AD[9]	AD[18]	AD[12]	AD[7]	Vss	GNT[6]#/ GPI[16]	PIRQ[E]#/ GPI[2]	Vss	EE_DOUT	EE_CS	Vss	Vss
E	PAR	AD[0]	PERR#	Vcc3_3	AD[1]	AD[8]	GNT[4]#/ GPI[48]	REQ[5]#/ GPI[1]	AD[5]	CLK14	LAN_RXD[1]	LAN_RXD[0]	LAN_TXD[2]	Vss
F	GNT[2]#	AD[6]	AD[4]	Vss	AD[3]	GNT[5]#/ GPI[17]	REQ[4]#/ GPI[40]	SPKR	Vcc1_5_A	ACZ_SDIN[1]	ACZ_SDIN[0]	LAN_CLK	EE_DIN	VccLAN3_3/ VccSus3_3 [†]
G	Vss	C/BE[3]#	AD[20]	C/BE[2]#	SERR#	PCICLK	Vss	Vcc1_5_A	Vss	VccLAN1_5/ VccSus1_5 [†]	VccLAN1_5/ VccSus1_5 [†]	Vss	VccLAN3_3/ VccSus3_3 [†]	VccLAN3_3/ VccSus3_3 [†]
H	Vcc3_3	AD[22]	AD[13]	AD[21]	AD[23]	C/BE[1]#	Vcc3_3	VOID	VOID	VOID	VOID	VOID	VOID	VOID
J	STOP#	TRDY#	FRAME#	Vss	AD[15]	C/BE[0]#	Vcc3_3	VOID	VOID	VOID	VOID	VOID	VOID	VOID
K	Vss	AD[16]	AD[28]	AD[31]	AD[17]	AD[27]	Vss	VOID	VOID	VOID	VOID	VOID	VOID	VOID
L	AD[30]	PIRQ[B]#	PIRQ[D]#	Vcc3_3	REQ[0]#	AD[19]	Vcc3_3	VOID	VOID	VOID	Vcc1_5_A	Vcc1_5_A	Vss	Vcc1_5_A
M	PIRQ[C]#	GPI[12]	PIRQ[H]#/ GPI[5]	Vss	REQ[2]#	AD[25]	Vcc3_3	VOID	VOID	VOID	Vcc1_5_A	Vss	Vss	Vss
N	Vss	PIRQ[A]#	LAD[1]/ FWH[1]	LAD[3]/ FWH[3]	LAD[2]/ FWH[2]	LDRQ[0]#	Vss	VOID	VOID	VOID	Vss	Vss	Vss	Vss
P	Vcc3_3	LAD[0]/ FWH[0]	LFRAME#/ FWH[4]	LDRQ[1]#/ GPI[41]	GPI[25]	PME#	Vcc2_5	VOID	VOID	VOID	Vcc1_5_A	Vss	Vss	Vss
R	GPI[8]	PCIRST#	GPI[27]	Vss	PLTRST#	GPI[13]	VccSus1_5	VOID	VOID	VOID	Vss	Vss	Vss	Vss
T	Vss	RI#	GPI[28]	SLP_S3#	SLP_S4#	SLP_S5#	Vss	VOID	VOID	VOID	Vcc1_5_A	Vss	Vss	Vss
U	PWRBTN#	SYS_RESET#	TP[3]	VccSus3_3	WAKE#	SMLINK[1]	VccSus1_5	VOID	VOID	VOID	Vcc1_5_A	Vcc1_5_A	Vss	Vcc1_5_A
V	VccSus3_3	BATLOW#/ TP[0] [†]	GPI[24]	Vss	LAN_RST#	SUSCLK	VccSus3_3	VOID	VOID	VOID	VOID	VOID	VOID	VOID
W	Vss	VccSus3_3	SUS_STAT#/ LPCPD#	SMLINK[0]	SMBDATA	SMBALERT#/ GPI[11]	Vss	VOID	VOID	VOID	VOID	VOID	VOID	VOID
Y	RTCX1	RTCX2	RSMRST#	SMBCLK	LINKALERT#	Vss	VccSus3_3	VOID	VOID	VOID	VOID	VOID	VOID	VOID
AA	PWROK	RTCRST#	INTRUDER#	Vss	INTVRMEN	Vcc1_5_A	Vcc1_5_A	Vcc1_5_A	Vcc1_5_A	Vcc3_3	Vss	Vcc3_3	Vss	Vcc3_3
AB	Vss	Vss	VccRTC	Vcc1_5_A	Vcc1_5_A	Vcc1_5_A	Vss	Vcc1_5_A	Vss	Vss	DD[7]	DD[10]	DD[11]	DDREQ
AC	SATA_CLKP	SATA_CLKN	Vss	Vcc1_5_A	SATA[1]RXN#/ RESERVED [†]	Vss	SATA[2]RXP	Vcc1_5_A	SATA[3]RXN#/ RESERVED [†]	Vss	DD[5]	Vss	DD[12]	DIOV#
AD	Vss	Vss	SATA[0]RXP	Vcc1_5_A	SATA[1]RXP#/ RESERVED [†]	Vss	SATA[2]RXN	Vcc1_5_A	SATA[3]RXP#/ RESERVED [†]	Vss	DD[6]	DD[3]	DD[15]	DD[0]
AE	VccSATAPLL	Vss	SATA[0]RXN	Vcc1_5_A	Vcc1_5_A	Vss	Vss	Vcc1_5_A	Vcc1_5_A	Vss	Vss	Vss	DD[8]	DD[4]
AF	Vss	SATA[0]TXP	Vss	SATA[1]TXN#/ RESERVED [†]	Vcc1_5_A	SATA[2]TXN	Vss	SATA[3]TXN#/ RESERVED [†]	Vcc1_5_A	Vss	SATARBIAS	Vss	DD[9]	DD[2]
AG	Vss	SATA[0]TXN	Vss	SATA[1]TXP#/ RESERVED [†]	Vcc1_5_A	SATA[2]TXP	Vss	SATA[3]TXP#/ RESERVED [†]	Vcc1_5_A	Vcc3_3	SATARBIAS#	Vss	Vcc3_3	Vss

Figure 21-2. Intel® ICH6 Preliminary Ballout (Topview–Right Side)

15	16	17	18	19	20	21	22	23	24	25	26	27	
Vss	USBP[5]P	VccSus3_3	USBP[3]N	Vss	USBP[1]N	Vss	USBRBIAS#	Vss	VccSus3_3	VccUSBPLL	Vss	CLK48	A
Vss	USBP[5]N	VccSus3_3	USBP[3]P	Vss	USBP[1]P	Vss	USBRBIAS	Vss	Vss	Vss	OC[2]#	OC[1]#	B
USBP[6]N	VccSus3_3	VccSus3_3	Vss	USBP[2]P	Vss	USBP[0]N	Vss	OC[4]#/GPI[9]	OC[7]#/GPI[15]	OC[6]#/GPI[14]	OC[3]#	OC[0]#	C
USBP[6]P	VccSus3_3	USBP[4]P	Vss	USBP[2]N	Vss	USBP[0]P	Vss	OC[5]#/GPI[10]	Vcc1_5_A	Vcc1_5_A	Vcc1_5_A	Vcc1_5_A	D
Vss	VccSus3_3	USBP[4]N	Vss	Vss	Vcc1_5_A	Vcc1_5_A	Vcc1_5_A	Vcc1_5_A	Vcc1_5_A	Vss	Vcc3_3	Vss	E
VccSus3_3	VccSus3_3	Vss	VccSus3_3	Vss	Vcc1_5_A	V5REF_Sus	Vss	DML_IRCOMP	DML_ZCOMP	Vcc1_5_B	Vcc1_5_B	Vcc1_5_B	F
VccSus3_3	VccSus3_3	VccSus3_3	VccSus3_3	VccSus1_5	Vcc1_5_A	Vss	Vcc1_5_B	Vcc1_5_B	Vcc1_5_B	Vcc1_5_B	PETp[1]	PETn[1]	G
VOID	VOID	VOID	VOID	VOID	VOID	Vcc1_5_B	Vcc1_5_B	Vss	PERp[1]	PERn[1]	Vss	Vss	H
VOID	VOID	VOID	VOID	VOID	VOID	Vcc1_5_B	Vcc1_5_B	Vss	Vss	Vss	PETp[2]	PETn[2]	J
VOID	VOID	VOID	VOID	VOID	VOID	Vcc1_5_B	Vcc1_5_B	Vss	PERp[2]	PERn[2]	Vss	Vss	K
Vss	Vcc1_5_A	Vcc1_5_A	VOID	VOID	VOID	Vcc1_5_B	Vcc1_5_B	Vss	Vss	Vss	PETp[3]	PETn[3]	L
Vss	Vss	Vcc1_5_A	VOID	VOID	VOID	Vcc1_5_B	Vcc1_5_B	Vss	PERp[3]	PERn[3]	Vss	Vss	M
Vss	Vss	Vss	VOID	VOID	VOID	Vcc1_5_B	Vcc1_5_B	Vcc1_5_B	Vcc1_5_B	Vcc1_5_B	PETp[4]	PETn[4]	N
Vss	Vss	Vcc1_5_A	VOID	VOID	VOID	Vcc1_5_B	Vss	PERp[4]	PERn[4]	Vcc1_5_B	Vcc1_5_B	Vcc1_5_B	P
Vss	Vss	Vss	VOID	VOID	VOID	Vcc1_5_B	Vcc1_5_B	Vss	Vss	Vss	DMI[0]TXP	DMI[0]TXN	R
Vss	Vss	Vcc1_5_A	VOID	VOID	VOID	Vcc1_5_B	Vcc1_5_B	Vss	DMI[0]RXP	DMI[0]RXN	Vss	Vss	T
Vss	Vcc1_5_A	Vcc1_5_A	VOID	VOID	VOID	Vcc1_5_B	Vcc1_5_B	Vss	Vss	Vss	DMI[1]TXP	DMI[1]TXN	U
VOID	VOID	VOID	VOID	VOID	VOID	Vcc1_5_B	Vcc1_5_B	Vss	DMI[1]RXP	DMI[1]RXN	Vss	Vss	V
VOID	VOID	VOID	VOID	VOID	VOID	Vcc1_5_B	Vcc1_5_B	Vss	Vss	Vss	DMI[2]TXP	DMI[2]TXN	W
VOID	VOID	VOID	VOID	VOID	VOID	Vcc1_5_B	Vcc1_5_B	Vss	DMI[2]RXP	DMI[2]RXN	Vss	Vss	Y
Vcc3_3	Vss	Vcc3_3	V5REF	Vcc1_5_A	Vcc1_5_A	Vcc1_5_A	Vcc1_5_B	Vcc1_5_B	Vcc1_5_B	Vcc1_5_B	DMI[3]TXP	DMI[3]TXN	AA
DDACK#	IDEIRQ	DA[1]	Vcc2_5	Vss	SERIRQ	GPO[19]	V_CPU_IO	DMI[3]RXP	DMI[3]RXN	Vcc1_5_B	Vcc1_5_B	Vcc1_5_B	AB
Vcc3_3	DA[0]	DA[2]	GPIO[34]	SATALED#	THRm#	STP_PC[1]#/GPO[18]†	Vss	Vss	Vss	DML_CLKP	Vss	VccDMIPLL	AC
Vss	DCS1#	Vcc3_3	Vss	BMBUSY#†/GPI[6]†	GPO[21]	GPO[23]	STP_CPU#†/GPO[20]†	RCIN#	Vss	DML_CLKN	V_CPU_IO	DPSP[1]#/TP[2]†	AD
DD[13]	DIOR#	DCS3#	SATA[1]GP†/GPI[29]	GP[7]	DPRSLPVR†/TP[1]†	Vss	INIT3_3V#	THRMTrip#	DPRSTP#†/TP[4]†	Vss	STPCLK#	CPUSLP#	AE
DD[1]	IORDY	SATA[0]GP/GPI[26]	SATA[2]GP/GPI[30]	CLKRUN#†/GPIO[32]†	GPIO[33]	VRMPWRGD	A20GATE	A20M#	FERR#	NMI	Vss	INIT#	AF
DD[14]	Vcc3_3	Vss	SATA[3]GP†/GPI[31]	Vcc3_3	Vss	MCH_SYNC#	Vss	V_CPU_IO	INTR	CPUPWRGD/GPO[49]	IGNNE#	SMI#	AG
15	16	17	18	19	20	21	22	23	24	25	26	27	

**Table 21-1. Intel® ICH6
Ballout by Signal Name**

Signal Name	Ball #
A20GATE	AF22
A20M#	AF23
ACZ_BIT_CLK	C10
ACZ_RST#	A10
ACZ_SDIN[0]	F11
ACZ_SDIN[1]	F10
ACZ_SDIN[2]	B10
ACZ_SDOOUT	C9
ACZ_SYNC	B9
AD[0]	E2
AD[1]	E5
AD[2]	C2
AD[3]	F5
AD[4]	F3
AD[5]	E9
AD[6]	F2
AD[7]	D6
AD[8]	E6
AD[9]	D3
AD[10]	A2
AD[11]	D2
AD[12]	D5
AD[13]	H3
AD[14]	B4
AD[15]	J5
AD[16]	K2
AD[17]	K5
AD[18]	D4
AD[19]	L6
AD[20]	G3
AD[21]	H4
AD[22]	H2
AD[23]	H5
AD[24]	B3
AD[25]	M6
AD[26]	B2
AD[27]	K6
AD[28]	K3
AD[29]	A5
AD[30]	L1

**Table 21-1. Intel® ICH6
Ballout by Signal Name**

Signal Name	Ball #
AD[31]	K4
BATLOW# [†] /TP[0] [‡]	V2
BMBUSY# [†] /GPI[6] [‡]	AD19
C/BE[0]#	J6
C/BE[1]#	H6
C/BE[2]#	G4
C/BE[3]#	G2
CLK14	E10
CLK48	A27
CLKRUN# [†] /GPIO[32] [‡]	AF19
CPUPWRGD/ GPO[49]	AG25
CPUSLP#	AE27
DA[0]	AC16
DA[1]	AB17
DA[2]	AC17
DCS1#	AD16
DCS3#	AE17
DD[0]	AD14
DD[1]	AF15
DD[2]	AF14
DD[3]	AD12
DD[4]	AE14
DD[5]	AC11
DD[6]	AD11
DD[7]	AB11
DD[8]	AE13
DD[9]	AF13
DD[10]	AB12
DD[11]	AB13
DD[12]	AC13
DD[13]	AE15
DD[14]	AG15
DD[15]	AD13
DDACK#	AB15
DDREQ	AB14
DEVSEL#	C3
DIOR#	AE16
DIOW#	AC14
DMI[0]RXN	T25
DMI[0]RXP	T24

**Table 21-1. Intel® ICH6
Ballout by Signal Name**

Signal Name	Ball #
DMI[0]TXN	R27
DMI[0]TXP	R26
DMI[1]RXN	V25
DMI[1]RXP	V24
DMI[1]TXN	U27
DMI[1]TXP	U26
DMI[2]RXN	Y25
DMI[2]RXP	Y24
DMI[2]TXN	W27
DMI[2]TXP	W26
DMI[3]RXN	AB24
DMI[3]RXP	AB23
DMI[3]TXN	AA27
DMI[3]TXP	AA26
DMI_CLKN	AD25
DMI_CLKP	AC25
DMI_IRCOMP	F23
DMI_ZCOMP	F24
DPSTLP# [†] /TP[2] [‡]	AD27
DPRSLPVR [†] /TP[1] [‡]	AE20
DPRSTP# [†] /TP[4] [‡]	AE24
EE_CS	D12
EE_DIN	F13
EE_DOUT	D11
EE_SHCLK	B12
FERR#	AF24
FRAME#	J3
GNT[0]#	C1
GNT[1]#	B6
GNT[2]#	F1
GNT[3]#	C8
GNT[4]#/GPO[48]	E7
GNT[5]#/GPO[17]	F6
GNT[6]#/GPO[16]	D8
GPO[23]	AD21
GPI[7]	AE19
GPI[8]	R1
GPI[12]	M2
GPI[13]	R6
GPO[19]	AB21
GPO[21]	AD20

Table 21-1. Intel® ICH6 Ballout by Signal Name

Signal Name	Ball #
GPIO[24]	V3
GPIO[25]	P5
GPIO[27]	R3
GPIO[28]	T3
GPIO[33]	AF20
GPIO[34]	AC18
IDEIRQ	AB16
IGNNE#	AG26
INIT#	AF27
INIT3_3V#	AE22
INTR	AG24
INTRUDER#	AA3
INTVRMEN	AA5
IRDY	AF16
IRDY#	A3
LAD[0]/FWH[0]	P2
LAD[1]/FWH[1]	N3
LAD[2]/FWH[2]	N5
LAD[3]/FWH[3]	N4
LAN_CLK	F12
LAN_RST#	V5
LAN_RSTSYNC	B11
LAN_RXD[0]	E12
LAN_RXD[1]	E11
LAN_RXD[2]	C13
LAN_TXD[0]	C12
LAN_TXD[1]	C11
LAN_TXD[2]	E13
LDRQ[0]#	N6
LDRQ[1]#/GPI[41]	P4
LFRAME#/FWH[4]	P3
LINKALERT#	Y5
MCH_SYNC#	AG21
NMI	AF25
OC[0]#	C27
OC[1]#	B27
OC[2]#	B26
OC[3]#	C26
OC[4]#/GPI[9]	C23
OC[5]#/GPI[10]	D23
OC[6]#/GPI[14]	C25

Table 21-1. Intel® ICH6 Ballout by Signal Name

Signal Name	Ball #
OC[7]#/GPI[15]	C24
PAR	E1
PCICLK	G6
PCIRST#	R2
PERn[1]	H25
PERn[2]	K25
PERn[3]	M25
PERn[4]	P24
PERp[1]	H24
PERp[2]	K24
PERp[3]	M24
PERp[4]	P23
PERR#	E3
PETn[1]	G27
PETn[2]	J27
PETn[3]	L27
PETn[4]	N27
PETp[1]	G26
PETp[2]	J26
PETp[3]	L26
PETp[4]	N26
PIRQ[A]#	N2
PIRQ[B]#	L2
PIRQ[C]#	M1
PIRQ[D]#	L3
PIRQ[E]#/GPI[2]	D9
PIRQ[F]#/GPI[3]	C7
PIRQ[G]#/GPI[4]	C6
PIRQ[H]#/GPI[5]	M3
PLOCK#	C5
PLTRST#	R5
PME#	P6
PWRBTN#	U1
PWROK	AA1
RCIN#	AD23
REQ[0]#	L5
REQ[1]#	B5
REQ[2]#	M5
REQ[3]#	B8
REQ[4]#/GPI[40]	F7
REQ[5]#/GPI[1]	E8

Table 21-1. Intel® ICH6 Ballout by Signal Name

Signal Name	Ball #
REQ[6]#/GPI[0]	B7
RI#	T2
RSMRST#	Y3
RTCST#	AA2
RTCX1	Y1
RTCX2	Y2
SATA[0]GP/GPI[26]	AF17
SATA[0]RXN	AE3
SATA[0]RXP	AD3
SATA[0]TXN	AG2
SATA[0]TXP	AF2
SATA[1]GP [†] /GPI[29]	AE18
SATA[1]RXN [†] / RESERVED [†]	AC5
SATA[1]RXP [†] / RESERVED [†]	AD5
SATA[1]TXN [†] / RESERVED [†]	AF4
SATA[1]TXP [†] / RESERVED [†]	AG4
SATA[2]GP/GPI[30]	AF18
SATA[2]RXN	AD7
SATA[2]RXP	AC7
SATA[2]TXN	AF6
SATA[2]TXP	AG6
SATA[3]GP [†] /GPI[31]	AG18
SATA[3]RXN [†] / RESERVED [†]	AC9
SATA[3]RXP [†] / RESERVED [†]	AD9
SATA[3]TXN [†] / RESERVED [†]	AF8
SATA[3]TXP [†] / RESERVED [†]	AG8
SATA_CLKN	AC2
SATA_CLKP	AC1
SATALED#	AC19
SATARBIAS	AF11
SATARBIAS#	AG11
SERIRQ	AB20
SERR#	G5
SLP_S3#	T4
SLP_S4#	T5
SLP_S5#	T6

**Table 21-1. Intel® ICH6
Ballout by Signal Name**

Signal Name	Ball #
SMBALERT#/GPI[11]	W6
SMBCLK	Y4
SMBDATA	W5
SMI#	AG27
SMLINK[0]	W4
SMLINK[1]	U6
SPKR	F8
STOP#	J1
STP_CPU# [†] / GPO[20] [‡]	AD22
STP_PCI# [†] /GPO[18] [‡]	AC21
STPCLK#	AE26
SUS_STAT#/LPCPD#	W3
SUSCLK	V6
SYS_RESET#	U2
THRMTRIP#	AE23
THRM#	AC20
TP[3]	U3
TRDY#	J2
USBP[0]N	C21
USBP[0]P	D21
USBP[1]N	A20
USBP[1]P	B20
USBP[2]N	D19
USBP[2]P	C19
USBP[3]N	A18
USBP[3]P	B18
USBP[4]N	E17
USBP[4]P	D17
USBP[5]N	B16
USBP[5]P	A16
USBP[6]N	C15
USBP[6]P	D15
USBP[7]N	A14
USBP[7]P	B14
USBRBIAS	B22
USBRBIAS#	A22
V_CPU_IO	AB22
V_CPU_IO	AD26
V_CPU_IO	AG23
V5REF	A8

**Table 21-1. Intel® ICH6
Ballout by Signal Name**

Signal Name	Ball #
V5REF	AA18
V5REF_Sus	F21
Vcc1_5_A	D24
Vcc1_5_A	D25
Vcc1_5_A	D26
Vcc1_5_A	D27
Vcc1_5_A	E20
Vcc1_5_A	E21
Vcc1_5_A	E22
Vcc1_5_A	E23
Vcc1_5_A	E24
Vcc1_5_A	F9
Vcc1_5_A	F20
Vcc1_5_A	G8
Vcc1_5_A	G20
Vcc1_5_A	L11
Vcc1_5_A	L12
Vcc1_5_A	L14
Vcc1_5_A	L16
Vcc1_5_A	L17
Vcc1_5_A	M11
Vcc1_5_A	M17
Vcc1_5_A	P11
Vcc1_5_A	P17
Vcc1_5_A	T11
Vcc1_5_A	T17
Vcc1_5_A	U11
Vcc1_5_A	U12
Vcc1_5_A	U14
Vcc1_5_A	U16
Vcc1_5_A	U17
Vcc1_5_A	AA6
Vcc1_5_A	AA7
Vcc1_5_A	AA8
Vcc1_5_A	AA9
Vcc1_5_A	AA19
Vcc1_5_A	AA20
Vcc1_5_A	AA21
Vcc1_5_A	AB4
Vcc1_5_A	AB5
Vcc1_5_A	AB6

**Table 21-1. Intel® ICH6
Ballout by Signal Name**

Signal Name	Ball #
Vcc1_5_A	AB8
Vcc1_5_A	AC4
Vcc1_5_A	AC8
Vcc1_5_A	AD4
Vcc1_5_A	AD8
Vcc1_5_A	AE4
Vcc1_5_A	AE5
Vcc1_5_A	AE8
Vcc1_5_A	AE9
Vcc1_5_A	AF5
Vcc1_5_A	AF9
Vcc1_5_A	AG5
Vcc1_5_A	AG9
Vcc1_5_B	F25
Vcc1_5_B	F26
Vcc1_5_B	F27
Vcc1_5_B	G22
Vcc1_5_B	G23
Vcc1_5_B	G24
Vcc1_5_B	G25
Vcc1_5_B	H21
Vcc1_5_B	H22
Vcc1_5_B	J21
Vcc1_5_B	J22
Vcc1_5_B	K21
Vcc1_5_B	K22
Vcc1_5_B	L21
Vcc1_5_B	L22
Vcc1_5_B	M21
Vcc1_5_B	M22
Vcc1_5_B	N21
Vcc1_5_B	N22
Vcc1_5_B	N23
Vcc1_5_B	N24
Vcc1_5_B	N25
Vcc1_5_B	P21
Vcc1_5_B	P25
Vcc1_5_B	P26
Vcc1_5_B	P27
Vcc1_5_B	R21
Vcc1_5_B	R22

Table 21-1. Intel® ICH6 Ballout by Signal Name

Signal Name	Ball #
Vcc1_5_B	T21
Vcc1_5_B	T22
Vcc1_5_B	U21
Vcc1_5_B	U22
Vcc1_5_B	V21
Vcc1_5_B	V22
Vcc1_5_B	W21
Vcc1_5_B	W22
Vcc1_5_B	Y21
Vcc1_5_B	Y22
Vcc1_5_B	AA22
Vcc1_5_B	AA23
Vcc1_5_B	AA24
Vcc1_5_B	AA25
Vcc1_5_B	AB25
Vcc1_5_B	AB26
Vcc1_5_B	AB27
Vcc2_5	P7
Vcc2_5	AB18
Vcc3_3	A6
Vcc3_3	B1
Vcc3_3	E4
Vcc3_3	E26
Vcc3_3	H1
Vcc3_3	H7
Vcc3_3	J7
Vcc3_3	L4
Vcc3_3	L7
Vcc3_3	M7
Vcc3_3	P1
Vcc3_3	AA10
Vcc3_3	AA12
Vcc3_3	AA14
Vcc3_3	AA15
Vcc3_3	AA17
Vcc3_3	AC15
Vcc3_3	AD17
Vcc3_3	AG10
Vcc3_3	AG13
Vcc3_3	AG16
Vcc3_3	AG19

Table 21-1. Intel® ICH6 Ballout by Signal Name

Signal Name	Ball #
VccDMIPLL	AC27
VccLAN1_5 [†] / VccSus1_5 [‡]	G10
VccLAN1_5 [†] / VccSus1_5 [‡]	G11
VccLAN3_3 [†] / VccSus3_3 [‡]	A13
VccLAN3_3 [†] / VccSus3_3 [‡]	F14
VccLAN3_3 [†] / VccSus3_3 [‡]	G13
VccLAN3_3 [†] / VccSus3_3 [‡]	G14
VccRTC	AB3
VccSATAPLL	AE1
VccSus1_5	G19
VccSus1_5	R7
VccSus1_5	U7
VccSus3_3	A11
VccSus3_3	A17
VccSus3_3	A24
VccSus3_3	B17
VccSus3_3	C16
VccSus3_3	C17
VccSus3_3	D16
VccSus3_3	E16
VccSus3_3	F15
VccSus3_3	F16
VccSus3_3	F18
VccSus3_3	G15
VccSus3_3	G16
VccSus3_3	G17
VccSus3_3	G18
VccSus3_3	U4
VccSus3_3	V1
VccSus3_3	V7
VccSus3_3	W2
VccSus3_3	Y7
VccUSBPLL	A25
VRMPWRGD	AF21
Vss	A1
Vss	A4
Vss	A7

Table 21-1. Intel® ICH6 Ballout by Signal Name

Signal Name	Ball #
Vss	A9
Vss	A12
Vss	A15
Vss	A19
Vss	A21
Vss	A23
Vss	A26
Vss	B13
Vss	B15
Vss	B19
Vss	B21
Vss	B23
Vss	B24
Vss	B25
Vss	C4
Vss	C14
Vss	C18
Vss	C20
Vss	C22
Vss	D1
Vss	D7
Vss	D10
Vss	D13
Vss	D14
Vss	D18
Vss	D20
Vss	D22
Vss	E14
Vss	E15
Vss	E18
Vss	E19
Vss	E25
Vss	E27
Vss	F4
Vss	F17
Vss	F19
Vss	F22
Vss	G1
Vss	G7
Vss	G9
Vss	G12

**Table 21-1. Intel® ICH6
Ballout by Signal Name**

Signal Name	Ball #
Vss	G21
Vss	H23
Vss	H26
Vss	H27
Vss	J4
Vss	J23
Vss	J24
Vss	J25
Vss	K1
Vss	K7
Vss	K23
Vss	K26
Vss	K27
Vss	L13
Vss	L15
Vss	L23
Vss	L24
Vss	L25
Vss	M4
Vss	M12
Vss	M13
Vss	M14
Vss	M15
Vss	M16
Vss	M23
Vss	M26
Vss	M27
Vss	N1
Vss	N7
Vss	N11
Vss	N12
Vss	N13
Vss	N14
Vss	N15
Vss	N16
Vss	N17
Vss	P12
Vss	P13
Vss	P14
Vss	P15
Vss	P16

**Table 21-1. Intel® ICH6
Ballout by Signal Name**

Signal Name	Ball #
Vss	P22
Vss	R4
Vss	R11
Vss	R12
Vss	R13
Vss	R14
Vss	R15
Vss	R16
Vss	R17
Vss	R23
Vss	R24
Vss	R25
Vss	T1
Vss	T7
Vss	T12
Vss	T13
Vss	T14
Vss	T15
Vss	T16
Vss	T23
Vss	T26
Vss	T27
Vss	U13
Vss	U15
Vss	U23
Vss	U24
Vss	U25
Vss	V4
Vss	V23
Vss	V26
Vss	V27
Vss	W1
Vss	W7
Vss	W23
Vss	W24
Vss	W25
Vss	Y6
Vss	Y23
Vss	Y26
Vss	Y27
Vss	AA4

**Table 21-1. Intel® ICH6
Ballout by Signal Name**

Signal Name	Ball #
Vss	AA11
Vss	AA13
Vss	AA16
Vss	AB1
Vss	AB2
Vss	AB7
Vss	AB9
Vss	AB10
Vss	AB19
Vss	AC3
Vss	AC6
Vss	AC10
Vss	AC12
Vss	AC22
Vss	AC23
Vss	AC24
Vss	AC26
Vss	AD1
Vss	AD2
Vss	AD6
Vss	AD10
Vss	AD15
Vss	AD18
Vss	AD24
Vss	AE2
Vss	AE6
Vss	AE7
Vss	AE10
Vss	AE11
Vss	AE12
Vss	AE21
Vss	AE25
Vss	AF1
Vss	AF3
Vss	AF7
Vss	AF10
Vss	AF12
Vss	AF26
Vss	AG1
Vss	AG3
Vss	AG7



**Table 21-1. Intel® ICH6
Ballout by Signal Name**

Signal Name	Ball #
Vss	AG12
Vss	AG14
Vss	AG17
Vss	AG20
Vss	AG22
WAKE#	U5

§



22 Electrical Characteristics

This chapter contains the DC and AC characteristics for the ICH6. AC timing diagrams are included.

22.1 Thermal Specifications

Refer to the *Intel® I/O Controller Hub 6 (ICH6) Thermal Design Guidelines* document for ICH6 thermal information.

22.2 Absolute Maximum Ratings

Table 22-1. Intel® ICH6 Absolute Maximum Ratings

Parameter	Maximum Limits
Voltage on any 3.3 V Pin with respect to Ground	-0.5 to Vcc3_3 + 0.5 V
Voltage on any 5 V Tolerant Pin with respect to Ground (V5REF=5V)	-0.5 to V5REF + 0.5 V
1.5 V Supply Voltage with respect to VSS	-0.5 to 2.1 V
2.5 V Supply Voltage with respect to Vss	-0.5 to 3.1 V
3.3 V Supply Voltage with respect to VSS	-0.5 to 4.6 V
5.0 V Supply Voltage with respect to VSS	-0.5 to 5.5 V
V_CPU_IO Supply Voltage with respect to VSS	0.8 to 1.75 V

22.3 DC Characteristics

Table 22-2. DC Current Characteristics

Power Plane	Maximum Power Consumption					
Symbol	S0	S1	S3 _{HOT}	S3 _{COLD}	S4/S5	G3
Vcc1_5_A	1.9 A	1.3 A	0.4 A	N/A	N/A	N/A
Vcc1_5_B Core	630 mA	230 mA	50 mA	N/A	N/A	N/A
Vcc3_3	380 mA	60 mA	60 mA	N/A	N/A	N/A
VccSus3_3	70 mA	30 mA	50 mA	30 mA	40 mA	N/A
V5REF	150 μ A	150 μ A	150 μ A	N/A	N/A	N/A
V5REF_Sus	10 mA	10 mA	10 mA	10 mA	10 mA	N/A
VccRTC ¹	N/A	N/A	N/A	N/A	N/A	6 μ A

NOTE:

1. IccRTC data is taken with VccRTC at 3.0 V while the system is in G3 state at room temperature and only the G3 state for this power well is shown to provide an estimate of battery life.

Table 22-3. DC Current Characteristics (Mobile Only)

Power Plane	Maximum Power Consumption			
	S0	S3 _{COLD}	S4/S5	G3
Symbol				
V_CPU_IO	14 mA	Off	Off	Off
Vcc1_5_A	1.9 A	Off	Off	Off
Vcc1_5_A ^{1,2}	1.9 A	Off	Off	Off
Vcc1_5_B	630 mA	Off	Off	Off
Vcc2_5	3 mA	Off	Off	Off
Vcc3_3 ³	340 mA	Off	Off	Off
Vcc3_3 ⁴	340 mA	Off	Off	Off
VccLAN1_5	20 mA	10 mA	10 mA	Off
VccLAN3_3 ⁵	30 mA	10 mA	10 mA	Off
VccLAN3_3 ⁶	30 mA	10 mA	10 mA	Off
VccSus1_5	20 mA	20 mA	20 mA	Off
VccSus3_3 ⁵	40 mA	30 mA	30 mA	Off
VccSus3_3 ⁶	40 mA	30 mA	30 mA	Off
VccRTC ⁷	N/A	N/A	N/A	6 μ A
V5REF	1 mA	Off	Off	Off
V5REF_Sus	10 mA	< 10 mA	< 10 mA	Off

NOTES:

1. Negligible change when VccSus1_5 Internal VR is enabled. Internal VccSus1_5 VR is enabled through ICH6-M strap option. This internal VR is tied to the Core well in S0. It is only tied to the VccSus3_3 rail for sleep states.
2. Includes worst case leakage.
3. Vcc2_5 Internal VR enabled.
4. Vcc2_5 Internal VR disabled.
5. VccSus1_5 Internal VR enabled.
6. VccSus1_5 Internal VR disabled.
7. IccRTC data is taken with VccRTC at 3.0 V while the system is in G3 state at room temperature and only the G3 state for this power well is shown to provide an estimate of battery life.

Table 22-4. DC Characteristic Input Signal Association (Sheet 1 of 2)

Symbol	Associated Signals
V_{IH1}/V_{IL1} (5 V Tolerant)	PCI Signals: AD[31:0], C/BE[3:0]#, DEVSEL#, FRAME#, IRDY#, PAR, PERR#, PLOCK#, REQ[3:0]#, REQ[4]#/GPI[40], REQ[5]#/GPI[1], REQ[6]#/GPI[0], SERR#, STOP#, TRDY# Interrupt Signals: PIRQ[D:A]#, PIRQ[H:E]#/GPI[5:2] (open drain) Strap Signals: REQ:[4:1]# (Strap purposes only)
V_{IH2}/V_{IL2} (5 V Tolerant)	Interrupt Signals: IDEIRQ Strap Signals: SPKR, TP[1]/DPRSLPVR, SATALED# (Strap purposes only)
V_{IH3}/V_{IL3}	Clock Signals: CLK14, CLK48 Power Management Signals: MCH_SYNC#, THRM#, VRMPWRGD SATA Signals: Desktop: SATAGP[3:0]/GPI[31:29,26] Mobile: SATAGP[2,0]/GPI[30,26] GPIO Signals: Desktop: GPI[[13,12,8], GPIO[34,33] Mobile: GPI[31,29,13,12,8], GPIO[34,33]
V_{IH4}/V_{IL4}	Clock Signals: PCICLK LPC/Firmware Hub Signals: LAD[3:0]/FWH[3:0], LDRQ[0]#, LDRQ[1]#/GPI[41] Power Management Signals: Desktop: LAN_RST# Mobile: BMBUSY#, CLKRUN#, LAN_RST# GPIO Signals: Desktop: GPI[32,7,6] Mobile: GPI[7] PCI Signals: PME# Interrupt Signals: SERIRQ Processor Signals: A20GATE, RCIN# USB Signals: OC[3:0]#, OC[5:4]#/GPI[10:9], OC[7:6]#/GPI[15:14] Strap Signals: GNT[6]#/GPO[16], GNT[5]#/GPO[17] (Strap purposes only)
V_{IH5}/V_{IL5}	SMBus Signals: SMBCLK, SMBDATA System Management Signals: SMBALERT#/GPI[11], SMLINK[1:0]
V_{IL6}/V_{IH6}	LAN Signals: LAN_CLK, LAN_RXD[2:0] EEPROM Signals: EE_DIN Strap Signals: EE_CS, EE_DOUT (Strap purposes only)
V_{IL7}/V_{IH7}	Processor Signals: FERR#, THRMTRIP#
V_{IMIN8}/V_{IMAX8}	PCI Express* Data RX Signals: PER[p,n][4:1]
V_{IL9}/V_{IH9}	Real Time Clock Signals: RTCX1
V_{IMIN10}/V_{IMAX10}	SATA Signals: Desktop: SATA[3:0]RX[P,N] Mobile: SATA[2,0]RX[P,N]
V_{IL11}/V_{IH11}	AC '97/Intel High Definition Audio Signals: ACZ_SDIN[2:0] AC '97 Signals: ACZ_BIT_CLK Strap Signals: ACZ_SDOUT, ACZ_SYNC (Strap purposes only)
$V_{IL12}/V_{IH12}/V_{cross(abs)}$	Clock Signals: DMI_CLKN, DMI_CLKP, SATA_CLKN, SATA_CLKP

Table 22-4. DC Characteristic Input Signal Association (Sheet 2 of 2)

Symbol	Associated Signals
V_{IH13}/V_{IL13}	<p>Power Management Signals: Desktop: PWRBTN#, RI#, SYS_RESET#, WAKE# Mobile: BATLOW#, PWRBTN#, RI#, SYS_RESET#, WAKE#</p> <p>System Management Signal: LINKALERT#</p> <p>GPIO Signals: GPIO[28,27,25,24]</p> <p>Other Signals: TP[3]</p> <p>Strap Signals: LINKALERT#, GPIO[25], TP[3] (Strap purposes only)</p>
V_{IH14}/V_{IL14}	<p>Power Management Signals: PWROK, RSMRST#, RTCRST#</p> <p>System Management Signals: INTRUDER#</p> <p>Other Signals: INTVRMEN</p>
$V_{DI} / V_{CM} / V_{SE}$ (5 V Tolerant)	USB Signals: USBP[7:0][P,N] (Low-speed and Full-speed)
$V_{HSSQ} / V_{HSDSC} / V_{HSCM}$ (5 V Tolerant)	USB Signals: USBP[7:0][P,N] (in High-speed Mode)
$V_{+}/V_{-}/V_{HYS} / V_{THRAVG}/V_{RING}$ (5 V tolerant)	<p>IDE Signals: DD:[15:0], DDREQ, IORDY.</p> <p>For Ultra DMA Mode 4 and lower, these signals follow the DC Characteristic for V_{IH2}/V_{IL2}.</p>

Table 22-5. DC Input Characteristics (Sheet 1 of 2)

Symbol	Parameter	Min	Max	Unit	Notes
V_{IL1}	Input Low Voltage	-0.5	$0.3(V_{CC3_3})$	V	
V_{IH1}	Input High Voltage	$0.5(V_{CC3_3})$	$V_{5REF} + 0.5$	V	
V_{IL2}	Input Low Voltage	-0.5	0.8	V	
V_{IH2}	Input High Voltage	2.0	$V_{5REF} + 0.5$	V	
V_{IL3}	Input Low Voltage	-0.5	0.8	V	
V_{IH3}	Input High Voltage	2.0	$V_{CC3_3} + 0.5$	V	
V_{IL4}	Input Low Voltage	-0.5	$0.3(V_{CC3_3})$	V	
V_{IH4}	Input High Voltage	$0.5(V_{CC3_3})$	$V_{CC3_3} + 0.5$	V	
V_{IL5}	Input Low Voltage	-0.5	0.8	V	
V_{IH5}	Input High Voltage	2.1	$V_{CCSUS3_3} + 0.5$	V	
V_{IL6}	Input Low Voltage	-0.5	$0.3(V_{CC3_3})$	V	
V_{IH6}	Input High Voltage	$0.6(V_{CC3_3})$	$V_{CC3_3} + 0.5$	V	
V_{IL7}	Input Low Voltage	-0.5	$0.58(V_{CPU_IO})$	V	
V_{IH7}	Input High Voltage	$0.73(V_{CPU_IO})$	$V_{CPU_IO} + 0.5$	V	
V_{IMIN8}	Minimum Input Voltage	175		mVdiff p-p	Note 1
V_{IMAX8}	Maximum Input Voltage		1200	mVdiff p-p	Note 1
V_{IL9}	Input Low Voltage	-0.5	0.10	V	
V_{IH9}	Input High Voltage	0.40	1.2	V	
V_{IMIN10}	Minimum Input Voltage	325		mVdiff p-p	Note 2
V_{IMAX10}	Maximum Input Voltage		600	mVdiff p-p	Note 2
V_{IL11}	Input Low Voltage	-0.5	$0.35(V_{CC3_3})$	V	
V_{IH11}	Input High Voltage	$0.65(V_{CC3_3})$	$V_{CC3_3} + 0.5$	V	
V_{IL12}	Input Low Voltage	-0.150	0.150	V	
V_{IH12}	Input High Voltage	0.660	0.850	V	
V_{IL13}	Input Low Voltage	-0.5	0.8	V	
V_{IH13}	Input High Voltage	2.0	$V_{CCSUS3_3} + 0.5$	V	
V_{IL14}	Input Low Voltage	-0.5	0.78	V	
V_{IH14}	Input High Voltage	2.0	$V_{CCRTC} + 0.5$	V	Note 3
$V_{cross(abs)}$	Absolute Crossing Point	0.250	0.550	V	
V_+	Low to high input threshold	1.5	2.0	V	Note 4
V_-	High to low input threshold	1.0	1.5	V	Note 4

Table 22-5. DC Input Characteristics (Sheet 2 of 2)

Symbol	Parameter	Min	Max	Unit	Notes
V_{HYS}	Difference between input thresholds: (V+current value) – (V– current value)	320		mV	Note 4
V_{THRAVG}	Average of thresholds: ((V+current value) + (V– current value))/2	1.3	1.7	V	Note 4
V_{RING}	AC Voltage at recipient connector	–1	6	V	Note 4, 5
V_{DI}	Differential Input Sensitivity	0.2		V	Note 6, 7
V_{CM}	Differential Common Mode Range	0.8	2.5	V	Note 8, 7
V_{SE}	Single-Ended Receiver Threshold	0.8	2.0	V	Note 7
V_{HSSQ}	HS Squelch Detection Threshold	100	150	mV	Note 7
V_{HSDSC}	HS Disconnect Detection Threshold	525	625	mV	Note 7
V_{HSCM}	HS Data Signaling Common Mode Voltage Range	–50	500	mV	Note 7
V_{HSSQ}	HS Squelch detection threshold	100	150	mV	Note 7
V_{HSDSC}	HS disconnect detection threshold	525	625	mV	Note 7
V_{HSCM}	HS data signaling common mode voltage range	–50	500	mV	Note 7

NOTES:

1. PCI Express mVdiff p-p = |PETp[x] – PETn[x]|
2. SATA Vdiff, tx ($V_{IMAX/MIN10}$ is measured at the SATA connector on the transmit side (generally, the motherboard connector), where SATA mVdiff p-p = |SATA[x]TXP/RXP – SATA[x]TXN/RXN|
3. VccRTC is the voltage applied to the VccRTC well of the ICH6. When the system is in a G3 state, this is generally supplied by the coin cell battery, but for S5 and greater, this is generally VccSus3_3.
4. Applies to Ultra DMA Modes greater than Ultra DMA Mode 4
5. This is an AC Characteristic that represents transient values for these signals
6. $V_{DI} = |USBPx[P] – USBPx[N]|$
7. Applies to High-speed USB 2.0
8. Includes V_{DI} range

Table 22-6. DC Characteristic Output Signal Association

Symbol	Associated Signals
V_{OH1}/V_{OL1}	IDE Signals: DA[2:0], DCS[3,1]#, DDACK#, DD[15:0], DIOR#, DIOW#
V_{OH2}/V_{OL2}	Processor Signals: Desktop: A20M#, CPUSLP#, IGNNE#, INIT#, INTR, NMI, SMI#, STPCLK# Mobile: A20M#, CPUSLP#, DPUSLP#, DPRSTP#, IGNNE#, INIT#, INTR, NMI, SMI#, STPCLK#
V_{OH3}/V_{OL3}	PCI Signals: AD[31:0], C/BE[3:0]#, DEVSEL#, FRAME#, IRDY#, PAR, PERR#, PLOCK#, SERR#, STOP#, TRDY# AC '97/Intel High Definition Audio Signals: ACZ_RST#, ACZ_SDOOUT, ACZ_SYNC Intel High Definition Audio Signals: ACZ_BIT_CLK
V_{OL4}/V_{OH4}	SMBus Signals: SMBCLK ¹ , SMBDATA ¹ System Management Signals: SMLINK[1:0] ¹
V_{OL5}/V_{OH5}	Power Management Signals: Desktop: PLTRST#, SLP_S3#, SLP_S4#, SLP_S5#, SUSCLK#, SUS_STAT Mobile: DPRSLPVR, PLTRST#, SLP_S3#, SLP_S4#, SLP_S5#, STP_CPU#, STP_PCI#, SUSCLK#, SUS_STAT GPIO Signals: Desktop: GPO[24,23,20:18], GPIO[34,33,28,27,25] Mobile: GPO[24,23,19], GPIO[34,33,28,27,25] Other Signals: SPKR SATA Signal: SATALED# Processor Interface Signal: INIT3_3V# LAN Signals: LAN_RSTSYNC, LAN_TXD[2:0] EEPROM Signals: EE_CS, EE_DOUT, EE_SHCLK
V_{OL6}/V_{OH6}	USB Signals: USBP[7:0][P,N] in Low-speed and Full-speed Modes
V_{OMIN7}/V_{OMAX7}	PCI Express* Data TX Signals: PET[p,n][4:1]
V_{OMIN8}/V_{OMAX8}	SATA Signals: Desktop: SATA[3:0]TX[P,N] Mobile: SATA[2,0]TX[P,N]
V_{OL9}/V_{OH9}	LPC/Firmware Hub Signals: LAD[3:0]/FWH[3:0], LFRAME#/FWH[4] PCI Signals: Desktop: PCIRST#, GNT[3:0]#, GNT[4]/GPO[48], GNT[5]/GPO[17], GNT[6]/GPO[16] Mobile: PCIRST#, CLKRUN#, GNT[3:0]#, GNT[4]/GPO[48], GNT[5]/GPO[17], GNT[6]/GPO[16] GPIO Signals: Desktop: GPO[21], GPIO[32] Mobile: GPO[21] Interrupt Signals: SERIRQ
V_{OL10}/V_{OH10}	Processor Signal: CPUPWRGD/GPO[49] ¹
V_{HSOI} V_{HSOH} V_{HSOL} V_{CHIRPJ} V_{CHIRPK}	USB Signals: USBP[7:0][P:N] in High-speed Mode

NOTE:

1. These signals are open drain.

Table 22-7. DC Output Characteristics

Symbol	Parameter	Min	Max	Unit	I _{OL} /I _{OH}	Notes
V _{OL1}	Output Low Voltage	–	0.51	V	TBD	
V _{OH1}	Output High Voltage	V _{CC3_3} – 0.51	–	V	TBD	
V _{OL2}	Output Low Voltage	–	0.255	V	3 mA	
V _{OH2}	Output High Voltage	V _{CPU_IO} - 0.3	–	V	-0.3 mA	Note 1
V _{OL3}	Output Low Voltage	–	0.1(V _{CC3_3})	V	6 mA	
V _{OH3}	Output High Voltage	0.9(V _{CC3_3})	–	V	-0.5 mA	
V _{OL4}	Output Low Voltage	–	0.4	V	4 mA	
V _{OH4}	Output High Voltage	V _{CCSus3_3} - 0.5	–	V	-2 mA	Note 1
V _{OL5}	Output Low Voltage	–	0.4	V	6 mA	Note 2
V _{OH5}	Output High Voltage	V _{CC3_3} - 0.5	–	V	-2 mA	Note 1
V _{OL6}	Output Low Voltage	–	0.4	V	5 mA	
V _{OH6}	Output High Voltage	V _{CC3_3} – 0.5	–	V	-2 mA	
V _{OMIN7}	Minimum Output Voltage	800	–	mV _{diff} p-p		Note 3
V _{OMAX7}	Maximum Output Voltage	–	1200	mV _{diff} p-p		Note 3
V _{OMIN8}	Minimum Output Voltage	400	–	mV _{diff} p-p		Note 4
V _{OMAX8}	Maximum Output Voltage	–	600	mV _{diff} p-p		Note 4
V _{OL9}	Output Low Voltage	–	0.1(V _{CC3_3})	V	1.5 mA	
V _{OH9}	Output High Voltage	0.9(V _{CC3_3})	–	V	-0.5 mA	
V _{OL10}	Output Low Voltage	–	0.125	V	3 mA	Note 5
V _{OH10}	Output High Voltage	–	–			Note 1
V _{HSOI}	HS Idle Level	–10.0	10.0	mV		
V _{HSOH}	HS Data Signaling High	360	440	mV		
V _{HSOL}	HS Data Signaling Low	–10.0	10.0	mV		
V _{CHIRPJ}	Chirp J Level	700	1100	mV		
V _{CHIRPK}	Chirp K Level	–900	–500	mV		

NOTES:

1. The CPUPWRGD, SERR#, PIRQ[H:A], SMBDATA, SMBCLK, LINKALERT#, and SMLINK[1:0] signal has an open drain driver and SATALED# has an open collector driver, and the V_{OH} specification does not apply. This signal must have external pull up resistor.
2. For INIT3_3V only, for low current devices, the following low current specification applies: VOL5 Max is 0.15V at IOL5 of 2 mA.
3. PCI Express mV_{diff} p-p = |PETp[x] – PETn[x]|
4. SATA V_{diff}, tx (VOMAX/MIN8 is measured at the SATA connector on the transmit side (generally, the motherboard connector), where SATA mV_{diff} p-p = |SATA[x]TXP/RXP – SATA[x]TXN/RXN|
5. Maximum I_{OL} for CPUPWRGD is 12mA for short durations (<500mS per 1.5 s) and 9mA for long durations.

Table 22-8. Other DC Characteristics

Symbol	Parameter	Min	Max	Unit	Notes
V5REF	ICH6 Core Well Reference Voltage	4.75	5.25	V	
Vcc3_3	I/O Buffer Voltage	3.135	3.465	V	
Vcc1_5_A, Vcc1_5_B, VccUSBPLL, VccSATAPLL, VccDMIPLL	Internal Logic Voltage	1.425	1.575	V	
V_CPU_IO	Processor I/F	1.0	1.425	V	
V5REF_Sus	Suspend Well Reference Voltage	4.75	5.25	V	
VccSus3_3	Suspend Well I/O Buffer Voltage	3.135	3.465	V	
Vcc2_5	Internal Logic Voltage	2.375	2.625	V	
VccSus1_5	Suspend Well Logic Voltage	1.425	1.575	V	
VccLAN3_3 (Mobile Only)	LAN Controller I/O Buffer Voltage	3.135	3.465	V	
VccLAN1_5 (Mobile Only)	LAN Controller Logic Voltage	1.425	1.575	V	
VccRTC	Battery Voltage	2.0	3.6	V	
V _{DI}	Differential Input Sensitivity	0.2		V	{(USBPx+,USBPx-)}
V _{CM}	Differential Common Mode Range	0.8	2.5	V	Includes V _{DI}
V _{CRS}	Output Signal Crossover Voltage	1.3	2.0	V	
V _{SE}	Single Ended Rcvr Threshold	0.8	2.0	V	
I _{LI1}	ATA Input Leakage Current	-200	200	μA	(0 V < V _{IN} < 5V)
I _{LI2}	PCI_3V Hi-Z State Data Line Leakage	-10	10	μA	(0 V < V _{IN} < 3.3V)
I _{LI3}	PCI_5V Hi-Z State Data Line Leakage	-70	70	μA	Max V _{IN} = 2.7 V Min V _{IN} = 0.5 V
I _{LI4}	Input Leakage Current – Clock signals	-100	+100	μA	Note 1
C _{IN}	Input Capacitance – All Other	–	12	pF	F _C = 1 MHz
C _{OUT}	Output Capacitance	–	12	pF	F _C = 1 MHz
C _{I/O}	I/O Capacitance	–	12	pF	F _C = 1 MHz
		Typical Value			
C _L	XTAL1	6		pF	
C _L	XTAL2	6		pF	

NOTES:

1. Includes CLK14, CLK48, LAN_CLK and PCICLK

22.4 AC Characteristics

Table 22-9. Clock Timings (Sheet 1 of 2)

Sym	Parameter	Min	Max	Unit	Figure	Notes
PCI Clock (PCICLK)						
t1	Period	30	33.3	ns	22-1	
t2	High Time	12		ns	22-1	
t3	Low Time	12		ns	22-1	
t4	Rise Time	–	3	ns	22-1	
t5	Fall Time	–	3	ns	22-1	
14 MHz Clock (CLK14)						
t6	Period	67	70	ns	22-1	
t7	High Time	20	–	ns	22-1	
t8	Low Time	20	–	ns	22-1	
t41	Rising Edge Rate	1.0	4.0	V/ns		1
t42	Falling Edge Rate	1.0	4.0	V/ns		1
48 MHz Clock (CLK48)						
f _{clk48}	Operating Frequency	48.000	–	MHz		2
t9	Frequency Tolerance	–	100	ppm		
t10	High Time	7	–	ns	22-1	
t11	Low Time	7	–	ns	22-1	
t12	Rise Time	–	1.2	ns	22-1	
t13	Fall Time	–	1.2	ns	22-1	
SMBus Clock (SMBCLK)						
f _{smb}	Operating Frequency	10	16	KHz		
t18	High time	4.0	50	us	22-16	3
t19	Low time	4.7	–	us	22-16	
t20	Rise time	–	1000	ns	22-16	
t21	Fall time	–	300	ns	22-16	

Table 22-9. Clock Timings (Sheet 2 of 2)

Sym	Parameter	Min	Max	Unit	Figure	Notes
AC '97 Clock (ACZ_BIT_CLK - AC '97 mode)						
f _{ac97}	Operating Frequency	12.288		MHz		
t ₂₆	Input Jitter (refer to Clock Chip Specification)	–	2	ns		4
t ₂₇	High time	36	45	ns	22-1	
t ₂₈	Low time	36	45	ns	22-1	
t ₂₉	Rise time	2.0	6.0	ns	22-1	5
t ₃₀	Fall time	2.0	6.0	ns	22-1	5
ACZ_BIT_CLK (Intel High Definition Audio Mode)						
f _{HDA}	Operating Frequency	24.0		MHz		
	Frequency Tolerance	–	100	ppm		
t _{26a}	Input Jitter (refer to Clock Chip Specification)	–	300	ppm		
t _{27a}	High Time (Measured at 0.75V _{cc})	18.75	22.91	ns	22-1	
t _{28a}	Low Time (Measured at 0.35V _{cc})	18.75	22.91	ns	22-1	
SATA Clock (SATA_CLKP, SATA_CLKN) / DMI Clock (DMI_CLKP, DMI_CLKN)						
t ₃₆	Period	9.997	10.003	ns		
t ₃₇	Rise time	175	700	ps		
t ₃₈	Fall time	175	700	ps		
Suspend Clock (SUSCLK)						
f _{susclk}	Operating Frequency	32		kHz		6
t ₃₉	High Time	10	–	us		6
t ₄₀	Low Time	10	–	us		6

NOTES:

1. CLK14 edge rates in a system as measured from 0.8 V to 2.0 V.
2. The CLK48 expects a 40/60% duty cycle.
3. The maximum high time (t₁₈ Max) provide a simple guaranteed method for devices to detect bus idle conditions.
4. The ICh6 can tolerate a maximum of 2 ns of jitter from the input BITCLK. Note that clock jitter may impact system timing. If routing guidelines for AC '97 were not followed as published in the Platform Design Guides, system designers should ensure the input clock jitter does not negatively impact the system timing.
5. BITCLK Rise and Fall times are measured from 10%V_{DD} and 90%V_{DD}.
6. SUSCLK duty cycle can range from 30% minimum to 70% maximum.

Table 22-10. PCI Interface Timing

Sym	Parameter	Min	Max	Units	Figure	Notes
t40	AD[31:0] Valid Delay	2	11	ns	22-2	1
t41	AD[31:0] Setup Time to PCICLK Rising	7	–	ns	22-3	
t42	AD[31:0] Hold Time from PCICLK Rising	0	–	ns	22-3	
t43	C/BE[3:0]#, FRAME#, TRDY#, IRDY#, STOP#, PAR, PERR#, PLOCK#, DEVSEL# Valid Delay from PCICLK Rising	2	11	ns	22-2	1
t44	C/BE[3:0]#, FRAME#, TRDY#, IRDY#, STOP#, PAR, PERR#, PLOCK#, IDSEL, DEVSEL# Output Enable Delay from PCICLK Rising	2	–	ns	22-6	
t45	C/BE[3:0]#, FRAME#, TRDY#, IRDY#, STOP#, PERR#, PLOCK#, DEVSEL#, GNT[A:B]# Float Delay from PCICLK Rising	2	28	ns	22-4	
t46	C/BE[3:0]#, FRAME#, TRDY#, IRDY#, STOP#, SERR#, PERR#, DEVSEL#, Setup Time to PCICLK Rising	7	–	ns	22-3	
t47	C/BE[3:0]#, FRAME#, TRDY#, IRDY#, STOP#, SERR#, PERR#, DEVSEL#, REQ[A:B]# Hold Time from PCLKIN Rising	0	–	ns	22-3	
t48	PCIRST# Low Pulse Width	1	–	ms	22-5	
t49	GNT[6:0]# Valid Delay from PCICLK Rising	2	12	ns		
t50	REQ[6:0]# Setup Time to PCICLK Rising	12	–	ns		

NOTES:

1. Refer to note 3 of table 4-4 in Section 4.2.2.2 and note 2 of table 4-6 in Section 4.2.3.2 of the *PCI Local Bus Specification, Revision 2.3* for measurement details.

Table 22-11. IDE PIO Mode Timings

Sym	Parameter	Mode 0 (nS)	Mode 1 (nS)	Mode 2 (nS)	Mode 3 (nS)	Mode 4 (nS)	Figure
t60	Cycle Time (min)	600	383	240	180	120	22-7
t61	Addr setup to DIOW#/DIOR# (min)	70	50	30	30	25	22-7
t62	DIRW#/DIOR# (min)	165	125	100	80	70	22-7
t62i	DIOW#/DIOR# recovery time (min)	–	–	–	70	25	22-7
t63	DIOW# data setup (min)	60	45	30	30	20	22-7
t64	DIOW# data hold (min)	30	20	15	10	10	22-7
t65	DIOR# data setup (min)	50	35	20	20	20	22-7
t66	DIOR# data hold (min)	5	5	5	5	5	22-7
t66z	DIOR# data tri-state (max)	30	30	30	30	30	22-7
t69	DIOW#/DIOR# to address valid hold (min)	20	15	10	10	10	22-7
t60rd	Read data Valid to IORDY active (min)	0	0	0	0	0	22-7
t60a	IORDY Setup	35	35	35	35	35	22-7
t60b	IORDY Pulse Width (max)	1250	1250	1250	1250	1250	22-7
t60c	IORDY assertion to release (max)	5	5	5	5	5	22-7

Table 22-12. IDE Multiword DMA Timings

Sym	Parameter	Mode 0 (nS)	Mode 1 (nS)	Mode 2 (nS)	Figure
t70	Cycle Time (min)	480	150	120	22-8
t70d	DIOR#/DIOw# (min)	215	80	70	22-8
t70e	DIOR# Data access (max)	150	60	50	22-8
t70f	DIOR# Data hold (min)	5	5	5	22-8
t70g	DIOR#/DIOw# Data setup (min)	100	30	20	22-8
t70h	DIOw# Data hold (min)	20	15	10	22-8
t70i	DDACK# to DIOR#/DIOw# setup (min)	0	0	0	22-8
t70j	DIOR#/DIOw# to DDACK# hold (min)	20	5	5	22-8
t70kr	DIOR# negated pulse width (min)	50	50	25	22-8
t70kw	DIOw# negated pulse width (min)	215	50	25	22-8
t70lr	DIOR# to DDREQ delay (max)	120	40	35	22-8
t70lw	DIOw# to DDREQ delay (max)	40	40	35	22-8
t70m	DCS1#/DCS3# valid to DIOR#/DIOw# (min)	50	30	25	22-8
t70n	DCS1#/DCS3# hold (min)	15	10	10	22-8
t70z	DDACK# to tri-state (max)	20	25	25	22-8

Table 22-13. Ultra ATA Timing (Mode 0, Mode 1, Mode 2) (Sheet 1 of 2)

Sym	Parameter ¹	Mode 0 (ns)		Mode 1 (ns)		Mode 2 (ns)		Measuring Location	Figure
		Min	Max	Min	Max	Min	Max		
t80	Sustained Cycle Time (T2cyctyp)	240		160		120		Sender Connector	
t81	Cycle Time (Tcyc)	112	–	73	–	54	–	End Recipient Connector	22-10
t82	Two Cycle Time (T2cyc)	230	–	153	–	115	–	Sender Connector	22-10
t83a	Data Setup Time (Tds)	15	–	10	–	7	–	Recipient Connector	22-10
t83b	Recipient IC data setup time (from data valid until STROBE edge) (see Note 2) (Tdsic)	14.7	–	9.7	–	6.8	–	ICH6 ball	
t84a	Data Hold Time (Tdh)	5	–	5	–	5	–	Recipient Connector	22-10
t84b	Recipient IC data hold time (from STROBE edge until data may become invalid) (see Note 2) (Tdhic)	4.8	–	4.8	–	4.8	–	ICH6 ball	
t85a	Data Valid Setup Time (Tdvs)	70	–	48	–	31	–	Sender Connector	22-10
t85b	Sender IC data valid setup time (from data valid until STROBE edge) (see Note 2) (Tdvsic)	72.9	–	50.9	–	33.9	–	ICH6 ball	
t86a	Data Valid Hold Time (Tdvh)	6.2	–	6.2	–	6.2	–	Sender Connector	22-10
t86b	Sender IC data valid hold time (from STROBE edge until data may become invalid) (see Note 2) (Tdvhic)	9	–	9	–	9	–	ICH6 ball	
t87	Limited Interlock Time (Tli)	0	150	0	150	0	150	Note 2	22-12
t88	Interlock Time w/ Minimum (Tmli)	20	–	20	–	20	–	Host Connector	22-12
t89	Envelope Time (Tenv)	20	70	20	70	20	70	Host Connector	22-9
t90	Ready to Pause Time (Trp)	160	–	125	–	100	–	Recipient Connector	22-11
t91	DMACK setup/hold Time (Tack)	20	–	20	–	20	–	Host Connector	22-9, 22-12
t92a	CRC Word Setup Time at Host (Tcvs)	70	–	48	–	31	–	Host Connector	
t92b	CRC word valid hold time at sender (from DMACK# negation until CRC may become invalid) (see Note 2) (Tcvh)	6.2	–	6.2	–	6.2	–	Host Connector	

Table 22-13. Ultra ATA Timing (Mode 0, Mode 1, Mode 2) (Sheet 2 of 2)

Sym	Parameter ¹	Mode 0 (ns)		Mode 1 (ns)		Mode 2 (ns)		Measuring Location	Figure
		Min	Max	Min	Max	Min	Max		
t93	STROBE output released-to-driving to the first transition of critical timing (Tzfs)	0	–	0	–	0	–	Device Connector	22-12
t94	Data Output Released-to-Driving Until the First Transition of Critical Timing (Tdzfs)	70	–	48	–	31	–	Sender Connector	22-9
t95	Unlimited Interlock Time (Tui)	0	–	0	–	0	–	Host Connector	22-9
t96a	Maximum time allowed for output drivers to release (from asserted or negated) (Taz)	–	10	–	10	–	10	Note 2	
t96b	Minimum time for drivers to assert or negate (from released) (Tzad)	0	–	0	–	0	–	Device Connector	
t97	Ready-to-final-STROBE time (no STROBE edges shall be sent this long after negation of DMARDY#) (Trfs)	–	75	–	70	–	60	Sender Connector	22-9
t98a	Maximum time before releasing IORDY (Tiordyz)	–	20	–	20	–	20	Device Connector	
t98b	Minimum time before driving IORDY (see Note 2) (Tziordy)	0	–	0	–	0	–	Device Connector	
t99	Time from STROBE edge to negation of DMARQ or assertion of STOP (when sender terminates a burst) (Tss)	50	–	50	–	50	–	Sender Connector	22-11

NOTES:

1. The specification symbols in parentheses correspond to the AT Attachment – 6 with Packet Interface (ATA/ATAPI – 6) specification name.
2. See the AT Attachment – 6 with Packet Interface (ATA/ATAPI – 6) specification for further details on measuring these timing parameters.

Table 22-14. Ultra ATA Timing (Mode 3, Mode 4, Mode 5) (Sheet 1 of 2)

Sym	Parameter ¹	Mode 3 (ns)		Mode 4 (ns)		Mode 5 (ns)		Measuring Location	Figure
		Min	Max	Min	Max	Min	Max		
t80	Sustained Cycle Time (T2cyc _{typ})	90		60		40		Sender Connector	
t81	Cycle Time (T _{cyc})	39	–	25	–	16.8	–	End Recipient Connector	22-10
t82	Two Cycle Time (T2cyc)	86	–	57	–	38	–	Sender Connector	22-10
t83	Data Setup Time (T _{ds})	7	–	5	–	4.0	–	Recipient Connector	22-10
t83b	Recipient IC data setup time (from data valid until STROBE edge) (see Note 2) (T _{dsic})	6.8	–	4.8	–	2.3	–	ICH6 Balls	
t84	Data Hold Time (T _{dh})	5	–	5	–	4.6	–	Recipient Connector	22-10
t84b	Recipient IC data hold time (from STROBE edge until data may become invalid) (see Note 2) (T _{dhic})	4.8	–	4.8	–	2.8	–	ICH6 Balls	
t85	Data Valid Setup Time (T _{dvs})	20	–	6.7	–	4.8	–	Sender Connector	22-9 22-10
t85b	Sender IC data valid setup time (from data valid until STROBE edge) (see Note 2) (T _{dvsic})	22.6	–	9.5	–	6.0	–	ICH6 Balls	
t86	Data Valid Hold Time (T _{dvh})	6.2	–	6.2	–	4.8	–	Sender Connector	22-9 22-10
t86b	Sender IC data valid hold time (from STROBE edge until data may become invalid) (see Note 2) (T _{dvhic})	9.0	–	9.0	–	6.0	–	ICH6 Balls	
t87	Limited Interlock Time (T _{li})	0	100	0	100	0	75	Note 2	22-12
t88	Interlock Time w/ Minimum (T _{mli})	20	–	20	–	20	–	Host Connector	22-12
t89	Envelope Time (T _{env})	20	55	20	55	20	50	Host Connector	22-10
t90	Ready to Pause Time (T _{rp})	100	–	100	–	85	–	Recipient Connector	22-11
t91	DMACK setup/hold Time (T _{ack})	20	–	20	–	20	–	Host Connector	22-12
t92a	CRC Word Setup Time at Host (T _{cv_s})	20	–	6.7	–	10	–	Host Connector	
t92b	CRC Word Hold Time at Sender CRC word valid hold time at sender (from DMACK# negation until CRC may become invalid) (see Note 2) (T _{cv_h})	6.2	–	6.2	–	10.0	–	Host Connector	

Table 22-14. Ultra ATA Timing (Mode 3, Mode 4, Mode 5) (Sheet 2 of 2)

Sym	Parameter ¹	Mode 3 (ns)		Mode 4 (ns)		Mode 5 (ns)		Measuring Location	Figure
		Min	Max	Min	Max	Min	Max		
t93	STROBE output released-to-driving to the first transition of critical timing (Tzfs)	0	–	0	–	35	–	Device Connector	22-12
t94	Data Output Released-to-Driving Until the First Transition of Critical Timing (Tdzfs)	20.0	–	6.7	–	25	–	Sender Connector	
t95	Unlimited Interlock Time (Tui)	0	–	0	–	0	–	Host Connector	
t96a	Maximum time allowed for output drivers to release (from asserted or negated) (Taz)	–	10	–	10	–	10	Note 2	
t96b	Drivers to assert or negate (from released) (Tzad)	0	–	0	–	0	–	Device Connector	
t97	Ready-to-final-STROBE time (no STROBE edges shall be sent this long after negation of DMARDY#) (Trfs)	–	60	–	60	–	50	Sender Connector	
t98a	Maximum time before releasing IORDY (Tiordyz)	–	20	–	20	–	20	Device Connector	
t98b	Minimum time before driving IORDY (see Note 2) (Tziordy)	0	–	0	–	0	–	Device Connector	
t99	Time from STROBE edge to negation of DMARQ or assertion of STOP (when sender terminates a burst) (Tss)	50	–	50	–	50	–	Sender Connector	22-11

NOTES:

1. The specification symbols in parentheses correspond to the AT Attachment – 6 with Packet Interface (ATA/ATAPI – 6) specification name.
2. See the AT Attachment – 6 with Packet Interface (ATA/ATAPI – 6) specification for further details on measuring these timing parameters.

Table 22-15. Universal Serial Bus Timing

Sym	Parameter	Min	Max	Units	Fig	Notes
Full-speed Source¹						
t100	USBPx+, USBPx- Driver Rise Time	4	20	ns	22-13	2, C _L = 50 pF
t101	USBPx+, USBPx- Driver Fall Time	4	20	ns	22-13	2, C _L = 50 pF
t102	Source Differential Driver Jitter To Next Transition For Paired Transitions	-3.5 -4	3.5 4	ns ns	22-14	3, 4
t103	Source SE0 interval of EOP	160	175	ns	22-15	5
t104	Source Jitter for Differential Transition to SE0 Transition	-2	5	ns		6
t105	Receiver Data Jitter Tolerance To Next Transition For Paired Transitions	-18.5 -9	18.5 9	ns ns	22-14	4
t106	EOP Width: Must accept as EOP	82	-	ns	22-15	5
t107	Width of SE0 interval during differential transition	-	14	ns		
Low-speed Source⁷						
t108	USBPx+, USBPx – Driver Rise Time	75	300	ns	22-13	2, 8 C _L = 50 pF C _L = 350 pF
t109	USBPx+, USBPx – Driver Fall Time	75	300	ns	22-13	2, 8 C _L = 50 pF C _L = 350 pF
t110	Source Differential Driver Jitter To Next Transition For Paired Transitions	-25 -14	25 14	ns ns	22-14	3, 4
t111	Source SE0 interval of EOP	1.25	1.50	µs	22-15	5
t112	Source Jitter for Differential Transition to SE0 Transition	-40	100	ns		6
t113	Receiver Data Jitter Tolerance To Next Transition For Paired Transitions	-152 -200	152 200	ns ns	22-14	4
t114	EOP Width: Must accept as EOP	670	-	ns	22-15	5
t115	Width of SE0 interval during differential transition	-	210	ns		

NOTES:

1. Full-speed Data Rate has minimum of 11.97 Mb/s and maximum of 12.03 Mb/s.
2. Driver output resistance under steady state drive is specified at 28 ohms at minimum and 43 ohms at maximum.
3. Timing difference between the differential data signals.
4. Measured at crossover point of differential data signals.
5. Measured at 50% swing point of data signals.
6. Measured from last crossover point to 50% swing point of data line at leading edge of EOP.
7. Low-speed Data Rate has a minimum of 1.48 Mb/s and a maximum of 1.52 Mb/s.
8. Measured from 10% to 90% of the data signal.

Table 22-16. SATA Interface Timings

Sym	Parameter	Min	Max	Units	Figure	Notes
UI	Operating Data Period	666.43	670.12	ps		
	Rise Time	0.2	0.41	UI		1
	Fall Time	0.2	0.41	UI		2
	TX differential skew	–	20	ps		
	COMRESET	310.4	329.6	ns		3
	COMWAKE transmit spacing	103.5	109.9	ns		3
	OOB Operating Data period	646.67	686.67	ns		4

NOTES:

1. 20% – 80% at transmitter
2. 80% – 20% at transmitter
3. As measured from 100 mV differential crosspoints of last and first edges of burst.
4. Operating data period during Out-Of-Band burst transmissions.

Table 22-17. SMBus Timing

Sym	Parameter	Min	Max	Units	Fig	Notes
t130	Bus Tree Time Between Stop and Start Condition	4.7	–	μs	22-16	
t131	Hold Time after (repeated) Start Condition. After this period, the first clock is generated.	4.0	–	μs	22-16	
t132	Repeated Start Condition Setup Time	4.7	–	μs	22-16	
t133	Stop Condition Setup Time	4.0	–	μs	22-16	
t134	Data Hold Time	0	–	ns	22-16	1
t135	Data Setup Time	250	–	ns	22-16	
t136	Device Time Out	25	35	ms		2
t137	Cumulative Clock Low Extend Time (slave device)	–	25	ms	22-17	3
t138	Cumulative Clock Low Extend Time (master device)	–	10	ms	22-17	4

NOTE:

1. t134 has a minimum timing for I²C of 0 ns, while the minimum timing for SMBus is 300 ns.
2. A device will timeout when any clock low exceeds this value.
3. t137 is the cumulative time a slave device is allowed to extend the clock cycles in one message from the initial start to stop. If a slave device exceeds this time, it is expected to release both its clock and data lines and reset itself.
4. t138 is the cumulative time a master device is allowed to extend its clock cycles within each byte of a message as defined from start-to-ack, ack-to-ack or ack-to-stop.

Table 22-18. AC '97 / Intel® High Definition Audio Timing

Sym	Parameter	Min	Max	Units	Fig	Notes
t140	ACSDIN[2:0] Setup to Falling Edge of BITCLK	10	–	ns	22-30	
t141	ACSDIN[2:0] Hold from Falling Edge of BITCLK	10	–	ns	22-30	
t142	ACSYNC, ACSDOUTvalid delay from rising edge of BITCLK	–	15	ns	22-30	
t143	Time duration for which SDO is valid before BITCLK edge.	7	–	ns	22-29	
t144	Time duration for which SDO is valid after BITCLK edge.	7	–	ns	22-29	
t145	Setup time for SDI at rising edge of BITCLK	15	–	ns	22-29	
t146	Hold time for SDI at the rising edge of BITCLK	0	–	ns	22-29	

Table 22-19. LPC Timing

Sym	Parameter	Min	Max	Units	Fig	Notes
t150	LAD[3:0] Valid Delay from PCICLK Rising	2	11	ns	22-2	
t151	LAD[3:0] Output Enable Delay from PCICLK Rising	2	–	ns	22-6	
t152	LAD[3:0] Float Delay from PCICLK Rising		28	ns	22-4	
t153	LAD[3:0] Setup Time to PCICLK Rising	7	–	ns	22-3	
t154	LAD[3:0] Hold Time from PCICLK Rising	0	–	ns	22-3	
t155	LDRQ[1:0]# Setup Time to PCICLK Rising	12	–	ns	22-3	
t156	LDRQ[1:0]# Hold Time from PCICLK Rising	0	–	ns	22-3	
t157	LFRAME# Valid Delay from PCICLK Rising	2	12	ns	22-2	

Table 22-20. Miscellaneous Timings

Sym	Parameter	Min	Max	Units	Fig	Notes
t160	SERIRQ Setup Time to PCICLK Rising	7	–	ns	22-3	
t161	SERIRQ Hold Time from PCICLK Rising	0	–	ns	22-3	
t162	RI#, EXTSMI#, GPI, USB Resume Pulse Width	2	–	RTCCLK	22-5	
t163	SPKR Valid Delay from OSC Rising	–	200	ns	22-2	
t164	SERR# Active to NMI Active	–	200	ns		
t165	IGNNE# Inactive from FERR# Inactive	–	230	ns		

Table 22-21. (Power Sequencing and Reset Signal Timings (Sheet 1 of 2))

Sym	Parameter	Min	Max	Units	Fig	Notes
t200	VccRTC active to RTCRST# inactive	5	–	ms	22-18 22-19	
t201	V5REF_Sus active to VccSus3_3 active	0	–	ms	22-18 22-19	1
t202	VccSus3_3 active to VccSus1_5 active	–	–	–	22-18 22-19	2
t203	VccRTC supply active to VccSus supplies active	0	–	ms	22-18 22-19	3
t204	VccSus supplies active to LAN_RST# inactive, RSMRST# inactive (Desktop Only)	10	–	ms	22-18 22-20	
t205	VccSus supplies active to RSMRST# inactive (Mobile Only)	5	–	ms	22-19 22-21	
t206	VccLAN3_3 active to VccLAN1_5 active (Mobile Only)	–	–	–	22-19	4
t207	VccSus supplies active to VccLAN supplies active (Mobile Only)	0	–	ms	22-19	5
t208	VccLAN supplies active to LAN_RST# inactive (Mobile Only)	10	–	ms	22-19	
t209	V5REF active to Vcc3_3 active	0	–	ms	22-18 22-19	1
t210	Vcc3_3 active to Vcc2_5 active	–	–	–	22-18 22-19	6
t211	Vcc1_5 active to V_CPU_IO active	–	–	–	22-18 22-19	7
t212	VccLAN supplies active to Vcc supplies active (Mobile Only)	0	–	ms	22-19	5
t213	VccSus supplies active to Vcc supplies active (Desktop Only)	0	–	ms	22-18	3
t214	Vcc supplies active to PWROK (S3 _{COLD} only) Note: PWROK assertion indicates that PCICLK has been stable for 1 ms.	99	–	ms	22-18 22-19 22-20 22-21 22-23 22-24 22-25 22-26	
t214a	V_CPU_IO active to VRMPWRGD	10		ms		
t215	Vcc active to STPCLK# and CPUSLP# inactive (Desktop Only)	–	50	ns	22-20 22-23 22-24	
t216	Vcc active to DPRSLPVR inactive and STPCLK#, CPUSLP#, STP_CPU#, STP_PCI#, DPSP# and DPRSTP# inactive (Mobile Only)	–	50	ns	22-21 22-25 22-26	

Table 22-21. (Power Sequencing and Reset Signal Timings (Sheet 2 of 2))

Sym	Parameter	Min	Max	Units	Fig	Notes
t217	PWROK and VRMPWRGD active and SYS_RESET# inactive to SUS_STAT# inactive and Processor I/F signals latched to strap value	32	38	RTCCLK	22-20 22-21 22-23 22-24 22-25 22-26	8, 9
t218	SUS_STAT# inactive to PLTRST# and PCIRST# inactive	2	3	RTCCLK	22-20 22-21 22-23 22-24 22-25 22-26	9
t228	ACZ_RST# active low pulse width	1	–	us		
t229	ACZ_RST# inactive to ACZ_BIT_CLK startup delay	162.8	–	ns		

NOTES:

1. The V5REF supply must power up before its associated 3.3 V supply within 0.7 V, and must power down after the 3.3 V supply within 0.7V. See [Section 2.22.3.1](#) for details.
2. The associated 3.3 V and 1.5 V supplies are assumed to power up or down 'together'. If the integrated VccSus1_5 voltage regulator is **not** used: **a)** VccSus3_3 must power up before VccSus1_5 or after VccSus1_5 within 0.7 V, **b)** VccSus1_5 must power down before VccSus3_3 or after VccSus3_3 within 0.7 V.
3. The VccSus supplies must **never** be active while the VccRTC supply is inactive.
4. (Mobile Only) – **a)** VccLan3_3 must power up before VcclAN1_5 or after VcclAN1_5 within 0.7 V, **b)** VcclAN1_5 must power down before VcclAN3_3 or after VcclAN3_3 within 0.7V.
5. (Mobile Only) - Vcc or VccLAN supplies must never be active while the VccSus supplies are inactive, and the Vcc supplies must never be active while the VcclAN supplies are inactive.
6. If the integrated Vcc2_5 voltage regulator is not used: **a)** Vcc3_3 must power up before Vcc2_5 or after Vcc2_5 within 0.7 V, **b)** Vcc2_5 must power down before Vcc3_3 or after Vcc3_3 within 0.7 V.
7. **a)** Vcc1_5 must power up before V_CPU_IO or after V_CPU_IO within 0.3 V, **b)** V_CPU_IO must power down before Vcc1_5 or after Vcc1_5 within 0.7 V.
8. INIT# value determined by value of the CPU BIST Enable bit (Chipset Configuration Register Offset 3414h: bit 2).
9. These transitions are clocked off the internal RTC. 1 RTC clock is approximately 32 uS.

Table 22-22. Power Management Timings (Sheet 1 of 3)

Sym	Parameter	Min	Max	Units	Fig	Notes
t230	VccSus active to SLP_S5#, SLP_S4#, SLP_S3#, SUS_STAT#, PLTRST# and PCIRST# active	–	50	ns	22-20 22-21	
t231 t232	RSMRST# inactive to SUSCLK running, SLP_S5# inactive	–	110	ms	22-20 22-21	1
t233	SLPS5# inactive to SLP_S4# inactive	See Note Below			22-20 22-21	2
t234	SLPS4# inactive to SLP_S3# inactive	1	2	RTCCCLK	22-20 22-21	3
t250	Processor I/F signals latched prior to STPCLK# active (Mobile Only)	0	–		22-27 22-28 22-29	4
t251	Bus Master Idle to CPU_SLP# active (Mobile Only)	2.88	–	PCICLK	22-28 22-29	5, 6
t252	CPUSLP# active to DPSP# active (Mobile Only)	16	–	PCICLK	22-28 22-29	5
t253	DPSP# active to STP_CPU# active (Mobile Only)	1	1	PCICLK	22-28 22-29	5
t254	STP_CPU# active to processor clock stopped (Mobile Only)	0	–	PCICLK	22-28 22-29	5, 7
t255	STP_CPU# active to DPRSTP#, DPRSLPVR active (Mobile Only)	0	–		22-29	
t265	Break Event to DPRSTP#, DPRSLPVR inactive (C4 Exit) (Mobile Only)	1.5	1.8	µs	22-29	8
t266	DPRSLPVR, DPRSTP# inactive to STP_CPU# inactive and CPU Vcc ramped (Mobile Only)	Programmable. See D31:F0:AA, bits 3:2		µs	22-29	
t267	Break Event to STP_CPU# inactive (C3 Exit) (Mobile Only)	6	Note 14	PCICLK	22-28	5, 9, 10
t268	STP_CPU# inactive to processor clock running (Mobile Only)	0	3	PCICLK	22-28 22-29	5, 7
t269	STP_CPU# inactive to DPSP# inactive (Mobile Only)	1	1	PCICLK	22-28 22-29	5, 11
t270	DPSP# inactive to CPU_SLP# inactive (Mobile Only)	Programmable. See D31:F0:AAh, bits 1:0		µs	22-28 22-29	11
t271	S1 Wake Event to CPUSLP# inactive (Desktop Only)	1	25	PCICLK	22-22	5
t272	CPUSLP# inactive to STPCLK# inactive (Mobile Only)	0	–	µs	22-28 22-29	
t273	Break Event to STPCLK# inactive (C2 Exit) (Mobile Only)	0	–	ns	22-27	

Table 22-22. Power Management Timings (Sheet 2 of 3)

Sym	Parameter	Min	Max	Units	Fig	Notes
t274	STPCLK# inactive to processor I/F signals unlatched (Mobile Only)	8	9	PCICLK	22-27 22-28 22-29	4, 5
t280	STPCLK# active to DMI Message	0	–	PCICLK	22-22 22-23 22-24 22-25 22-26	12
t281	DMI Message to CPUSLP# active	60	63	PCICLK	22-22	5
t283	DMI Message to SUS_STAT# active	2	–	RTCCLK	22-23 22-24 22-25 22-26	3
t284	SUS_STAT# active to PLTRST#, PCIRST# active (Desktop Only)	7	17	RTCCLK	22-23 22-24	3
t285	SUS_STAT# active to STP_PCI# active (Mobile Only)	2	10	RTCCLK	22-25 22-26	3
t286	STP_PCI# active to PLTRST# and PCIRST# active (Mobile Only)	5	7	RTCCLK	22-25 22-26	3
t287	PLTRST#, PCIRST# active to SLP_S3# active	1	2	RTCCLK	22-23 22-24 22-25 22-26	3
t288	(S3 _{COLD} Configuration Only) SLP_S3# active to PWROK, VRMPWRGD inactive (Mobile Only)	0	–	ms	22-25	13
t289	SLP_S3# active to PWROK, VRMPWRGD inactive (Desktop Only)	0	–	ms	22-23	13
t290	(S3 _{COLD} Configuration Only) PWROK, VRMPWRGD inactive to Vcc supplies inactive (Mobile Only)	20	–	ns	22-25	
t291	SLP_S3# active to SLP_S4# active	1	2	RTCCLK	22-23 22-24 22-25 22-26	3
t292	(S3 _{HOT} Configuration Only) SLP_S3# active to VRMPWRGD inactive	0	–	ms	22-24 22-26	13
t293	(S3 _{HOT} Configuration Only) PWROK, VRMPWRGD inactive to Vcc supplies inactive	20	–	ns	22-24 22-26	
t294	PWROK, VRMPWRGD inactive to Vcc supplies inactive (Desktop Only)	20	–	ns	22-23	
t295	SLP_S4# active to SLP_S5# active	1	–2	RTCCLK	22-23 22-24 22-25 22-26	3, 14
t296	Wake Event to SLP_S5# inactive	1	10	RTCCLK	22-23 22-24 22-25 22-26	3

Table 22-22. Power Management Timings (Sheet 3 of 3)

Sym	Parameter	Min	Max	Units	Fig	Notes
t297	SLP_S5# inactive to SLP_S4# inactive	See Note Below			22-23 22-24 22-25 22-26	2
t298	SLP_S4# inactive to SLP_S3# inactive	1	2	RTCCLK	22-23 22-24 22-25 22-26	3
t299	S4 Wake Event to SLP_S4# inactive (S4 Wake)	See Note Below			22-23 22-24 22-25 22-26	2
t300	S3 Wake Event to SLP_S3# inactive (S3 Wake)	0	small as possi ble	RTCCLK	22-23 22-24 22-25 22-26	3
t301	CPUSLP# inactive to STPCLK# inactive (Desktop Only)	8	–	PCICLK	22-22	
t302	(S3 _{HOT} Configuration Only) SLP_S3# inactive to ICH6 check for PWROK active	4	5	msec	22-23 22-24 22-25 22-26	
Other Timings						
t310	THRMTRIP# active to SLP_S3#, SLP_S4#, SLP_S5# active	–	2	PCI CLK		

NOTES:

1. If there is no RTC battery in the system, so VccRTC and the VccSus supplies come up together, the delay from RTCRST# and RSMRST# inactive to SUSCLK toggling may be as much as 2.5 s.
2. The Min/Max times depend on the programming of the “SLP_S4# Minimum Assertion Width” and the “SLP_S4# Assertion Stretch Enable bits (D31:F0:A4h bits 5:3).
3. These transitions are clocked off the internal RTC. 1 RTC clock is approximately 32 μ s.
4. Note that this does not apply for synchronous SMIs.
5. These transitions are clocked off the 33 MHz PCICLK. 1 PCICLK is approximately 30ns.
6. If the (G)MCH does not have the CPUSLP# signal, then the minimum value can be 0 μ s.
7. This is a clock generator specification
8. This is non-zero to enforce the minimum assert time for DPRSLPVR. If the minimum assert time for DPRSLPVR has been met, then this is permitted to be 0.
9. This is non-zero to enforce the minimum assert time for STP_CPU#. If the minimum assert time for STP_CPU# has been met, then this is permitted to be 0.
10. This value should be at most a few clocks greater than the minimum.
11. This value is programmable in multiples of 1024 PCI clocks. Maximum is 8192 PCI clocks (245.6 μ s).
12. The ICH6 STPCLK# assertion will trigger the processor to send a stop grant acknowledge cycle. The timing for this cycle getting to the ICH6 is dependant on the processor and the memory controller.
13. The ICH6 has no maximum timing requirement for this transition. It is up to the system designer to determine if the SLP_S3#, SLP_S4# and SLP_S5# signals are used to control the power planes.
14. If the transition to S5 is due to Power Button Override, SLP_S3#, SLP_S4# and SLP_S5# are asserted together similar to timing t287 (PCIRST# active to SLP_S3# active).

22.5 Timing Diagrams

Figure 22-1. Clock Timing

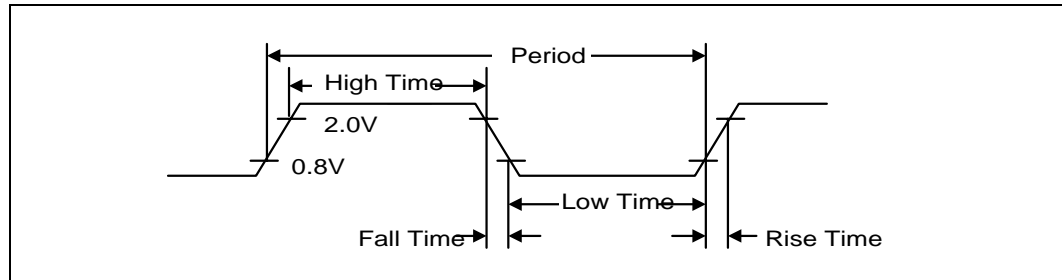

Figure 22-2. Valid Delay from Rising Clock Edge

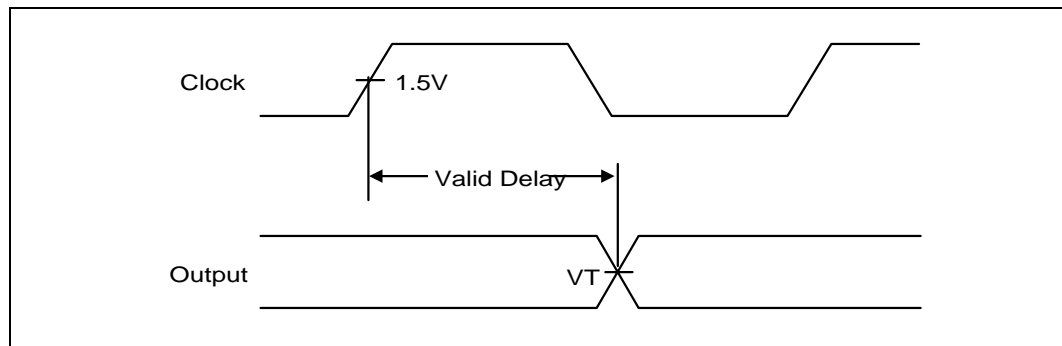

Figure 22-3. Setup and Hold Times

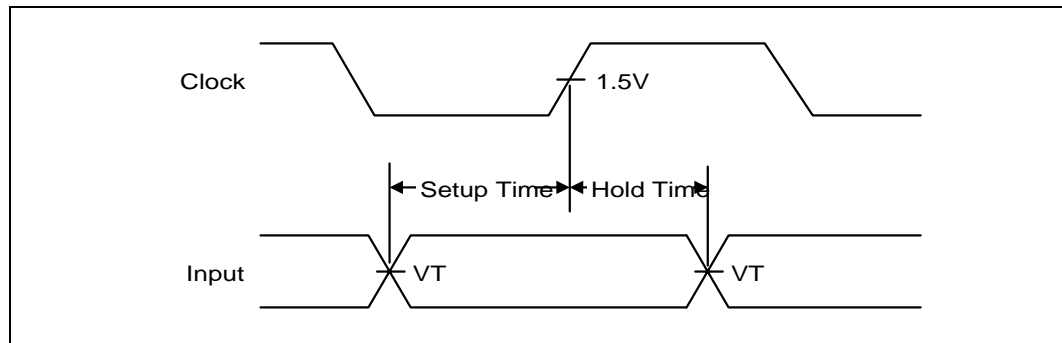

Figure 22-4. Float Delay

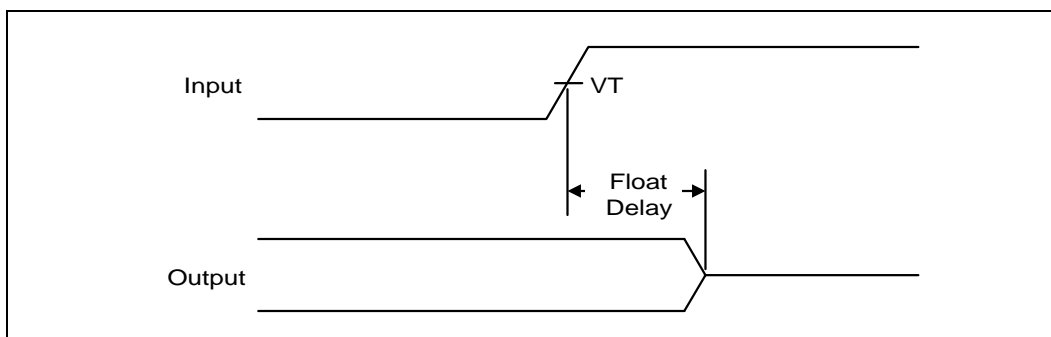

Figure 22-5. Pulse Width

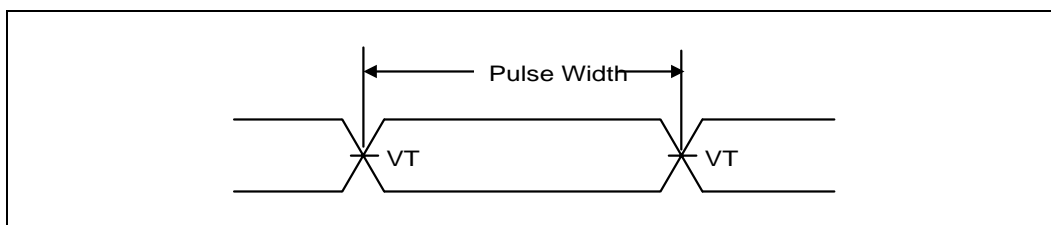

Figure 22-6. Output Enable Delay

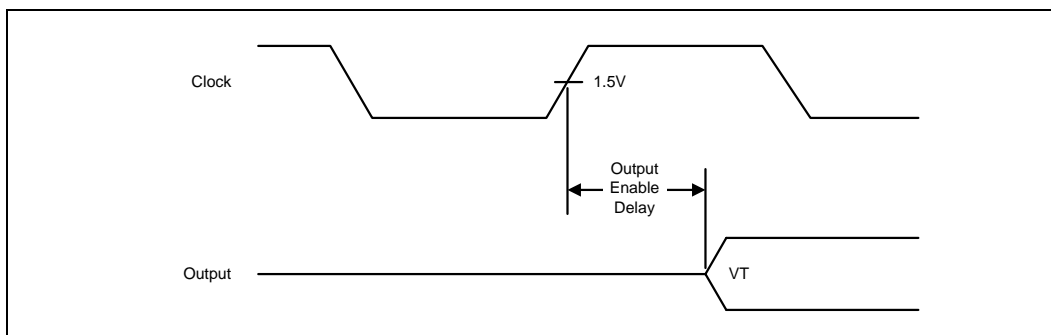

Figure 22-7. IDE PIO Mode

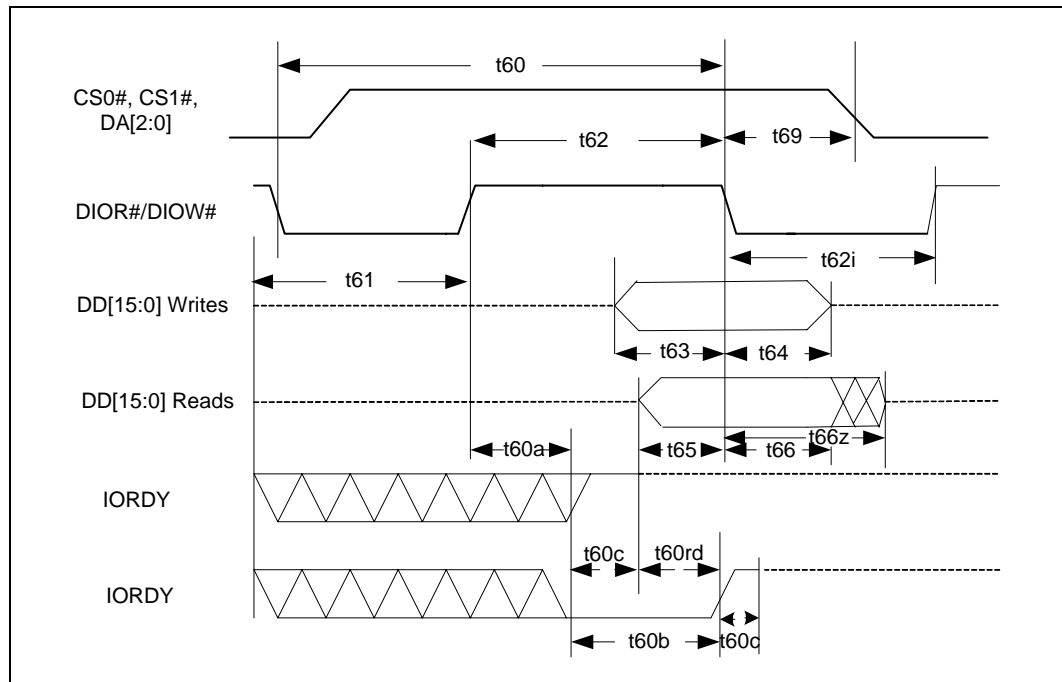

Figure 22-8. IDE Multiword DMA

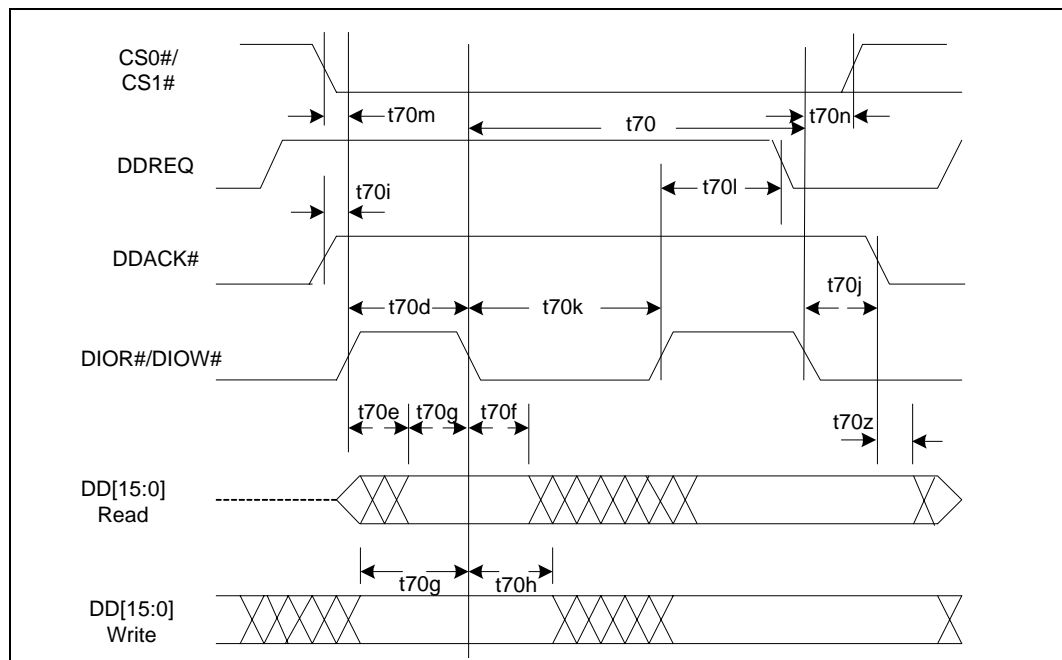

Figure 22-9. Ultra ATA Mode (Drive Initiating a Burst Read)

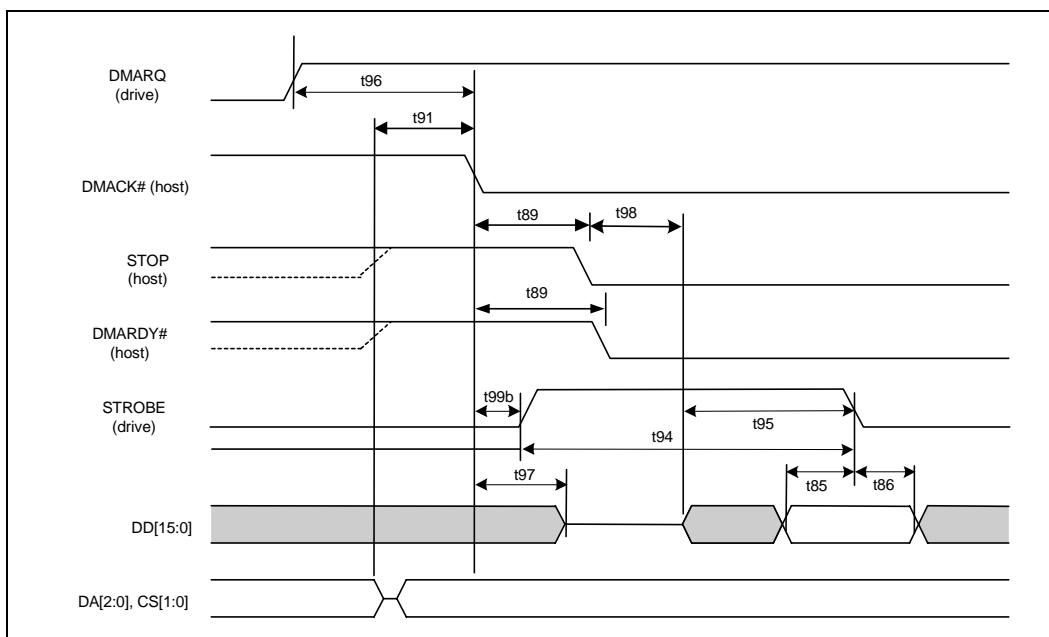

Figure 22-10. Ultra ATA Mode (Sustained Burst)

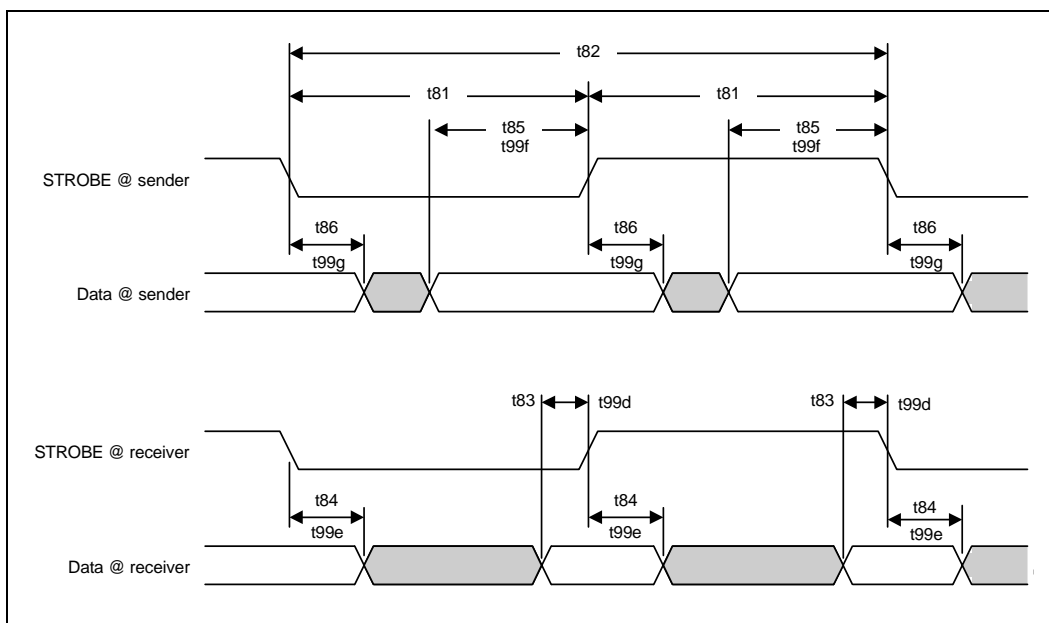

Figure 22-11. Ultra ATA Mode (Pausing a DMA Burst)

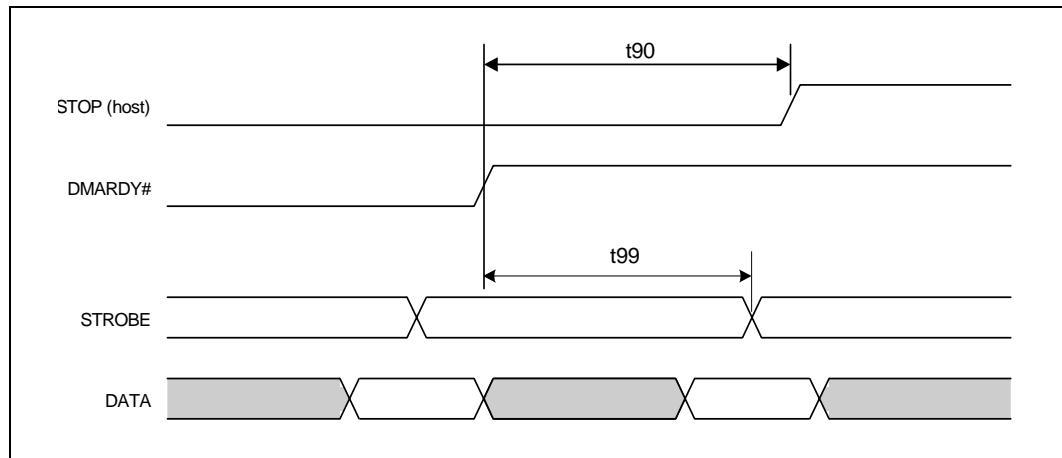

Figure 22-12. Ultra ATA Mode (Terminating a DMA Burst)

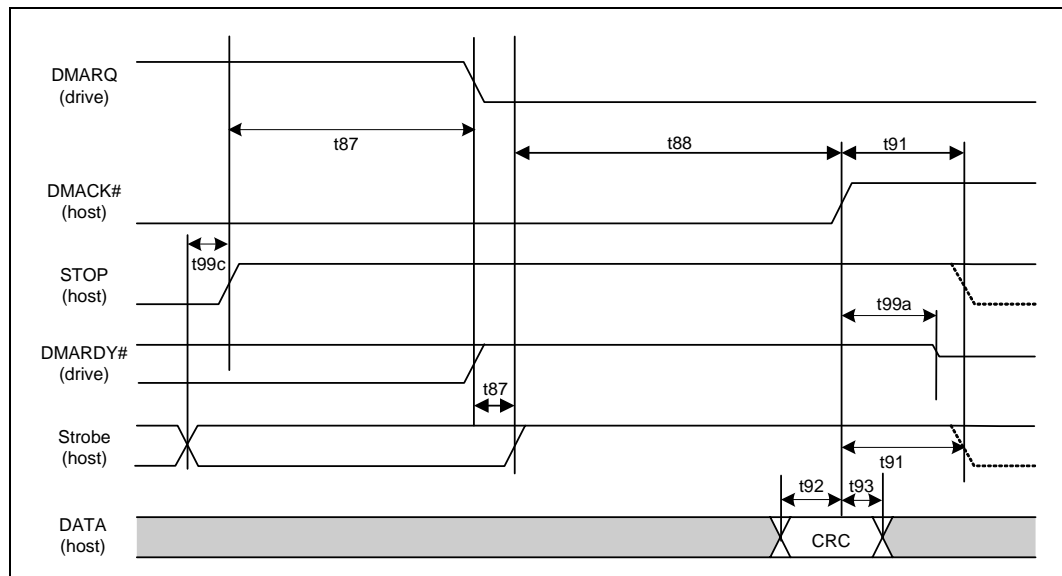

Figure 22-13. USB Rise and Fall Times

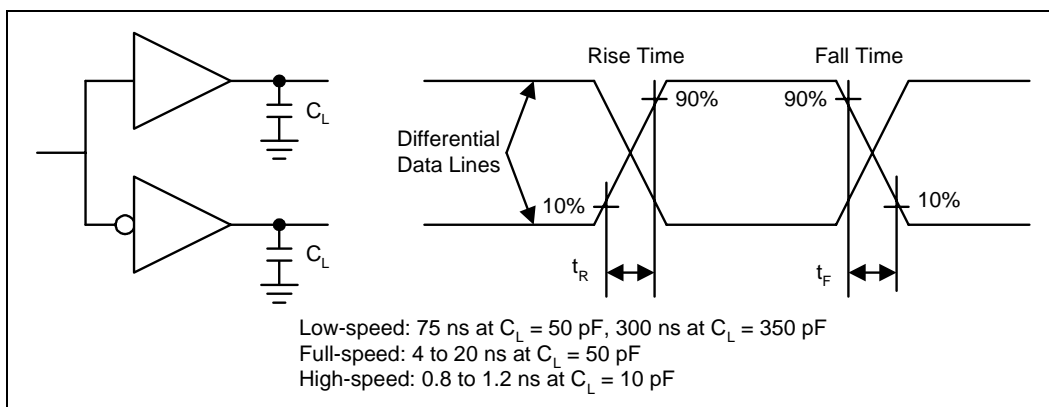

Figure 22-14. USB Jitter

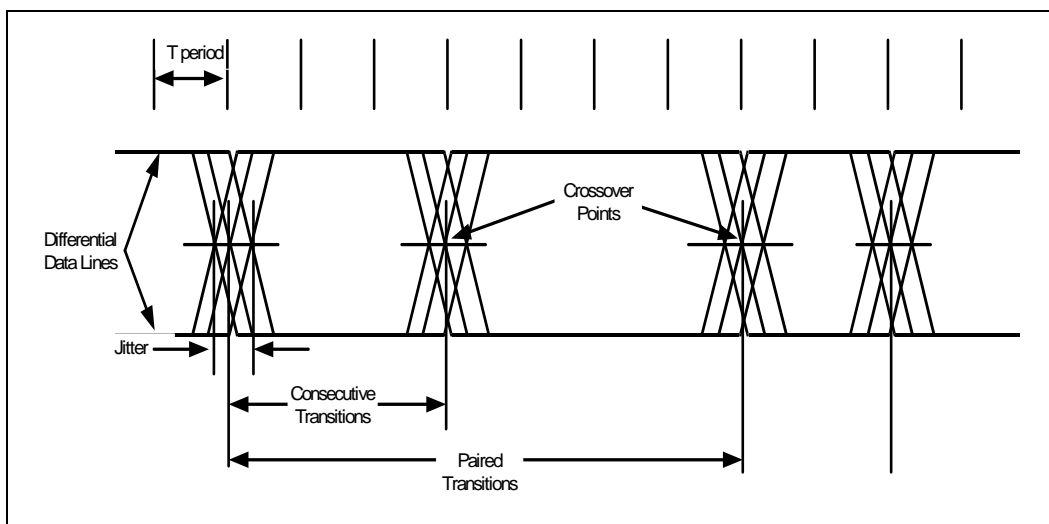

Figure 22-15. USB EOP Width

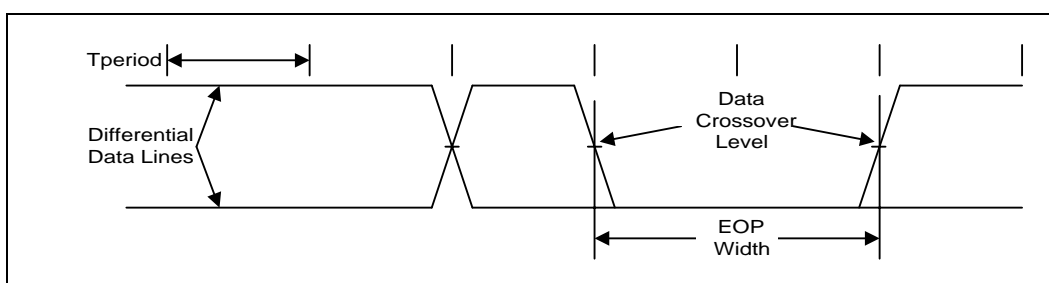

Figure 22-16. SMBus Transaction

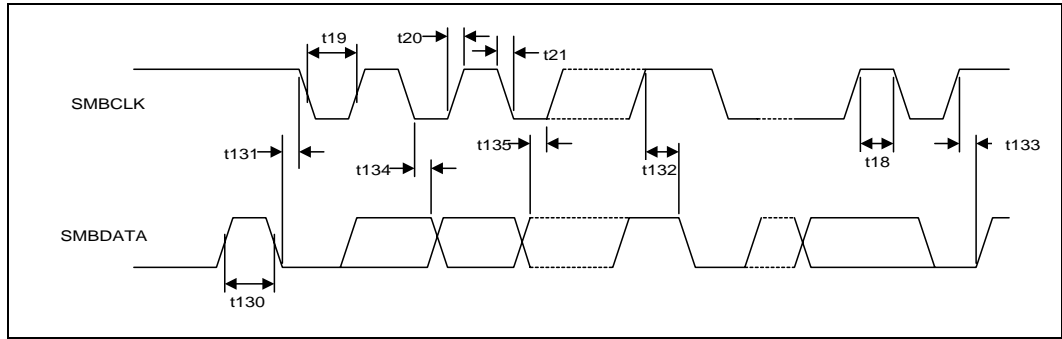

Figure 22-17. SMBus Timeout

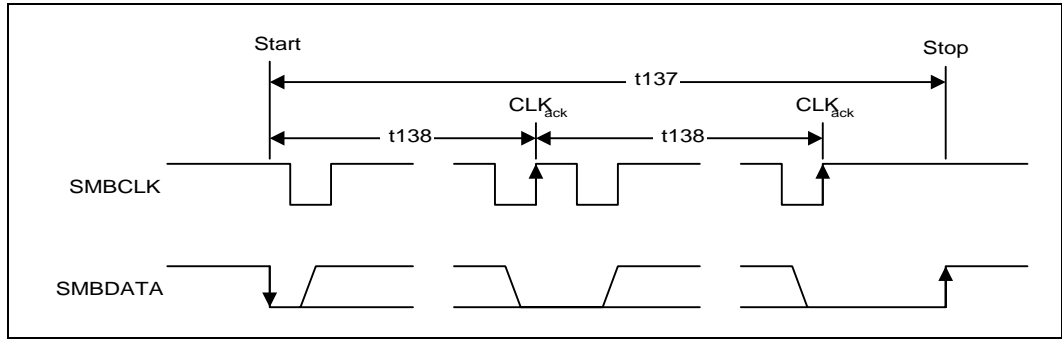

Figure 22-18. Power Sequencing and Reset Signal Timings (Desktop Only)

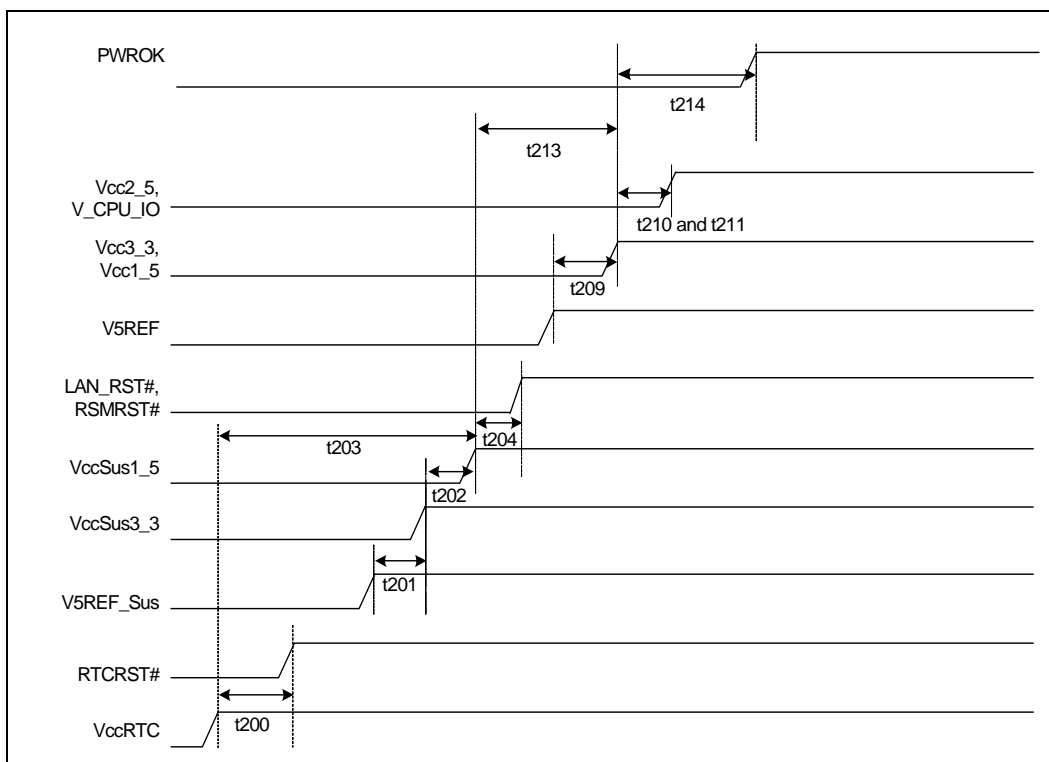

Figure 22-19. Power Sequencing and Reset Signal Timings (Mobile Only)

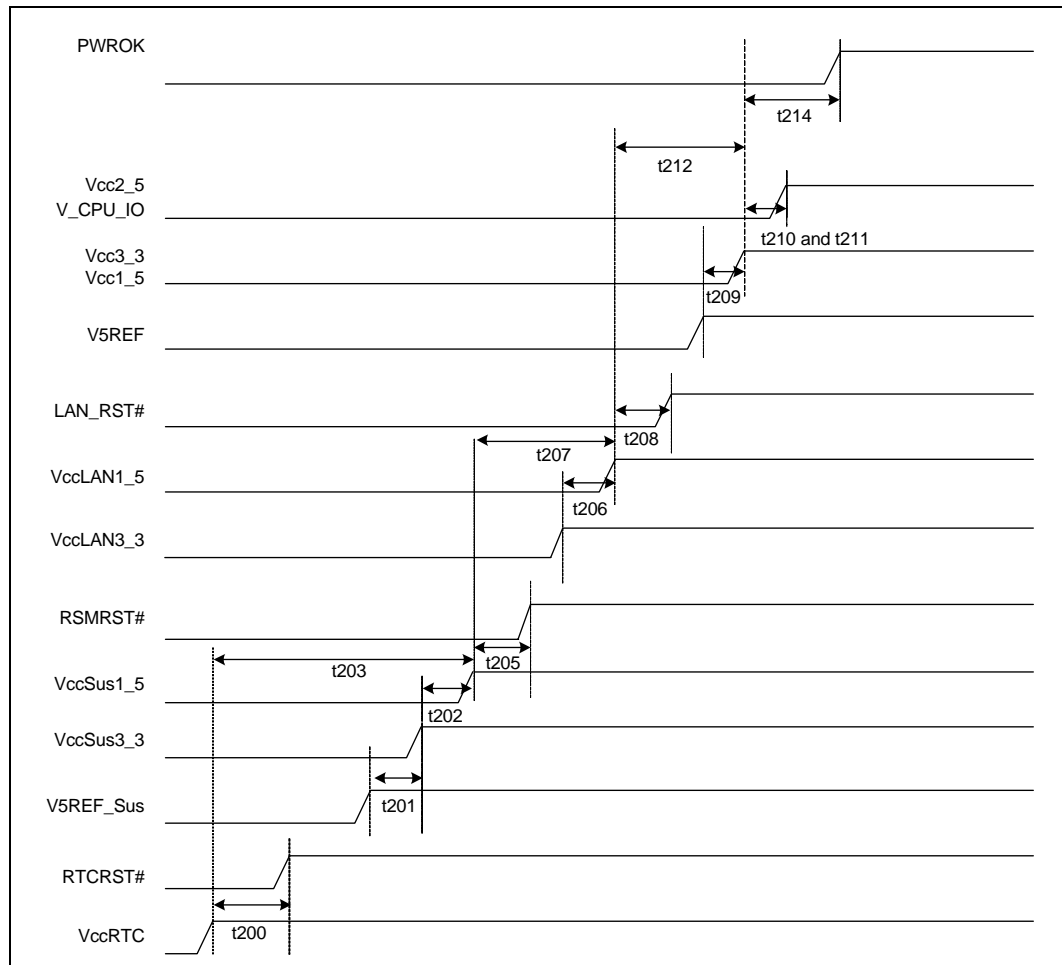

Figure 22-20. G3 (Mechanical Off) to S0 Timings (Desktop Only)

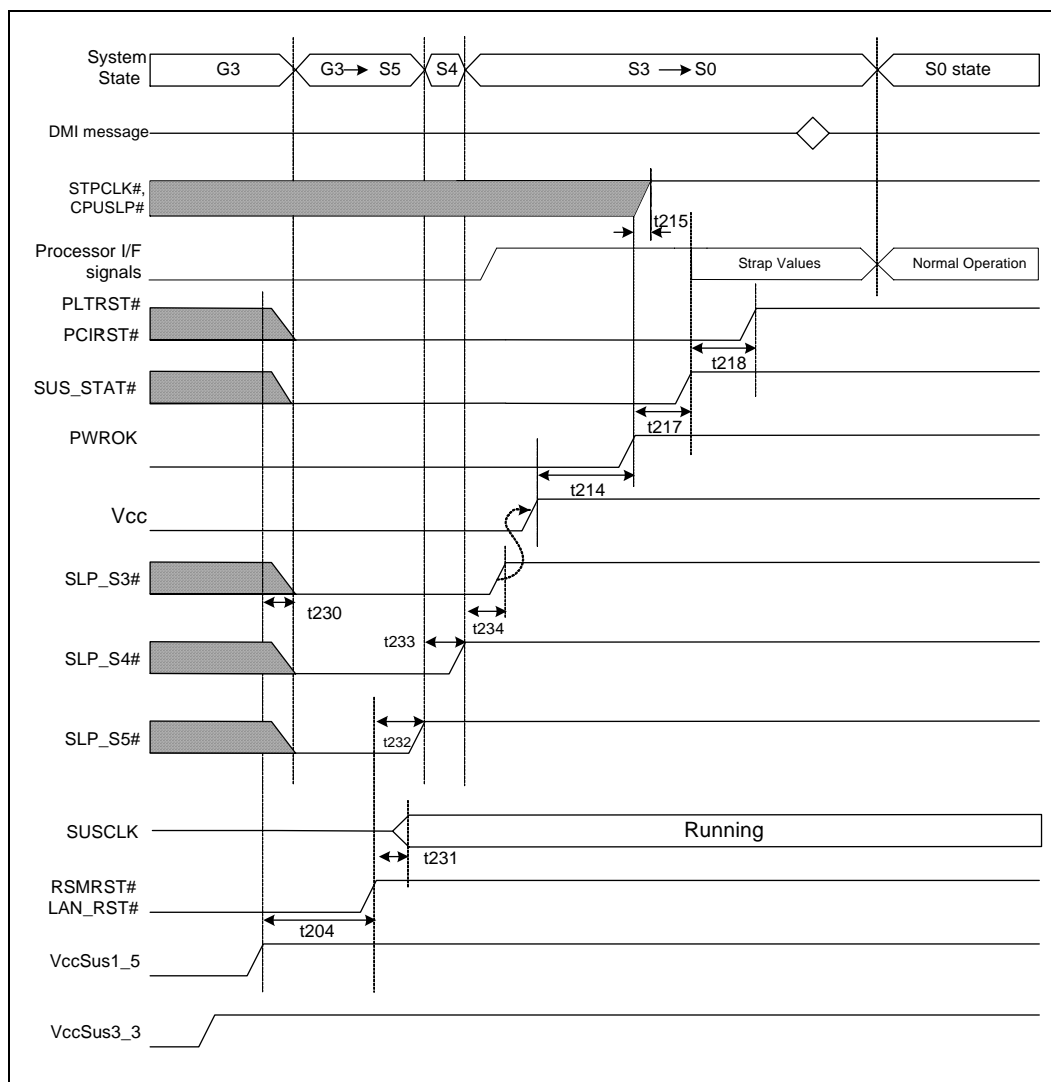

Figure 22-21. G3 (Mechanical Off) to S0 Timings (Mobile Only)

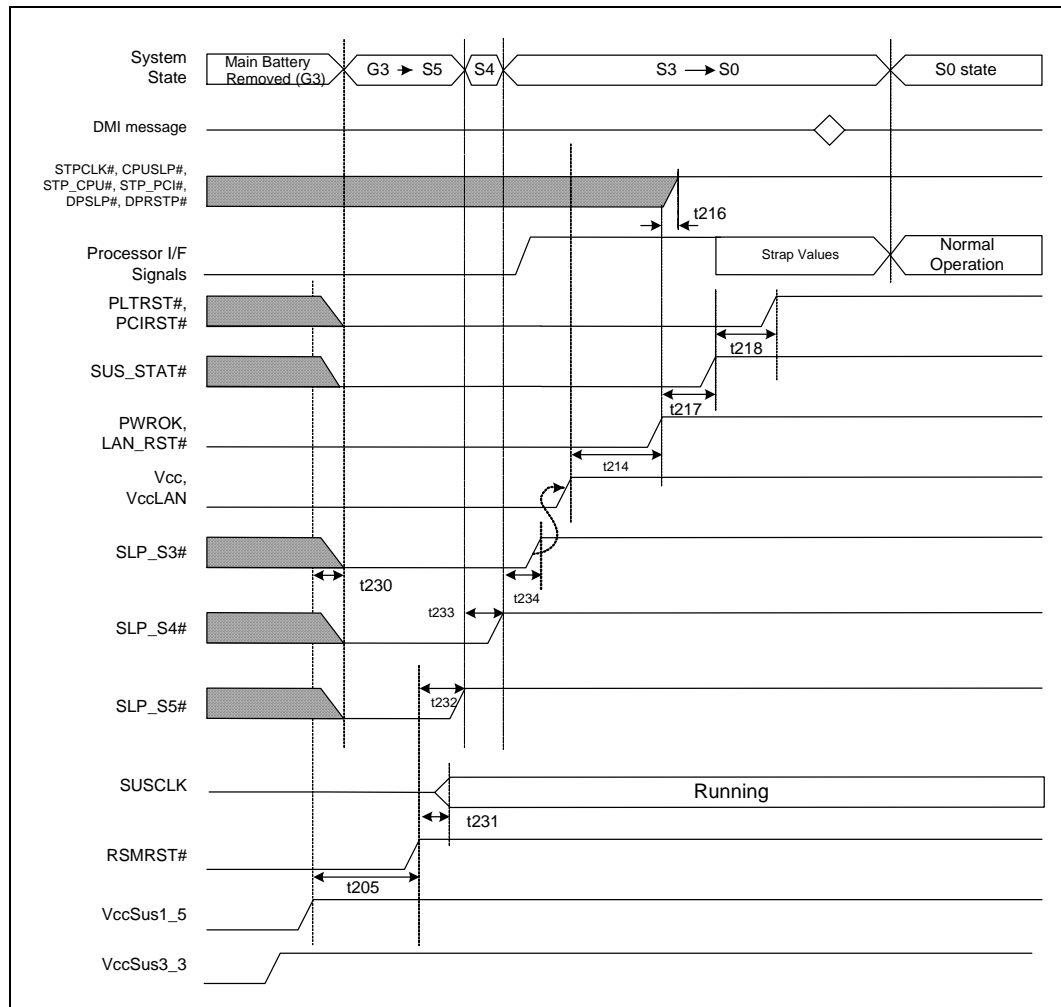

Figure 22-22. S0 to S1 to S0 Timing

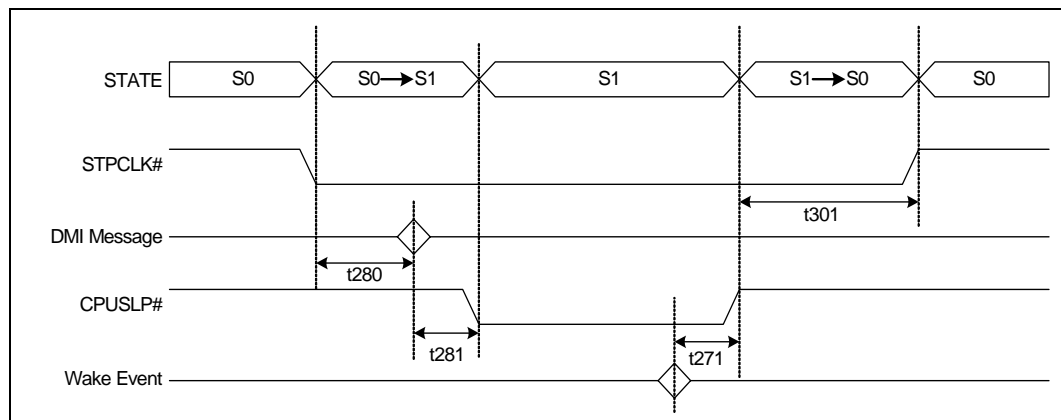

Figure 22-23. S0 to S5 to S0 Timings, S3_{COLD}(Desktop Only)

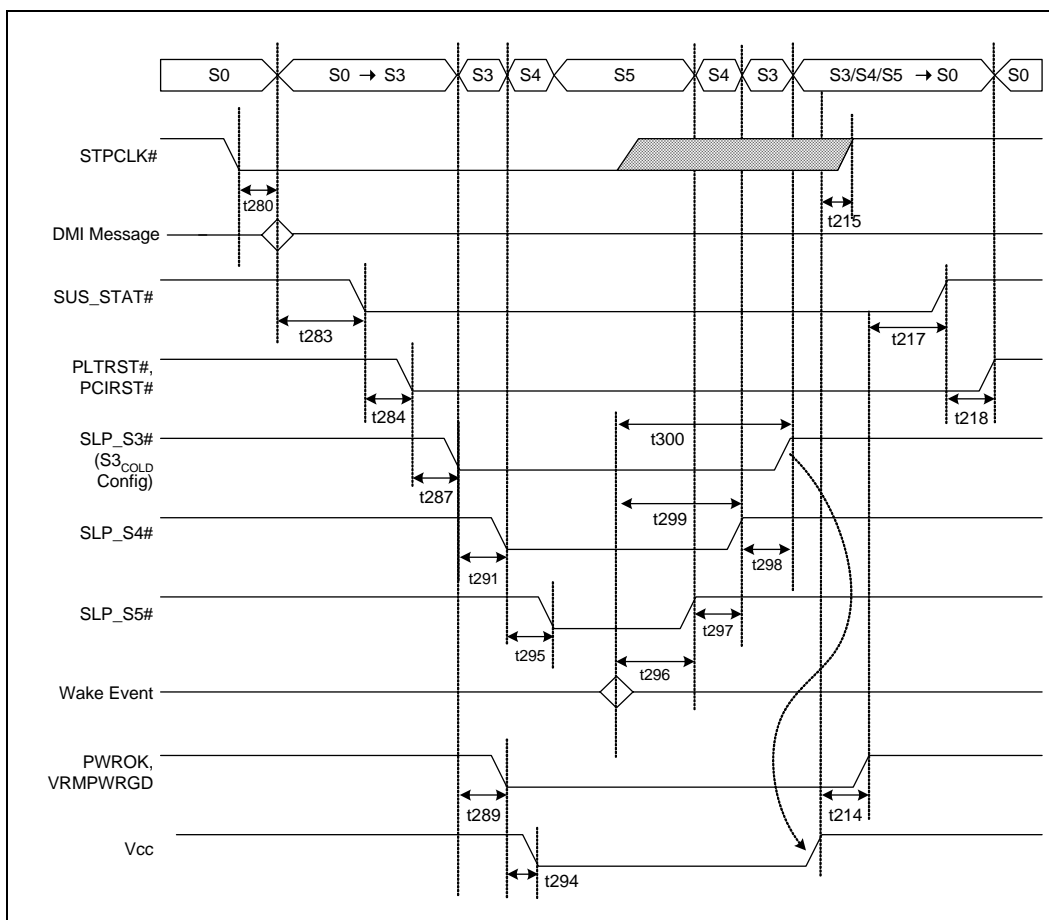

Figure 22-24. S0 to S5 to S0 Timings, S3_{HOT} (Desktop Only)

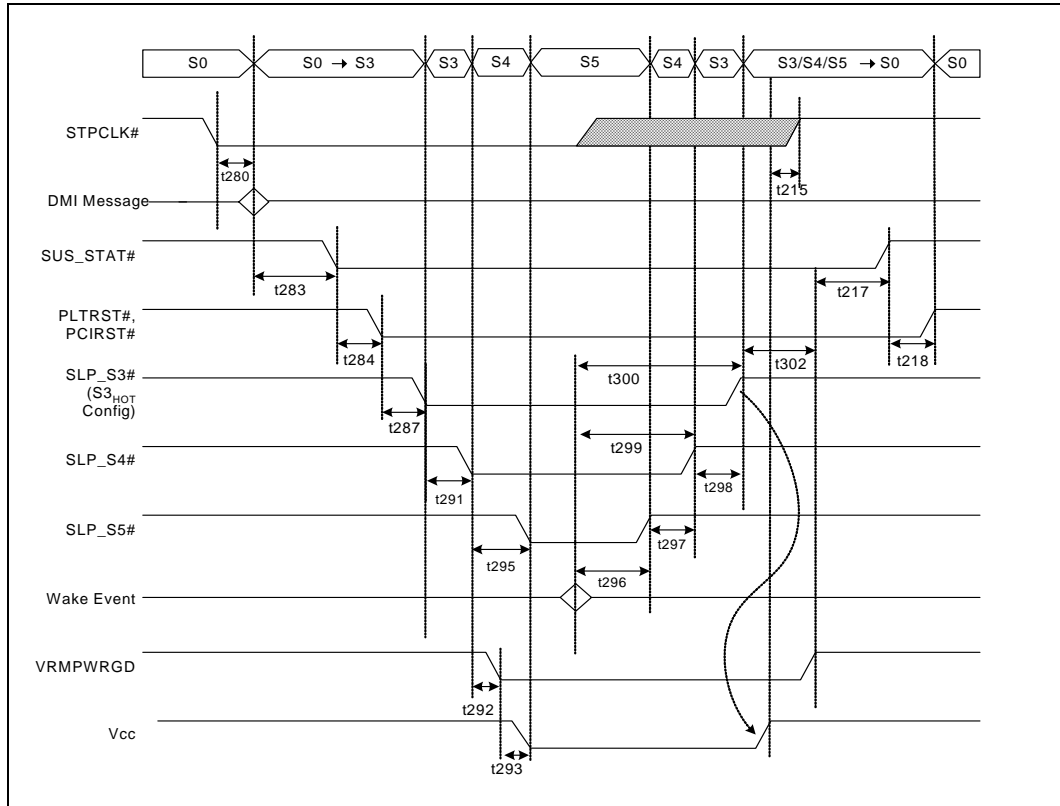

Figure 22-25. S0 to S5 to S0 Timings, S3_{COLD} (Mobile Only)

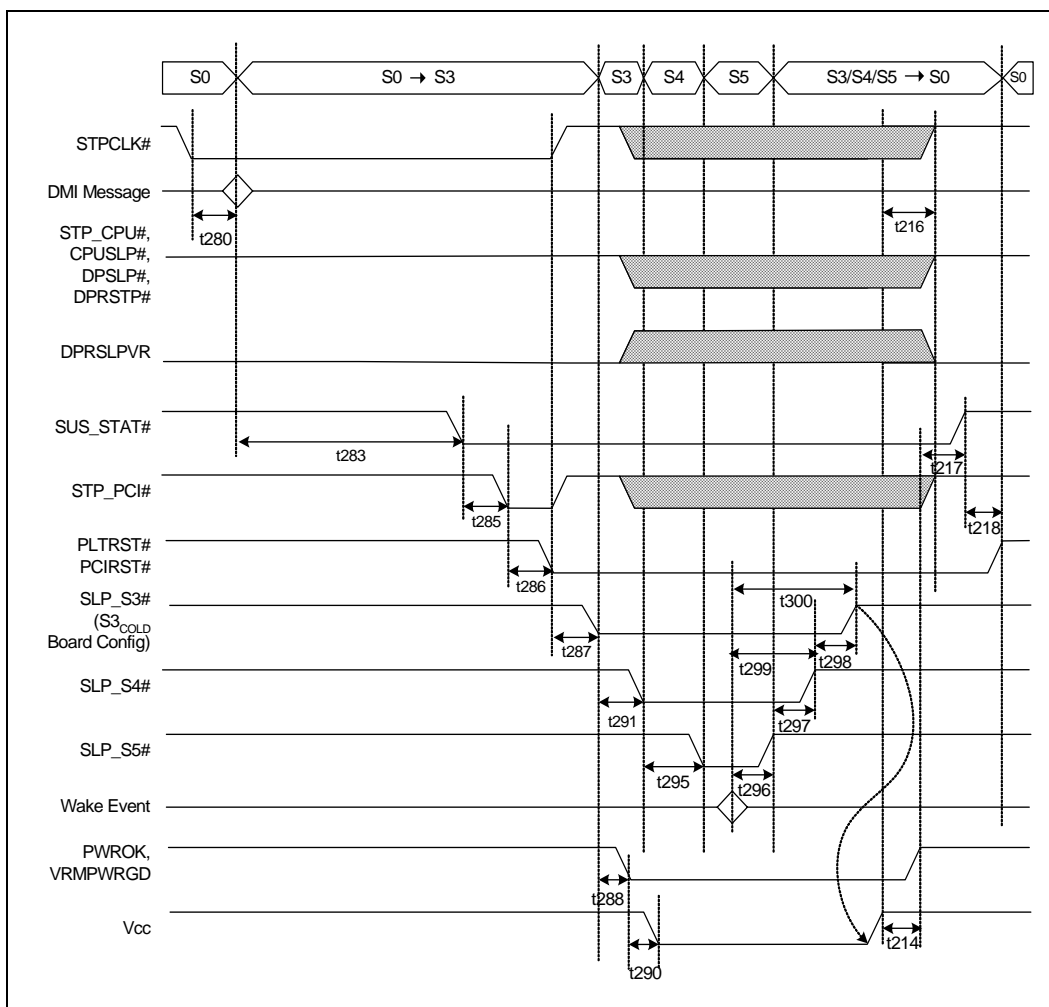

Figure 22-26. S0 to S5 to S0 Timings, S3_{HOT} (Mobile Only)

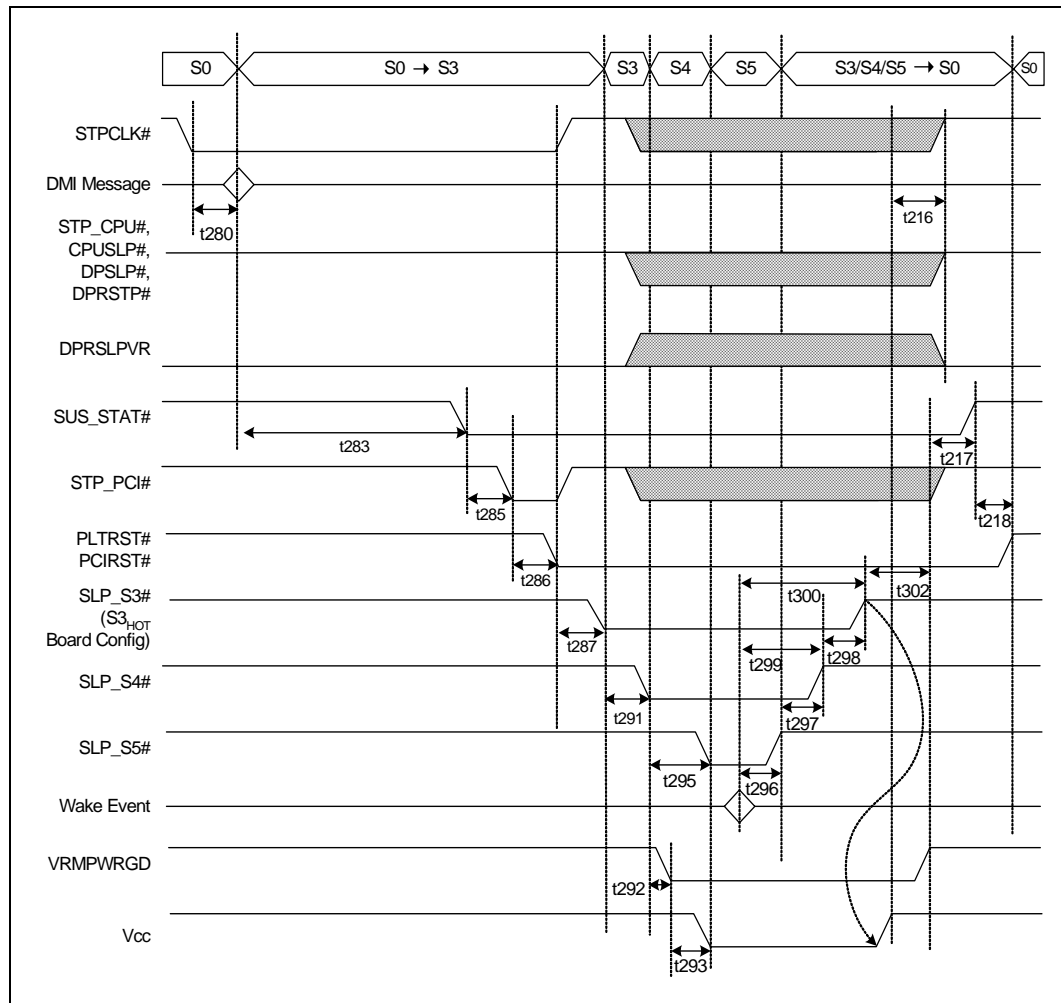

Figure 22-27. C0 to C2 to C0 Timings (Mobile Only)

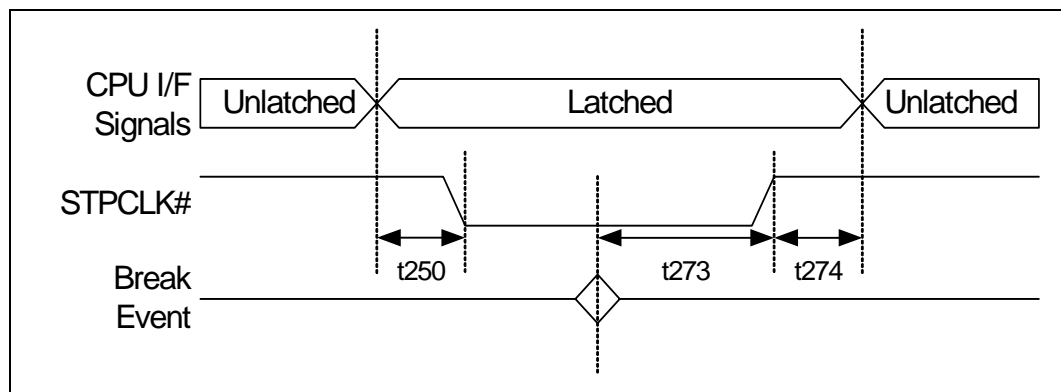

Figure 22-28. C0 to C3 to C0 Timings (Mobile Only)

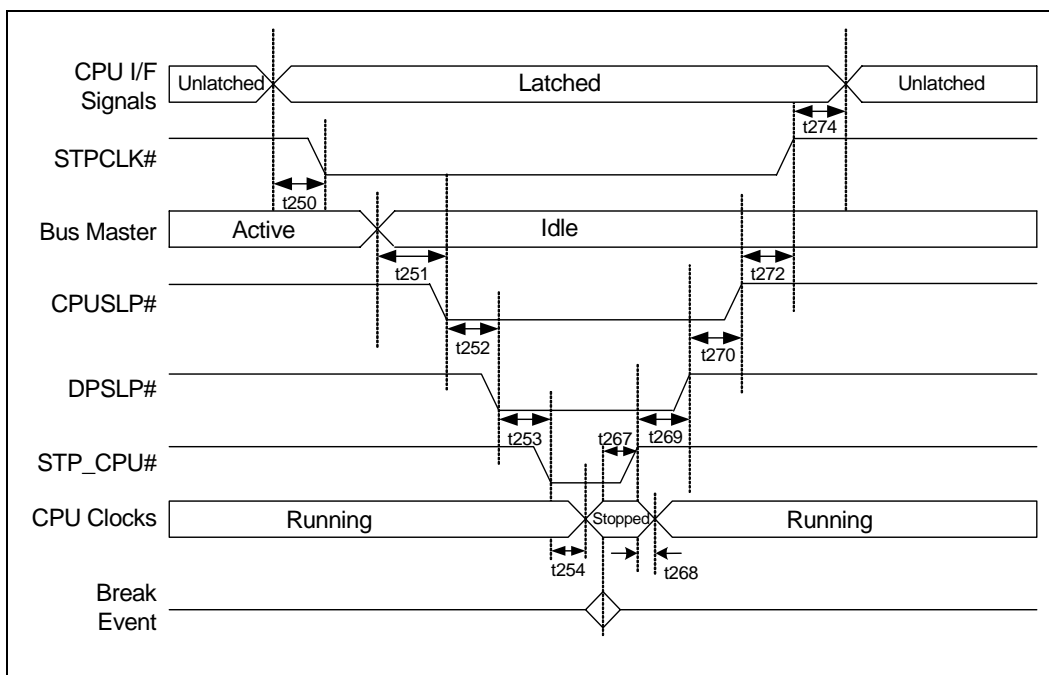

Figure 22-29. C0 to C4 to C0 Timings (Mobile Only)

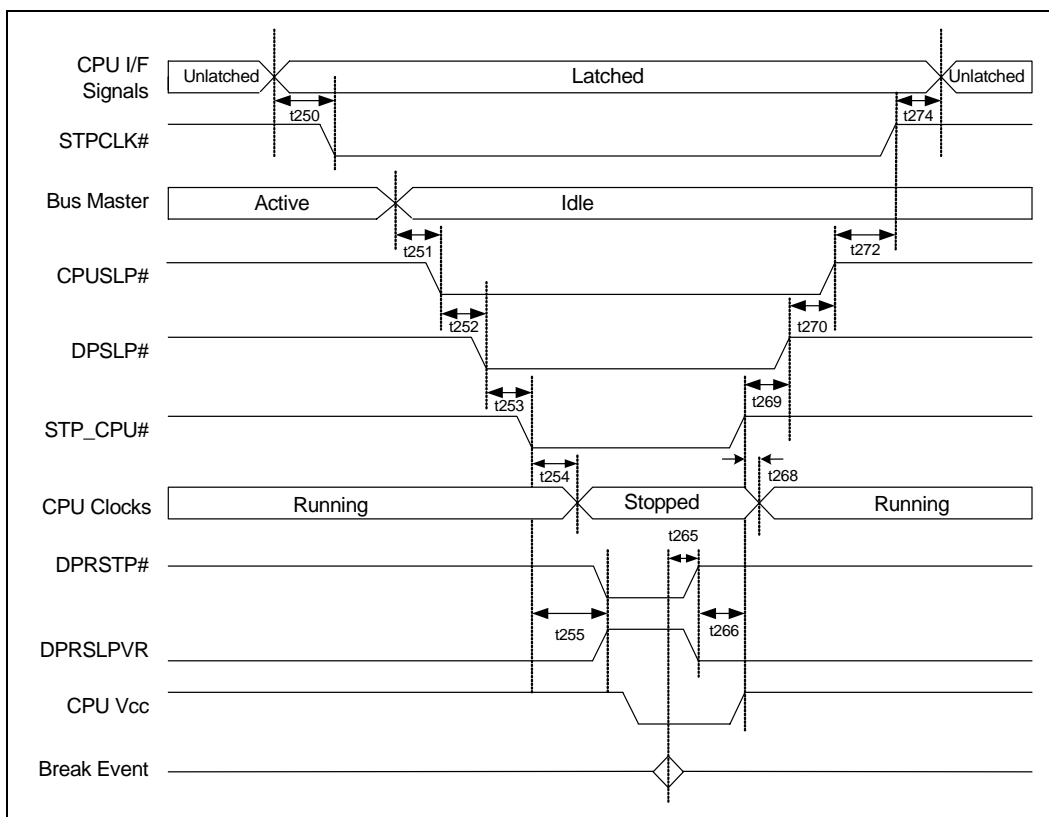

Figure 22-30. AC '97 Data Input and Output Timings

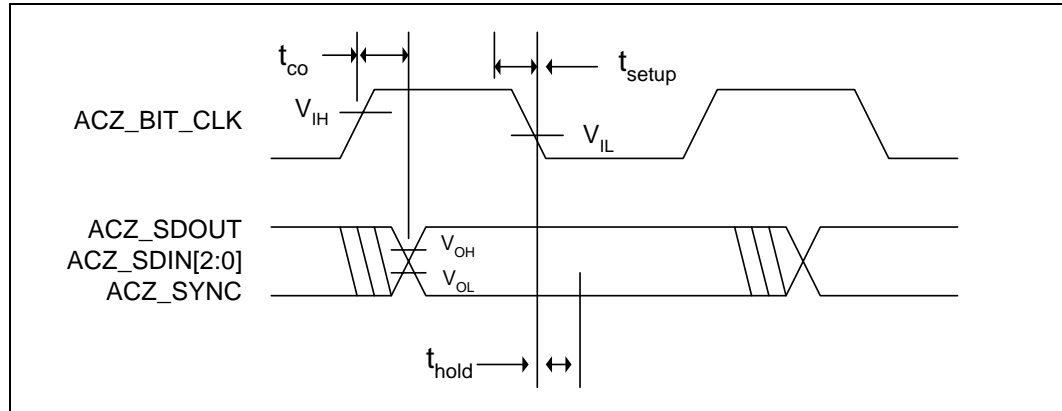
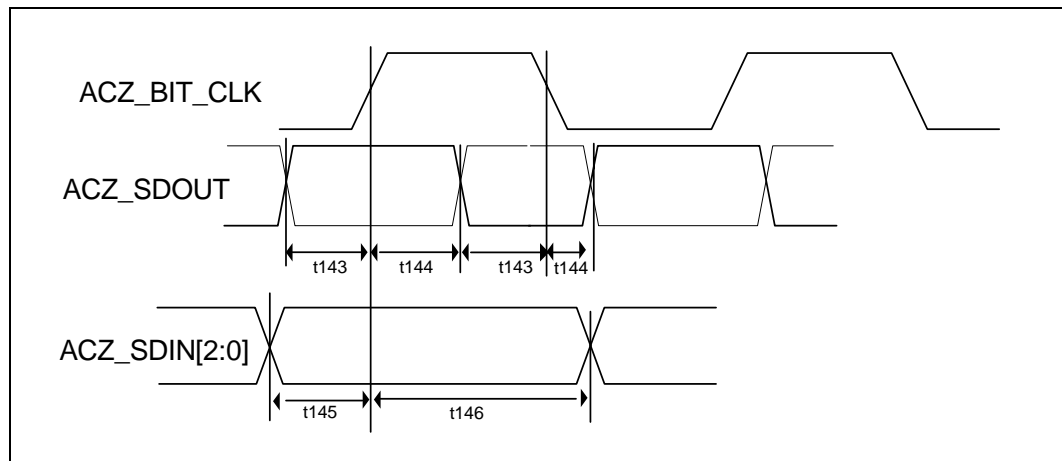

Figure 22-31. Intel® High Definition Audio Input and Output Timings



§



23 Package Information

The ICH6 package information is shown in Figure 23-1 and Figure 23-2. The figures are preliminary and subject to change.

Figure 23-1. Intel® ICH6 Package (Top and Side Views)

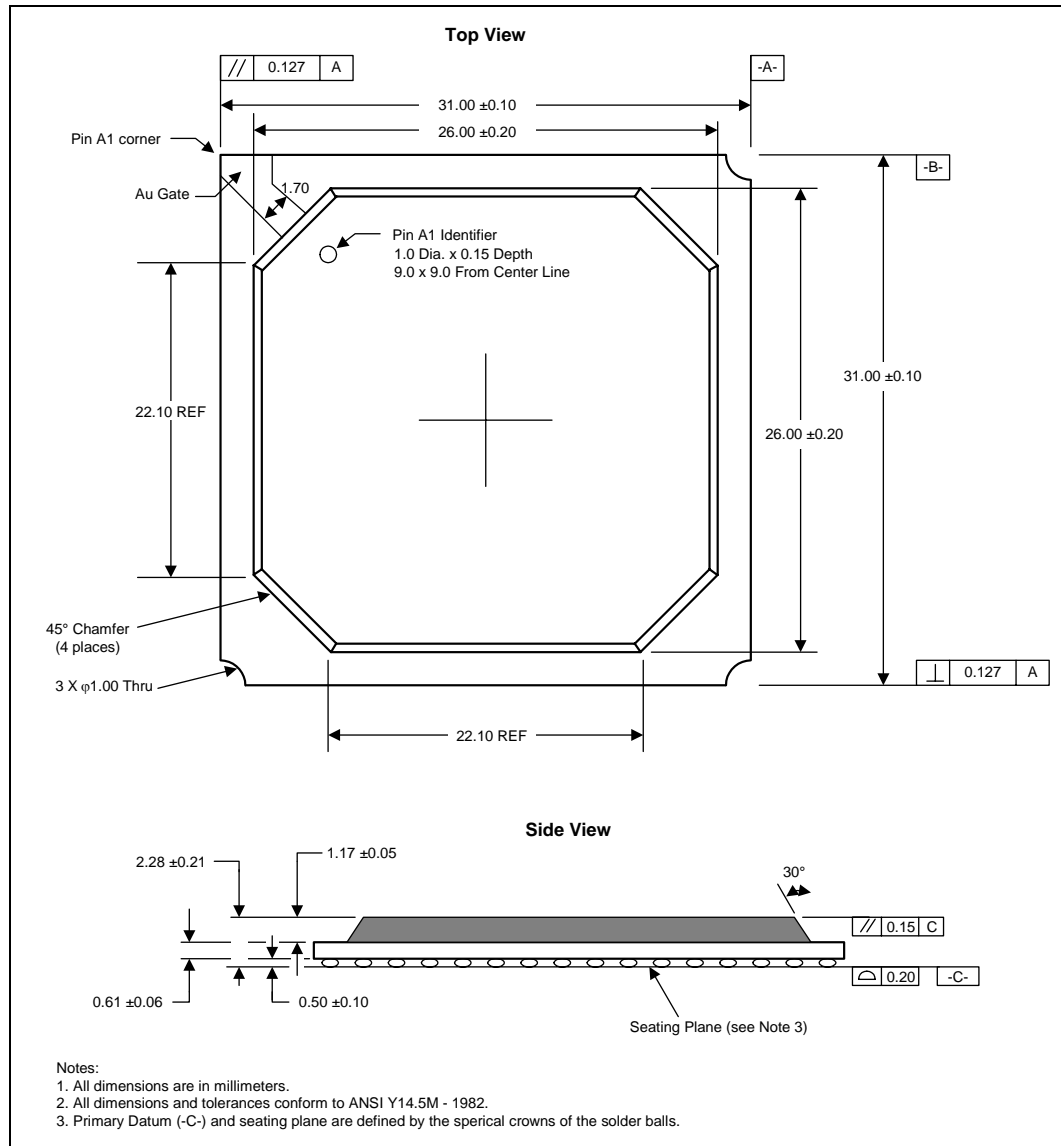
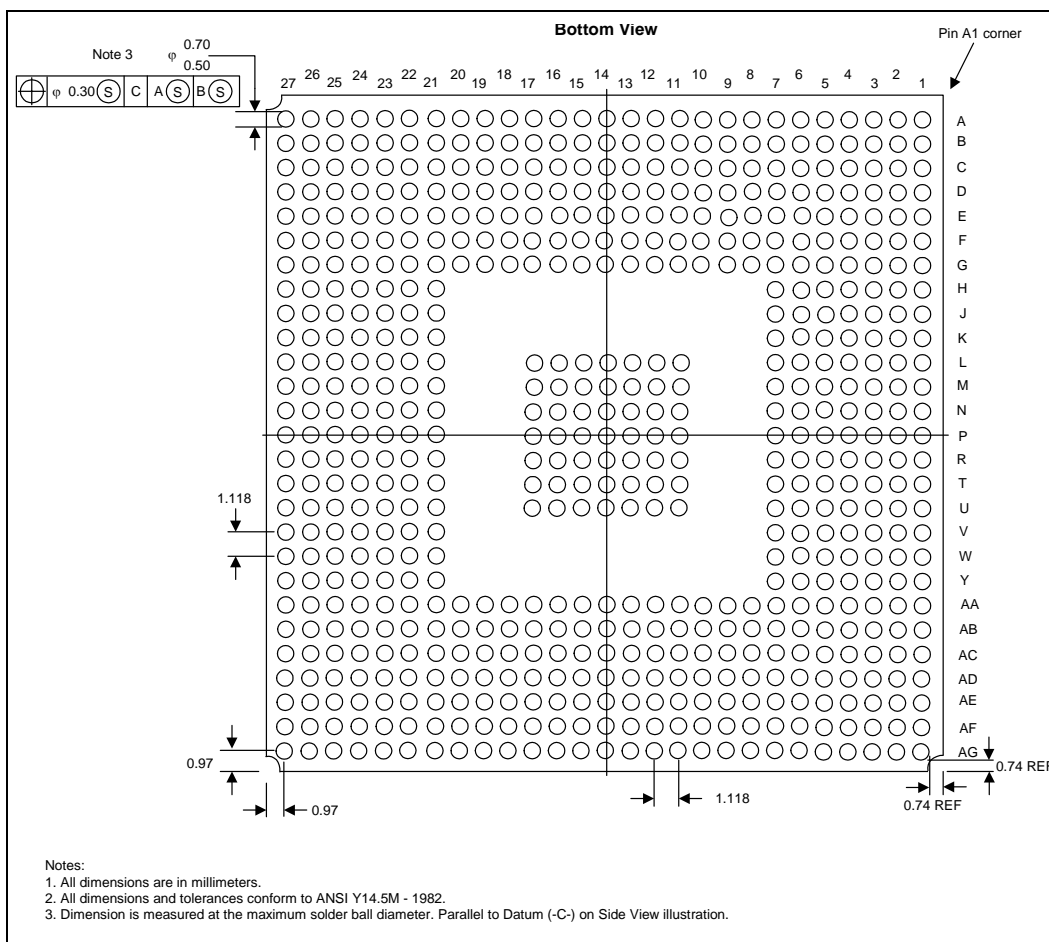

Figure 23-2. Intel® ICH6 Package (Bottom View)



§

24 Testability

24.1 XOR Chain Test Mode Description

The Intel® ICH6 supports XOR Chain test mode. This non-functional test mode is a dedicated test mode when the chip is not operating in its normal manner. The XOR Chain Mode is entered as indicated in the following figure:

Figure 24-1. XOR Chain Test Mode Selection, Entry and Testing

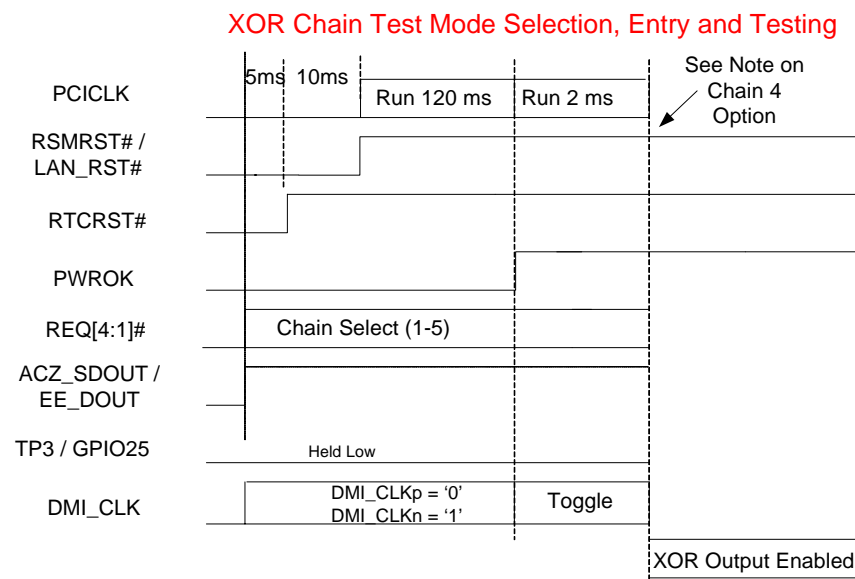

Notes: RSMRST#, PWROK, RTCRST#, LAN_RST# must be held high during test mode and output testing.

PCICLK & DMI_CLK should be approximately 1 MHz while running/toggling

Chain 4 Combination Option:

If LAN_RST# = 0 during testing (XOR Output Enabled) then Chains 4-1 and 4-2 are separate.

If LAN_RST# = 1 during testing then Chains 4-1 and 4-2 are combined with output on PLTRST#.

LAN_RST# must be high for all other chains

For chains 4 and 5, all PETx[n] signals (of that chain) must be driven during testing.

REQ# Settings	XOR Chain
REQ[4:1]# = 0000	XOR 1
REQ[4:1]# = 0001	XOR 2
REQ[4:1]# = 0010	XOR 3
REQ[4:1]# = 0011	XOR 4
REQ[4:1]# = 0100	XOR 5

Figure 24-2. Example XOR Chain Circuitry

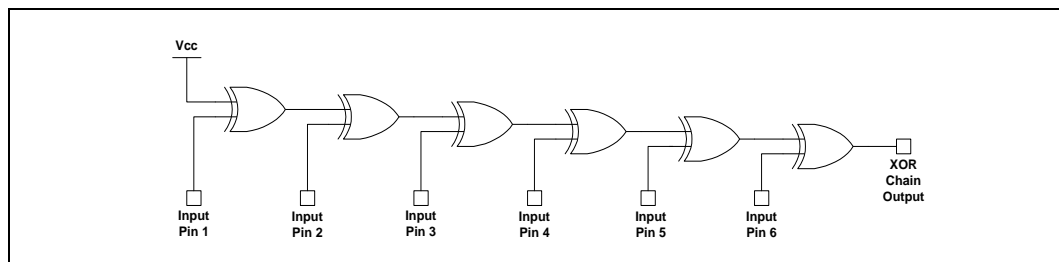

24.1.1 XOR Chain Testability Algorithm Example

XOR chain testing allows motherboard manufacturers to check component connectivity (e.g., opens and shorts to VCC or GND). An example algorithm to do this is shown in [Table 24-1](#).

Table 24-1. XOR Test Pattern Example

Vector	Input Pin 1	Input Pin 2	Input Pin 3	Input Pin 4	Input Pin 5	Input Pin 6	XOR Output
1	0	0	0	0	0	0	1
2	1	0	0	0	0	0	0
3	1	1	0	0	0	0	1
4	1	1	1	0	0	0	0
5	1	1	1	1	0	0	1
6	1	1	1	1	1	0	0
7	1	1	1	1	1	1	1

In this example, Vector 1 applies all 0's to the chain inputs. The outputs being non-inverting will consistently produce a 1 at the XOR output on a good board. One short to VCC (or open floating to VCC) will result in a 0 at the chain output, signaling a defect.

Likewise, applying Vector 7 (all 1's) to the chain inputs (given that there are an even number of input signals in the chain), will consistently produce a 1 at the XOR chain output on a good board. One short to VSS (or open floating to VSS) will result in a 0 at the chain output, signaling a defect. It is important to note that the number of inputs pulled to 1 will affect the expected chain output value. If the number of chain inputs pulled to 1 is even, then expect 1 at the output. If the number of chain inputs pulled to 1 is odd, expect 0 at the output.

Continuing with the example in [Table 24-1](#), as the input pins are driven to 1 across the chain in sequence, the XOR Output will toggle between 0 and 1. Any break in the toggling sequence (e.g., "1011") will identify the location of the short or open.

24.2 XOR Chain Tables

Table 24-2. XOR Chain #1 (REQ[4:1]# = 0000)

Pin Name	Ball #	Notes
ACZ_SYNC	B9	Top of XOR Chain
ACZ_BIT_CLK	C10	2nd signal in XOR
ACZ_SDOUT	C9	
REQ[3]#	B8	
GNT[3]#	C8	
REQ[6]#/GPI[0]	B7	
PIRQ[F]#/GPI[3]	C7	
GNT[6]#/GPO[16]	D8	
GNT[1]#	B6	
REQ[1]#	B5	
PIRQ[G]#/GPI[4]	C6	
REQ[5]#/GPI[1]	E8	
AD[10]	A2	
PIRQ[E]#/GPI[2]	D9	
GNT[4]#/GPO[48]	E7	
AD[24]	B3	
AD[26]	B2	
AD[1]	E5	
AD[9]	D3	
GNT[5]#/GPO[17]	F6	
AD[5]	E9	
AD[18]	D4	
REQ[4]#/GPI[40]	F7	
AD[2]	C2	
AD[3]	F5	
GNT[0]#	C1	
AD[11]	D2	
PAR	E1	
AD[0]	E2	

Pin Name	Ball #	Notes
SERR#	G5	30 th signal in XOR
AD[4]	F3	
AD[6]	F2	
C/BE[1]#	H6	
AD[20]	G3	
GNT[2]#	F1	
C/BE[0]#	J6	
AD[15]	J5	
AD[13]	H3	
AD[22]	H2	
FRAME#	J3	
TRDY#	J2	
STOP#	J1	
AD[28]	K3	
REQ[0]#	L5	
AD[16]	K2	
PIRQ[D]#	L3	
PIRQ[B]#	L2	
AD[30]	L1	
REQ[2]#	M5	
PIRQ[H]#/GPI[5]	M3	
PIRQ[C]#	M1	
PIRQ[A]#	N2	
PLTRST#	R5	
ACZ_SDIN[0]	F11	
ACZ_RST#	A10	
ACZ_SDIN[2]	B10	
ACZ_SDIN[1]	F10	
BATLOW#/TP[0]	V2	XOR Chain #1 OUTPUT

Table 24-3. XOR Chain #2 (REQ[4:1]# = 0001)

Pin Name	Ball #	Notes	Pin Name	Ball #	Notes
AD[29]	A5	Top of XOR Chain	GPI[8]	R1	27th signal in XOR
IRDY#	A3	2nd signal in XOR	RI#	T2	
AD[14]	B4		PWRBTN#	U1	
AD[7]	D6		TP[3]	U3	
PLOCK#	C5		BATLOW#/TP[0]	V2	
AD[12]	D5		SATARBIAS#	AG11	
AD[8]	E6		SATARBIAS	AF11	
DEVSEL#	C3		SATA[0]RXN	AE3	
PERR#	E3		SATA[0]RXP	AD3	
PCICLK	G6		SATA[0]TXN	AG2	
C/BE[2]#	G4		SATA[0]TXP	AF2	
AD[23]	H5		SATA[1]RXN/ RESERVED	AC5	
AD[21]	H4		SATA[1]RXP/ RESERVED	AD5	
C/BE[3]#	G2		SATA[1]TXN/ RESERVED	AF4	
AD[27]	K6		SATA[1]TXP/ RESERVED	AG4	
AD[17]	K5		BMBUSY#/ GPI[6]	AD19	
AD[31]	K4		SATA[1]GP/ GPI[29]	AE18	
AD[19]	L6		GPI[7]	AE19	
AD[25]	M6		SATA[0]GP/ GPI[26]	AF17	
LAD[0]/FWH[0]	P2		CLKRUN#/ GPIO[32]	AF19	
LAD[1]/FWH[1]	N3		GPIO[33]	AF20	
LAD[2]/FWH[2]	N5		GPIO[34]	AC18	
LAD[3]/FWH[3]	N4		GPO[21]	AD20	
LDRQ[0]#	N6		THRM#	AC20	
LFRAME#/ FWH[4]	P3		MCH_SYNC#	AG21	
LDRQ[1]#/GPI[41]	P4				
			REQ[6]#/GPI[0]	B7	XOR Chain #2 OUTPUT

Table 24-4. XOR Chain #3 (REQ[4:1]# = 0010)

Pin Name	Ball #	Notes
INTRUDER#	AA3	Top of XOR Chain
INTVRMEN	AA5	2nd signal in XOR
DD[6]	AD11	
DD[10]	AB12	
DD[3]	AD12	
DD[7]	AB11	
DD[12]	AC13	
DD[8]	AE13	
DD[15]	AD13	
DD[5]	AC11	
DD[9]	AF13	
DD[4]	AE14	
DD[0]	AD14	
DIOW#	AC14	
DD[2]	AF14	
DD[14]	AG15	
DDACK#	AB15	
DD[11]	AB13	
DD[13]	AE15	
DDREQ	AB14	
DD[1]	AF15	
IORDY	AF16	
DIOR#	AE16	
DCS1#	AD16	

Pin Name	Ball #	Notes
DA[0]	AC16	25th signal in XOR
DCS3#	AE17	
IDEIRQ	AB16	
DA[2]	AC17	
DA[1]	AB17	
DPRSLPVR/ TP[1]	AE20	
VRMPWRGD	AF21	
INIT3_3V#	AE22	
GPO[23]	AD21	
GPO[19]	AB21	
STP_PCI#/ GPO[18]	AC21	
STP_CPU#/ GPO[20]	AD22	
A20GATE	AF22	
RCIN#	AD23	
A20M#	AF23	
INTR	AG24	
DPRSTP#/TP[4]	AE24	
CPUPWRGD/ GPO[49]	AG25	
NMI	AF25	
INIT#	AF27	
CPUSLP#	AE27	
STPCLK#	AE26	
THRMTRIP#	AE23	
DPSLP#/TP[2]	AD27	
RI#	T2	XOR Chain #3 OUTPUT

Table 24-5. XOR Chain #4-1 (REQ[4:1]# = 0011)

Pin Name	Ball #	Notes	Pin Name	Ball #	Notes
DMI[3]RXN	AB24	Top of XOR Chain	OC[4]#/GPI[9]	C23	22nd signal in XOR
DMI[3]RXP	AB23	2nd signal in XOR	OC[7]#/GPI[15]	C24	
DMI[3]TXP	AA26		OC[6]#/GPI[14]	C25	
DMI[3]TXN	AA27		CLK48	A27	
DMI[2]RXN	Y25		USBP[0]N	C21	
DMI[2]RXP	Y24		USBP[0]P	D21	
DMI[2]TXP	W26		USBP[1]N	A20	
DMI[2]TXN	W27		USBP[1]P	B20	
PERn[4]	P24		USBP[2]N	D19	
PERp[4]	P23		USBP[2]P	C19	
PETp[4]	N26		USBP[3]N	A18	
PETn[4]	N27		USBP[3]P	B18	
PERn[3]	M25		USBP[4]N	E17	
PERp[3]	M24		USBP[4]P	D17	
PETp[3]	L26		USBP[5]N	B16	
PETn[3]	L27		USBP[5]P	A16	
OC[0]#	C27		USBP[6]N	C15	
OC[2]#	B26		USBP[6]P	D15	
OC[1]#	B27		USBP[7]N	A14	
OC[5]#/GPI[10]	D23		USBP[7]P	B14	
OC[3]#	C26				
			GPI[8]	R1	XOR Chain #4-1 OUTPUT

Table 24-6. XOR Chain #4-2 (REQ[4:1]# = 0011)

Pin Name	Ball #	Notes
LAN_RXD[2]	C13	Top of XOR Chain
EE_SHCLK	B12	2nd signal in XOR
LAN_TXD[0]	C12	
LAN_TXD[2]	E13	
EE_CS	D12	
LAN_RSTSYNC	B11	
EE_DIN	F13	
LAN_RXD[0]	E12	
LAN_TXD[1]	C11	
EE_DOUT	D11	
LAN_RXD[1]	E11	
LAN_CLK	F12	
CLK14	E10	
SPKR	F8	
GPI[12]	M2	
GPIO[25]	P5	
PME#	P6	
PCIRST#	R2	
GPIO[27]	R3	
GPI[13]	R6	
GPIO[28]	T3	
SLP_S5#	T6	
SLP_S4#	T5	
SLP_S3#	T4	
WAKE#	U5	

Pin Name	Ball #	Notes
SMLINK[1]	U6	26th signal in XOR
SYS_RESET#	U2	
GPIO[24]	V3	
SUSCLK	V6	
SUS_STAT#/LPCPD#	W3	
SMLINK[0]	W4	
SMBDATA	W5	
SMBCLK	Y4	
SMBALERT#/GPI[11]	W6	
LINKALERT#	Y5	
SATA[2]RXN	AD7	
SATA[2]RXP	AC7	
SATA[2]TXN	AF6	
SATA[2]TXP	AG6	
SATA[3]RXN/RESERVED	AC9	
SATA[3]RXP/RESERVED	AD9	
SATA[3]TXN/RESERVED	AF8	
SATA[3]TXP/RESERVED	AG8	
SATA[3]GP/GPI[31]	AG18	
SATALED#	AC19	
SATA[2]GP/GPI[30]	AF18	
SERIRQ	AB20	
FERR#	AF24	
SMI#	AG27	
IGNNE#	AG26	
PLTRST#	R5	XOR Chain #4-2 OUTPUT

Table 24-7. XOR Chain #5 (REQ[4:1]# = 0100)

Pin Name	Ball #	Notes
DMI[1]RXN	V25	Top of XOR Chain
DMI[1]RXP	V24	2nd signal in XOR
DMI[1]TXP	U26	
DMI[1]TXN	U27	
DMI[0]RXN	T25	
DMI[0]RXP	T24	
DMI[0]TXP	R26	
DMI[0]TXN	R27	

Pin Name	Ball #	Notes
PERn[2]	K25	9th signal in XOR
PERp[2]	K24	
PETp[2]	J26	
PETn[2]	J27	
PERn[1]	H25	
PERp[1]	H24	
PETp[1]	G26	
PETn[1]	G27	
REQ[6]#/GPI[0]	B7	XOR Chain #5 OUTPUT

§