

NPN SILICON RF POWER TRANSISTOR

DESCRIPTION:

The **ASI ULBM5SL** is Designed for Class C, FM Land Mobile Applications up to 470 MHz.

FEATURES:

- Common Emitter
- $P_G = 8.5$ dB at 5.0 W/470 MHz
- **Omnigold™** Metalization System

MAXIMUM RATINGS

I_C	1.7 A
V_{CBO}	36 V
V_{CER}	16 V
V_{CES}	36 V
V_{EBO}	4.0 V
P_{DISS}	15 W @ $T_C = 25$ °C
T_J	-65 °C to +200 °C
T_{STG}	-65 °C to +150 °C
θ_{JC}	12 °C/W

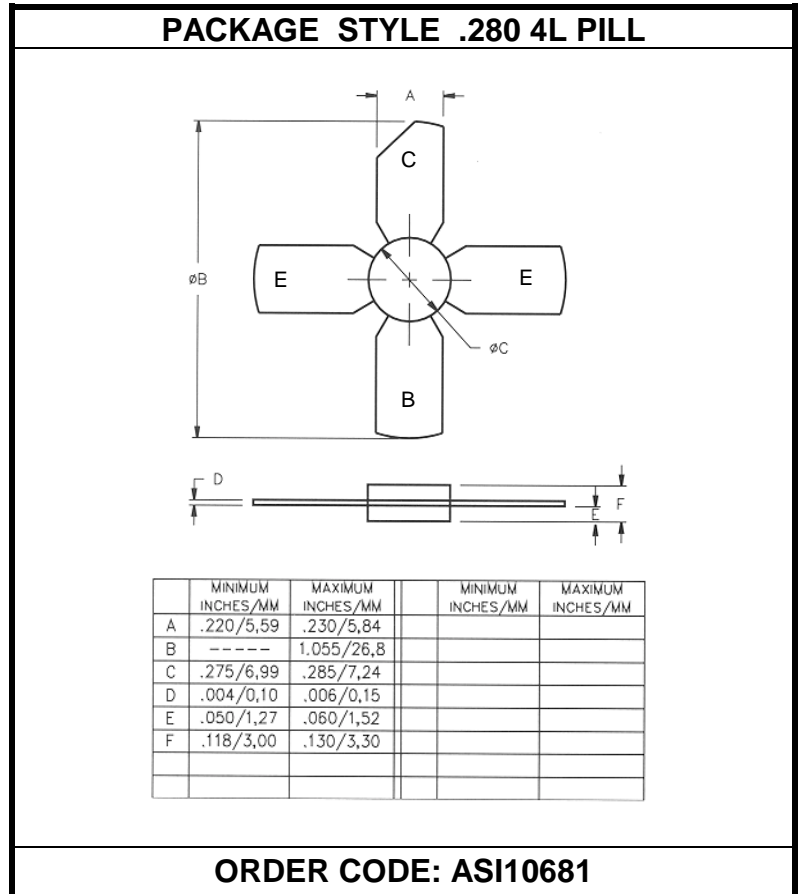
CHARACTERISTICS $T_C = 25$ °C

SYMBOL	TEST CONDITIONS	MINIMUM	TYPICAL	MAXIMUM	UNITS
BV_{CEO}	$I_C = 50$ mA	16			V
BV_{CES}	$I_C = 10$ mA	36			V
BV_{EBO}	$I_E = 2.0$ mA	4.0			V
I_{CER}	$V_{CE} = 10$ V $R_{BE} = 50$ Ω			0.5	mA
I_{CBO}	$V_{CB} = 15$ V			1.0	mA
h_{FE}	$V_{CE} = 5.0$ V $I_C = 1.0$ A	10		100	---
C_{ob}	$V_{CB} = 7.5$ V $f = 1.0$ MHz			22	pF
P_G η_c	$V_{CC} = 7.5$ V $P_{OUT} = 5.0$ W $f = 470$ MHz	8.5	60		dB %

TYPICAL IMPEDANCE DATA:

FREQUENCY (MHz)	Z_{IN} (Ω)	Z_{CL} (Ω)
400	$1.2 + j0.6$	$6.9 - j6.5$
440	$1.2 + j0.9$	$7.2 - j6.0$
470	$1.2 + j1.2$	$7.7 - j5.3$
512	$1.2 + j1.5$	$8.3 - j4.5$

Conditions: $V_{CC} = 12.5$ V, $P_{OUT} = 5.0$ W

TEST CIRCUIT

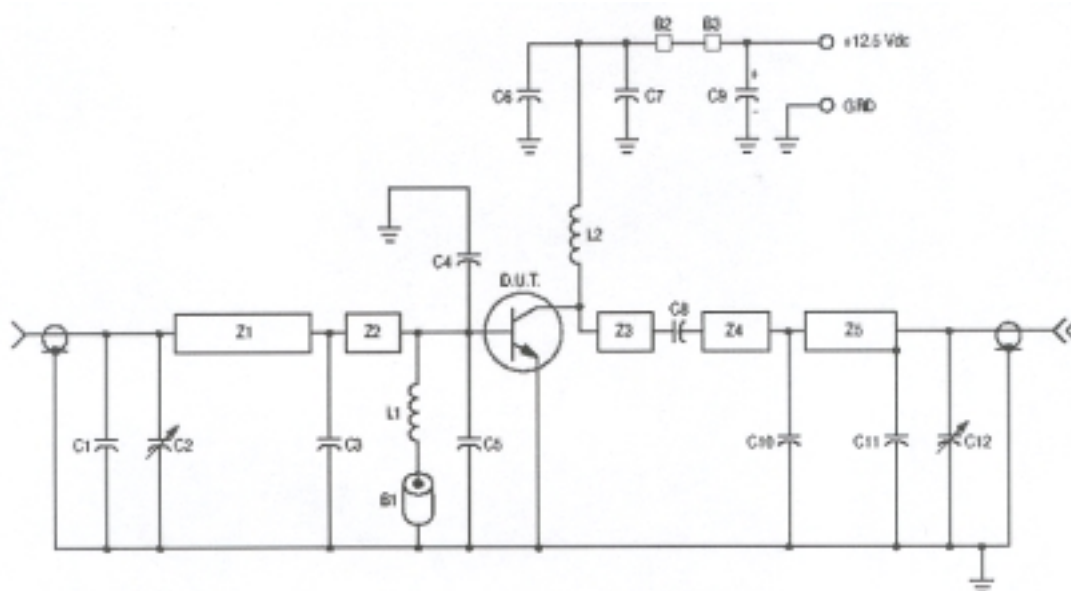

- | | |
|--|--|
| B1, B2, B3 – Ferrite Bead | C8 – 68 pF Mini-Underwood Mica |
| C1 – 7.0 pF Unelco Mica | C9 – 1.0 μ F Electrolytic 25 V |
| C2 – 1.0-6.0 pF Johanson Variable 5201 | C10, C11 – 5.0 pF Unelco Mica |
| C3 – 15 pF Unelco Mica | C12 – 1.0-10 pF Johanson Variable 5501 |
| C4 – 43 pF Mini-Underwood Mica | L1, L2 – 6 Turns, 20 AWG Wire 0.125" ID |
| C5 – 56 Mini-Underwood Mica | Z1, Z2 – 25 Ω μ Stripline |
| C6 – 1000 pF Unelco Mica | Z3, Z4, Z5 – 50 Ω μ Stripline |
| C7 – 0.1 pF Ceramic | Board – 0.032" Glass-Teflon |

440-512 MHz Broadband Test Circuit