

# ATS610LSC

## *DYNAMIC, PEAK-DETECTING, DIFFERENTIAL HALL-EFFECT GEAR-TOOTH SENSOR*

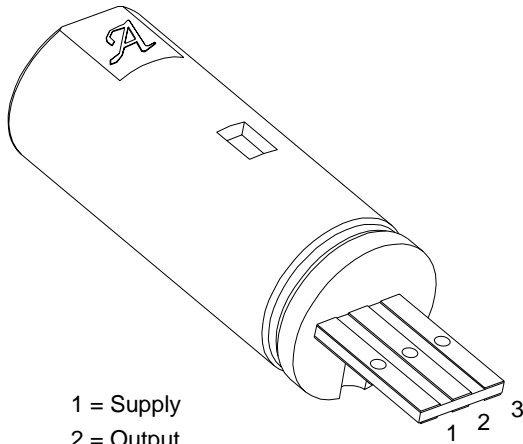

1 = Supply  
2 = Output  
3 = Ground

Dwg. AH-008

**PRELIMINARY INFORMATION**  
(subject to change without notice)  
September 3, 1998

### **ABSOLUTE MAXIMUM RATINGS** over operating temperature range

Supply Voltage, $V_{CC}$ .....	24 V
Reverse Supply Voltage, $V_{RCC}$ (1 minute max.) .....	-24 V
Output OFF Voltage, $V_{OUT}$ .....	18 V
Reverse Output Voltage, $V_{OUT}$ .....	-0.5 V
Continuous Output Current, $I_{OUT}$ .....	25 mA
Package Power Dissipation, $P_D$ .....	See Graph
Operating Temperature Range, $T_A$ .....	-40°C to +150°C
Storage Temperature, $T_S$ .....	+170°C

The ATS610LSC gear-tooth sensor is an optimized Hall IC plus magnet subassembly that provides a user-friendly solution for digital gear-tooth sensing applications. The subassembly combines in a compact high-temperature plastic shell, a samarium-cobalt magnet, a pole piece, a differential Hall-effect IC that has been optimized to the magnetic circuit, and a voltage regulator. The sensor can be easily used in conjunction with a wide variety of gear or target shapes and sizes.

The ATS610LSC is designed to provide increased immunity to false switching in applications that require the sensing of large-tooth gears (e.g., crank angle or cam angle). The sensor subassembly is ideal for use in gathering speed, position, and timing information using gear-tooth-based configurations.

The gear-sensing technology used for this sensor plus magnet subassembly is Hall-effect based. The sensor incorporates a dual-element Hall IC that switches in response to differential magnetic signals created by the ferrous target. The circuitry contains a patented track-and-hold peak-detecting circuit to eliminate magnet and system offset effects. This circuit has the ability to detect relatively fast changes, such as those caused by gear wobble and eccentricities, and provides stable operation at extremely low rotation speeds.

### **FEATURES AND BENEFITS**

- Fully Optimized Differential Digital Gear-Tooth Sensor
- Single-Chip Sensing IC for High Reliability
- Extremely Low Timing Accuracy Drift with Temperature
- Large Operating Air Gaps
- Small Mechanical Size
- Optimized Magnetic Circuit
- Patented Peak-Detecting Filter:
  - <200  $\mu$ s Power-On Time
  - <10 RPM Operation (single-tooth target)
  - Correct First-Edge Detection
- Under-Voltage Lockout
- Wide Operating Voltage Range
- Defined Power-Up State

Always order by complete part number: **ATS610LSC** .

# ATS610LSC

## DYNAMIC, PEAK-DETECTING, DIFFERENTIAL HALL-EFFECT GEAR-TOOTH SENSOR

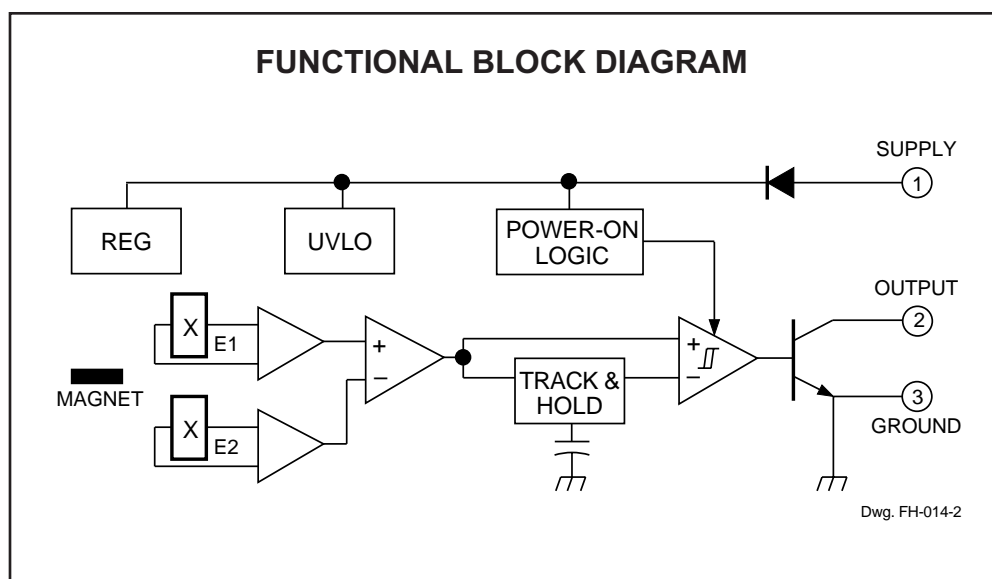
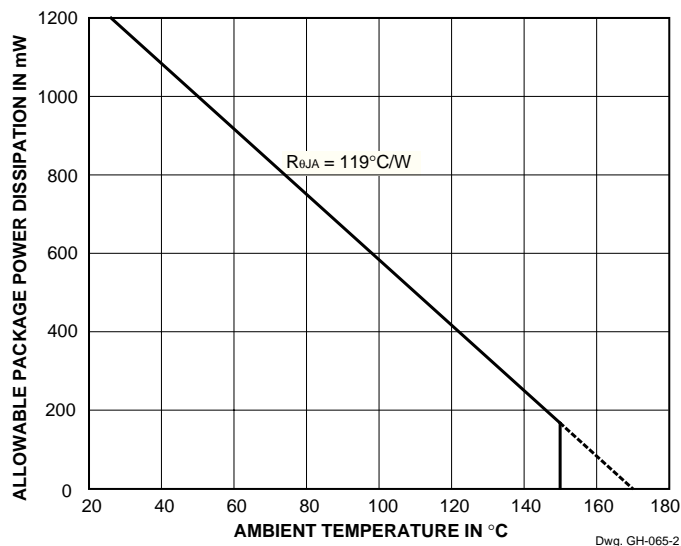

**ATS610LSC**  
**DYNAMIC, PEAK-DETECTING,**  
**DIFFERENTIAL HALL-EFFECT**  
**GEAR-TOOTH SENSOR**

**ELECTRICAL CHARACTERISTICS over operating voltage and temperature range.**

Characteristic	Symbol	Test Conditions	Limits			
			Min.	Typ.	Max.	Units
Supply Voltage	$V_{CC}$	Operating, $T_J < 165^\circ\text{C}$	5.0	12	24	V
Power-On State	POS	$V_{CC} = 0 \rightarrow 5\text{ V}$	HIGH	HIGH	HIGH	–
Under-Voltage Lockout	$V_{CC(UV)}$	$I_{OUT} = 20\text{ mA}$ , $V_{CC} = 0 \rightarrow 5\text{ V}$	–	4.0	–	V
Output Saturation Voltage	$V_{OUT(SAT)}$	$I_{OUT} = 20\text{ mA}$	–	350	600	mV
Output Leakage Current	$I_{OFF}$	$V_{OUT} = 18\text{ V}$ , Output OFF	–	5.0	15	$\mu\text{A}$
Supply Current	$I_{CC}$	$V_{CC} = 6\text{ V}$ , Output OFF	5.5	7.7	11	mA
		$V_{CC} = 6\text{ V}$ , Output ON	8.5	10.5	13	mA
Power-On Delay	$t_{on}$		–	–	200	$\mu\text{s}$
Output Rise Time	$t_r$	$R_L = 500\ \Omega$ , $C_L = 10\text{ pF}$	–	0.2	2.0	$\mu\text{s}$
Output Fall Time	$t_f$	$R_L = 500\ \Omega$ , $C_L = 10\text{ pF}$	–	0.2	2.0	$\mu\text{s}$

NOTE: Typical data is at  $V_{CC} = 12\text{ V}$  and  $T_A = +25^\circ\text{C}$  and is for design information only.

**OPERATION over operating voltage and temperature range with reference target (unless otherwise specified).**

Characteristic	Symbol	Test Conditions	Limits			
			Min.	Typ.	Max.	Units
Air Gap Range	AG	Operating, Target Speed > 20 RPM	0.4	–	1.5	mm
Minimum Air Gap	$AG_{min}$	Operating, One-Tooth ( $180^\circ$ ) Target, Target Speed = 1000 RPM	–	0.25	–	mm
Maximum Air Gap	$AG_{max}$	Operating, One-Tooth ( $180^\circ$ ) Target, Target Speed = 1000 RPM	–	2.25	–	mm
Timing Accuracy	$t_\theta$	Target Speed = 1000 RPM, $0.4\text{ mm} \leq AG \leq 1.5\text{ mm}$	–	$\pm 0.5$	$\pm 1.0$	$^\circ$

NOTE: Air Gap is defined as the distance from the face of the sensor subassembly to the target.

**ATS610LSC**  
**DYNAMIC, PEAK-DETECTING,**  
**DIFFERENTIAL HALL-EFFECT**  
**GEAR-TOOTH SENSOR**

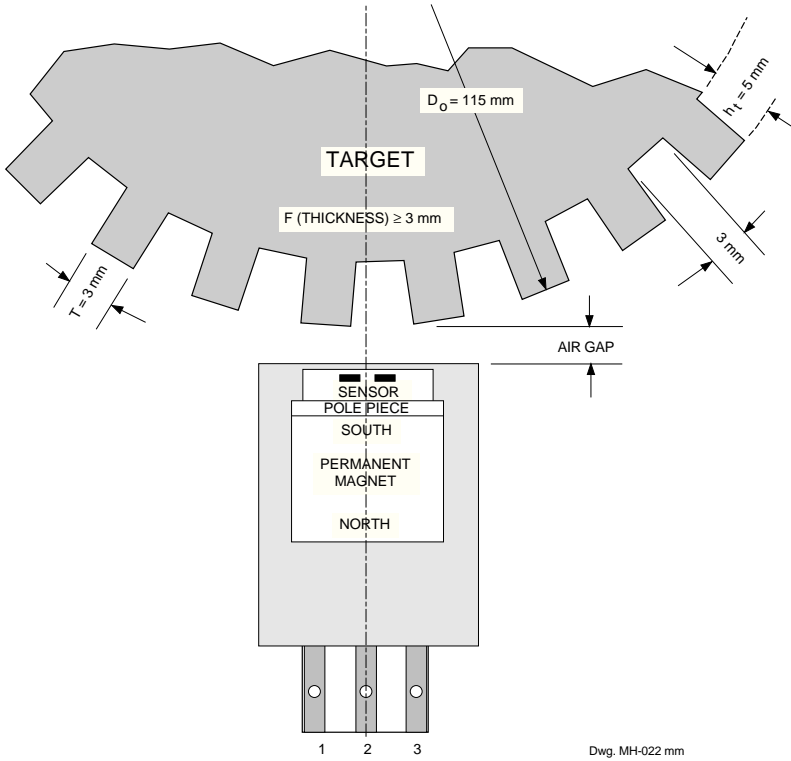

**REFERENCE TARGET**

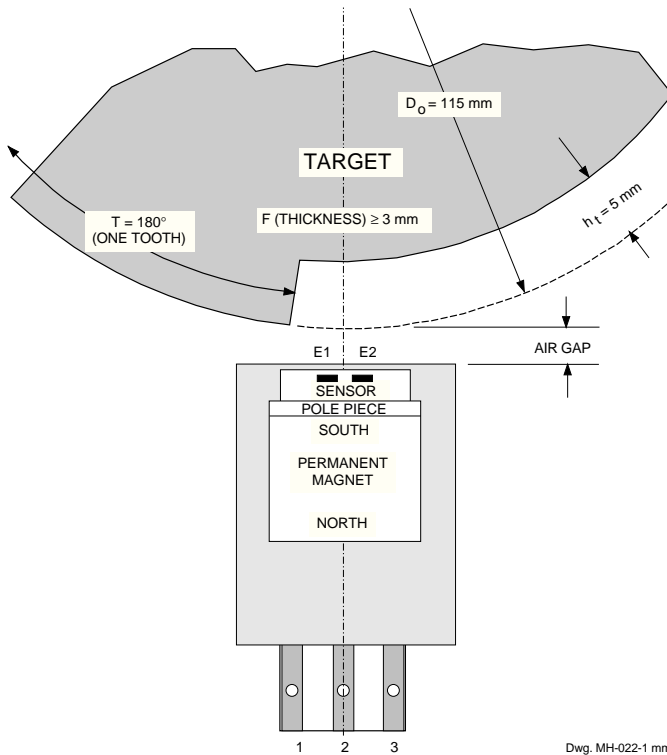

**ONE-TOOTH (180°) TARGET**

# ATS610LSC

## DYNAMIC, PEAK-DETECTING, DIFFERENTIAL HALL-EFFECT GEAR-TOOTH SENSOR

### TYPICAL ATS610LSC ELECTRICAL CHARACTERISTICS

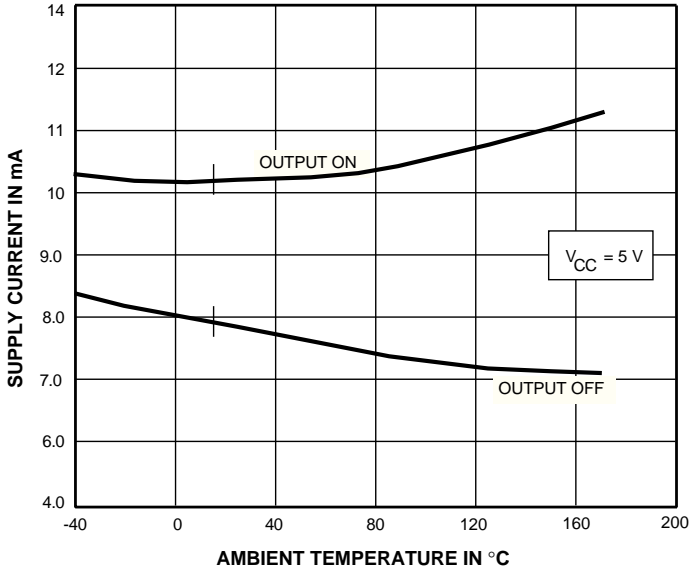

Dwg. GH-014-1

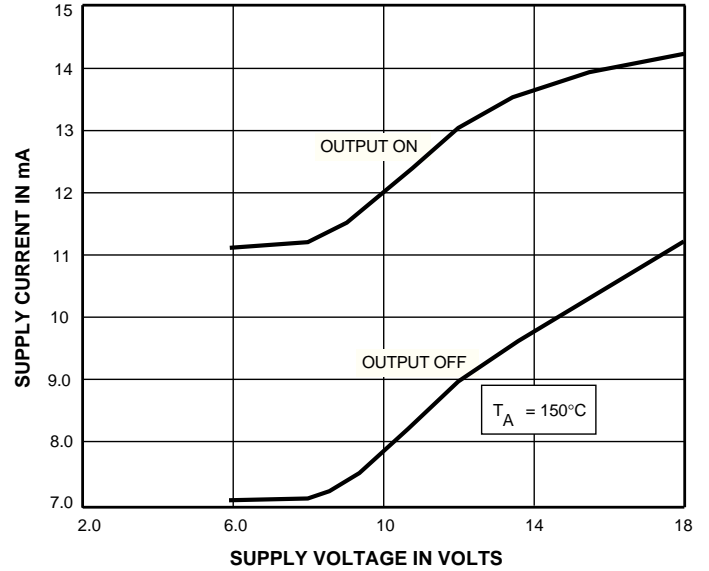

Dwg. GH-058-2

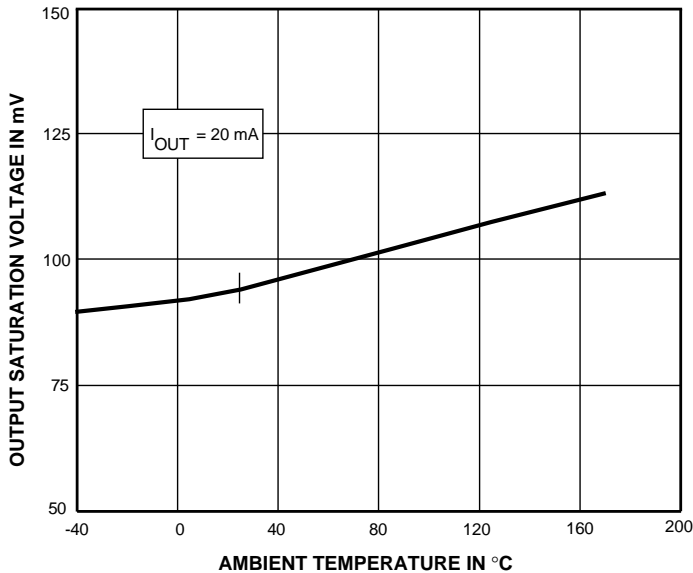

Dwg. GH-013-1

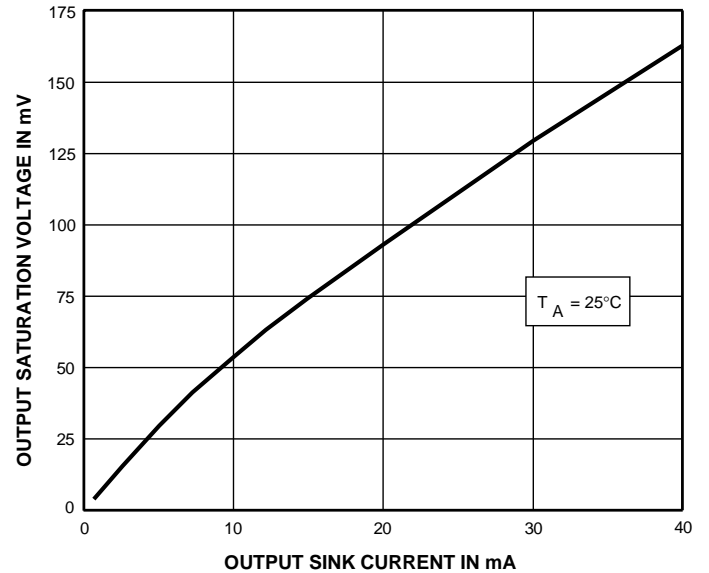

Dwg. GH-059

continued next page...

# ATS610LSC DYNAMIC, PEAK-DETECTING, DIFFERENTIAL HALL-EFFECT GEAR-TOOTH SENSOR

## TYPICAL ATS610LSC OPERATING CHARACTERISTICS (with reference target)

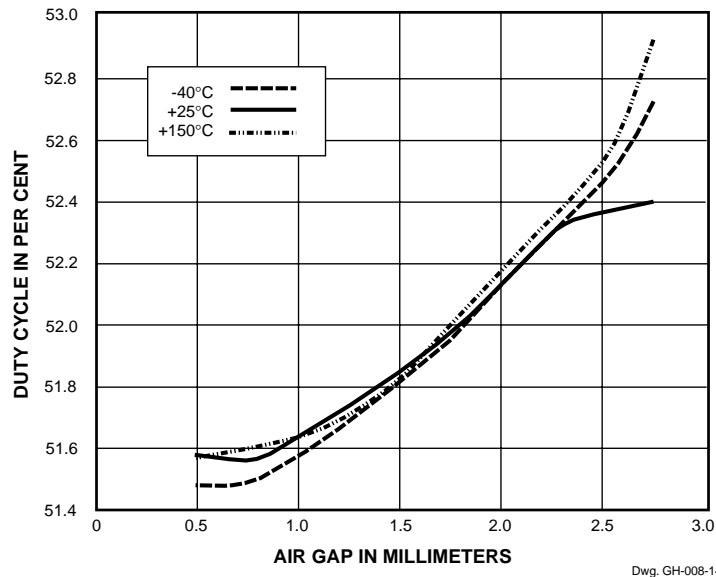
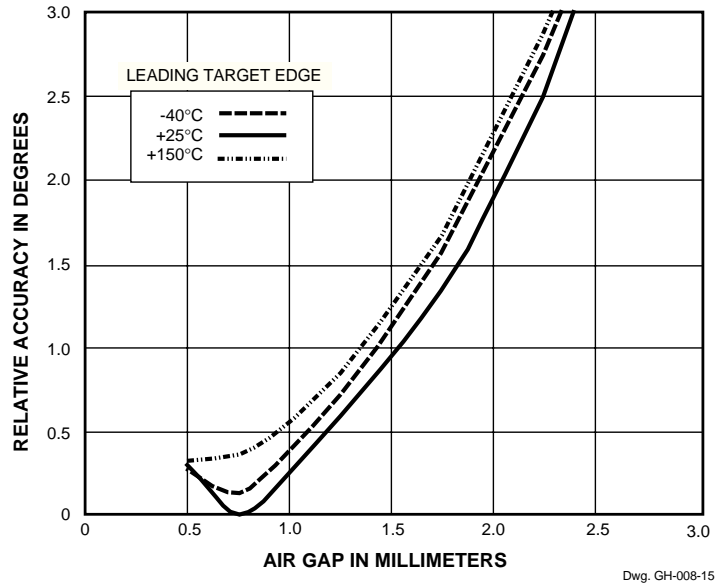
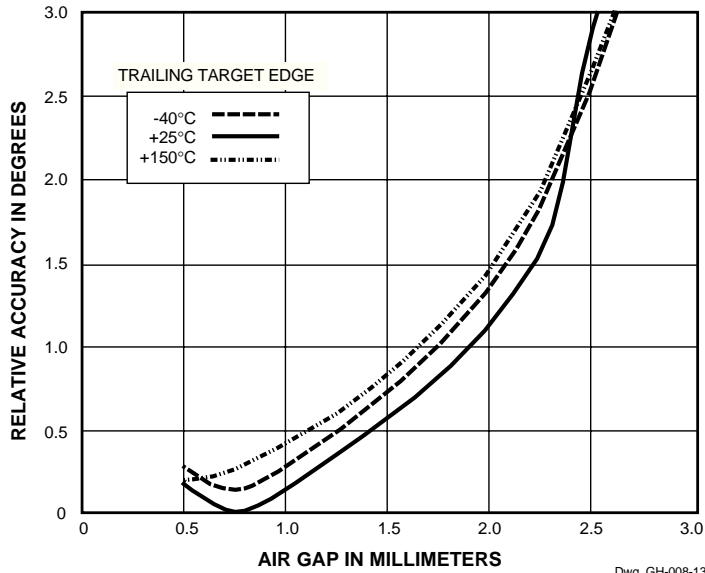

continued next page...

# ATS610LSC DYNAMIC, PEAK-DETECTING, DIFFERENTIAL HALL-EFFECT GEAR-TOOTH SENSOR

## TYPICAL ATS610LSC OPERATING CHARACTERISTICS (with reference target) — Continued

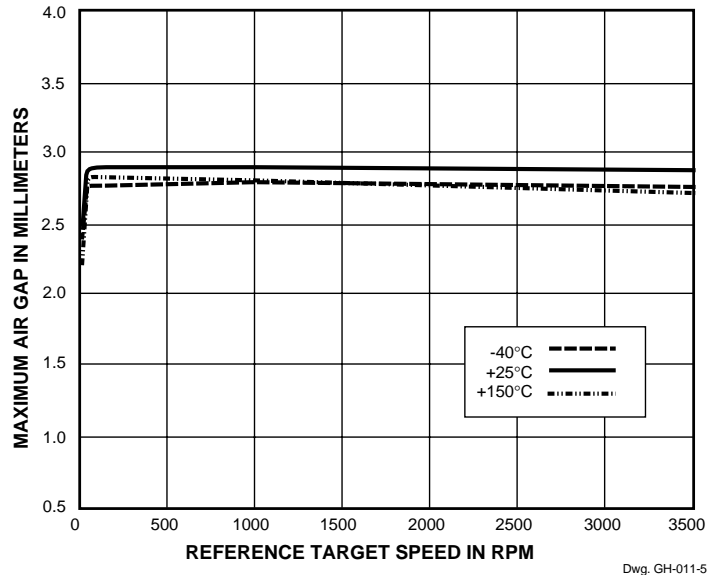
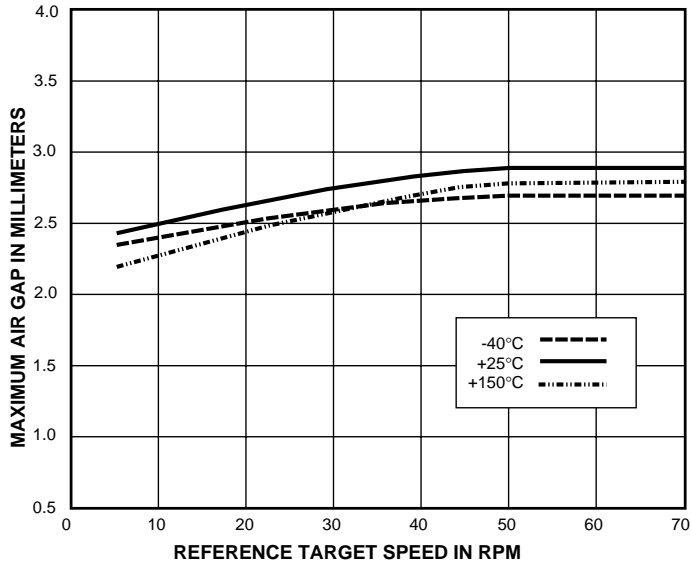

## DEVICE DESCRIPTION

The ATS610LSC dynamic, peak-detecting, differential Hall-effect gear-tooth sensor is a Hall IC plus magnet subassembly that is fully optimized to provide digital detection of gear-tooth edges in a small package size. The sensor is packaged in a miniature plastic housing that has been optimized for size, ease of assembly, and manufacturability. High operating temperature materials are used in all aspects of construction.

The application of this sensor is uncomplicated. After power is applied to the device, it is capable of quickly providing digital information that is representative of a rotating gear or specially designed target. No additional optimization or processing circuitry is required. This ease of use should reduce design time and incremental assembly costs for most applications.

**Sensing Technology.** The gear-tooth sensor subassembly contains a single-chip differential Hall-effect sensor IC, a samarium-cobalt magnet, and a flat ferrous pole piece. The Hall IC consists of two Hall elements spaced 2.235

mm (0.088") apart, which senses the magnetic gradient created by the passing of a ferrous object (a gear tooth). The two Hall voltages are compared and the difference is then processed to provide a digital output signal.

The processing circuit uses a patented peak-detection technique to eliminate magnet and system offsets. This technique allows coupling and filtering of offsets without the power-up and settling time disadvantages of classical high-pass filtering schemes. Here, the peak signal of every tooth and valley is detected and is used to provide an instant reference for the operate-point and release-point comparators. In this manner, the thresholds are adapted and referenced to individual signal peaks and valleys, thereby providing immunity to zero-line variation due to installation inaccuracies (tilt, rotation, and off-center placement), as well as for variations caused by target and shaft eccentricities. The peak detection concept also allows extremely low-speed operation when used with small-value capacitors.

# ATS610LSC DYNAMIC, PEAK-DETECTING, DIFFERENTIAL HALL-EFFECT GEAR-TOOTH SENSOR

## DEVICE DESCRIPTION — Continued

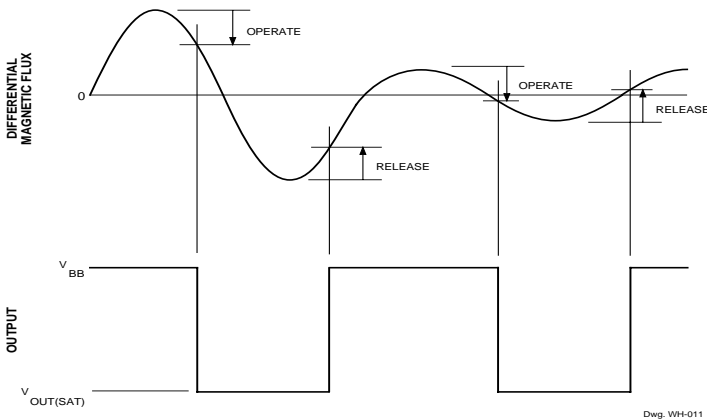

**Power-On Operation.** The device will power on in the OFF state (output high) irrespective of the magnetic field condition. The power-on time of the circuit is no greater than 5000  $\mu$ s. The circuit is then ready to accurately detect the first target edge that results in a HIGH-to-LOW transition.

**Under-Voltage Lockout.** When the supply voltage is below the minimum operating voltage ( $V_{CC(UV)}$ ), the device is OFF and stays OFF irrespective of the state of the magnetic field. This prevents false signals, which may be caused by under-voltage conditions (especially during turn on), from appearing at the output.

**Output.** The device output is an open-collector stage capable of sinking 25 mA. An external pull-up (resistor) to a supply voltage of not more than 18 V must be supplied.

**Superior Performance.** The ATS610LSC peak-detecting differential gear-tooth sensor sub-assembly has several advantages over conventional Hall-effect gear-tooth sensors.

**Differential vs. Single-Element Sensing.** The differential Hall-element configuration is superior in most applications to the classical single-element gear-tooth sensor. The single-element configuration commonly used (Hall-effect sensor mounted on the face of a simple permanent magnet) requires the detection of a small signal (often <100 G) that is superimposed on a large back-biased field, often 1500 G to 3500 G. For most gear/target configurations, the back-biased field values

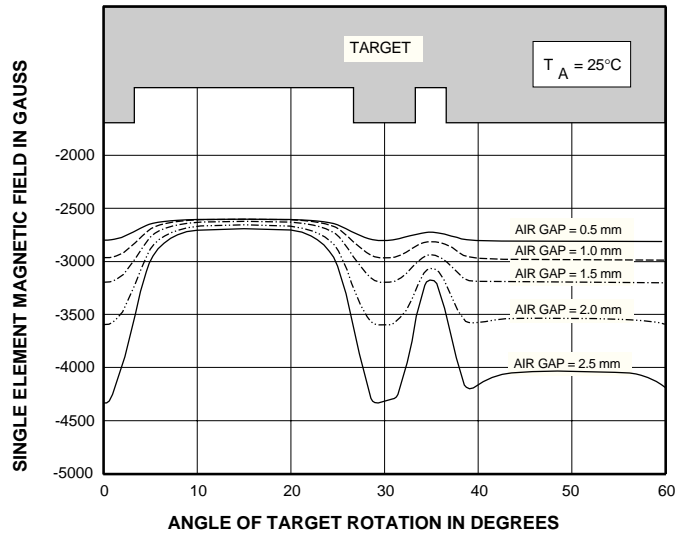

Single-element flux maps showing the impact of varying valley widths

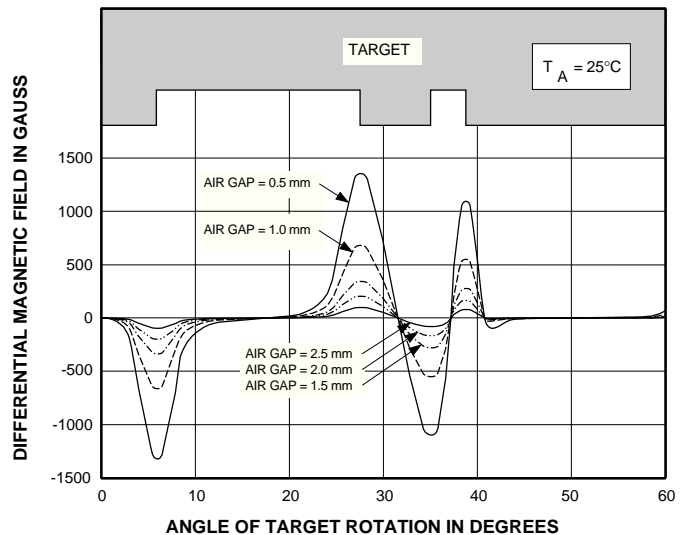

Differential flux maps vs. air gaps

change due to concentration effects, resulting in a varying baseline with air gap, with valley widths, with eccentricities, and with vibration. The differential configuration cancels the effects of the back-biased field and avoids many of the issues presented by the single Hall element.

NOTE — 10 G = 1 mT, exactly.



# ATS610LSC

## *DYNAMIC, PEAK-DETECTING, DIFFERENTIAL HALL-EFFECT GEAR-TOOTH SENSOR*

### DEVICE DESCRIPTION — Continued

**Peak-Detecting vs. AC-Coupled Filters.** High-pass filtering (normal ac coupling) is a commonly used technique for eliminating circuit offsets. AC coupling has errors at power up because the filter circuit needs to hold the circuit zero value even though the circuit may power up over a large signal. Such filter techniques can only perform properly after the filter has been allowed to settle, which is typically greater than one second. Also, high-pass filter solutions cannot easily track rapidly changing baselines such as those caused by eccentricities. Peak detection switches on the change in slope of the signal and is baseline independent at power up and during running.

**Track-and-Hold Peak Detecting vs. Zero-Crossing Reference.** The usual differential zero-crossing sensors are susceptible to false switching due to off-center and tilted installations, which result in a shift in baseline that changes with air gap. The track-and-hold peak-detection technique ignores baseline shifts versus air gaps and provides increased immunity to false switching. In addition, using track-and-hold peak-detecting techniques, increased air gap capabilities can be expected because a peak detector utilizes the entire peak-to-peak signal range as compared to zero-crossing detectors that switch on fixed thresholds.

NOTE — “Baseline” refers to the zero-gauss differential where each Hall-effect element is subject to the same magnetic field strength.

### CRITERIA FOR DEVICE QUALIFICATION

All Allegro sensors are subjected to stringent qualification requirements prior to being released to production. To become qualified, except for the destructive ESD tests, no failures are permitted.

Qualification Test	Test Method and Test Conditions	Test Length	Samples Per Lot	Comments
Temperature Humidity Bias Life	JESD22-A101, T <sub>A</sub> = 85°C, RH = 85%	1000 hrs	48	Device biased for minimum power
Bias Life (Surge Operating Life)	JESD22-A108, T <sub>A</sub> = 150°C, T <sub>J</sub> = 165°C	1000 hrs	48	
	JESD22-A108, T <sub>A</sub> = 175°C, T <sub>J</sub> = 190°C	168 hrs	48	
Autoclave, Unbiased	JESD22-A102, T <sub>A</sub> = 121°C, 15 psig	96 hrs	48	
High-Temperature (Bake) Storage Life	JESD22-A103, T <sub>A</sub> = 170°C	1000 hrs	48	
Temperature Cycle	JESD22-A104	1000 cycles	60	-55°C to +150°C
ESD, Human Body Model	CDF-AEC-Q100-002	Pre/Post Reading	3 per test	Test to failure All leads > 8 kV

# ATS610LSC DYNAMIC, PEAK-DETECTING, DIFFERENTIAL HALL-EFFECT GEAR-TOOTH SENSOR

## APPLICATIONS INFORMATION

**Gear Diameter and Pitch.** Signal frequency is a direct function of gear pitch and rotational speed (RPM). The width of the magnetic signal in degrees and, hence, the signal slope created by the tooth is directly proportional to the circumference of the gear ( $\pi D_0$ ). Smaller diameters limit the low-speed operation due to the slower rate of change of the magnetic signal per degree of gear rotation (here the limitation is the droop of the capacitor versus the signal change). Larger diameters limit high-speed operation due to the higher rate of change of magnetic signal per degree of rotation (here the limitation is the maximum charge rate of the capacitor versus the rate of signal change). These devices are optimized for a 50 mm gear diameter (signal not limited by tooth width) and speeds of 10 RPM to 8000 RPM.

NOTE — In application, the terms “gear” and “target” are often interchanged. However, “gear” is preferred when motion is transferred.

**Air Gap and Tooth Geometry.** Operating specifications are impacted by tooth width (T), valley width ( $p_C - T$ ) and depth ( $h_t$ ), gear material, and gear face thickness (F). The target can be a gear or a specially cut shaft-mounted tone wheel made of stamped ferrous metal. In general, the following gear or target guidelines must be followed to achieve greater than 2 mm air gap from the face of unit:

- Tooth width, T ..... >2 mm
- Valley width,  $p_C - T$  ..... >2 mm
- (Whole) depth,  $h_t$  ..... >3 mm
- Gear material ..... low-carbon steel
- Gear face width (thickness), F .... >3 mm

Deviation from these guidelines will result in a reduction of air gap and a deterioration in timing accuracy. For applications that require the sensing of large-tooth targets, the optimal sensor choice is the ATS610LSC. Its high switching thresholds provide increased immunity to false switching caused by magnetic overshoot and other non-uniformities in the gear or target.

**Operation with Fine-Pitch Gears.** For targets with a circular pitch of less than 4 mm, a performance improvement can be observed by rotating the front face of the sensor subassembly. This sensor rotation decreases the

effective sensor-to-sensor spacing and increases the capability of detecting fine tooth or valley configurations, provided that the Hall elements are not rotated beyond the width of the target.

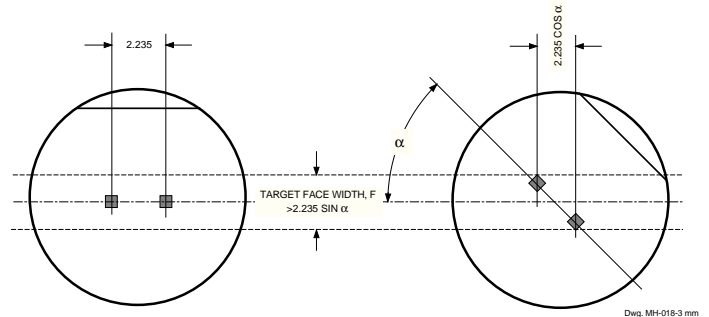

**Signal Timing Accuracy.** The magnetic field profile width is defined by the sensor element spacing and narrows in degrees as the target diameter increases. This results in improved timing accuracy performance for larger gear diameters (for the same number of gear teeth). The slope of this magnetic profile also changes with air gap, resulting in timing accuracy shift with air gap (refer to typical operating characteristic curves). Valley-to-tooth transitions will generally provide better accuracy than tooth-to-valley transitions for large-tooth or large-valley configurations. For highest accuracy, targets greater than 100 mm in diameter should be used.

**Signal Duty Cycle.** For repetitive target structures, precise duty cycle is maintained over the operating air gap and temperature range due to an extremely good symmetry in the magnetic switch points of the device. For nonrepetitive target structures, there will be a small but measureable change in pulse width versus air gap.

**Output Polarity.** The output of the device will switch from HIGH to LOW as the leading edge of the target passes the subassembly from terminal 3 to terminal 1, which means that the output will be LOW when the unit is facing a tooth. If rotation is in the opposite direction (terminal 1 to terminal 3), the output of the device will switch from LOW to HIGH as the leading edge of the target passes the subassembly, which means that the output will be HIGH when the unit is facing a tooth.

**ATS610LSC**  
**DYNAMIC, PEAK-DETECTING,**  
**DIFFERENTIAL HALL-EFFECT**  
**GEAR-TOOTH SENSOR**

**APPLICATIONS INFORMATION — Continued**

**Power Supply Protection and Operation From an Unregulated Power Supply.** The internal voltage regulator provides immunity to power supply variations between 5 V and 24 V. In automotive applications, where the device receives its power from an unregulated supply such as the battery, full protection is provided by the internal regulator circuit.

Additional applications Information on gear-tooth and other Hall-effect sensors is provided in the Allegro Integrated and Discrete Semiconductors Data Book or Application Note 27701.

**MECHANICAL INFORMATION**

Component	Material	Function	Units
Package	Polyamide 6/12, 33% glass filled	264 psi deflection temp. (DTUL) Approximate melting temperature	200°C 219°C
Circuit Board	High-temperature FR-4	Glass transition temperature	170°C
Terminals	1 oz Copper	–	–
Terminal Finish	63/37 tin/lead solder plate	–	†
Flame Class Rating	–	–	UL94V-0

† All industry-accepted soldering techniques are permitted for these subassemblies provided the indicated maximum temperature for each component (e.g., sensor face, plastic housing) is not exceeded. Reasonable dwell times, which do not cause melting of the plastic housing, should be used.

**Sensor Location (in millimeters)**  
(sensor location relative to package center is the design objective)

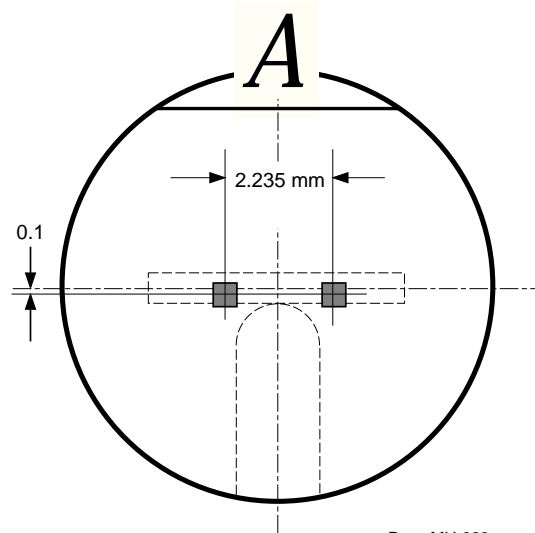

Dwg. MH-023 mm

**ATS610LSC**  
**DYNAMIC, PEAK-DETECTING,**  
**DIFFERENTIAL HALL-EFFECT**  
**GEAR-TOOTH SENSOR**

**ATS610LSC DIMENSIONS IN MILLIMETERS**

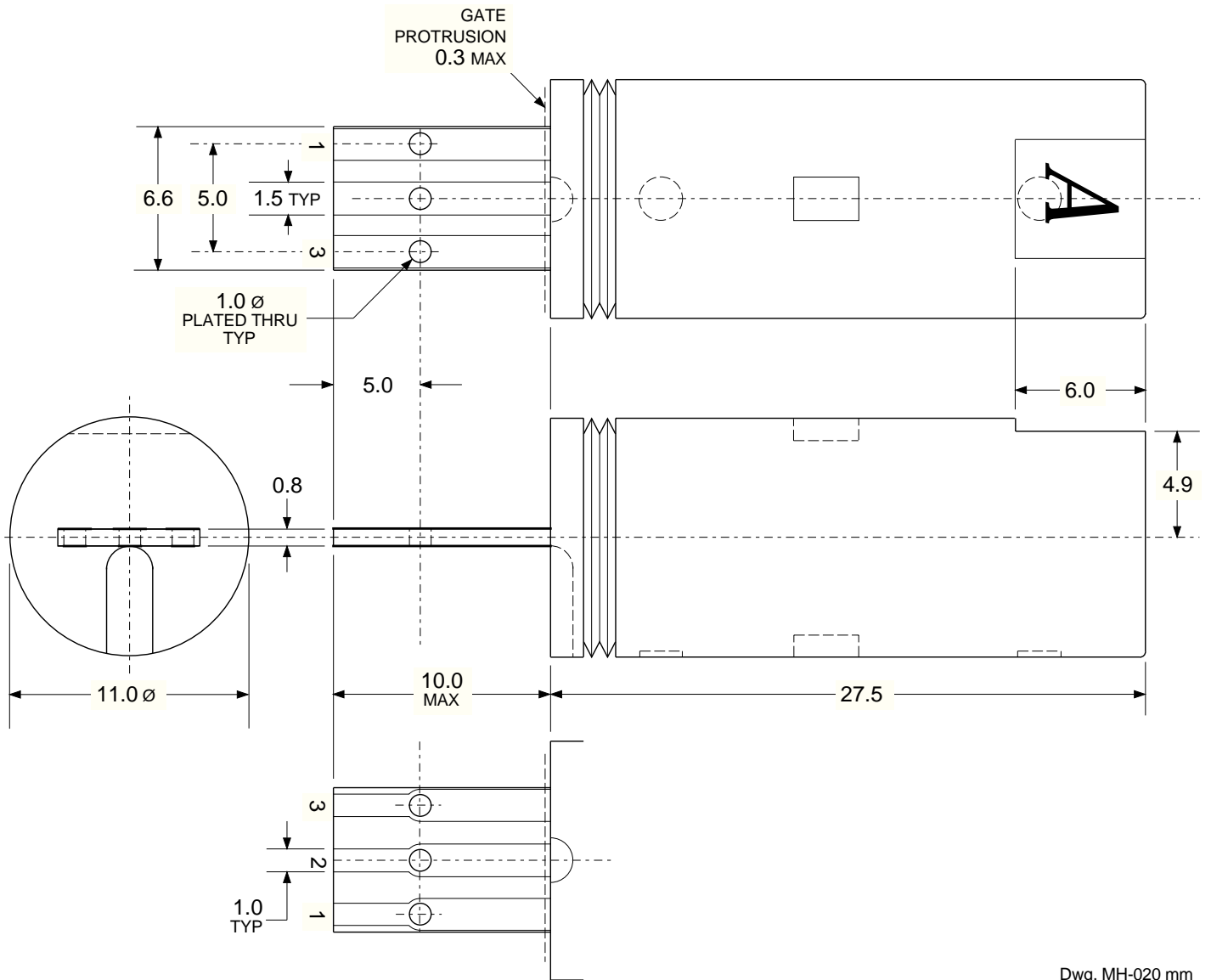

Tolerances unless otherwise specified: 1 place  $\pm 0.1$  mm, 2 places  $\pm 0.05$  mm.

*Allegro MicroSystems, Inc. reserves the right to make, from time to time, such departures from the detail specifications as may be required to permit improvements in the design of its products.*

*The information included herein is believed to be accurate and reliable. However, Allegro MicroSystems, Inc. assumes no responsibility for its use; nor for any infringements of patents or other rights of third parties which may result from its use.*

