

# ATS660LSB

Data Sheet  
27627.107

Some restrictions may apply to certain types of sales. Contact factory for details.

## TRUE ZERO-SPEED, HALL-EFFECT ADAPTIVE GEAR-TOOTH SENSOR

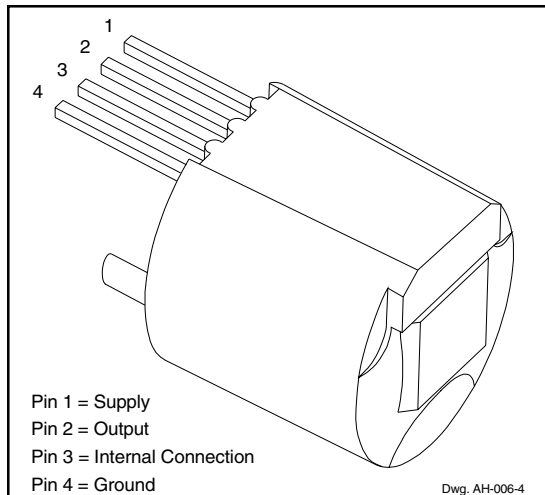

**PRELIMINARY INFORMATION**  
(subject to change without notice)  
October 20, 2000

### ABSOLUTE MAXIMUM RATINGS at $T_A = 25^\circ\text{C}$

Supply Voltage, $V_{CC}$ .....	26.5 V*
Reverse Supply Voltage, $V_{RCC}$ .....	-24 V
Output OFF Voltage, $V_{OUT}$ .....	26.5 V
Reverse Output Voltage, $V_{ROUT}$ .....	-24 V
Continuous Output Current, $I_{OUT}$ .....	20 mA
Reverse Output Current, $I_{ROUT}$ .....	50 mA
Package Power Dissipation, $P_D$ .....	See Graph
Operating Temperature Range, $T_A$ .....	-40°C to +150°C*
Junction Temperature, (continuous), $T_J$ .....	+165°C
(100 hr), $T_{JM}$ .....	+180°C
Storage Temperature, $T_S$ .....	+170°C

\* Operation at increased supply voltages with external circuitry is described in Applications Information. Devices for operation at increased temperatures are available on special order.

The ATS660LSB is an ideal gear-tooth sensor solution for uniform teeth targets as found in today's demanding transmission applications. This digital differential Hall-effect sensor is the choice when repeatability and timing accuracy count. The ATS660LSB incorporates patented self-calibration circuitry (U.S. Pat. 5,917,320) that nulls out the effects of installation air gap, ambient temperature, and magnet offsets to provide superior timing accuracy with symmetrical targets over large operating air gaps — typical of targets used in speed-sensing applications (pitches varying from below 0.5 to over 1.2 teeth per diametric millimeter). The self-calibration at power up keeps the performance optimized over the life of the sensor. The ATS660LSB has an open-collector output for direct digital interfacing with no further signal processing required. This device is available in a small 9-mm diameter by 7-mm long package for optimal manufacturing.

The integrated circuit incorporates a dual-element Hall-effect sensor and signal processing that switches in response to differential magnetic signals created by the ferrous gear teeth. The circuitry contains a sophisticated digital circuit to eliminate magnet and system offsets and to achieve true zero-speed operation. D-to-A converters are used to adjust the device gain at power on and to allow air-gap independent switching, which greatly reduces vibration sensitivity of the device.

### FEATURES AND BENEFITS

- Fully optimized differential digital gear-tooth sensor
- Single-chip sensing IC for high reliability
- High vibration immunity
- Precise duty cycle
- Small mechanical size (9 mm diameter x 7 mm length)
- Automatic gain control circuitry (self calibration)
- True zero-speed operation
- Under-voltage lockout
- Wide operating temperature range
- Optimized Hall IC magnetic circuit
- Digital signal processing
- Large operating air gap range
- Wide operating voltage range
- Excellent repeatability performance
- Defined power-on state

Always order by complete part number: **ATS660LSB** .

# ATS660LSB

## TRUE ZERO-SPEED, HALL-EFFECT ADAPTIVE GEAR-TOOTH SENSOR

### FUNCTIONAL BLOCK DIAGRAM

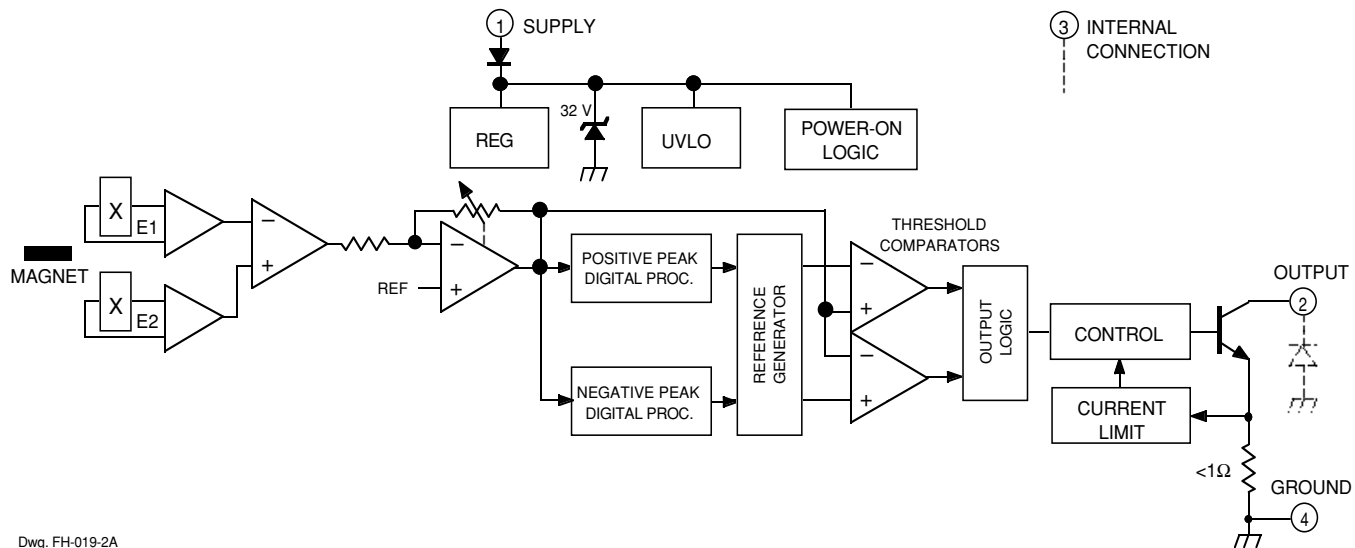

Pin 3 must be externally connected to pin 4.

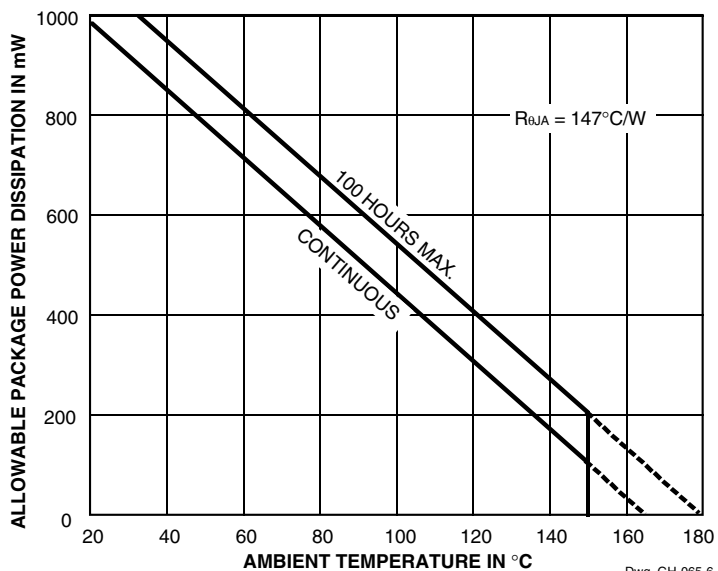

**ATS660LSB**  
**TRUE ZERO-SPEED,**  
**HALL-EFFECT ADAPTIVE**  
**GEAR-TOOTH SENSOR**

**ELECTRICAL CHARACTERISTICS** at  $V_{CC} = V_{OUT} = 12\text{ V}$  and  $T_A = +25^\circ\text{C}$  (unless otherwise noted).

Characteristic	Symbol	Test Conditions	Limits			
			Min.	Typ.	Max.	Units
Supply Voltage	$V_{CC}$	Operating, $T_J < 165^\circ\text{C}$	4.5	12	24	V
Power-On State	POS	$V_{CC} = 0 \rightarrow 5\text{ V}$	HIGH*	HIGH*	HIGH*	–
Under-Voltage Lockout	$V_{CC(UV)}$	$V_{CC} = 0 \rightarrow 5\text{ V}$	4.1	4.2	4.3	V
Low Output Voltage	$V_{OUT(SAT)}$	$I_{OUT} = 20\text{ mA}$	–	0.2	0.4	V
Output Current Limit	$I_{OUTM}$		25	45	55	mA
Output Leakage Current	$I_{OFF}$	$V_{OUT} = 24\text{ V}$	–	0.2	10	$\mu\text{A}$
Supply Current	$I_{CC}$	Output off	3.5	7.0	12	mA
		Output on	5.0	8.5	14	mA
Output Rise Time	$t_r$	$R_L = 500\ \Omega$ , $C_L = 10\text{ pF}$	–	0.2	5.0	$\mu\text{s}$
Output Fall Time	$t_f$	$R_L = 500\ \Omega$ , $C_L = 10\text{ pF}$	–	0.2	5.0	$\mu\text{s}$
Power-On Time	$t_{on}$	Reference gear, $<100\text{ rpm}$	–	–	200	$\mu\text{s}$
Zener Voltage	$V_Z$	$I_{ZT} = \text{TBD}$	–	32	–	V

\* Output transistor is OFF (high logic level).

**ATS660LSB**  
**TRUE ZERO-SPEED,**  
**HALL-EFFECT ADAPTIVE**  
**GEAR-TOOTH SENSOR**

**OPERATION with reference gear at  $T_A = +25^\circ\text{C}$ .**

Characteristic	Symbol	Test Conditions	Limits			
			Min.	Typ.	Max.	Units
Air-Gap Range	AG	Operational	0.5	–	2.5	mm
Calibration Cycle	$n_{\text{cal}}$	Output edges before which calibration is completed	1	1	1	Tooth
Recalibration (Update)	$n_{\text{rcal}}$	Operating	64	64	64	Teeth
Minimum Speed	$v_{\text{min}}$	Teeth (cycles) per second	–	0	–	kHz
Maximum Speed	$v_{\text{max}}$	Teeth (cycles) per second	–	20	–	kHz
Duty Cycle Range	DC	1000 rpm, 0.5 mm < AG < 2.0 mm	–	–	±5	%

**REFERENCE GEAR DIMENSIONS**

Characteristic	Symbol	Description	Limits			
			Min.	Typ.	Max.	Units
Diameter	$D_o$		–	120	–	mm
Tooth Width	T		–	3.0	–	mm
Valley Width	$(p_c - T)$		–	3.0	–	mm
Valley Depth	$h_t$		–	3.0	–	mm
Thickness	F		3.0	–	–	mm

# ATS660LSB TRUE ZERO-SPEED, HALL-EFFECT ADAPTIVE GEAR-TOOTH SENSOR

## TYPICAL CHARACTERISTICS

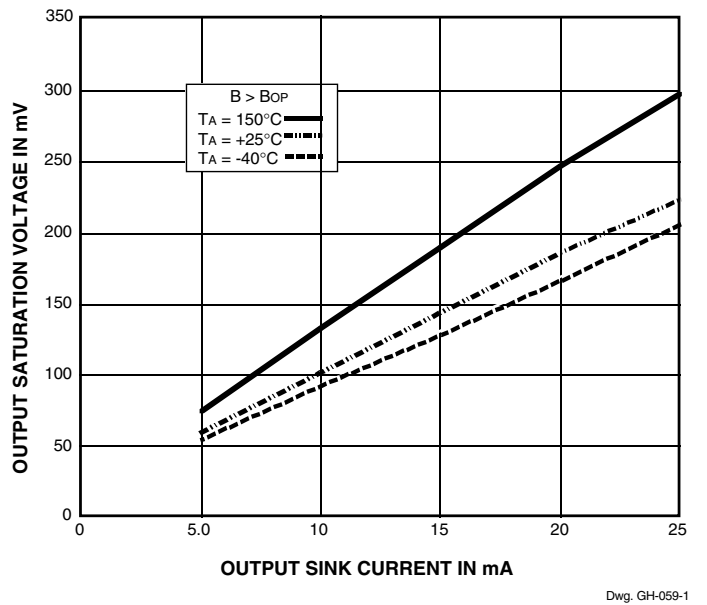
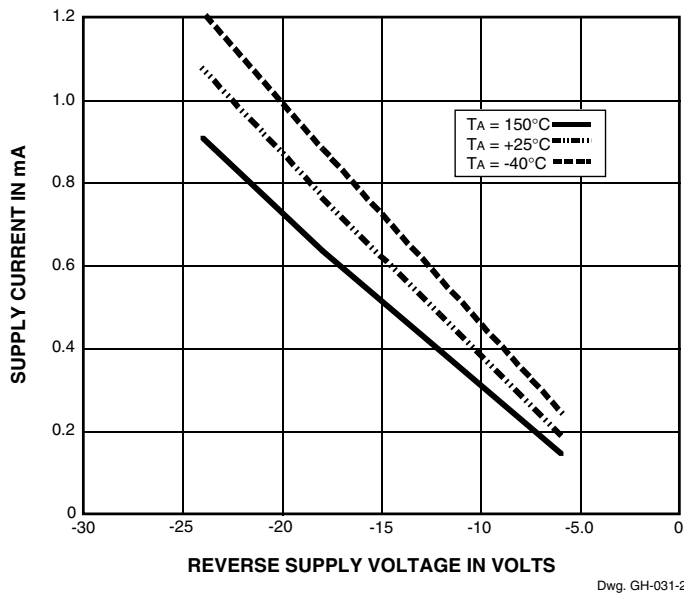
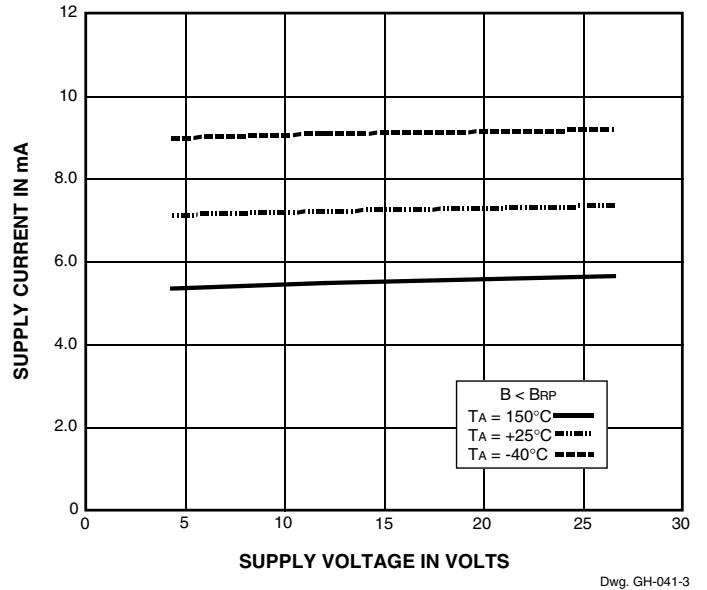
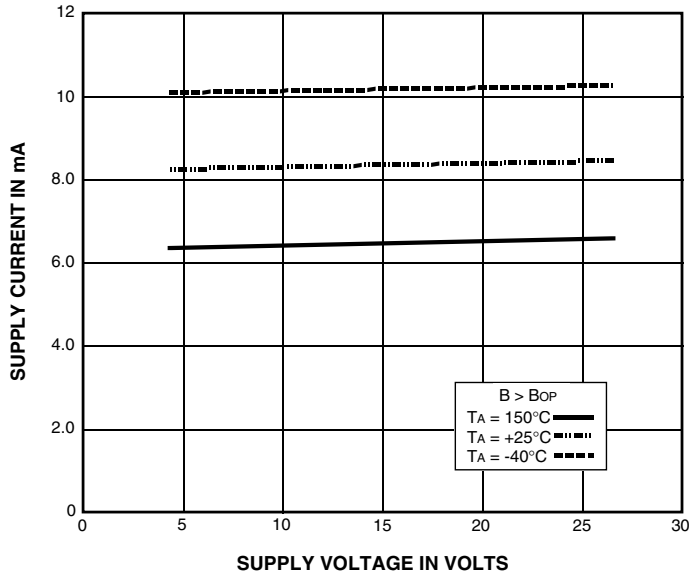

**ATS660LSB**  
***TRUE ZERO-SPEED,***  
***HALL-EFFECT ADAPTIVE***  
***GEAR-TOOTH SENSOR***

TYPICAL DUTY CYCLE AS A FUNCTION OF AIR GAP

— CURVES COMING

# ATS660LSB TRUE ZERO-SPEED, HALL-EFFECT ADAPTIVE GEAR-TOOTH SENSOR

## DEVICE DESCRIPTION

**Subassembly description.** The ATS660LSB true zero-speed gear-tooth sensor system is a Hall IC + magnet configuration that is fully optimized to provide digital detection of gear-tooth\* edges in a small package size. The sensor is packaged in a miniature plastic housing that has been optimized for size, ease of assembly, and manufacturability. High operating-temperature materials are used in all aspects of construction.

The use of the sensor is simple. After correct power is applied to the component, it is capable of instantly providing digital information that is representative of the profile of a rotating gear. No additional optimization or processing circuitry is required. This ease of use should reduce design time and incremental assembly costs for most applications.

**Sensing technology.** The gear-tooth sensor subassembly contains a single-chip differential Hall-effect sensor IC, a samarium-cobalt magnet, and a flat ferrous pole piece. The Hall IC consists of two Hall elements spaced 2.2 mm apart, located so as to measure the magnetic gradient created by the passing of a ferrous object (a gear tooth). The two elements measure the field gradient and convert it to a voltage that is then processed to provide a digital output signal.

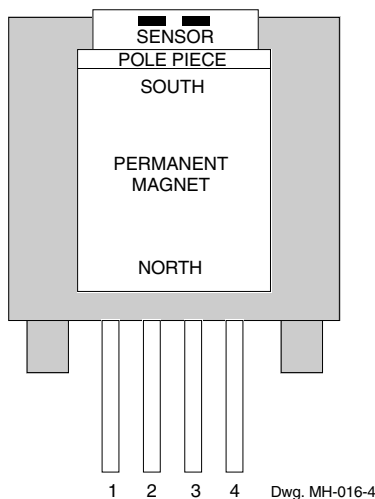

\* In application, the terms “gear” and “target” are often interchanged. However, “gear” is preferred when motion is transferred.

**Internal electronics.** The ATS660LSB is a self-calibrating sensor that contains two Hall-effect elements, a temperature-compensated amplifier, and offset cancellation circuitry. Also contained in the device is a voltage regulator to provide supply rejection over the operating voltage range.

The self-calibrating circuitry is unique. After power up, the device measures the peak-to-peak magnetic signal and adjusts the gain using an on-chip D-to-A converter to make the internal signal amplitude constant independent of the installation air gap of the sensor. This feature allows air-gap-independent operational characteristics.

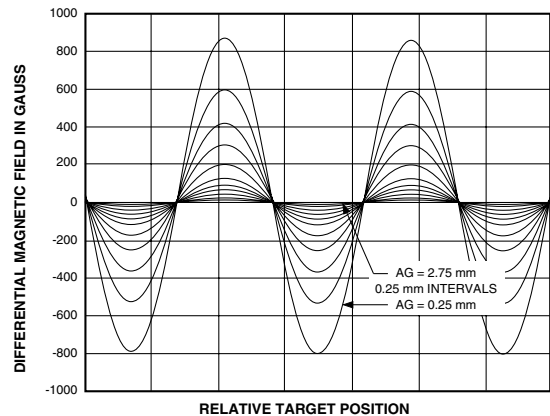

**Magnetic signal**

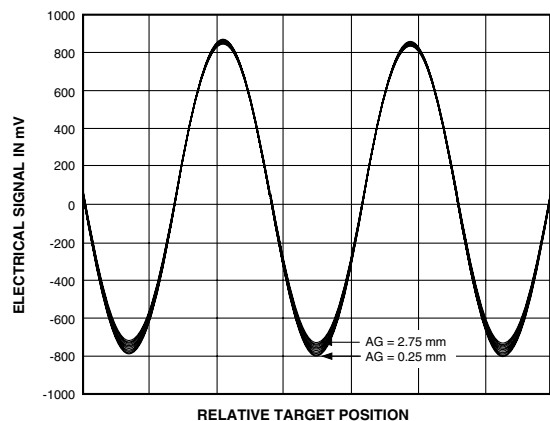

**Electrical signal after gain control**

# **ATS660LSB**

## ***TRUE ZERO-SPEED, HALL-EFFECT ADAPTIVE GEAR-TOOTH SENSOR***

### **DEVICE DESCRIPTION — Continued**

In addition to the gain control circuitry, the device also has provisions to zero out chip, magnet, and installation offsets. This is accomplished using two D-to-A converters that capture the peak and valley of the signal and use them as a reference for the switching comparator. This allows the switch points to be precisely controlled independent of air gap or temperature.

The two Hall transducers and the electronics are integrated on a single silicon substrate using a proprietary BiCMOS process.

**Solution advantages.** The ATS660LSB true zero-speed detecting gear-tooth sensor subassembly uses a differential Hall-element configuration. This configuration is superior in most applications to a classical single-element GTS. The single-element configuration commonly used requires the detection of an extremely small signal (often <100 G) that is superimposed on an extremely large back biased field, often 1500 G to 3500 G. For most gear configurations, the back-biased field values change due to concentration effects, resulting in a varying baseline with air gap, with eccentricities, and with vibration. The differential configuration eliminates the effects of the back-biased field through subtraction and, hence, avoids the issues presented by the single Hall element. The signal-processing circuitry also greatly enhances the functionality of this device. Other advantages are

- temperature drift\* — changes in temperature do not greatly affect this device due to the stable amplifier design and the offset rejection circuitry,
- timing accuracy/duty cycle variation due to air gap\* — the accuracy variation caused by air-gap changes is minimized by the self-calibration circuitry. A two-to-three times improvement can be seen over conventional zero-crossing detectors,
- dual edge detection — because this device references the positive and negative peaks of the signal, dual edge detection is guaranteed,

- immunity to magnetic overshoot — the air-gap independent hysteresis minimizes the impact of overshoot on the switching of device output,
- response to surface defects in the gear — the gain-adjust circuitry reduces the effect of minor gear anomalies that would normally causes false switching,
- immunity to vibration and backlash — the gain-adjust circuitry keeps the hysteresis of the device roughly proportional to the peak-to-peak signal. This allows the device to have good immunity to vibration even when operating at close air gaps,
- immunity to gear run out — the differential-sensor configuration eliminates the base-line variations caused by gear run out, and
- use with stamped-gear configurations — the high-sensitivity switch points allow the use of stamped gears. The shallow mechanical slopes created by the stamping process create an acceptable magnetic gradient down to zero speed. The surface defects caused by stamping the gear are ignored through the use of gain control circuitry.

**Operation versus air-gap/tooth geometry.** Operating specifications are impacted by tooth size, valley size and depth, gear material, and gear thickness. In general, the following guidelines should be followed to achieve greater than 2 mm air gap from the face of unit:

- tooth width (T) > 2 mm;
- valley width ( $p_c - T$ ) > 2 mm;
- valley depth ( $h_t$ ) > 2 mm;
- gear thickness (F) > 3 mm; and the
- gear material must be low-carbon steel.

\* Target must be rotating for proper update algorithm operation.



# ATS660LSB TRUE ZERO-SPEED, HALL-EFFECT ADAPTIVE GEAR-TOOTH SENSOR

## DEVICE DESCRIPTION — Continued

**Power-on state operation.** The device is guaranteed to power on (power up) in the off state (high output voltage) regardless of the presence or absence of a gear tooth.

**Under-voltage lockout.** If the supply voltage falls below the minimum operating voltage ( $V_{CC(UV)}$ ), the device output will turn off (high output voltage) and stay off irrespective of the state of the magnetic field. This prevents false signals caused by under-voltage conditions from propagating through to the output of the sensor.

**Output.** The output of the subassembly is a short-circuit-protected open-collector stage capable of sinking 20 mA. An external pull-up (resistor) to a supply voltage of not more than 26.5 V must be supplied.

**Output polarity.** The output of the device will switch from off to on as the leading edge of the target passes the subassembly in the direction indicated (pin 4 to pin 1), which means that the output voltage will be low when the unit is facing a tooth. If rotation is in the opposite direction (pin 1 to pin 4), the output of the device will switch from on to off as the leading edge of the target passes the subassembly, which means that the output voltage will be high when the unit is facing a tooth.

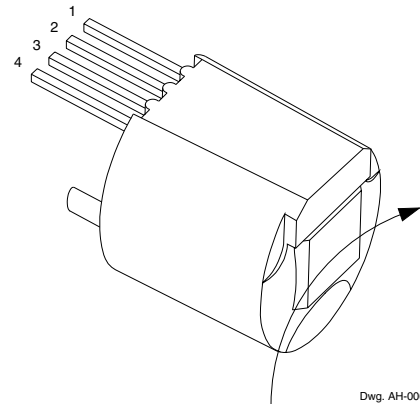

## APPLICATIONS INFORMATION

**Power supply protection.** The device contains an on-chip regulator and can operate over a wide supply voltage range. For devices that need to operate from an unregulated power supply, transient protection should be added externally. For applications using a regulated line, EMI/RFI protection is still required. Incorrect protection can result in unexplained pulses on the output line, providing inaccurate sensing information to the user.

EMI protection circuitry can easily be added to a PC board for use with this device. Provisions have been made for easy mounting of this board on the back of the unit. PC board installation parallel to the device axis is also possible.

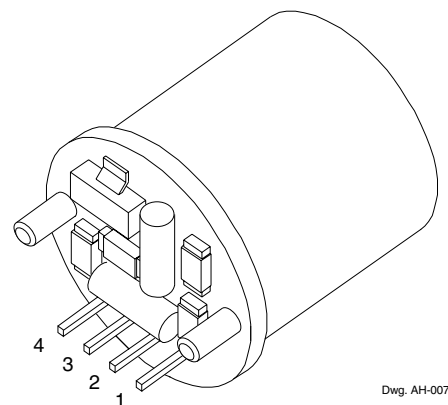

# ATS660LSB

## TRUE ZERO-SPEED, HALL-EFFECT ADAPTIVE GEAR-TOOTH SENSOR

### APPLICATIONS INFORMATION — Continued

**Operation from a regulated power supply.** These devices require minimal protection circuitry during operation from a low-voltage regulated line. The on-chip voltage regulator provides immunity to power supply variations between 4.5 V and 26.5 V. However, even while operating from a regulated line, some supply and output filtering is required to provide immunity to coupled and injected noise on the supply line. A basic RC low-pass circuit ( $R_1C_1$ ) on the supply line and an optional output capacitor ( $C_2$ ) is recommended for operation in noisy environments. Because the device has an open-collector output, an output pull-up resistor ( $R_L$ ) must be included either at the sensor output (pin 2) or by the signal processor input.

**Operation from an unregulated power supply.** In automotive applications, where the device receives its power from an unregulated supply such as the battery, full protection is generally required so that the device can withstand the many supply-side transients. Specifications for such transients vary between car manufacturers, and protection-circuit design should be optimized for each application.

In the circuit shown, a standard protection circuit is constructed using discrete components. The Zener diode is used to provide over-voltage protection against load dumps greater than about 40 V; for load dumps less than about 40 V, the internal Zener is sufficient. The series resistor ( $R$ ) provides current limiting and with the capacitor ( $C$ ) noise filtering. The Zener diode and current-limiting resistor should be sized for power dissipation requirements. The series diode protects the external Zener diode against reverse battery and provides protection against transients greater than -24 V; it must be rated to withstand the most negative transient. In many transmission applications there is already a Zener diode in the TCU, and the diode and external Zener are not necessary.

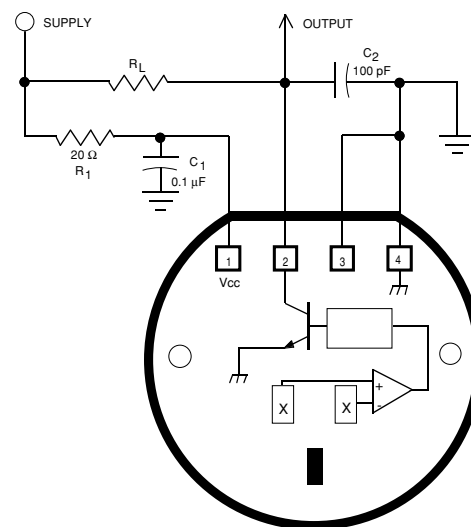

Dwg. EH-008-7

### Operation from regulated supply

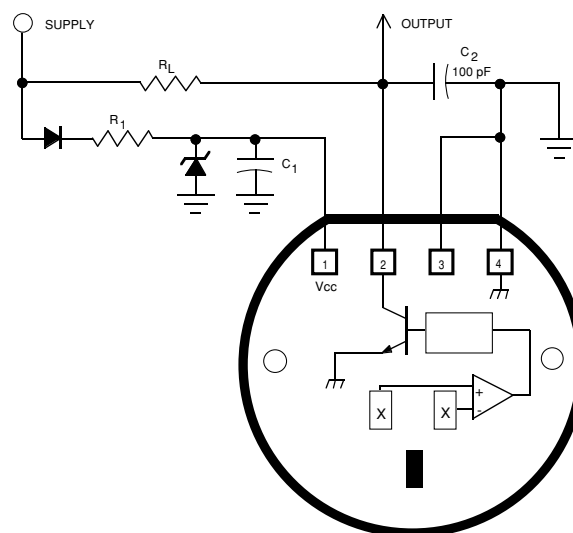

Dwg. EH-008-6

### Operation from unregulated supply

# ATS660LSB TRUE ZERO-SPEED, HALL-EFFECT ADAPTIVE GEAR-TOOTH SENSOR

## APPLICATIONS INFORMATION — Continued

**Recommended evaluation technique.** The self-calibrating feature of the ATS660LSB requires that a special evaluation technique be used to measure its high-accuracy performance capabilities. Installation inaccuracies are calibrated out at power on; hence, it is extremely important that the device be repowered at each air gap when gathering duty cycle data.

The ATS660LSB is designed to minimize performance variation (caused by the large air-gap variations resulting from installation) by self-calibrating at power-on. These functions should be tested using the procedures described below.

Duty cycle capabilities after correct self-calibration can be measured as follows:

1. Set the air gap to the desired value.
2. Power down and then power up the device.
3. Rotate the gear at the desired speed.
4. Wait for calibration to complete (64 output pulses to occur).
5. Monitor output for correct switching and measure accuracy.
6. Repeat the above for multiple air gaps within the operating range of the device.
7. This can be repeated over the entire operating temperature range.

There is an internal update algorithm that will maintain the correct duty cycle as air gap changes with temperature. Large changes in air gap will require the part to be reset (by cycling power) to maintain the correct duty cycle.

Measurement of the effect of changing air gap after power up:

1. Set the air gap to the desired value (nominal, for example). Rotate the gear at the desired speed. Apply power to the subassembly. Wait for 64 output pulses to occur. Monitor output for correct switching and measure accuracy.
2. Change the air gap by  $\pm 0.25$  mm. Do not re-power the subassembly. Wait for update algorithm to finish adjusting thresholds, typically 1 to 2 rotations on a 60-tooth gear.

**Operation with fine-pitch gears.** For targets with a circular pitch of less than 4 mm, a performance improvement can be observed by rotating the front face of the sensor subassembly. This sensor rotation decreases the effective sensor-to-sensor spacing and increases the capability of detecting fine tooth or valley configurations, provided that the Hall elements are not rotated beyond the width of the target.

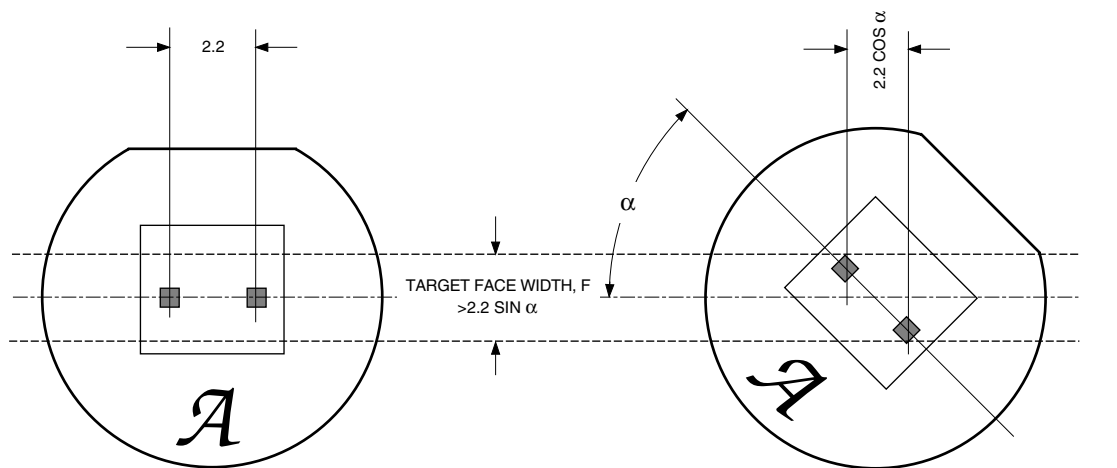

**ATS660LSB**  
**TRUE ZERO-SPEED,**  
**HALL-EFFECT ADAPTIVE**  
**GEAR-TOOTH SENSOR**

**APPLICATIONS INFORMATION — Continued**

**Signal timing accuracy.** The magnetic field profile width is defined by the sensor element spacing and narrows in degrees as the target diameter increases. This results in improved timing accuracy performance for larger gear diameters (for the same number of gear teeth). Valley-to-tooth transitions will generally provide better accuracy than tooth-to-valley transitions for large-tooth or large-valley configurations. For highest accuracy, targets greater than 100 mm in diameter should be used.

**Additional applications Information** on gear-tooth and other Hall-effect sensors is also available in the “Hall-Effect IC Applications Guide”, which can be found in the latest issue of the Allegro MicroSystems Electronic Data Book, AMS-702 or Application Note 27701, or at

[www.allegromicro.com](http://www.allegromicro.com)

**CRITERIA FOR DEVICE QUALIFICATION**

All Allegro sensors are subjected to stringent qualification requirements prior to being released to production. To become qualified, except for the destructive ESD tests, no failures are permitted.

Qualification Test	Test Method and Test Conditions	Test Length	Samples Per Lot	Comments
Temperature Humidity Bias Life	JESD22-A101, $T_A = 85^\circ\text{C}$ , RH = 85%	1000 hrs	77	Device biased for minimum power
Bias Life (Surge Operating Life)	JESD22-A108, $T_A = 150^\circ\text{C}$ , $T_J \leq 165^\circ\text{C}$	1000 hrs	77	
	$T_A = 175^\circ\text{C}$ , $T_J \leq 190^\circ\text{C}$	168 hrs	77	
Autoclave, Unbiased	JESD22-A102, $T_A = 121^\circ\text{C}$ , 15 psig	96 hrs	77	
High-Temperature (Bake) Storage Life	JESD22-A103, $T_A = 170^\circ\text{C}$	1000 hrs	77	
Temperature Cycle	JESD22-A104	1000 cycles	77	$-55^\circ\text{C}$ to $+150^\circ\text{C}$
ESD, Human Body Model	CDF-AEC-Q100-002	Pre/Post Reading	3 per test	Test to failure All leads > x kV

**ATS660LSB**  
**TRUE ZERO-SPEED,**  
**HALL-EFFECT ADAPTIVE**  
**GEAR-TOOTH SENSOR**

**MECHANICAL INFORMATION**

Component	Material	Function	Units
Sensor Face	Thermoset epoxy	Maximum temperature	170°C*
Plastic Housing	Thermoplastic PBT	264 psi deflection temp. (DTUL) 66 psi deflection temp. (DTUL) Approximate melting temperature	204°C 216°C 225°C
Leads	Copper	—	—
Lead Finish	90/10 tin/lead solder plate	—	†
Lead Pull	—	—	8 N

\* Temperature excursions to 225°C for 2 minutes or less are permitted.

† All industry-accepted soldering techniques are permitted for these subassemblies provided the indicated maximum temperature for each component (e.g., sensor face, plastic housing) is not exceeded. Reasonable dwell times, which do not cause melting of the plastic housing, should be used.

**Sensor location (in millimeters)**

(sensor location relative to package center is the design objective)

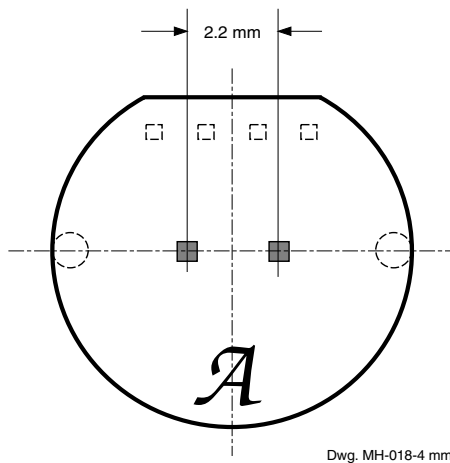

**Lead cross section (in millimeters)**

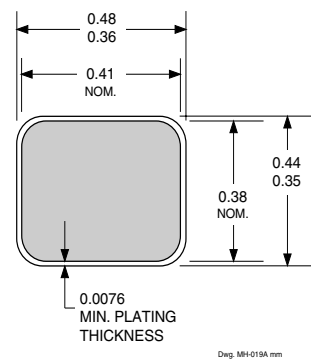

**ATS660LSB**  
**TRUE ZERO-SPEED,**  
**HALL-EFFECT ADAPTIVE**  
**GEAR-TOOTH SENSOR**

**DIMENSIONS IN MILLIMETERS**

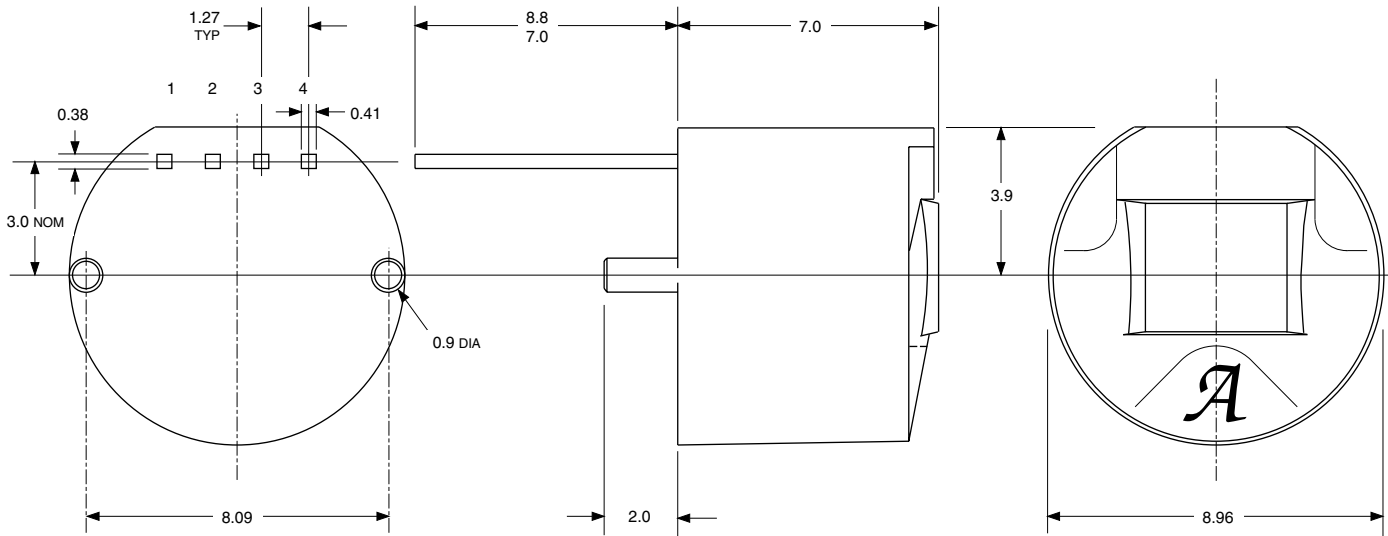

Dwg. MH-017-1B mm

Tolerances, unless otherwise specified: 1 place  $\pm 0.1$  mm, 2 places  $\pm 0.05$  mm.

**ATS660LSB**  
**TRUE ZERO-SPEED,**  
**HALL-EFFECT ADAPTIVE**  
**GEAR-TOOTH SENSOR**

***ADAPTIVE THRESHOLD SENSORS***

<b>Part Number</b>	<b>Operating Temp. Range</b>	<b>Key Applications &amp; Salient Features</b>
ATS610LSA	-40°C to +150°C	Large-tooth, speed sensing – crank angle, cam angle, differential, peak-detecting geartooth sensor (to 20 rpm w/ 0.22 μF)
ATS611LSB	-40°C to +150°C	Fine-pitch, large air gap, speed sensing – transmission speed, ABS, differential, peak-detecting geartooth sensor (to 20 rpm w/ 0.22 μF)
ATS612JSB	-40°C to +115°C	Large/small-tooth speed sensing, differential, peak-detecting geartooth sensor (to 20 rpm w/ 0.22 μF)
ATS632LSA	-40°C to +150°C	Large-tooth, gear-position sensing – cam angle
ATS640JSB	-40°C to +115°C	Small-tooth gear-position sensing for two-wire applications, zero speed

**ATS660LSB**  
**TRUE ZERO-SPEED,**  
**HALL-EFFECT ADAPTIVE**  
**GEAR-TOOTH SENSOR**

*The products described herein are manufactured under one or more of the following U.S. patents: 5,045,920; 5,264,783; 5,442,283; 5,389,889; 5,581,179; 5,517,112; 5,619,137; 5,621,319; 5,650,719; 5,686,894; 5,694,038; 5,729,130; 5,917,320; and other patents pending.*

*Allegro MicroSystems, Inc. reserves the right to make, from time to time, such departures from the detail specifications as may be required to permit improvements in the performance, reliability, or manufacturability of its products. Before placing an order, the user is cautioned to verify that the information being relied upon is current.*

*Allegro products are not authorized for use as critical components in life-support appliances, devices, or systems without express written approval.*

*The information included herein is believed to be accurate and reliable. However, Allegro MicroSystems, Inc. assumes no responsibility for its use; nor for any infringements of patents or other rights of third parties that may result from its use.*