

FEATURES

- InGaP HBT Technology
- High Efficiency 37% CDMA
- Low Receive Band Noise (NR_x) -132 dBm/Hz @ 10 MHz offset
- Low Leakage Current (<5 μA)
- SMT Module Package
- Small Foot Print (6 mm x 6 mm)
- 50 Ω Input and Output Matching
- Low Quiescent Current (I_{cq} = 60 mA Typ)
- Shut Down and Mode Control
- CDMA 2000 1XRTT Compliant
- RoHS Compliant Package Option, 250 °C MSL-3

APPLICATIONS

- 450 MHz Single Mode CDMA Wireless Handsets and Wireless Local Loop

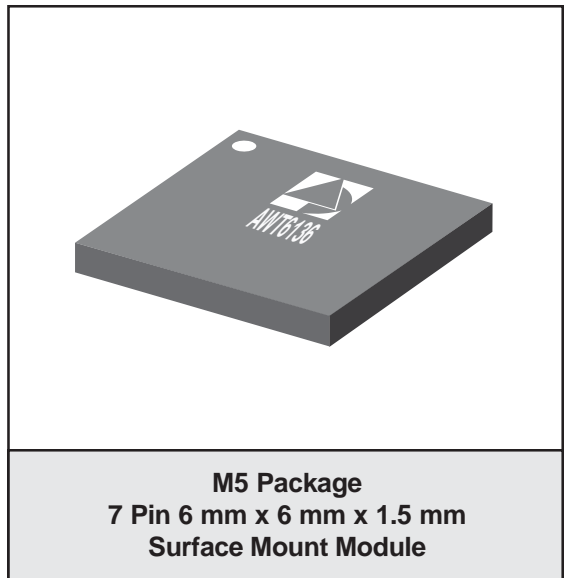

PRODUCT DESCRIPTION

The AWT6136 is a high power, high efficiency amplifier module for CDMA wireless handset applications. The device is manufactured on an advanced InGaP HBT MMIC technology offering state-of-the-art reliability, temperature stability and ruggedness. A low power quiescent current mode

is digitally controlled to reduce power drain on the system battery. The 6 mm x 6 mm x 1.5 mm laminate package is self contained, incorporating 50 Ω input and output matching networks optimized for output power, linearity, and efficiency.

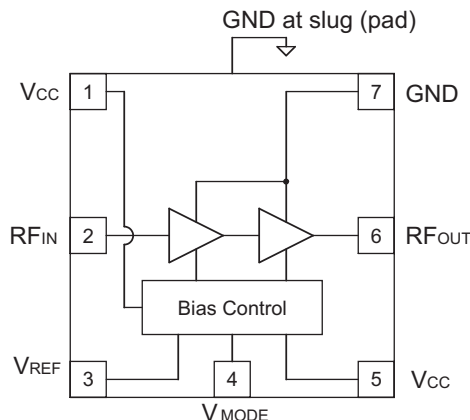

Figure 1: Block Diagram

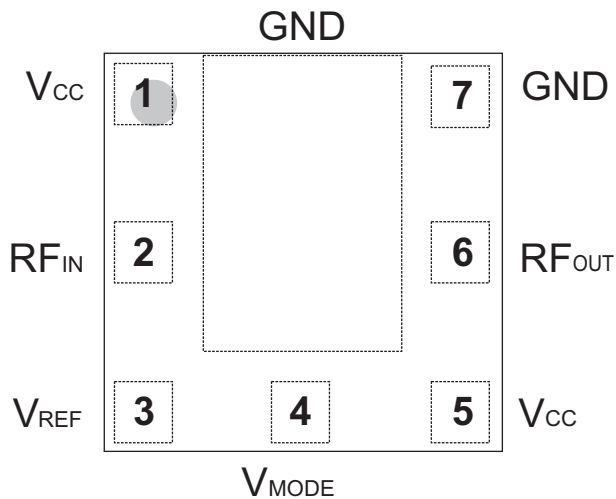

Figure 2: Pinout (X-ray Top View)

Table 1: Pin Description

| PIN | NAME | DESCRIPTION |
|-----|-------------------|-------------------|
| 1 | V _{CC} | Supply Voltage |
| 2 | RF _{IN} | RF Input Signal |
| 3 | V _{REF} | Reference Voltage |
| 4 | V _{MODE} | Mode Control |
| 5 | V _{CC} | Supply Voltage |
| 6 | RF _{OUT} | RF Output |
| 7 | GND | Ground |

ELECTRICAL CHARACTERISTICS

Table 2: Absolute Minimum and Maximum Ratings

| PARAMETER | MIN | MAX | UNIT |
|-------------------------------------|-----|------|------|
| Supply Voltage (V_{CC}) | 0 | +5 | V |
| Mode Control Voltage (V_{MODE}) | 0 | +3.4 | V |
| Reference Voltage (V_{REF}) | 0 | +3.4 | V |
| RF Input Power (P_{IN}) | - | +10 | dBm |
| Storage Temperature (T_{STG}) | -40 | +150 | °C |

Stresses in excess of the absolute ratings may cause permanent damage. Functional operation is not implied under these conditions. Exposure to absolute ratings for extended periods of time may adversely affect reliability.

Table 3: Operating Ranges

| PARAMETER | MIN | TYP | MAX | UNIT | COMMENTS |
|-------------------------------------|----------------------|------------|--------------|------|---------------------------------|
| Operating Frequency (f) | 450 | - | 460 | MHz | |
| Supply Voltage (V_{CC}) | +3.2 | +3.4 | +4.2 | V | |
| Reference Voltage (V_{REF}) | +2.80 0 | +2.90 - | +3.1 +0.5 | V | PA"on" PA"shut down" |
| Mode Control Voltage (V_{MODE}) | +2.5 0 | +2.90 - | +3.1 +0.5 | V | Low Bias Mode High Bias Mode |
| RF Output Power (P_{OUT}) | +29.0 ⁽¹⁾ | +29.5 | - | dBm | CDMA, $V_{CC} = +3.4V$ |
| Case Temperature (T_C) | -10 | - | +90 | °C | |

The device may be operated safely over these conditions; however, parametric performance is guaranteed only over the conditions defined in the electrical specifications.

Notes:

(1) For operation at $V_{CC} = +3.2 V$ and $T_C = +90 °C$, P_{OUT} is derated by 0.5 dB.

Table 4: Electrical Specifications – CDMA Operation
(T_C = +25 °C, V_{CC} = +3.4 V, V_{REF} = +2.90 V, 50 Ω system)

| PARAMETER | MIN | TYP | MAX | UNIT | COMMENTS |
|---|----------|--------------|------------|--------|--|
| Gain | 26 25 | 28.5 27.5 | 30 29 | dB | P _{OUT} = +29.5 dBm, V _{MODE} = 0 V P _{OUT} = +16 dBm, V _{MODE} = +2.90 V |
| Gain Variation | - | 0.4 | 1.0 | dB | |
| Adjacent Channel Power at ±885 kHz offset ⁽¹⁾ Primary Channel BW = 1.23 MHz Adjacent Channel BW = 30 kHz | - - | -50 -58 | -47 -47 | dB | P _{OUT} = +29.5 dBm, V _{MODE} = 0 V P _{OUT} = +16 dBm, V _{MODE} = +2.90 V |
| Adjacent Channel Power at ±1.98 MHz offset ⁽¹⁾ Primary Channel BW = 1.23 MHz Adjacent Channel BW = 30 kHz | - - | -62 -68 | -59 -59 | dB | P _{OUT} = +29.5 dBm, V _{MODE} = 0 V P _{OUT} = +16 dBm, V _{MODE} = +2.90 V |
| Power-Added Efficiency ^{(1), (2)} | 33 6 | 37 7 | - - | % | P _{OUT} = +29.5 dBm, V _{MODE} = 0 V P _{OUT} = +16 dBm, V _{MODE} = +2.90 V |
| Quiescent Current (I _q) | - | 61 | 75 | mA | through V _{CC} pins, V _{MODE} = +2.90 V |
| Reference Current | - | 6.5 | 9 | mA | through V _{REF} pin, PA "on" |
| Mode Control Current | - | 0.8 | 1.0 | mA | through V _{MODE} pin, V _{MODE} = +2.90 V |
| Leakage Current | - | <1 | 5 | μA | V _{CC} = +4.2 V, V _{REF} = 0 V, V _{MODE} = 0 V |
| Noise in Receive Band | - | -132 | -130 | dBm/Hz | f _o +10 MHz, P _{OUT} ≤ +29.5 dBm |
| Harmonics 2f _o 3f _o , 4f _o | - - | -36 -44 | -30 -35 | dBc | P _{OUT} ≤ +29.5 dBm |
| Input Impedance | - | - | 2:1 | VSWR | |
| Spurious Output Level (all spurious outputs) | - | - | -70 | dBc | P _{OUT} ≤ +29.5 dBm In-band Load VSWR < 5:1 Out-of-band Load VSWR < 10:1 Applies over all operating ranges |
| Load mismatch stress with no permanent degradation or failure | 10:1 | - | - | VSWR | Applies over all operating ranges |

Notes:

(1) P_{OUT} is derated by 0.5 dB for IS-98 / CDMA 2000 operation.

(2) Efficiency spec applies at 455 MHz.

APPLICATION INFORMATION

To ensure proper performance, refer to all related Application Notes on the ANADIGICS web site: <http://www.anadigics.com>

Shutdown Mode

The power amplifier may be placed in a shutdown mode by applying logic low levels (see Operating Ranges table) to both the V_{REF} and V_{MODE} voltages.

High Bias Mode

The power amplifier may be placed in a high bias mode by applying a logic low level (see Operating Ranges table) to the V_{MODE} voltage.

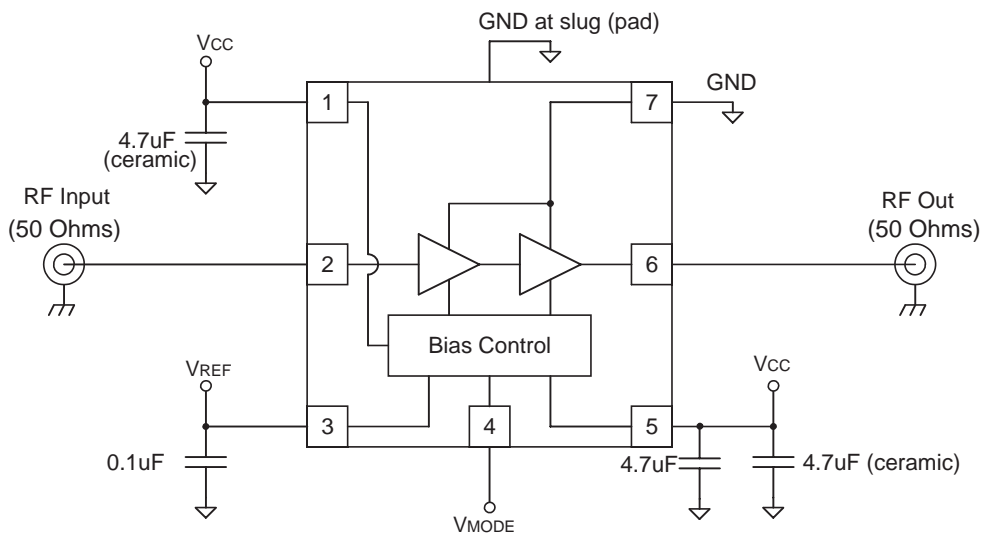
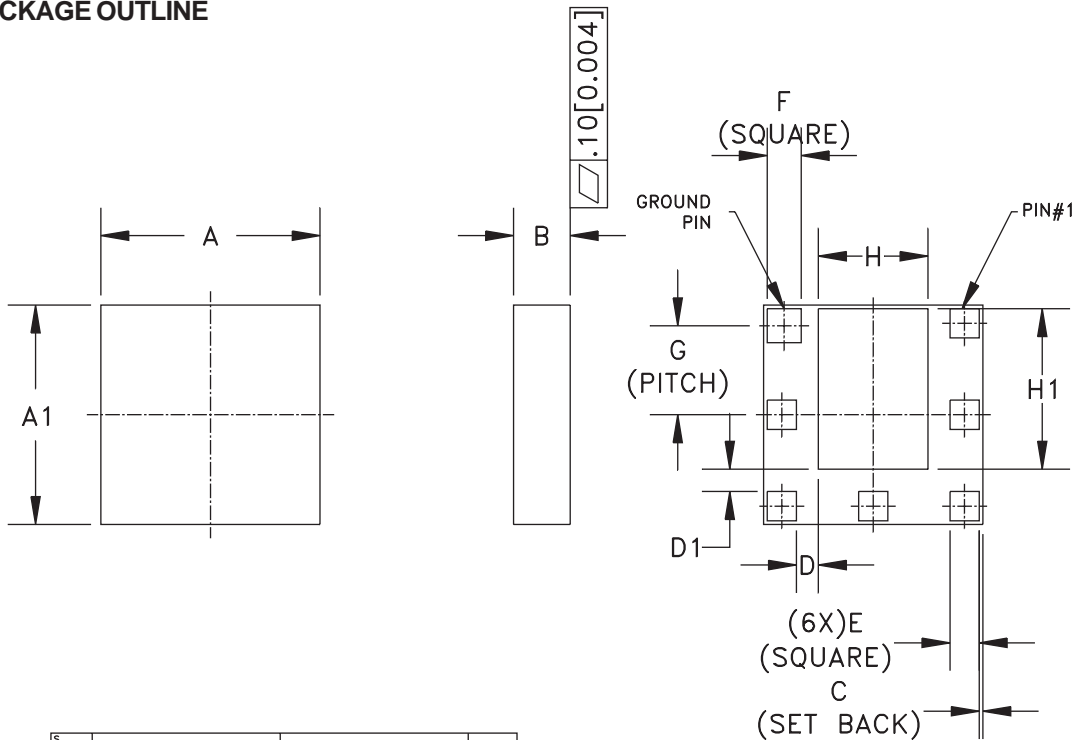

Figure 3: Application Circuit Schematic

PACKAGE OUTLINE



| SYMBOL | MILLIMETERS | | | INCHES | | | NOTE |
|--------|-------------|------|------|-----------|-------|-------|------|
| | MIN. | NOM. | MAX. | MIN. | NOM. | MAX. | |
| A | 5.88 | 6.00 | 6.12 | 0.231 | 0.236 | 0.241 | - |
| A1 | 5.88 | 6.00 | 6.12 | 0.231 | 0.236 | 0.241 | - |
| B | 1.30 | 1.55 | 1.70 | 0.051 | 0.061 | 0.067 | - |
| C | - | 0.10 | - | - | 0.004 | - | - |
| D | - | 0.60 | - | - | 0.024 | - | - |
| D1 | - | 0.60 | - | - | 0.024 | - | - |
| E | - | 0.81 | - | - | 0.032 | - | - |
| F | - | 0.89 | - | - | 0.035 | - | - |
| G | 2.50 BSC | | | 0.098 BSC | | | 3 |
| H | - | 3.00 | - | - | 0.118 | - | - |
| H1 | - | 4.39 | - | - | 0.173 | - | - |

NOTES:

1. CONTROLLING DIMENSIONS: MILLIMETERS
2. UNLESS SPECIFIED TOLERANCE=±0.076 [0.003].
3. REFERENCE ONLY.

Figure 4: M5 Package Outline - 7 Pin 6 mm x 6 mm x 1.5 mm Surface Mount Module (Low Band)

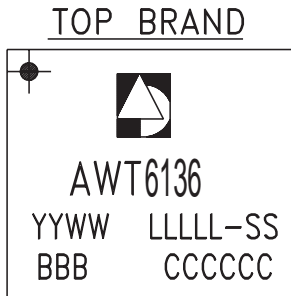

NOTES:

1. ANADIGICS LOGO SIZE: X=0.080±0.010 Y=0.095±0.010
2. PART #: AWT6136
3. YEAR AND WORK WEEK: YYWW: YY = YEAR, WW = WORK WEEK
4. LOT - Wafer I.D.: LLLLL-SS = Wafer/Lot I.D.
5. PIN 1 INDICATOR: MOLD NOTCH -or- INK DOT
6. BOM #: BBB
7. COUNTRY CODE: CCCCC
8. TYPE : ELITE
 SIZE : AS LARGE AS POSSIBLE
 COLOR : WHITE or SILVER INK MARKED

Figure 5: Branding Specification

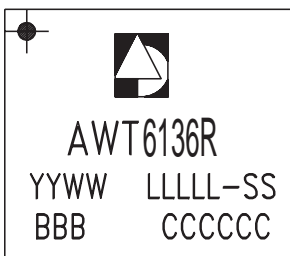
TOP BRAND**NOTES:**

- | | |
|-------------------------|---------------------------------|
| 1. ANADIGICS LOGO SIZE: | X=0.080±0.010 Y=0.095±0.010 |
| 2. PART #: | AWT6136R |
| 3. YEAR AND WORK WEEK: | YYWW: YY = YEAR, WW = WORK WEEK |
| 4. LOT - Wafer I.D.: | LLLL-SS = Wafer/Lot I.D. |
| 5. PIN 1 INDICATOR: | MOLD NOTCH -or- INK DOT |
| 6. BOM #: | BBB |
| 7. COUNTRY CODE: | CCCCC |
| 8. TYPE : | ELITE |
| SIZE : | AS LARGE AS POSSIBLE |
| COLOR : | WHITE or SILVER INK MARKED |

Figure 6: RoHS Compliant Branding Specification

COMPONENT PACKAGING

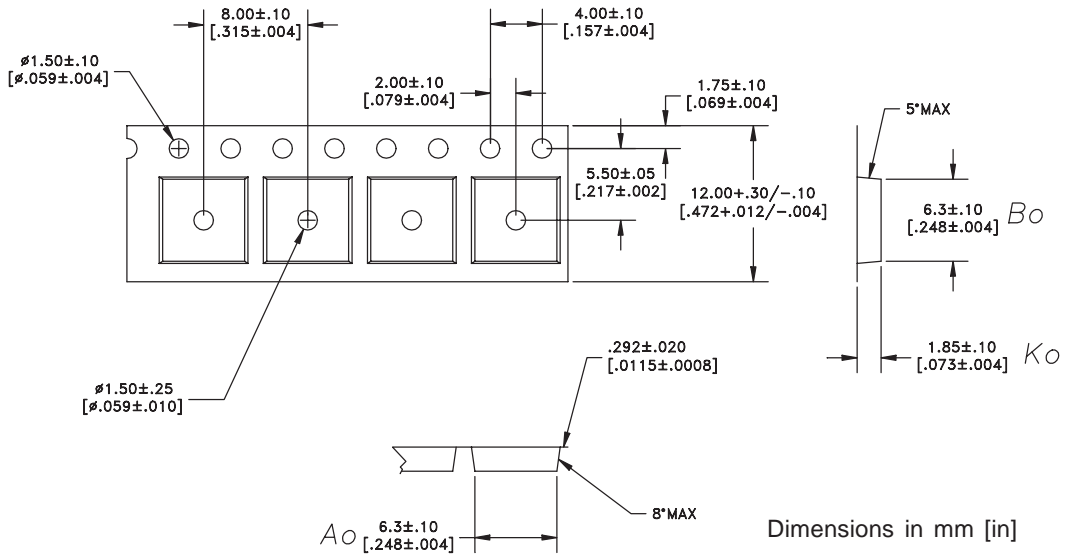

Figure 6: Tape & Reel Packaging

Table 5: Tape & Reel Dimensions

| PACKAGE TYPE | TAPE WIDTH | POCKET PITCH | REEL CAPACITY | MAX REEL DIA |
|----------------|------------|--------------|---------------|--------------|
| 6 x 6 x 1.5 mm | 12mm | 8mm | 2500 | 13" |

NOTES

NOTES

ORDERING INFORMATION

| ORDER NUMBER | TEMPERATURE RANGE | PACKAGE DESCRIPTION | COMPONENT PACKAGING |
|---------------------|--------------------------|---|-------------------------------------|
| AWT6136M5P8 | -10 °C to +90 °C | 7 Pin 6 x 6 x 1.5 mm Surface Mount Module | Tape and Reel, 2500 pieces per Reel |
| AWT6136RM5P8 | -10 °C to +90 °C | RoHS Compliant 7 Pin 6 mm x 6 mm x 1.5 mm Surface Mount Module | Tape and Reel, 2500 pieces per Reel |

**ANADIGICS, Inc.**

141 Mount Bethel Road
Warren, New Jersey 07059, U.S.A.
Tel: +1 (908) 668-5000
Fax: +1 (908) 668-5132

URL: <http://www.anadigics.com>
E-mail: Mktg@anadigics.com

IMPORTANT NOTICE

ANADIGICS, Inc. reserves the right to make changes to its products or to discontinue any product at any time without notice. The product specifications contained in Advanced Product Information sheets and Preliminary Data Sheets are subject to change prior to a product's formal introduction. Information in Data Sheets have been carefully checked and are assumed to be reliable; however, ANADIGICS assumes no responsibilities for inaccuracies. ANADIGICS strongly urges customers to verify that the information they are using is current before placing orders.

WARNING

ANADIGICS products are not intended for use in life support appliances, devices or systems. Use of an ANADIGICS product in any such application without written consent is prohibited.