

# B NIXIE® NUMERICAL INDICATOR TUBE

TYPES  
**B-5750**  
**B-5750S**

The B-5750 NIXIE tube is an ultra-long life, high quality, cold-cathode indicator tube having a common anode. It can display the numerals 0-9 and has two decimal points inside the tube (right and left of the numerals) which are independently operable. The numeral aspect ratio (height to width) has been designed to provide the optimum in readability and viewing distance. The small diameter of the tube (0.530" max) permits 0.540" center-to-center mounting and its short seated height (1.500" max including standoff) allows for minimal instrument panel dimensions.

A moveable pin-straightener-standoff, which is used to align the tube pins for ease of PC layout and insertion, is part of the tube assembly. The standoff also allows solder gas to escape during soldering. These tubes have been specifically designed to operate both in normal DC applications and strobed/time sharing applications (See Note 8).

The B-5750S is identical to the B-5750 except its leads are cut to 0.175" ± .015 for use with the SK-207 socket, Bulletin 1138.

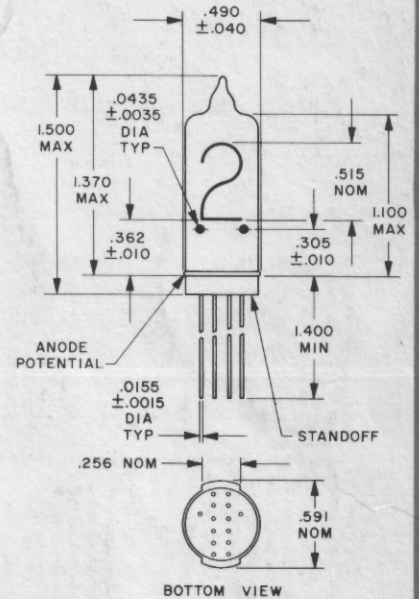

Figure 1. OUTLINE DRAWING  
(NOTE 11)

## ELECTRICAL SPECIFICATIONS

### Absolute Ratings

|   |                     |
|---|---------------------|
| Ionization Voltage (Note 1, Fig. 5)       | +170 Vdc max        |
| Supply Voltage                            | +170 Vdc min        |
| Numeral Cathode Current (Note 5)          | 3.8 ma max          |
| Peak Anode Current<br>(Notes 8 & 9)       | 15 ma max           |
| Decimal Point Cathode Current<br>(Note 6) | 0.1 ma to 0.3 ma    |
| Cathode Pre-bias                          | +60 Vdc to +120 Vdc |

### Typical Operating Conditions (Notes 1, 2 & 7, Figures 5 & 6)

|                                 |            |
|---------------------------------|------------|
| Supply Voltage                  | +170 Vdc   |
| Series Resistor (Table 2)       | 9.1 kΩ     |
| Anode Current (Figure 5)        | 2.6 ma typ |
| Decimal Point Current (Table 2) | 0.2 ma typ |
| Cathode Pre-bias Voltage        | +60 Vdc    |

### Test Conditions (Figures 5 and 6)

### Test Limits (Figures 5 and 6)

## MECHANICAL CHARACTERISTICS

|                       |   |
|-----------------------|---|
| Outline Drawing       | Figure 1                                  |
| Pin Connection        | Table 1                                   |
| Pin Layout            | Figure 2                                  |
| PC Layouts            | Figure 3                                  |
| Weight                | 0.4 oz. max                               |
| Lead Finish           | Hot tin dip from 0.150 in. from tube base |
| Max. Viewing Distance | 24 feet                                   |

|                |                                   |
|----------------|-----------------------------------|
| Mounting       | Note 3                            |
| Color          | Neon red                          |
|                | 3650, 4358, 5654 & 5852 angstroms |
| Basing Diagram | Figure 4                          |
| Brightness     | 200 ft. lamberts                  |
| Soldering Heat | 260 ± 5°C for 10 ± 1 sec.         |
|                | 0.150" from tube base             |

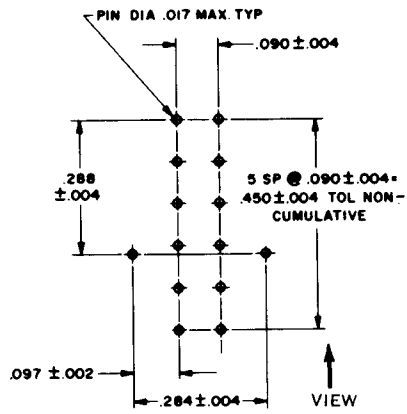

Figure 2. PIN LAYOUT (TOP VIEW)

| PIN | CONNECTIONS |
|-----|-------------|
| 1   | NUMERAL 1   |
| 2   | NUMERAL 2   |
| 3   | NUMERAL 3   |
| 4   | NUMERAL 4   |
| 5   | NUMERAL 5   |
| 6   | NUMERAL 6   |
| 7   | ANODE *     |
| 8   | NUMERAL 7   |
| 9   | NUMERAL 8   |
| 10  | ANODE *     |
| 11  | NUMERAL 9   |
| 12  | NUMERAL 0   |
| 13  | RT DEC PT   |
| 14  | LFT DEC PT  |

\*Anode pins are connected internally

Table 1. PIN CONNECTIONS

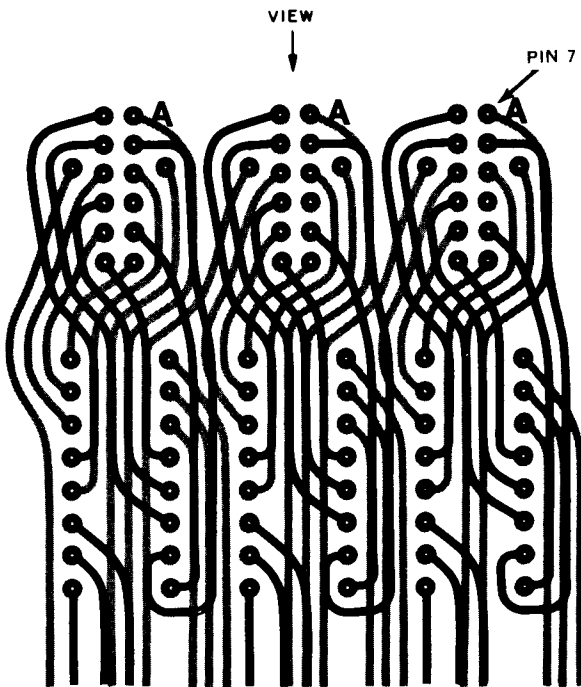

Figure 3a. P.C. LAYOUT WITH FAIRCHILD 9960 (TOP VIEW)  
(9960 notch away from viewer)

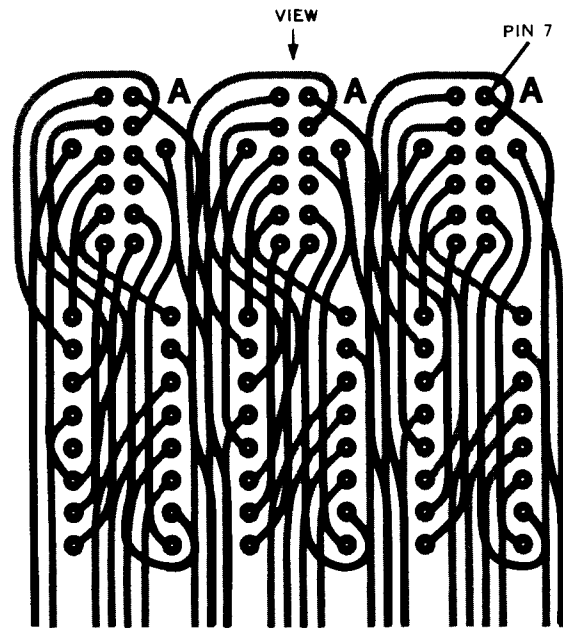

Figure 3b. P.C. LAYOUT WITH TEXAS INSTRUMENTS SN-7441N (TOP VIEW)

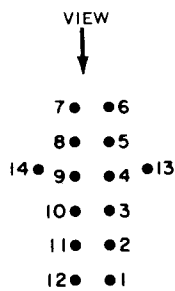
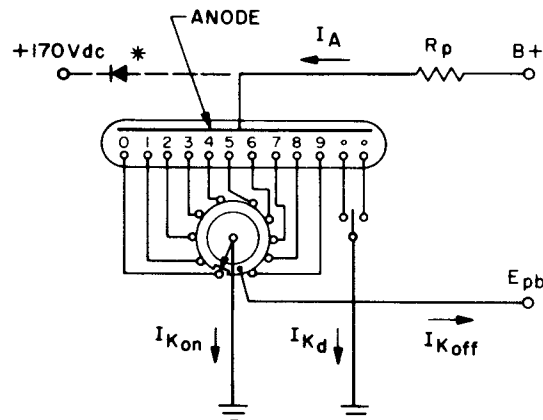

Figure 4. BASING DIAGRAM (BOTTOM VIEW)



\* To test for ionization at +170 Vdc

Figure 5. TEST CIRCUIT

## ENVIRONMENTAL SPECIFICATIONS

|  |   |
|--|---|
| Shock ..... 250 g's, 1.0 msec., 20 total shocks<br>X1, X2, Y1 and Y2 planes<br>Thermal Shock ..... 15 sec., 90°C water - immediate trans-<br>fer to 30°C water, 15 seconds<br>Life Expectancy<br>(dynamic) ..... (200,000 hours) (Note 10) | Ambient temperature —20 to +55°C<br>—40 to 70°C (reduced life)<br>Altitude ..... 70,000 ft.<br>Vibration ..... 10-50-10 cps., 08" total excursion<br>50-2000 cps 10 g's 15 minutes<br>X1, X2, Y1 planes |
|--|---|

## NOTES

1. The minimum supply voltage should be +170 Vdc, however, the use of the highest voltage available with an appropriate series resistor is recommended to provide: 1) greater tolerance of B+ & Rp; 2) more uniform brightness; 3) more constant current operation; 4) improved operation with temperature and 5) improved life. (See Table 2 and Note 7)
2. This NIXIE tube can be used in 4 modes of operation (Figure 5)
  - a) When a numeral is always "on" and a decimal point will never be "on."
  - b) When a numeral is always "on" and a decimal point may or may not be "on."
  - c) When a numeral is always "on" and a decimal point is always "on."
  - d) When a numeral or a decimal point will be "on" but not at the same time (numeral or decimal point are lighted alone) — use the anode resistor plus a decimal point resistor.

In cases a, b and c, only the limiting anode resistor is necessary. (See Table 2)

NOTE: In cases a, b and c, a numeral **must** be "on" when the decimal point is "on" to prevent the decimal point from receiving excessive current.

|                                   |     |     |     |     |
|-----------------------------------|-----|-----|-----|-----|
| Supply Voltage (Vdc)              | 170 | 200 | 250 | 300 |
| Anode Resistor (Rp) (kΩ)          | 9.1 | 20  | 43  | 62  |
| Decimal point resistor (Rkd) (kΩ) | 120 | 270 | 560 | 750 |

Table 2

3. For proper viewing the tube should be oriented so that pins 7 and 6 are closest to the viewer (Figure 4.)
4. As noted on the tube outline drawing (Figure 1) an external portion of the tube is at the anode potential. CAUTION should be exercised.
5. Value when decimal point is "off."
6. Value when only the decimal point is "on."
7. For proper NIXIE tube operation, a load line must pass through the operating region (shaded area) above point "A" and below point "B" in Figure 6. Operation at an anode current below point "A" can result in partial or incomplete numeral glow. Operation at an anode current above point "B" can result in not only spurious numeral glow but also shorter life. Typical load lines for 170 Vdc-10 kΩ, 200 Vdc-22 kΩ, 250 Vdc-43 kΩ, and 300 Vdc-62 kΩ are shown. The limits of the operating region were determined at the 330 V-100 kΩ, 330 V-51.4 kΩ. At these limits the tubes will exhibit an anode current within the limits of 1.8 ma min. and 3.5 ma max. These limits can be used to determine if a tube meets the specification.
8. In a typical strobed/time sharing application, (Figure 7) "same-numeral" cathodes (i.e., all 1's, all 2's, etc.) of all tubes are connected in parallel and the anodes are strobed sequentially. The rapid strobing is above the flicker rate and visual indication is normal. However, since the "on" duty cycle is not 100%, a higher than normal current is used to compensate for loss of brightness. The B-5750 NIXIE tubes are constructed and specified for these peak current conditions and no extraneous glow is exhibited during this operation.
9. The maximum pulse duration is 5.0 milliseconds with a 10% max duty cycle.
10. Under normal DC operating conditions.
11. Lead length on B-5750S is 0.175" ± .015 (for use with SK-207 socket).

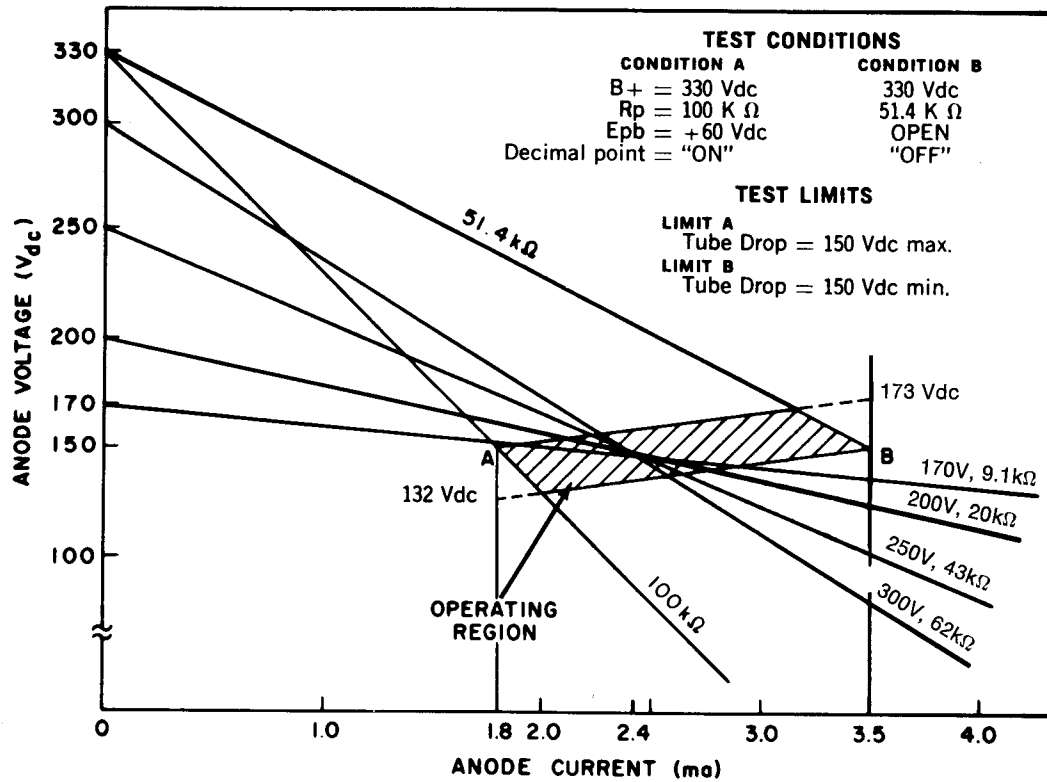

Figure 6. TUBE CHARACTERISTICS (NOTE 7)

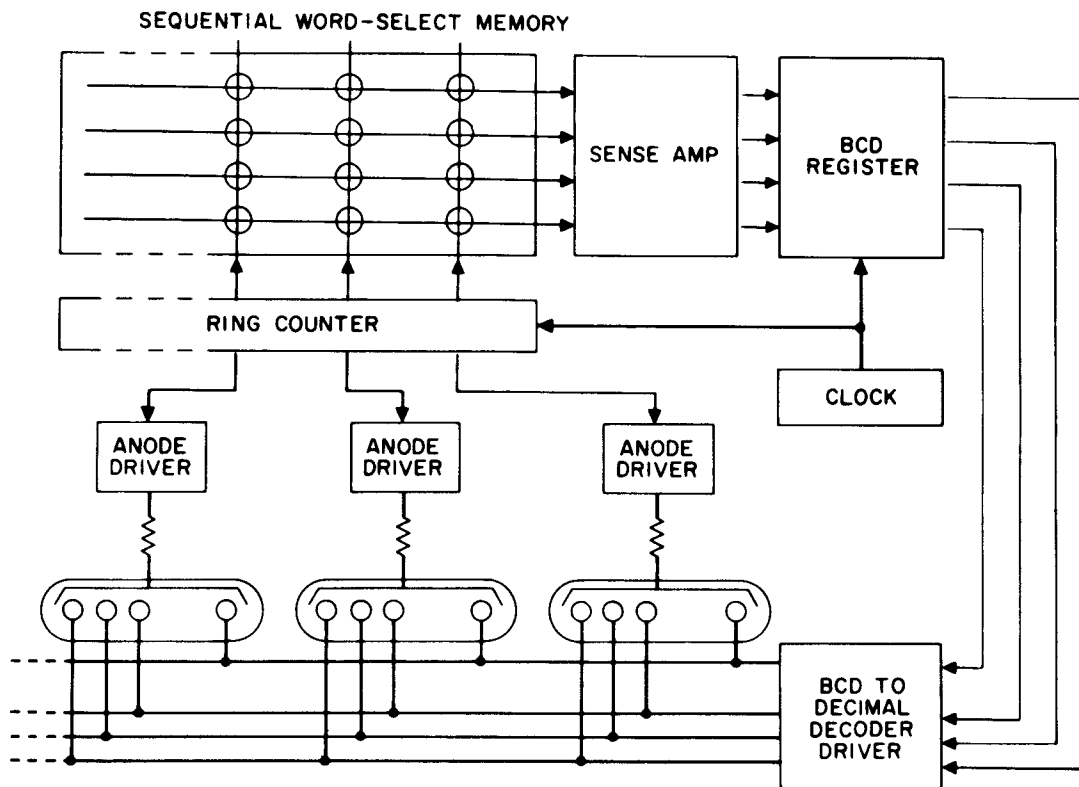

Figure 7. BLOCK DIAGRAM  
TYPICAL TIME SHARING APPLICATION (NOTE 8)