



LOW-POWER, HIGH-DENSITY CENTRAL OFFICE ADSL SOLUTION

FEATURES

- Low-power, high-density Central Office ADSL solution
- Lowest power per channel: less than 1W per channel (worst-case line conditions), including the line driver
- Highest density two-chip solution implements 12 channels of full-rate ADSL
- Smallest modem footprint: production ready design is just 650 mm² per channel, using only eight PCB layers
- Complete standards support: ANSI T1.413 issue2, ITU G.992.1 (G.dmt) Annex A, B, C & H, ITU G.992.2 (G.lite), ITU G.992.3 (ADSL2) Annex A, B, M (extended upstream), L (RE-ADSL), ITU G.992.5 (ADSL2+) Annex A, B, and M
- Fully soft modem implementation supports unprecedented feature richness
- Loop condition testing and capacity estimation on in-service lines

SUMMARY OF BENEFITS

- Superior rate-reach performance
- Proven worldwide interoperability
- System-wide power cut-back techniques deliver in-service power savings and patented power reduction technologies deliver unmatched low-power consumption using standard class AB line drivers
- Complete G.997.1 on chip support enabling remote booting and management (processor-less line cards)
- Shared clocks and power supplies reduce line card cost
- No external devices, such as memory or local processor, are required
- Designed to operate with a wide range of line driver devices
- Full design-in support provided

BladeRunner™ Central Office ADSL System

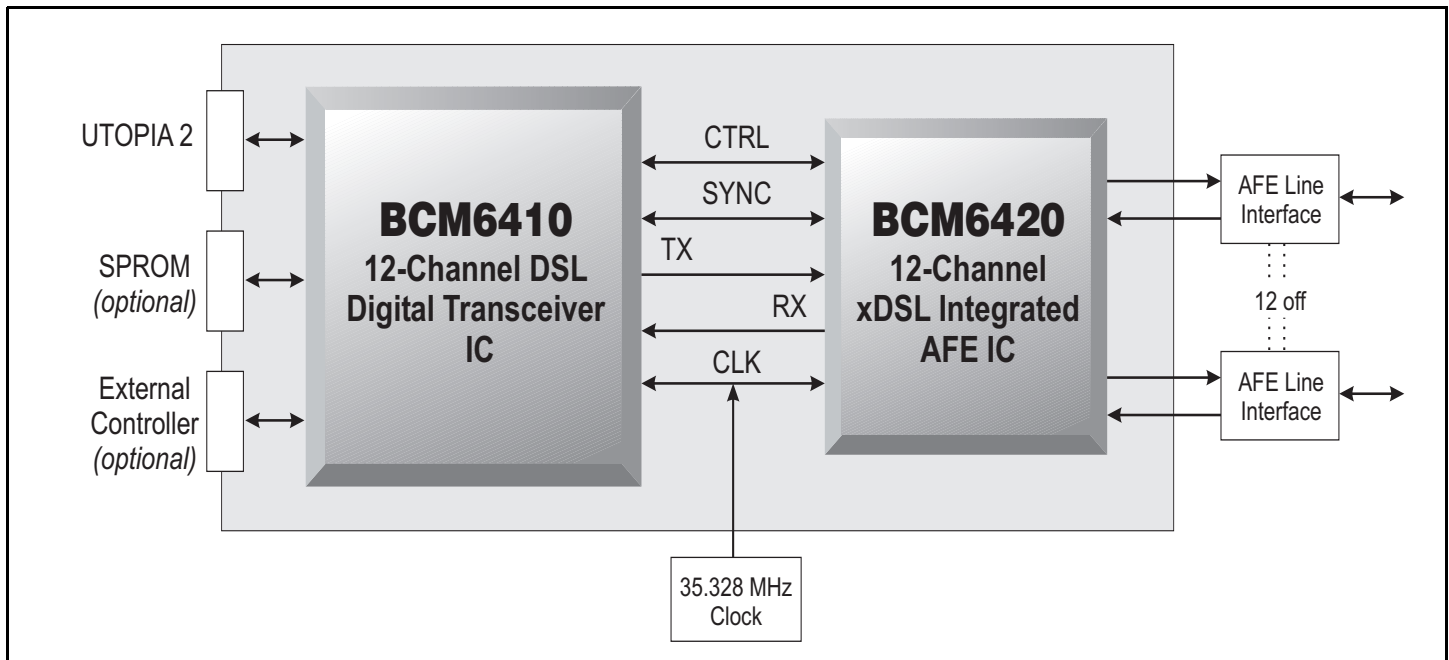

OVERVIEW

The BCM6410 and BCM6420 devices are the first of Broadcom's new BladeRunner™ generation of low-power DSL chipsets designed for very high-density and functionally rich DSLAM and DLC systems.

Powered by Broadcom's ultra-high performance FirePath™ communications processor, optimized for xDSL algorithms, the BCM6410's fully programmable digital design serves as a platform for a low-power and high-density digital transceiver IC.

The BCM6410 standard compliant firmware includes power optimization features such as the Power Crest™ that reduces line drivers power consumption.

The BCM6410 12-channel DSL digital transceiver IC is supplied in a 27mm x 27mm Plastic BGA (336-ball) package. The BCM6420 12-channel xDSL AFE IC is supplied in a 23mm x 23mm Plastic BGA (208-ball) package.

The firmware for the BCM6410/BCM6420 chipset supports ANSI T1.413 issue 2, ITU G.992.1 Annexes A, B, C, and I, ITU G.992.2 (G.lite), ITU G.992.3 (ADSL2) Annex A, B, M, and L, ITU G.992.5 (ADSL2+) and Annex A, B, and M giving complete support for full- and double-rate ADSL, extended upstream ADSL2, Reach Extended RE-ADSL, and up to 29-Mbps ADSL2+.

Future firmware upgrades will track future standards evolution, extend interoperability, and provide higher-layer network functions. Upgrades are supplied to customers as required for all firmware variants, using the same hardware design for all Annexes.

CPE InterOperability

The BladeRunner solution has proven interoperability with a broad range of ADSL CPEs and supports extended rate-reach performance, as well as dual latency and fractional S operations.

Host Messaging Interface Definition

The functionality of the BladeRunner chipset is accessed via a flexible messaging interface. This interface is supported on the local processor port connection and over the in-band management link. A detailed and comprehensive definition of this interface is available to customers and full design-in assistance is provided, including example host codes and graphical user interfaces (GUIs).

Reference Line Card Designs

Broadcom has designed a number of working line cards with generic system connectivity to suit different form factors and channel counts. These serve as references for customer designs, demonstrate the high channel density capability of the Broadcom solution, verify CPE interoperability, and showcase the viability of low-cost volume production. These boards are readily manufactured in high volume at low cost. Broadcom can provide line card design expertise as an integral part of the design support activity.

Evaluation Systems

Broadcom has produced several evaluation systems that use the reference line card designs to quickly prototype working multi-channel ADSL modems. This allows customers to evaluate the benefits of using Broadcom's BladeRunner ADSL chipset, and provides a development platform for system/product prototyping.

Software Development Environment

Broadcom has created a sophisticated software development environment with which to design, build and verify the software base for its FirePath processor core and its ADSL applications. This environment includes a comprehensive commercially available tool chain of processor simulators, assemblers, optimizing compilers, and debugging tools. The software environment includes a robust real-time operating system and flexible software architecture. Using the tool chain, additional functionality can be added to the chipset's firmware tailored to a customer's specific requirements by Broadcom or by the customer—all the necessary support is provided.

Technology White Papers

Broadcom has created a comprehensive base of innovative technology during development of its ADSL products, on which white papers are available. This technology relates to new design processes, the FirePath processor architecture, low-power hardware designs, system-wide power management techniques, optimized software algorithms, and unique ADSL traffic-carrying techniques.

Ordering Information

BCM6410IPB 12-Channel ADSL Digital Transceiver

BCM6420IPB 12-Channel xDSL Integrated AFE

Broadcom®, the pulse logo, BladeRunner™, FirePath™ and Connecting everything® are trademarks of Broadcom Corporation and/or its subsidiaries in the United States and certain other countries. All other trademarks mentioned are the property of their respective owners.

Connecting
everything®



BROADCOM CORPORATION

16215 Alton Parkway, P.O. Box 57013
Irvine, California 92619-7013

© 2004 by BROADCOM CORPORATION. All rights reserved.

6410-6420-PB03-R 06/03/04

Phone: 949-450-8700
Fax: 949-450-8710
E-mail: info@broadcom.com
Web: www.broadcom.com