

DM74LS249

BCD to 7-Segment Decoder with Open-Collector Outputs

General Description

The 'LS249 has active HIGH open-collector outputs and incorporates the Lamp Test and BI/RBO inputs. Additionally, the 'LS249 will light the top bar (segment a) for numeral 6 and the bottom bar (segment d) for numeral 9.

Connection Diagram

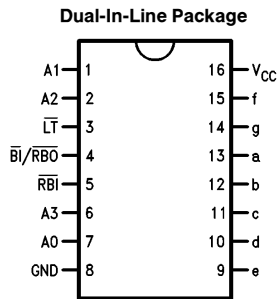

TL/F/10213-1

Logic Symbol

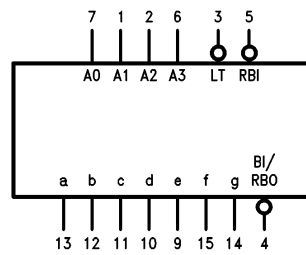

TL/F/10213-2

Order Number DM74LS249N
See NS Package Number N16E

V_{CC} = Pin 16
 GND = Pin 8

Pin Names	Description
A ₀ -A ₃	BCD Inputs
$\overline{\text{BI}}$	Blanking Input (Active LOW)
$\overline{\text{LT}}$	Lamp Test Input (Active LOW)
$\overline{\text{BI/RBO}}$	Blanking Input (Active LOW) or Ripple Blanking Output (Active LOW)
a-g	Segment Outputs (Active HIGH)

Absolute Maximum Ratings (Note)

Supply Voltage	7V
Input Voltage	7V
Operating Free Air Temperature Range	0°C to +70°C
Storage Temperature Range	-65°C to +150°C

Note: The "Absolute Maximum Ratings" are those values beyond which the safety of the device cannot be guaranteed. The device should not be operated at these limits. The parametric values defined in the "Electrical Characteristics" table are not guaranteed at the absolute maximum ratings. The "Recommended Operating Conditions" table will define the conditions for actual device operation.

Recommended Operating Conditions

Symbol	Parameter	Min	Nom	Max	Units
V _{CC}	Supply Voltage	4.75	5	5.25	V
V _{IH}	High Level Input Voltage	2			V
V _{IL}	Low Level Input Voltage			0.8	V
I _{OH}	High Level Output Current ($\overline{BI}/\overline{RBO}$)			-0.25	mA
I _{OL}	Low Level Output Current			8	mA
T _A	Free Air Operating Temperature	0		70	°C

Electrical Characteristics over recommended operating free air temperature range (unless otherwise noted)

Symbol	Parameter	Conditions	Min	Typ (Note 1)	Max	Units
V _I	Input Clamp Voltage	V _{CC} = Min, I _I = -18 mA			-1.5	V
V _{OH}	High Level Output Voltage ($\overline{BI}/\overline{RBO}$)	V _{CC} = Min, I _{OH} = Max V _{IL} = Max	2.7	3.4		V
I _{CEX}	High Level Output Current (a thru g)	V _{CC} = Min, V _O = 5.5V			250	μA
V _{OL}	Low Level Output Voltage	V _{CC} = Min, I _{OL} = Max, V _{IH} = Min		0.35	0.5	V
		I _{OL} = 4 mA, V _{CC} = Min		0.25	0.4	
I _I	Input Current @ Max Input Voltage	V _{CC} = Max, V _I = 7V			0.1	mA
I _{IH}	High Level Input Current	V _{CC} = Max, V _I = 2.7V			20	μA
I _{IL}	Low Level Input Current	V _{CC} = Max, V _I = 0.4V	Inputs		-0.4	mA
			$\overline{BI}/\overline{RBO}$		-1.2	
I _{OS}	Short Circuit Output Current	V _{CC} = Max (Note 2)	-0.3		-2.0	mA
I _{CC}	Supply Current	V _{CC} = Max, V _{IN} = 4.5V			15	mA

Note 1: All typicals are at V_{CC} = 5V, T_A = 25°C.

Note 2: Not more than one output should be shorted at a time, and the duration should not exceed one second.

Switching Characteristics

$V_{CC} = +5.0V, T_A = +25^\circ C$

Symbol	Parameter	$R_L = 2\text{ k}\Omega$		Units
		$C_L = 15\text{ pF}$		
		Min	Max	
t_{PLH} t_{PHL}	Propagation Delay Time A_n to a-g ($54LS R_L = 2\text{ k}\Omega$)		100 100	ns
t_{PLH} t_{PHL}	Propagation Delay Time \overline{BI} to a-g ($54LS R_L = 6\text{ k}\Omega$)		100 100	ns

Numerical Designations—Resultant Displays

0	1	2	3	4	5	6	7	8	9	10	11	12	13	14	15

TL/F/10213-3

Truth Table

Decimal or Function	Inputs						Outputs							Note
	\overline{LT}	A_3	A_2	A_1	A_0	$\overline{BI/RBO}$	a	b	c	d	e	f	g	
0	H	L	L	L	L	H	H	H	H	H	H	H	L	1
1	H	L	L	L	H	H	L	H	H	L	L	L	L	1
2	H	L	L	H	L	H	H	H	L	H	L	L	H	
3	H	L	L	H	H	H	H	H	H	H	L	L	H	
4	H	L	H	L	L	H	L	H	H	L	L	H	H	
5	H	L	H	L	H	H	H	L	H	H	L	H	H	
6	H	L	H	H	L	H	L	L	H	H	H	H	H	
7	H	L	H	H	H	H	H	H	H	L	L	L	L	
8	H	H	L	L	L	H	H	H	H	H	H	H	H	
9	H	H	L	L	H	H	H	H	H	L	L	H	H	
10	H	H	L	H	L	H	L	L	L	H	H	L	H	
11	H	H	L	H	H	H	L	L	H	H	L	L	H	
12	H	H	H	L	L	H	L	H	L	L	L	H	H	
13	H	H	H	L	H	H	H	L	L	H	L	H	H	
14	H	H	H	H	L	H	L	L	L	H	H	H	H	
15	H	H	H	H	H	H	L	L	L	L	L	L	L	
\overline{BI}	X	X	X	X	X	L	L	L	L	L	L	L	L	2
\overline{LT}	L	X	X	X	X	H	H	H	H	H	H	H	H	3

Note 1: $\overline{BI/RBO}$ is wired-AND logic serving as blanking input (\overline{BI}) and/or ripple-blanking output (\overline{RBO}). The blanking out (\overline{BI}) must be open or held at a HIGH level when output functions 0 through 15 are desired. X = input may be HIGH or LOW.

Note 2: When a LOW level is applied to the blanking input (forced condition) all segment outputs go to a LOW level, regardless of the state of any other input condition.

Note 3: When the blanking input/ripple-blanking output ($\overline{BI/RBO}$) is open or held at a HIGH level, and a LOW level is applied to lamp test input, all segment outputs go to a HIGH level.

Logic Diagram

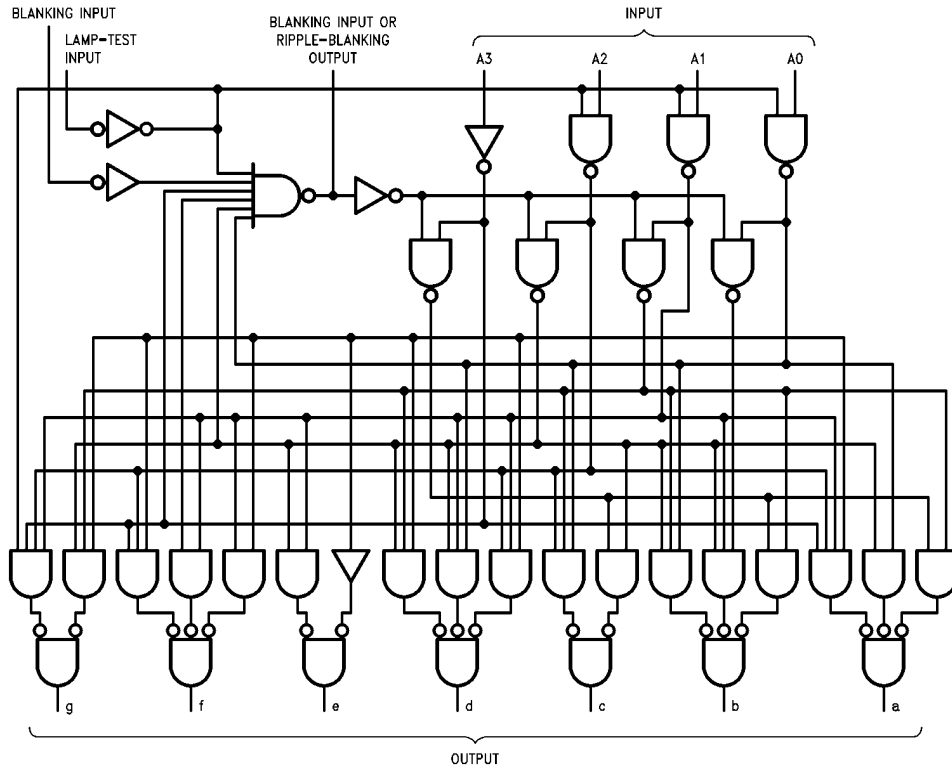

TL/F/10213-4



Physical Dimensions inches (millimeters)

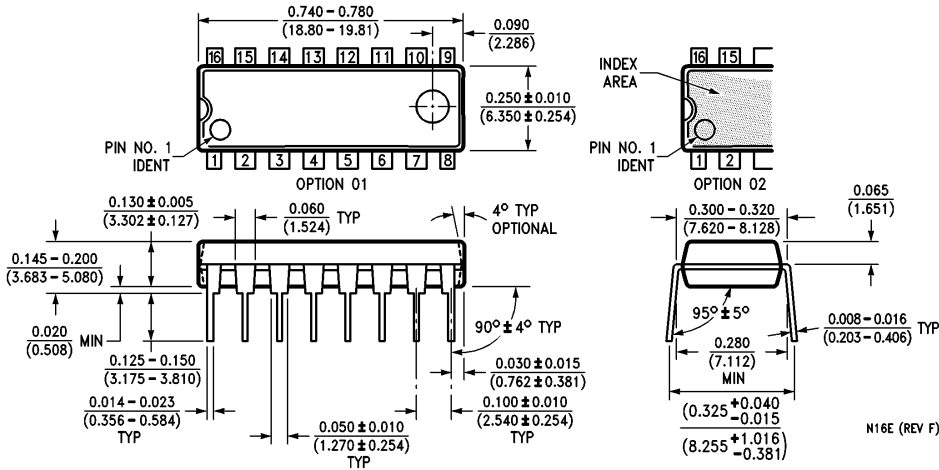

16-Lead Molded Dual-In-Line Package (N)
Order Number DM74LS249N
NS Package Number N16E

N16E (REV F)

LIFE SUPPORT POLICY

NATIONAL'S PRODUCTS ARE NOT AUTHORIZED FOR USE AS CRITICAL COMPONENTS IN LIFE SUPPORT DEVICES OR SYSTEMS WITHOUT THE EXPRESS WRITTEN APPROVAL OF THE PRESIDENT OF NATIONAL SEMICONDUCTOR CORPORATION. As used herein:

1. Life support devices or systems are devices or systems which, (a) are intended for surgical implant into the body, or (b) support or sustain life, and whose failure to perform, when properly used in accordance with instructions for use provided in the labeling, can be reasonably expected to result in a significant injury to the user.
2. A critical component is any component of a life support device or system whose failure to perform can be reasonably expected to cause the failure of the life support device or system, or to affect its safety or effectiveness.



National Semiconductor Corporation
 1111 West Bardin Road
 Arlington, TX 76017
 Tel: 1(800) 272-9959
 Fax: 1(800) 737-7018

National Semiconductor Europe
 Fax: (+49) 0-180-530 85 86
 Email: cnjwge@tevm2.nsc.com
 Deutsch Tel: (+49) 0-180-530 85 85
 English Tel: (+49) 0-180-532 78 32
 Français Tel: (+49) 0-180-532 93 58
 Italiano Tel: (+49) 0-180-534 16 80

National Semiconductor Hong Kong Ltd.
 19th Floor, Straight Block,
 Ocean Centre, 5 Canton Rd.
 Tsimshatsui, Kowloon
 Hong Kong
 Tel: (852) 2737-1600
 Fax: (852) 2736-9960

National Semiconductor Japan Ltd.
 Tel: 81-043-299-2309
 Fax: 81-043-299-2408

National does not assume any responsibility for use of any circuitry described, no circuit patent licenses are implied and National reserves the right at any time without notice to change said circuitry and specifications.