

## GHB-1206-B

### Features

- ✓ 3.2mmx1.6mm SMT LED, 1.1mm THICKNESS.
- ✓ LOW POWER CONSUMPTION.
- ✓ WIDE VIEWING ANGLE.
- ✓ IDEAL FOR BACKLIGHT AND INDICATOR.
- ✓ LOW POWER CONSUMPTION
- ✓ VARIOUS COLORS AND LENS TYPES AVAILABLE.
- ✓ PACKAGE : 2000PCS / REEL.

### Package Dimensions

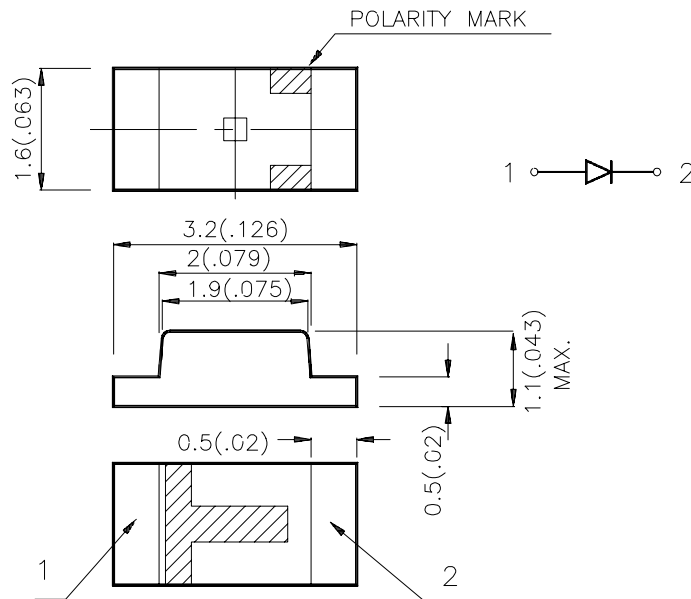

### Notes:

1. All dimensions are in millimeters (inches).
2. Tolerance is 0.2(0.0079") unless otherwise noted.
3. Specifications are subject to change without notice.

## Selection Guide

Part No.	Dice	Lens Type	Iv (mcd) @ 20 mA		Viewing Angle
			Min.	Typ.	
GHB-1206-B	BLUE (GaN)	WATER CLEAR	36	60	120°

Note:

- 1/2 is the angle from optical centerline where the luminous intensity is 1/2 the optical centerline value.

## Electrical / Optical Characteristics at T<sub>A</sub>=25 C

Symbol	Parameter	Device	Typ.	Max.	Units	Test Conditions
peak	Peak Wavelength	Blue	470		n	I <sub>F</sub> =20mA
D	Dominate Wavelength	Blue	470		n	I <sub>F</sub> =20mA
1/2	Spectral Line Half-width	Blue	25		n	I <sub>F</sub> =20mA
C	Capacitance	Blue	105		pF	V <sub>F</sub> =0V;f=1MHz
V <sub>F</sub>	Forward Voltage	Blue	3.3	4.0	V	I <sub>F</sub> =20mA
I <sub>R</sub>	Reverse Current	Blue		10	uA	V <sub>R</sub> = 5V

## Absolute Maximum Ratings at T<sub>A</sub>=25 C

Parameter	Blue	Units
Power dissipation	105	mW
DC Forward Current	30	mA
Peak Forward Current [1]	150	mA
Reverse Voltage	5	V
Operating/Storage Temperature	-40 C To +85 C	

Note:

1. 1/10 Duty Cycle, 0.1ms Pulse Width.

