14.2 mm (0.56 inch) General Purpose Two Digit Seven Segment Displays

Technical Data

HDSP-52xE Series
HDSP-52xG Series
HDSP-52xY Series

Features

- **Industry Standard Size**
- **Industry Standard Pin-Out**
15.24 mm (0.6 in.) DIP Leads
on 2.54 mm (0.1 in.) Centers
- **Choice of Colors**
Red, Green, Yellow
- **Mitered Font**
Mitered Corners on Segments
- **Gray Face Paint**
Gray Package Gives Optimum
Contrast
- **± 50° Viewing Angle**
- **Design Flexibility**
Common Anode or Common
Cathode
- **Categorized for Luminous
Intensity**
- **Green and Yellow
Categorized for Color**

Applications

- **Suitable for Indoor Use**
- **Not Recommended for
Industrial Applications, i.e.
Operating Temperatures
Requirements Exceeding
85°C or Below -35°C^[1]**
- **Extreme Temperature
Cycling Not
Recommended^[2]**

Description

These 14.2 mm (0.56 inch) two digit displays use industry standard size and pin-out. The devices are available as either common anode or common cathode. These gray-faced displays are available in a choice of high efficiency red (HER), green, or yellow colors. The

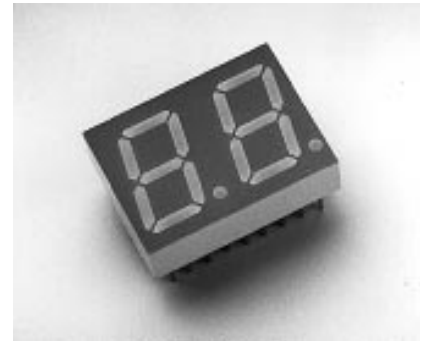

HDSP-521x and HDSP-523x series are suitable for indoor use.

These parts are subjected to Outgoing Quality Assurance (OQA) inspection with AQL of 0.065% for functional and visual/cosmetic rejects.

Devices

HER HDSP-	Green HDSP-	Yellow HDSP-	Description
521E	521G	521Y	Common Anode Right Hand Decimal
523E	523G	523Y	Common Cathode Right Hand Decimal

Notes:

1. For industrial applications, it is recommended to use HDSP-5521/5523/5621/5623/5721/5723.
2. For details, please contact your local Agilent sales office or an authorized distributor.

Part Numbering System

5082 -X X X X-X X X X X

HDSP-X X X X-X X X X X

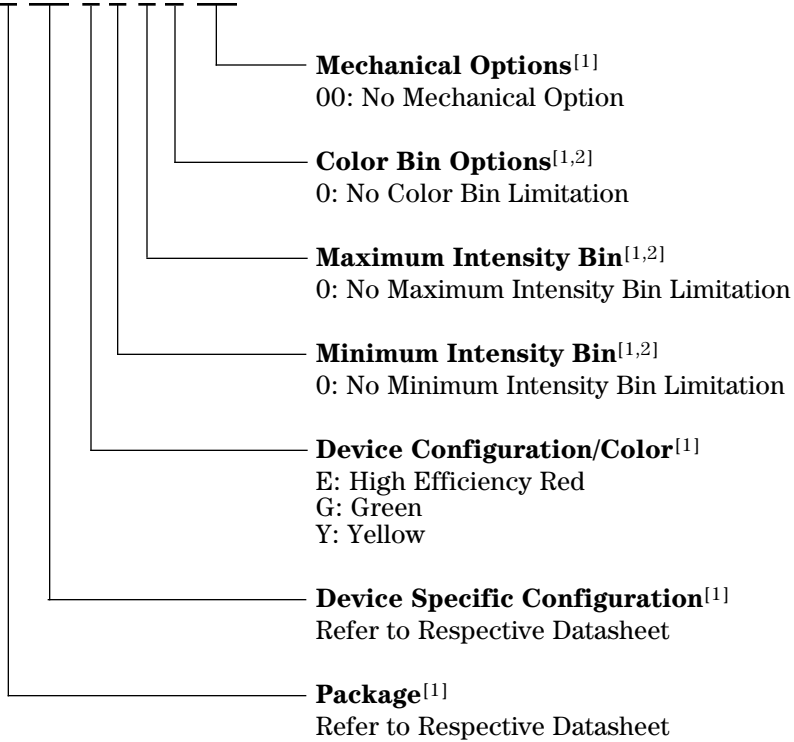

Notes:

- For codes not listed in the figure above, please refer to the respective datasheet or contact your nearest Agilent representative for details.
- Bin options refer to shippable bins for a part number. Color and Intensity Bins are typically restricted to 1 bin per tube (exceptions may apply). Please refer to respective datasheet for specific bin limit information.

Package Dimensions

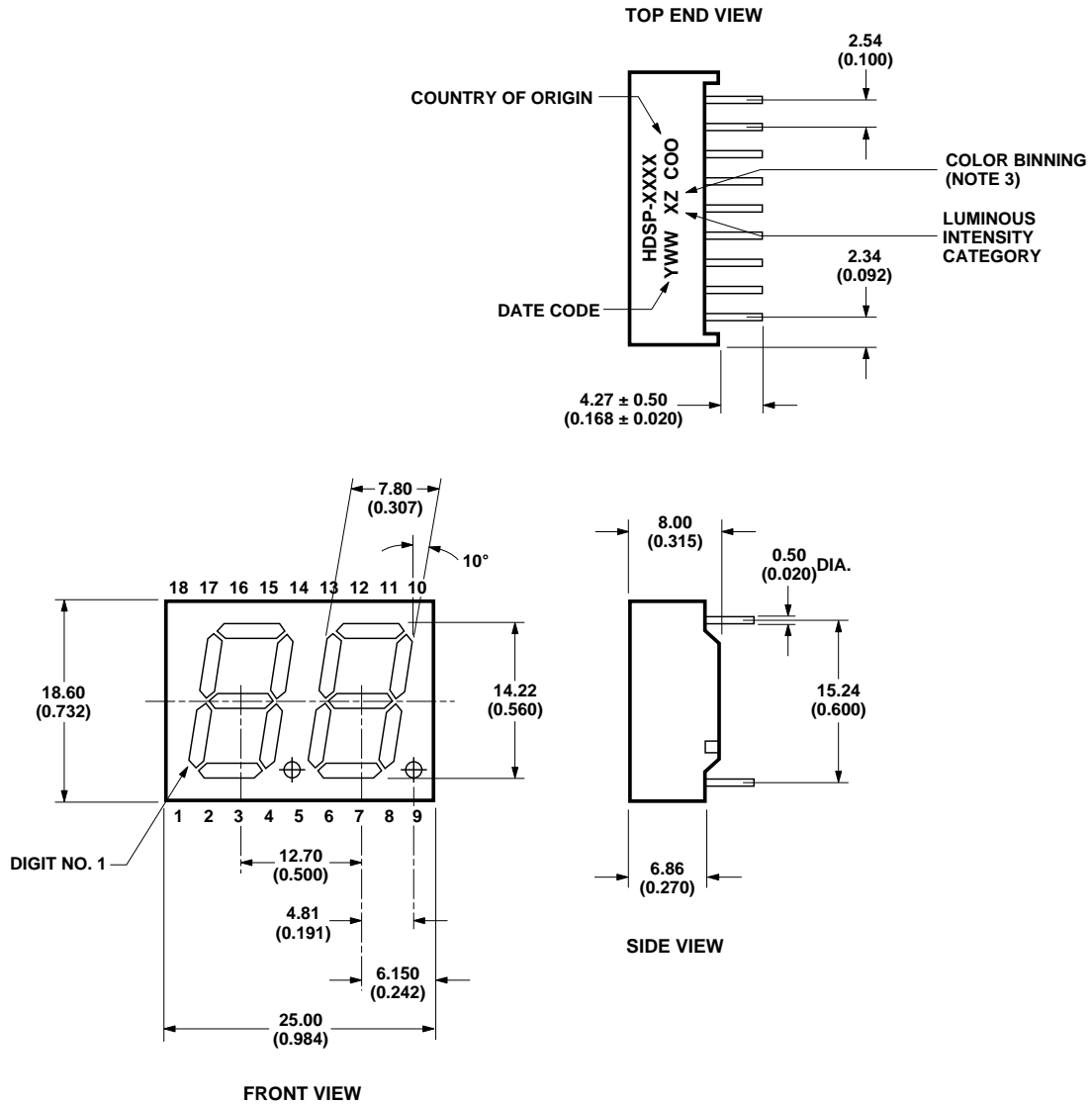

- NOTES:
1. ALL DIMENSIONS ARE IN MILLIMETERS (INCHES).
 2. TOLERANCE IS 0.25 mm (0.01 INCH) UNLESS OTHERWISE STATED.
 3. FOR GREEN AND YELLOW ONLY.

Internal Circuit Diagram

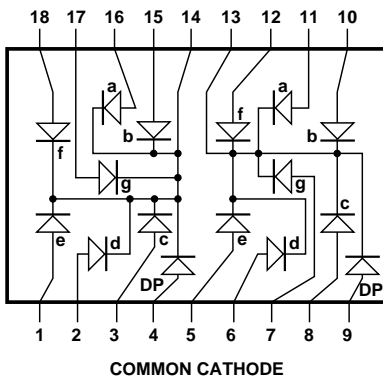
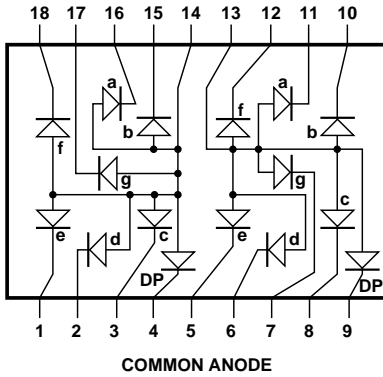

COMMON ANODE		COMMON CATHODE	
PIN	FUNCTION	PIN	FUNCTION
1	E CATHODE NO. 1	1	E ANODE NO. 1
2	D CATHODE NO. 1	2	D ANODE NO. 1
3	C CATHODE NO. 1	3	C ANODE NO. 1
4	DP CATHODE NO. 1	4	DP ANODE NO. 1
5	E CATHODE NO. 2	5	E ANODE NO. 2
6	D CATHODE NO. 2	6	D ANODE NO. 2
7	G CATHODE NO. 2	7	G ANODE NO. 2
8	C CATHODE NO. 2	8	C ANODE NO. 2
9	DP CATHODE NO. 2	9	DP ANODE NO. 2
10	B CATHODE NO. 2	10	B ANODE NO. 2
11	A CATHODE NO. 2	11	A ANODE NO. 2
12	F CATHODE NO. 2	12	F ANODE NO. 2
13	DIGIT NO. 2 ANODE	13	DIGIT NO. 2 CATHODE
14	DIGIT NO. 1 ANODE	14	DIGIT NO. 1 CATHODE
15	B CATHODE NO. 1	15	B ANODE NO. 1
16	A CATHODE NO. 1	16	A ANODE NO. 1
17	G CATHODE NO. 1	17	G ANODE NO. 1
18	F CATHODE NO. 1	18	F ANODE NO. 1

Absolute Maximum Ratings at $T_A=25^\circ\text{C}$

Parameter	HER HDSP-521E HDSP-523E	Green HDSP-521G HDSP-523G	Yellow HDSP-521Y HDSP-523Y	Units
Average Power per Segment or DP	62.5	105	45	mW
Peak Forward Current per Segment or DP (1/10 Duty Cycle, 0.1 ms Pulse Width)	90	90	60	mA
DC Forward Current per Segment or DP ^[1]	25 ^[1]	30 ^[3]	20 ^[2]	mA
Reverse Voltage per Segment or DP	5	5	5	V
Operating Temperature	-35 to +85	-35 to +85	-35 to +85	°C
Storage Temperature	-35 to +85	-35 to +85	-35 to +85	°C
Lead Solder Temperature for 3 seconds ^[4] (2 mm [0.063 in.] Below Seating Plane)	260	260	260	°C

Notes:

- Derate above 25°C at 0.33 mA/°C.
- Derate above 25°C at 0.27 mA/°C.
- Derate above 40 celcius at 0.35 mA/celcius.
- Not recommended to be soldered more than 2 times. Minimum interval between solderings is 15 minutes. Total soldering time not to exceed 5 seconds.

Optical/Electrical Characteristics at $T_A=25^\circ\text{C}$

High Efficiency Red

Devices HDSP-	Parameter	Symbol	Min.	Typ.	Max.	Units	Test Conditions
521E	Luminous Intensity/Segment (Segment Average) ^[1,2]	I_V	2.28	4.00	7.69	mcd	$I_F = 10 \text{ mA}$
	Forward Voltage/Segment or DP	V_F		2.05	2.60	V	$I_F = 20 \text{ mA}$
523E	Peak Wavelength	λ_{PEAK}		640		nm	
	Dominant Wavelength ^[3]	λ_d		628		nm	$I_F = 10 \text{ mA}$
	Reverse Voltage/Segment or DP ^[4]	V_R	5.0			V	$I_R = 100 \mu\text{A}$
	Temperature Coefficient of V_F /Segment or DP	$\Delta V_F/^\circ\text{C}$		-2		mV/°C	

Green

Devices HDSP-	Parameter	Symbol	Min.	Typ.	Max.	Units	Test Conditions
521G	Luminous Intensity/Segment (Segment Average) ^[1,2]	I_V	2.28	3.50	5.13	mcd	$I_F = 10 \text{ mA}$
	Forward Voltage/Segment or DP	V_F		2.0	2.4	V	$I_F = 10 \text{ mA}$
523G	Peak Wavelength	λ_{PEAK}		568		nm	
	Dominant Wavelength ^[3]	λ_d	564.5	570	576.5	nm	$I_F = 10 \text{ mA}$
	Reverse Voltage/Segment or DP ^[4]	V_R	5.0			V	$I_R = 100 \mu\text{A}$
	Temperature Coefficient of V_F /Segment or DP	$\Delta V_F/^\circ\text{C}$		-2		mV/°C	

Yellow

Devices HDSP-	Parameter	Symbol	Min.	Typ.	Max.	Units	Test Conditions
521Y 523Y	Luminous Intensity/Segment (Segment Average) ^[1,2]	I_V	1.52	2.30	5.13	mcd	$I_F = 10 \text{ mA}$
	Forward Voltage/Segment or DP	V_F		2.1	2.4	V	$I_F = 20 \text{ mA}$
	Peak Wavelength	λ_{PEAK}		589		nm	
	Dominant Wavelength ^[3]	λ_d	582.0	587	592.0	nm	$I_F = 10 \text{ mA}$
	Reverse Voltage/Segment or DP ^[4]	V_R	5.0			V	$I_R = 100 \mu\text{A}$
	Temperature Coefficient of V_F /Segment or DP	$\Delta V_F/^\circ\text{C}$		-2		mV/°C	

Notes:

- Case temperature of the device immediately prior to the intensity measurement is 25°C.
- The digits are categorized for luminous intensity. The intensity category is designated by a letter on the side of the package.
- The dominant wavelength, λ_d , is derived from the CIE chromaticity diagram and represents the single wavelength which defines the color of the device.
- Typical specification for reference only. Do not exceed absolute maximum ratings.

Intensity Bin Limits^[1] (mcd at 10 mA)

Bin Name	Yellow		GREEN		HER	
	Min. ^[2]	Max. ^[2]	Min. ^[2]	Max. ^[2]	Min. ^[2]	Max. ^[2]
F	1.52	2.28	NA	NA	NA	NA
G	2.28	3.42	2.28	3.42	2.28	3.42
H	3.42	5.13	3.42	5.13	3.42	5.13
I	NA	NA	NA	NA	5.13	7.69

Notes:

- Bin categories are established for classification of products. Products may not be available in all bin categories.
- Tolerance for each bin limit is $\pm 10\%$.

Color Categories (Dominant Wavelength)

Bin Name	GREEN	
	Min. ^[2]	Max. ^[2]
3	570.5	573.5
2	573.5	576.5

Bin Name	YELLOW	
	Min. ^[2]	Max. ^[2]
2	587.00	589.50
3	584.50	587.00

Notes:

- Bin categories are established for classification of products. Products may not be available in all bin categories.
- Tolerance for each bin limit is $\pm 1 \text{ nm}$.

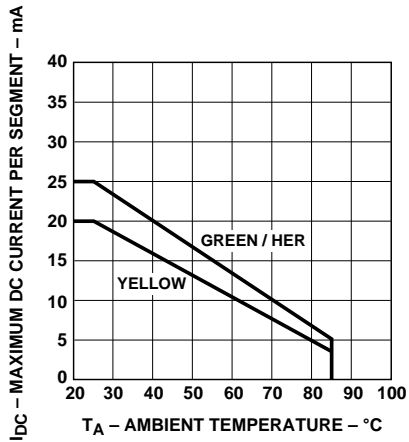

Figure 1. Maximum Allowable DC Current vs. Ambient Temperature.

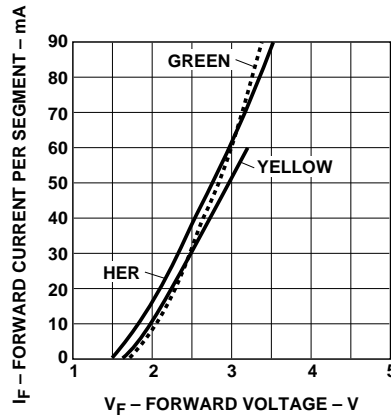

Figure 2. Forward Current vs. Forward Voltage.

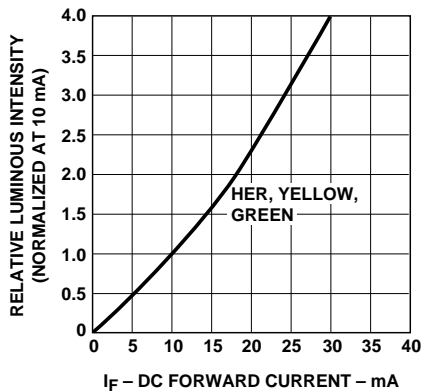

Figure 3. Relative Luminous Intensity vs. DC Forward Current.

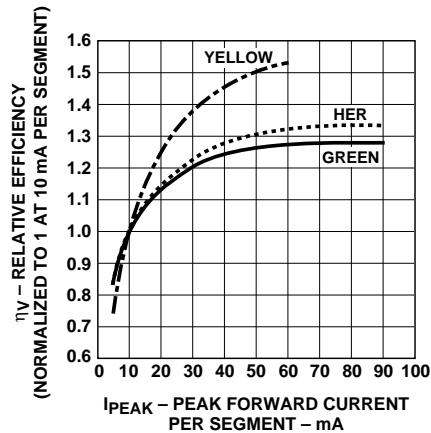

Figure 4. Relative Efficiency (Luminous Intensity per Unit Current) vs. Peak Current.

Contrast Enhancement

For information on contrast enhancement, please see Application Note 1015.

Soldering/Cleaning

Cleaning agents from the ketone family (acetone, methyl ethyl ketone, etc.) and from the chlorinated hydrocarbon family (methylene chloride, trichloroethylene, carbon tetrachloride, etc.) are not recommended for cleaning LED parts. All of these various solvents attack or dissolve the encapsulating epoxies used to form the package of plastic LED parts.

For information on soldering LEDs please refer to Application Note 1027.

Device Reliability

For reliability information, please see the reliability data sheet 14.2 mm (0.56 inch) General Purpose Two Digit Seven Segment Display.

www.agilent.com/semiconductors

For product information and a complete list of distributors, please go to our web site.

For technical assistance call:

Americas/Canada: +1 (800) 235-0312 or
(408) 654-8675

Europe: +49 (0) 6441 92460

China: 10800 650 0017

Hong Kong: (+65) 271 2451

India, Australia, New Zealand: (+65) 271 2394

Japan: (+81 3) 3335-8152(Domestic/International), or 0120-61-1280(Domestic Only)

Korea: (+65) 271 2194

Malaysia, Singapore: (+65) 271 2054

Taiwan: (+65) 271 2654

Data subject to change.

Copyright © 2001 Agilent Technologies, Inc.

Obsoletes 5988-0376EN

January 9, 2002

5988-5378EN