

HOA1887

Transmissive Sensor

FEATURES

- Choice of phototransistor or photodarlington output
- Side mount package
- Ambient light and dust protective filter
- Accurate position sensing
- 0.010 in.(0.25mm) aperture windows
- 0.125 in.(3.18 mm) slot width
- 24.0 in.(610 mm) min. 26 AWG UL 1429 leads

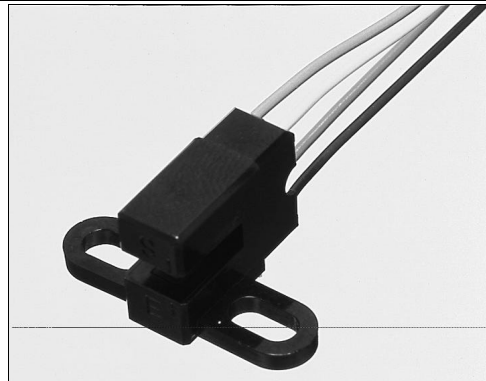

INFRA-89.TIF

DESCRIPTION

The HOA1887 series consists of an infrared emitting diode facing an NPN silicon phototransistor (HOA1887-011, -012) or photodarlington (HOA1887-013) encased in a black thermoplastic housing. Detector switching takes place whenever an opaque object passes through the slot between emitter and detector. The side mounting package is useful in applications in which the interruptive element is parallel to the mounting plane. Both emitter and detector have a 0.010 in.(0.25 mm) x 0.60 in(1.52 mm) vertical aperture. This feature is ideal for use in applications in which maximum position resolution is desired.

All devices employ a built-in strain relief for maximum wire attachment strength. The sensor housing contains IR transmissive optical windows. This arrangement provides excellent protection against ambient light while eliminating aperture openings which could be clogged by airborne contaminants. The HOA1887 series contains plastic molded components. For additional component information see SEP8506, SDP8406, and SDP8106.

Housing material is polycarbonate. Housings are soluble in chlorinated hydrocarbons and ketones. Recommended cleaning agents are methanol and isopropanol.

Wire color and functions are:

- Red - IRED Anode
- Black - IRED Cathode
- White - Detector Collector

OUTLINE DIMENSIONS in inches (mm)

Tolerance 3 plc decimals ±0.010(0.25)
2 plc decimals ±0.020(0.51)

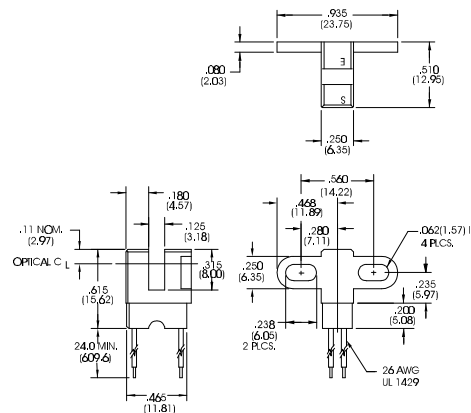

HOA1887

Transmissive Sensor

ELECTRICAL CHARACTERISTICS (25°C unless otherwise noted)

PARAMETER	SYMBOL	MIN	TYP	MAX	UNITS	TEST CONDITIONS
IR EMITTER						
Forward Voltage	V_F			1.6	V	$I_F=20\text{ mA}$
Reverse Leakage Current	I_R			10	μA	$V_R=3\text{ V}$
DETECTOR						
Collector-Emitter Breakdown Voltage HOA1887-011, -012 HOA1887-013	$V_{(BR)CEO}$	30 15			V	$I_C=100\ \mu\text{A}$
Emitter-Collector Breakdown Voltage	$V_{(BR)ECO}$	5.0			V	$I_E=100\ \mu\text{A}$
Collector Dark Current HOA1887-011, -012 HOA1887-013	I_{CEO}			100 250	nA	$V_{CE}=10\text{ V}$ $I_F=0$
COUPLED CHARACTERISTICS						
On-State Collector Current HOA1887-011 HOA1887-012 HOA1887-013	$I_{C(ON)}$	0.3 1.8 4.0			mA	$V_{CE}=5\text{ V}$ $I_F=20\text{ mA}$
Collector-Emitter Saturation Voltage HOA1887-011 HOA1887-012 HOA1887-013	$V_{CE(SAT)}$			0.4 0.4 1.1	V	$I_F=20\text{ mA}$ $I_C=40\ \mu\text{A}$ $I_C=230\ \mu\text{A}$ $I_C=500\ \mu\text{A}$
Rise And Fall Time HOA1887-011, -012 HOA1887-013	t_r, t_f			15 75	μs	$V_{CC}=5\text{ V}, I_C=1\text{ mA}$ $R_L=1000\ \Omega$ $R_L=100\ \Omega$

ABSOLUTE MAXIMUM RATINGS

(25°C Free-Air Temperature unless otherwise noted)

Operating Temperature Range -40°C to 85°C

Storage Temperature Range -40°C to 85°C

Soldering Temperature (5 sec) 240°C

IR EMITTER

Power Dissipation 100 mW ⁽¹⁾

Reverse Voltage 3 V

Continuous Forward Current 50 mA

DETECTOR

Collector-Emitter Voltage 30 V TRANS. 15 V DARLINGTON

Emitter-Collector Voltage 5 V 5 V

Power Dissipation 100 mW ⁽¹⁾ 100 mW ⁽¹⁾

Collector DC Current 30 mA 30 mA

SCHEMATIC

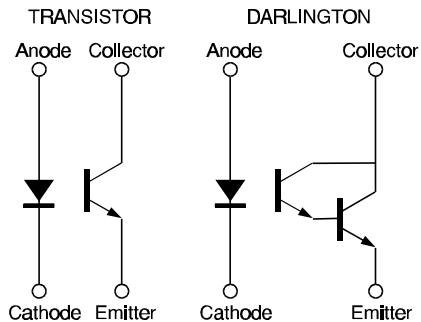

Honeywell reserves the right to make changes in order to improve design and supply the best products possible.

Honeywell

HOA1887

Transmissive Sensor

Fig. 1 IRED Forward Bias Characteristics

gra_092.ds4

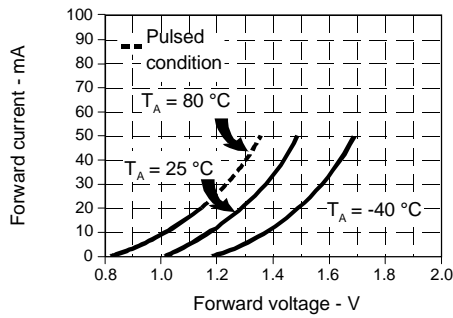

Fig. 2 Non-Saturated Switching Time vs Load Resistance

gra_096.ds4



Fig. 3 Detector Dark Current vs Temperature

gra_094.ds4

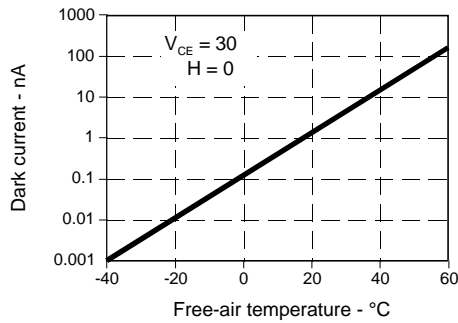

Fig. 4 Collector Current vs Ambient Temperature

gra_095.ds4



All Performance Curves Show Typical Values

HOA1887
Transmissive Sensor

Honeywell reserves the right to make changes in order to improve design and supply the best products possible.

Honeywell

341