



GENERAL DESCRIPTION



The ICS83840B is a DDR SDRAM MUX and is a member of the HiPerClockS™ family of High Performance Clock Solutions from ICS. The device has 10 Host Lines and each host line can be passed to 4 Data Ports. The 10 channels are allocated as follows in the DDR SDRAM application: 8 data lines, 1 strobe line and 1 DQm line. The Host/Data Ports are compatible with single-ended SSTL-2 and the device operates from a 2.5V supply.

Guaranteed low output skew makes the ICS83840B ideal for demanding applications which require well defined performance and repeatability.

SIMPLIFIED SCHEMATIC

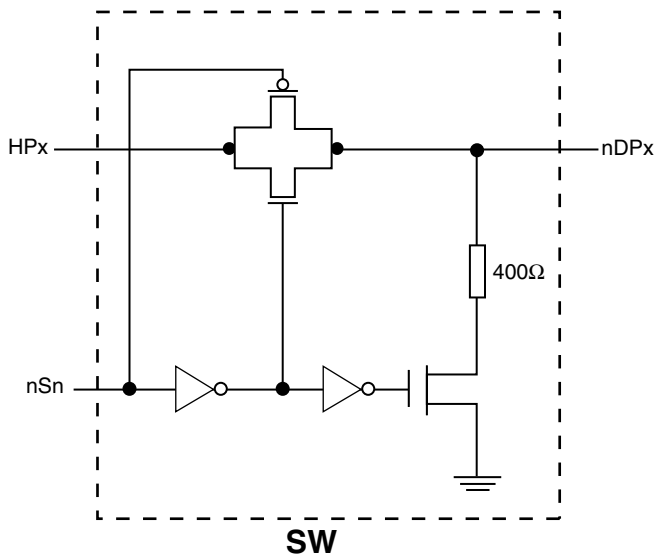

FEATURES

- 40 low skew single-ended DIMM ports
- 4 SSTL-2 compatible enable inputs
- Maximum Switching Speed: 3ns
- Output skew: 120ps (maximum)
- Bank skew: 60ps (maximum)
- $r_{on} = 8\Omega$ (typical)
- Full 2.5V supply modes
- 0°C to 70°C ambient operating temperature
- Pin compatible with the CBTV4010

LOGIC DIAGRAM

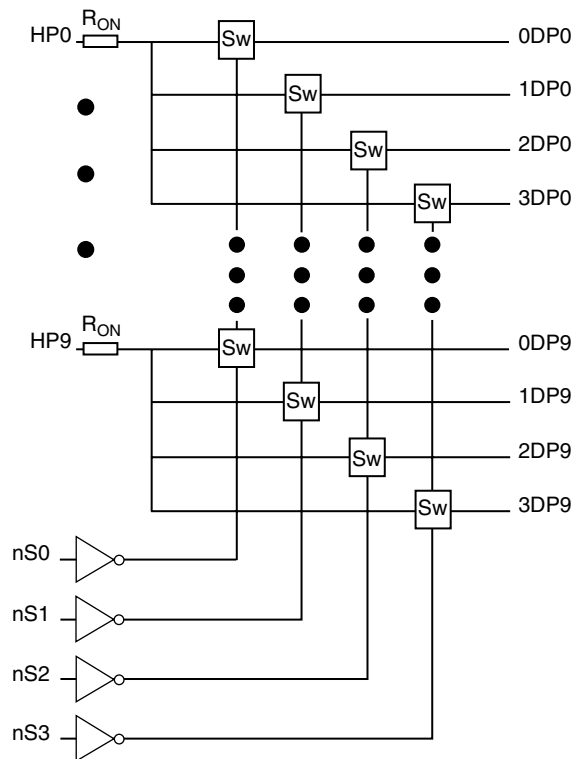

PIN ASSIGNMENT

	1	2	3	4	5	6	7	8	9	10	11
A	V _{DD}	nS1	nc		1DP0	2DP0	3DP0		2DP1	3DP1	ODP2
B	nS2	V _{DD}	nS0	GND	ODP0	HP0	ODP1	1DP1	HP1	GND	1DP2
C	nc	nS3								HP2	2DP2
D		GND								3DP2	
E	2DP9	3DP9								ODP3	1DP3
F	1DP9	HP9								HP3	2DP3
G	ODP9	3DP8								GND	3DP3
H		2DP8								ODP4	
J	1DP8	HP8								HP4	1DP4
K	ODP8	GND	HP7	ODP7	3DP6	HP6	GND	3DP5	HP5	3DP4	2DP4
L	3DP7	2DP7	1DP7		2DP6	1DP6	ODP6		2DP5	1DP5	ODP5

ICS83840B
64-Ball TFBGA
7mm x 7mm x 1.2mm
package body
H Package
Top View



TABLE 1. PIN DESCRIPTIONS

Number	Name	Type	Description
A1, B2	V _{DD}	Power	Positive supply pins.
B4, B10, D2, G10, K2, K7	GND	Power	Power supply ground.
A3, C1	nc	Unused	No connect.
A2, B1, C2, B3	nS1, nS2, nS3, nS0	Port	Select pins.
B6, B9, C10, F2, F10, J2, J10, K3, K6, K9	HP0, HP1, HP2, HP9, HP3, HP8, HP4, HP7, HP6, HP5	Port	Host ports.
A5, A6, A7, B5	1DP0, 2DP0, 3DP0, 0DP0	Port	DIMM ports.
A9, A10, B7, B8	2DP1, 3DP1, 0DP1, 1DP1	Port	DIMM ports.
A11, B11, C11, D10	0DP2, 1DP2, 2DP2, 3DP2	Port	DIMM ports.
E10, E11, F11, G11	0DP3, 1DP3, 2DP3, 3DP3	Port	DIMM ports.
H10, J11, K10, K11	0DP4, 1DP4, 3DP4, 2DP4	Port	DIMM ports.
K8, L9, L10, L11	3DP5, 2DP5, 1DP5, 0DP5	Port	DIMM ports.
K5, L5, L6, L7	3DP6, 2DP6, 1DP6, 0DP6	Port	DIMM ports.
K4, L1, L2, L3	0DP7, 3DP7, 2DP7, 1DP7	Port	DIMM ports.
G2, H2, J1, K1	3DP8, 2DP8, 1DP8, 0DP8	Port	DIMM ports.
E1, E2, F1, G1	2DP9, 3DP9, 1DP9, 0DP9	Port	DIMM ports.

TABLE 2. PIN CHARACTERISTICS

Symbol	Parameter	Test Conditions	Minimum	Typical	Maximum	Units
C _{IN}	Input Capacitance	nSx	V _I = 0V or V _{DD}		5	pF
C _{ON}	Channel on Capacitance	HPx	V _{IN} = 1.5V		14	pF

NOTE: Capacitance values are measured at 10MHz and a bias voltage 3V. Capacitance is not production tested.

TABLE 3. FUNCTION TABLE

Control Input	Function
nSx	
L	Host Port = DIMM Port
H	Host Port = Disconnected DIMM Port = 400Ω to GND



ABSOLUTE MAXIMUM RATINGS

Supply Voltage, V_{DD}	-0.5V to +3.3V
Inputs, V_i	-0.3V to $V_{DD} + 0.3V$
Ports	
DC Input Clamp Current, I_{IK}	-50mA
Package Thermal Impedance, θ_{JA}	50.04°C/W (0 mfps)
Storage Temperature, T_{STG}	-65°C to 150°C

NOTE: Stresses beyond those listed under Absolute Maximum Ratings may cause permanent damage to the device. These ratings are stress specifications only. Functional operation of product at these conditions or any conditions beyond those listed in the *DC Characteristics* or *AC Characteristics* is not implied. Exposure to absolute maximum rating conditions for extended periods may affect product reliability.

TABLE 4A. POWER SUPPLY DC CHARACTERISTICS, $V_{DD} = 2.5V \pm 0.2V$, $T_A = 0^\circ C$ TO $70^\circ C$

Symbol	Parameter	Test Conditions	Minimum	Typical	Maximum	Units
V_{DD}	Positive Supply Voltage		2.3	2.5	2.7	V
I_{DD}	Power Supply Current				50	μA

TABLE 4B. DC CHARACTERISTICS, $V_{DD} = 2.5V \pm 0.2V$, $T_A = 0^\circ C$ TO $70^\circ C$

Symbol	Parameter	Test Conditions	Minimum	Typical	Maximum	Units
V_{IH}	Input High Voltage	nSx	1.6			V
V_{IL}	Input Low Voltage	nSx			0.9	V
V_{IK}	Input Clamp Voltage	$V_{DD} = 2.3V$; $I_i = -18mA$			-1.2	V
I_L	Input Leakage Current	nSx	$V_{DD} = 2.5V$; $V_i = V_{DD}$ or GND; $nS = V_{DD}$		± 100	μA
		Host Port				
		DIMM Port				
r_{ON}	On Resistance; NOTE 1	$V_{DD} = 2.5V$; $V_A = 0.8V$; $V_B = 1.0V$	5	8	13	Ω
		$V_{DD} = 2.5V$; $V_A = 1.7V$; $V_B = 1.5V$	5	8	13	Ω

NOTE 1: Calculated from the current measure, between the Host and the DIMM terminals at the indicated voltages on each side of the switch.

TABLE 5. AC CHARACTERISTICS, $V_{DD} = 2.5V \pm 0.2V$, $T_A = 0^\circ C$ TO $70^\circ C$

Symbol	Parameter	Test Conditions	Minimum	Typical	Maximum	Units
t_{PD}	Propagation Delay; NOTE 1, 4	From HPx or xDPx to xDPx or HPx	80	160	250	ps
t_{EN}	Output Enable Time	From nSx to HPx or nDPx	1.2			ns
t_{DIS}	Output Disable Time	From nSx to HPx or nDPx	1.2			ns
t_{OSK}	Output Skew; NOTE 2, 4	Any Port to any Port			120	ps
t_{BSK}	Bank Skew; NOTE 3, 4	Any Port to any Port within the same bank			60	ps

NOTE 1: Measured from $V_{DD}/2$ of the input to $V_{DD}/2$ of the output.

NOTE 2: Defined as skew between outputs at the same supply voltage and with equal load conditions. Measured at $V_{DD}/2$.

NOTE 3: Defined as skew within a bank with equal load conditions.

NOTE 4: Not production tested, guaranteed by characterization.



PARAMETER MEASUREMENT INFORMATION

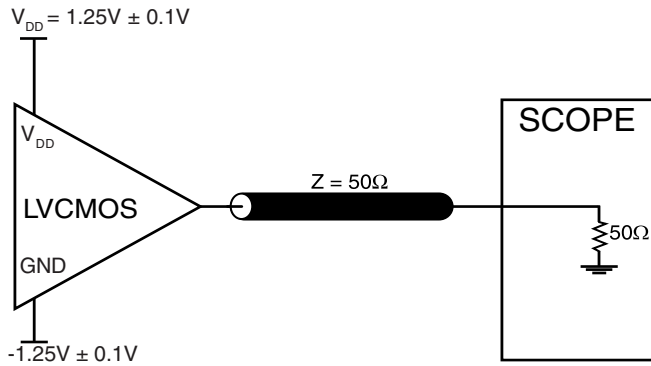

This circuit is used for test purposes only,
not intended for application use.

2.5V OUTPUT LOAD AC TEST CIRCUIT

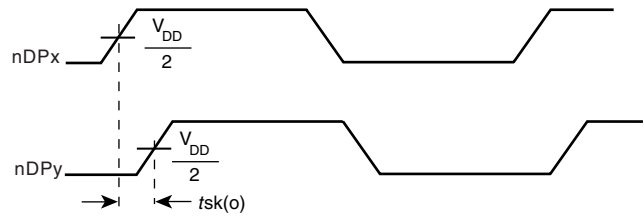

OUTPUT SKEW

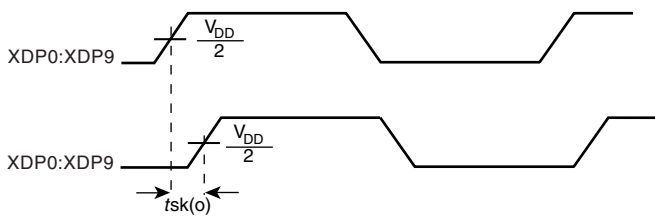

BANK SKEW (where X denotes outputs in the same bank)

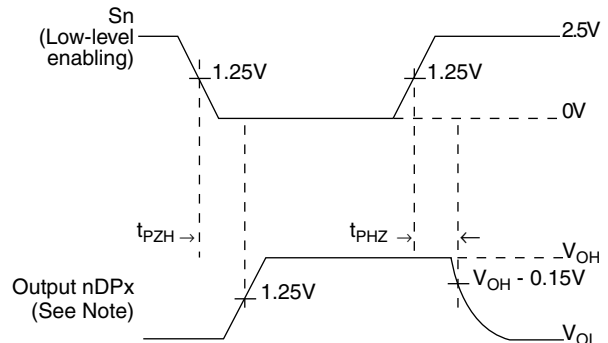

NOTE: The output is high except when disabled by the Sn control.

3-STATE OUTPUT ENABLE/DISABLE TIMES

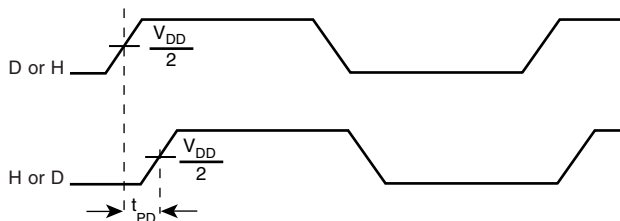

PROPAGATION DELAY



RELIABILITY INFORMATION

TABLE 6. θ_{JA} VS. AIR FLOW TABLE

θ_{JA} by Velocity (Millimeter Feet per Second)			
	0	1	2
Two-Layer PCB, JEDEC Standard Test Boards	50.04°C/W	43.18°C/W	41.17°C/W

NOTE: Most modern PCB designs use multi-layered boards. The data in the second row pertains to most designs.

TRANSISTOR COUNT

The transistor count for ICS83840B is: 320



PACKAGE OUTLINE - H SUFFIX

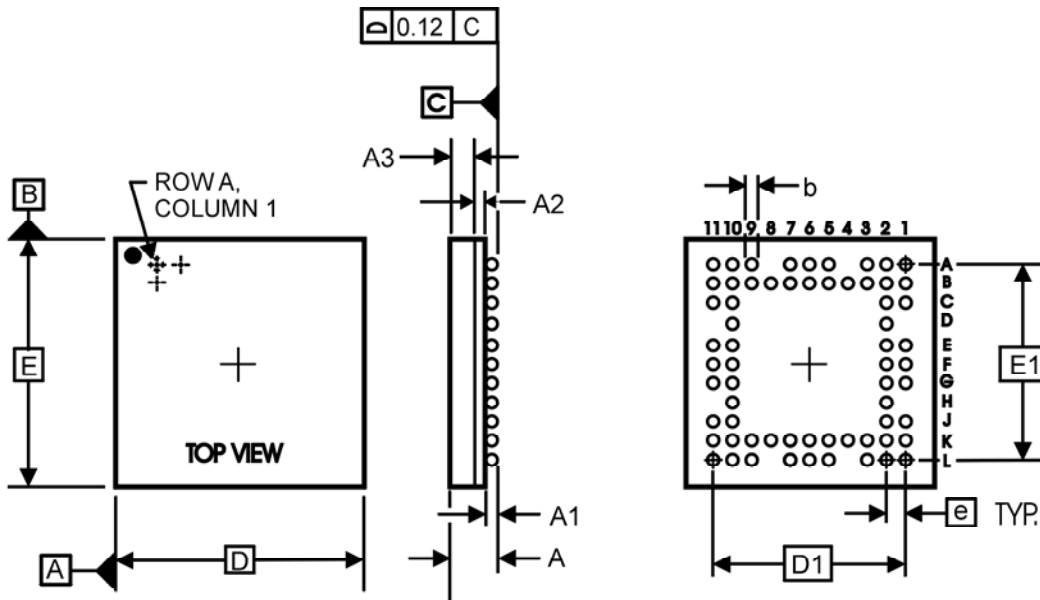

TABLE 7. PACKAGE DIMENSIONS

JEDEC VARIATION ALL DIMENSIONS IN MILLIMETERS			
SYMBOL	FBGA		
	MINIMUM	NOMINAL	MAXIMUM
64 Balls, 7x7mm, 11x11 Pattern			
A	1.0	1.1	1.2
A1	0.165	0.2	0.235
A2	0.16	0.2	0.24
A3	0.675	0.7	0.725
b	0.25	0.3	0.35
D	7.00 BSC		
D1	5.00 BSC		
E	7.00 BSC		
E1	5.00 BSC		
e	0.50 BSC		

REFERENCE DOCUMENT: JEDEC PUBLICATION 95



Integrated
Circuit
Systems, Inc.

ICS83840B

DDR SDRAM MUX

TABLE 8. ORDERING INFORMATION

Part/Order Number	Marking	Package	Count	Temperature
ICS83840BH	ICS83840BH	64-Ball TFBGA	416 per tray	0°C to 70°C
ICS83840BHT	ICS83840BH	64-Ball TFBGA on Tape and Reel	1000	0°C to 70°C
ICS83840BHLF	ICS3840BLF	64-Ball, Lead Free, TFBGA	416 per tray	0°C to 70°C
ICS83840BHLFT	ICS3840BLF	64-Ball, Lead Free, TFBGA on Tape and Reel	1000	0°C to 70°C

While the information presented herein has been checked for both accuracy and reliability, Integrated Circuit Systems, Incorporated (ICS) assumes no responsibility for either its use or for infringement of any patents or other rights of third parties, which would result from its use. No other circuits, patents, or licenses are implied. This product is intended for use in normal commercial applications. Any other applications such as those requiring extended temperature range, high reliability, or other extraordinary environmental requirements are not recommended without additional processing by ICS. ICS reserves the right to change any circuitry or specifications without notice. ICS does not authorize or warrant any ICS product for use in life support devices or critical medical instruments.