

LMX4168 Radio Transceiver for DECT

1.0 General description

The LMX4168 is a radio transceiver integrated circuit optimized for the Digital Enhanced Cordless Telecommunications (DECT) system. The transceiver, when combined with a power amplifier and a Tx/Rx switch, implements a complete DECT radio transceiver compliant with the ETSI CTR6 standard. The LMX4168 interfaces to National Semiconductor's SC144XX DECT family of baseband processors.

The LMX4168 integrates a complete transmitter, consisting of a phase locked loop, VCO and PA driver. The receiver contains LNA, quadrature downconverter, polyphase filter/combiner, automatic gain control, and demodulator. The LMX4168 operates from a single 2.25–2.75V supply. The LMX4168 is manufactured in National's 0.25µm CMOS technology, and is packaged in a 44 pin LLP package

2.0 Features

- Highly integrated 1.9 GHz low-IF CMOS transceiver
- Down conversion to half the DECT channel spacing (864 kHz)
- On-chip channel select filter
- On-chip Voltage Controlled Oscillator (VCO)
- On-chip low noise amplifier (LNA)
- Open-loop modulation
- On-chip timing control
- Four digital (5 mA) output ports
- 0 dBm PA driver output
- -95 dBm sensitivity
- 2.5V operation
- Small 44 pin Leadless Leadframe Package

3.0 Applications

- (DECT) Digital Enhanced Cordless Telecommunications

4.0 System Diagram

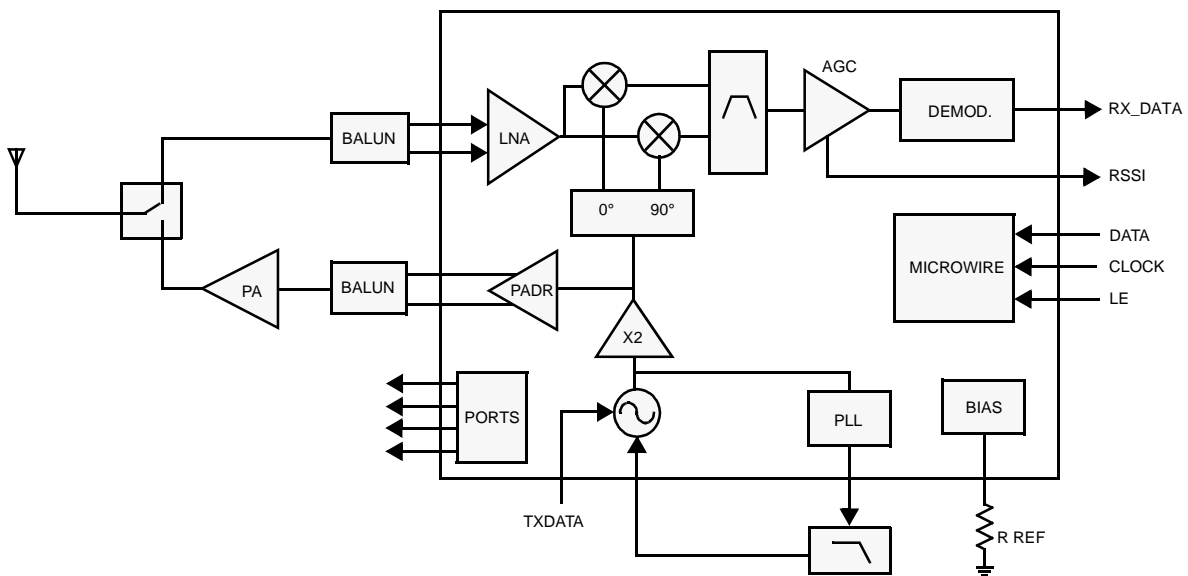

5.0 Specifications

5.1 ABSOLUTE MAXIMUM RATINGS

Table 1. Absolute Maximum Ratings¹

Parameter	Description	Value			Unit
		Min	Typ	Max	
Vdd_max	Power supply voltage (Vdd_ADC, Vdd_IF, Vdd_mix, Vdd_LNA, Vdd_ESD, Vdd_PAdr, Vdd_presc, Vdd_PLL, Vdd_VCO, Vdd_shield, Vdd_bias, Vdd_dig, Vdd_RSSI)	-0.3		3.0	V
	Absolute difference between power supplies			0.3	V
V _n	Voltage on any pin	-0.3		Vdd+0.3	V
P _{in}	Input power (at pins Rxin, RxinZ)			+15	dBm
T _S	Storage temperature	-65		+150	°C
T _L	Lead temperature (solder 4 sec)			+ 260	°C
V _{HBM}	ESD - human body model ²			2	kV
V _{MM}	ESD - machine model ²			250	V

1. Absolute Maximum Ratings indicate limits beyond which damage to the device may occur. Operating Ratings indicate conditions for which the device is intended to be functional, but do not guarantee specific performance limits. For guaranteed specifications and test conditions, see the Electrical Characteristics. The guaranteed specifications apply only to the test conditions listed.
2. MSL 2 (Moisture Sensitivity Level) is valid when the standard reflow process (235°C) is used. MSL 2 means 1 year shelf life after opening dry-pack. MSL 2(1 year shelf life) is also valid when the lead free reflow process (260°C) is used. Storage conditions are max. 30°C / 60% rel. humidity.

5.2 ELECTRICAL CHARACTERISTICS

Table 2. Recommended Operating Conditions

Parameter	Description	Value			Unit
		Min	Typ	Max	
Vdd	Power supply voltage (Vdd_ADC, Vdd_IF, Vdd_mix, Vdd_LNA, Vdd_ESD, Vdd_PAdr, Vdd_presc, Vdd_PLL, Vdd_VCO, Vdd_shield, Vdd_bias, Vdd_dig, Vdd_RSSI)	2.25	2.5	2.75	V
V _{TXoutZ} , V _{TXout}	PA driver output biasing voltage @ pins 16 and 17			2.0	V
T _A	Operating temperature	-10		+60	°C
Rref	Reference resistor connected from pin 31 to Vss	60	62	64	kΩ

6.0 Product Status Definitions

Datasheet Status	Product Status	Definition
Advance Information	Formative or in Design	This data sheet contains the design specifications for product development. Specifications may change in any manner without notice.
Preliminary	First Production	This data sheet contains preliminary data. Supplementary data will be published at a later date. National Semiconductor Corporation reserves the right to make changes at any time without notice in order to improve design and supply the best possible product.
No Identification Noted	Full production	This data sheet contains final specifications. National Semiconductor Corporation reserves the right to make changes at any time without notice in order to improve design and supply the best possible product.
Obsolete	Not in Production	This data sheet contains specifications on a product that has been discontinued by National Semiconductor Corporation. The datasheet is printed for reference information only.

7.0 Package Information inches (millimeters) unless otherwise noted

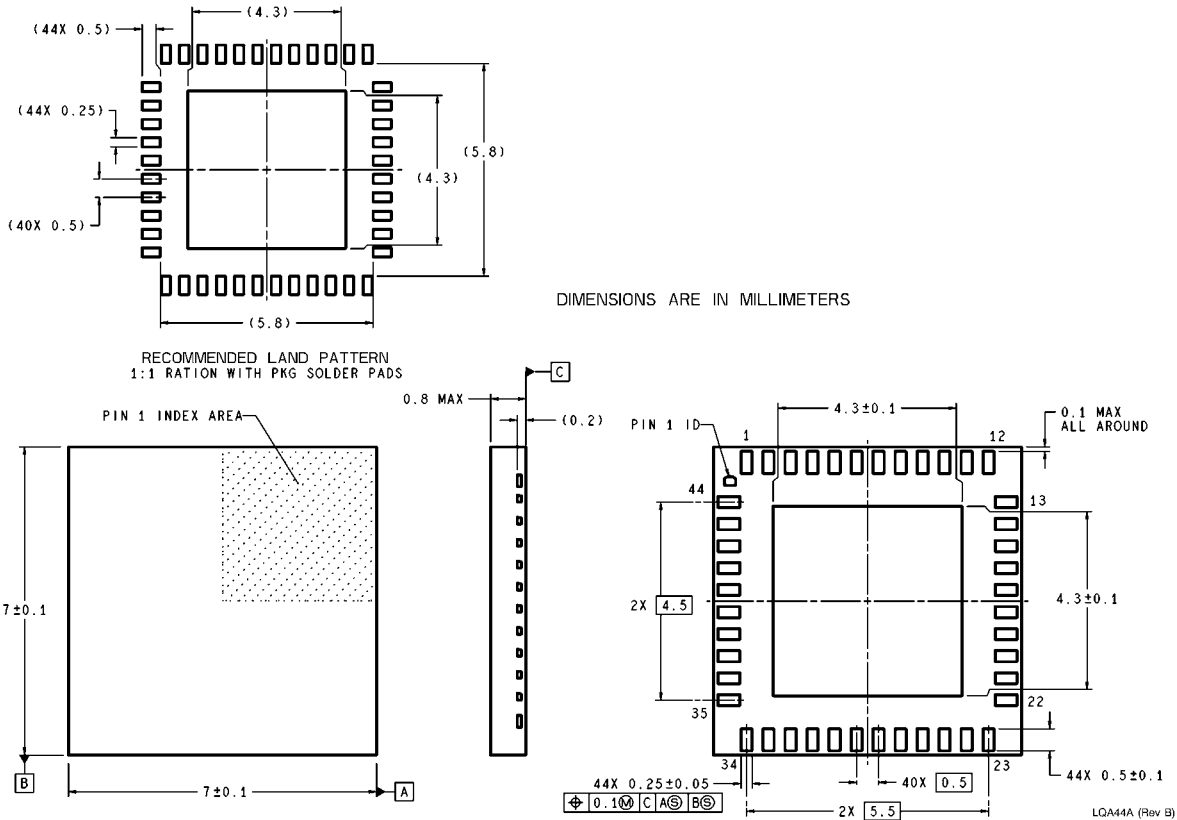

Order Number For Tray LMX4168FLQ, xx units per Tray, xx Trays per Shipment Box.

Order Number For Tape/Reel LMX4168FLQx, xxxx units per Tape/Reel, 1 Reel per Shipment Box

44 pins Leadless Leadframe Package. NS Package Number LQA044AF

Note: MSL 2 (Moisture Sensitivity Level) is valid when the standard reflow process (235°C) is used. MSL 2 = 1 year - after opening dry-pack. Storage conditions are max 30°C / 60% rel humidity.

Note: Refer to the application note AN-1187 for relevant soldering information.
This document can be downloaded from <http://www.national.com/an/AN/AN-1187.pdf>

LIFE SUPPORT POLICY

NATIONAL'S PRODUCTS ARE NOT AUTHORIZED FOR USE AS CRITICAL COMPONENTS IN LIFE SUPPORT DEVICES OR SYSTEMS WITHOUT THE EXPRESS WRITTEN APPROVAL OF THE PRESIDENT AND GENERAL COUNSEL OF NATIONAL SEMICONDUCTOR CORPORATION. As used herein:

- Life support devices or systems are devices or systems which, (a) are intended for surgical implant into the body, or (b) support or sustain life, and whose failure to perform, when properly used in accordance with instructions for use provided in the labeling, can be reasonably expected to result in a significant injury to the user.
- A critical component is any component of a life support device or system whose failure to perform can be reasonably expected to cause the failure of the life support device or system, or to affect its safety or effectiveness.

BANNED SUBSTANCE COMPLIANCE

National Semiconductor certifies that the products and packing materials meet the provisions of the Customer Products Stewardship Specification (CSP-9-111C2) and the Banned Substances and Materials of Interest Specification (CSP-9-111S2) and contain no "Banned Substances" as defined in CSP-9-111S2.



National Semiconductor Corporation
Tel: 1-800-272-9959
Fax: 1-800-737-7018
Email: support@nsc.com

National Semiconductor Europe
Fax: +49 (0) 180-530 85 86
Email: europe.support@nsc.com
Deutsch Tel: +49 (0) 69 9508 6208
English Tel: +44 (0) 870 24 0 2171
Francais Tel: +33 (0) 1 41 91 8790

National Semiconductor Asia Pacific Customer Response Group
Tel: 65-254-4466
Fax: 65-250-4466
Email: ap.support@nsc.com

National Semiconductor Japan Ltd.
Tel: 81-3-5639-7560
Fax: 81-3-5639-7507