

FEATURES

- 210 μ A typical current drain
- 4 inverting opamps; B with 6 dB greater drive current
- minimum 46 dB open loop gain
- ideal for - active filtering
 - dual channel hearing aids
 - mixers
 - microphone / telecoil preamps

STANDARD PACKAGING

- 10 pin PLID[®]
- 10 pin SLT
- Chip (61 x 55 mils)
 Au Bump

DESCRIPTION

The LX509 consists of 4 independent low noise, low current inverting operational amplifiers utilizing Gennum's low voltage bipolar JFET technology. Each amplifier has a minimum open loop gain of 46 dB with the closed loop gain set by the ratio of a feedback (R_f) resistor to the source impedance (R_s). For a well controlled gain tolerance from amplifier to amplifier, it is recommended that the closed loop gain is at least 20 dB below the open loop gain.

Three of the preamplifiers, A, C and D are capable of delivering typically 30 μ A of peak current drive while the fourth pre-amplifier B has 6 dB more current drive capability, allowing a 6 dB greater output into the same load impedance, or the same output level into one half the load impedance.

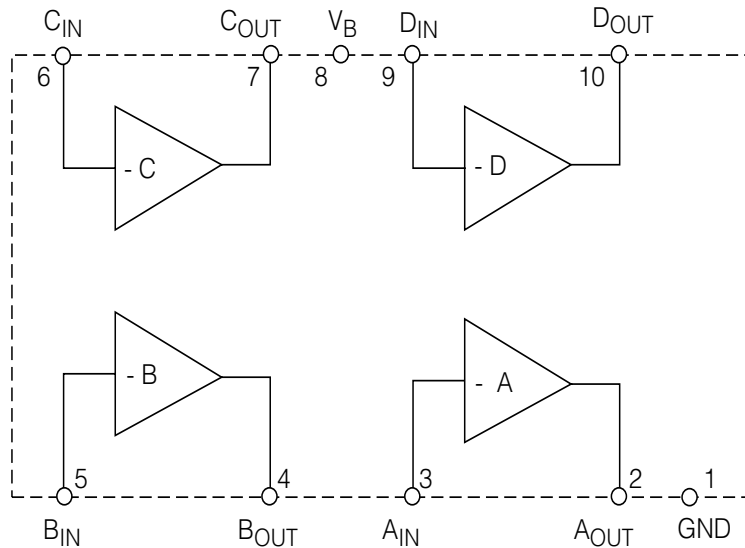

BLOCK DIAGRAM

ABSOLUTE MAXIMUM RATINGS

PARAMETER	VALUE / UNITS
Supply Voltage	5V DC
Operating Temperature	-10° to +40°C
Storage Temperature	-20° to +70°C

CAUTION
CLASS 1 ESD SENSITIVITY



PIN CONNECTION

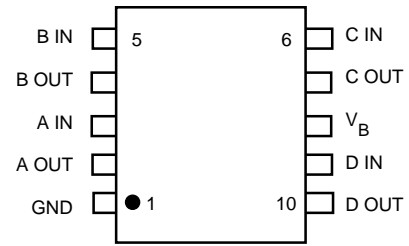

ELECTRICAL CHARACTERISTICS

V_{OUT} Pin voltage measured with conditions as shown in Test Circuit

Positive Current corresponds to current INTO the pin

Negative Current corresponds to current OUT of the pin

Conditions: Frequency = 1 kHz, Temperature = 25°C, Supply Voltage $V_B = 1.3$ VDC

PARAMETER	SYMBOL	CONDITIONS	MIN	TYP	MAX	UNITS
Total Current	I_{TOT}		115	210	305	μ A
Input Bias Voltage	V_{BIAS}		500	570	620	mVDC
Input Bias Current	I_{BIAS}	$R_F = 1 \text{ M}\Omega$	-50	0	50	nA
Output Voltage Swing - Hi	V_{OH}	$V_{IN} = 0.4 \text{ VDC}$, $R_F = \infty$ $I_L = -10 \mu\text{A}$, (Note 1)	200	580	-	mVDC
Output Voltage Swing - Lo	V_{OL}	$I_{IN} = +1 \mu\text{A}$, $R_F = \infty$ $I_L = +10 \mu\text{A}$, (Note 2)	200	280	-	mVDC
Open Loop Voltage Gain	A_{VOL}		46	56	-	dB
Input Referred Noise	IRN	NFB 0.2 to 10kHz at 12dB/Oct	-	1	-	μ V _{RMS}
Harmonic Distortion	THD		-	1	-	%
Current Drive		A, C, D,	-	30	-	μ A
Capability		B	-	60	-	μ A

All Parameters and Switches remain as shown in Test Circuit unless otherwise stated in "Conditions" Column

Notes: 1 $V_{OH} = V_{OUT} - V_{OUT}$ ($I_L = -10 \mu\text{A}$ for Blocks A, C, D, $I_L = -20 \mu\text{A}$ for Block B)

2 $V_{OL} = V_{OUT} - V_{OUT}$ ($I_L = +10 \mu\text{A}$ for Blocks A, C, D, $I_L = +20 \mu\text{A}$ for Block B)

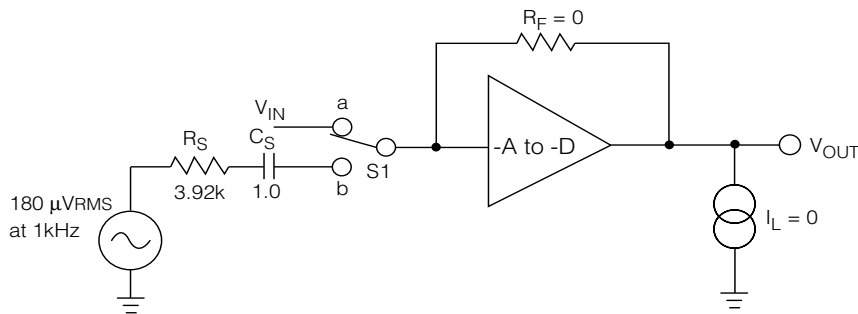

All resistors in ohms, all capacitors in μ F unless otherwise stated

Fig. 1 LX509 Test Circuit

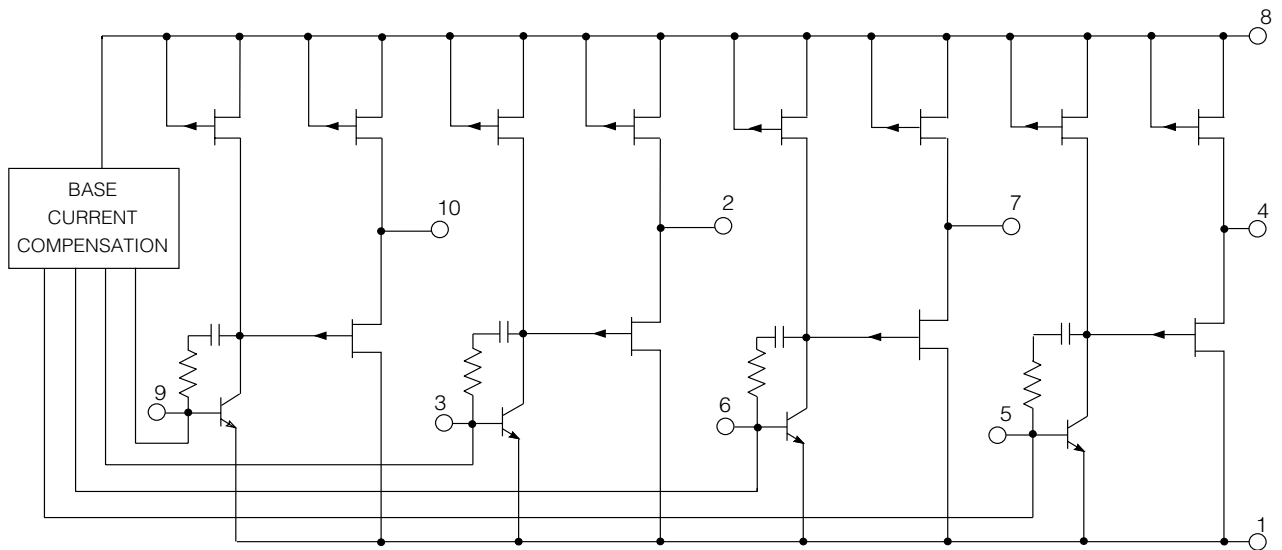

Fig. 2 Functional Schematic

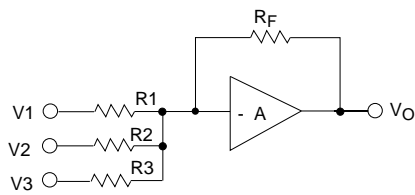

Fig. 3a Summing Amplifier

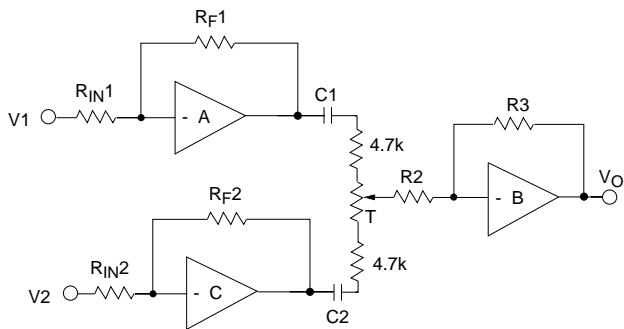

Fig. 3b Mixing Circuit

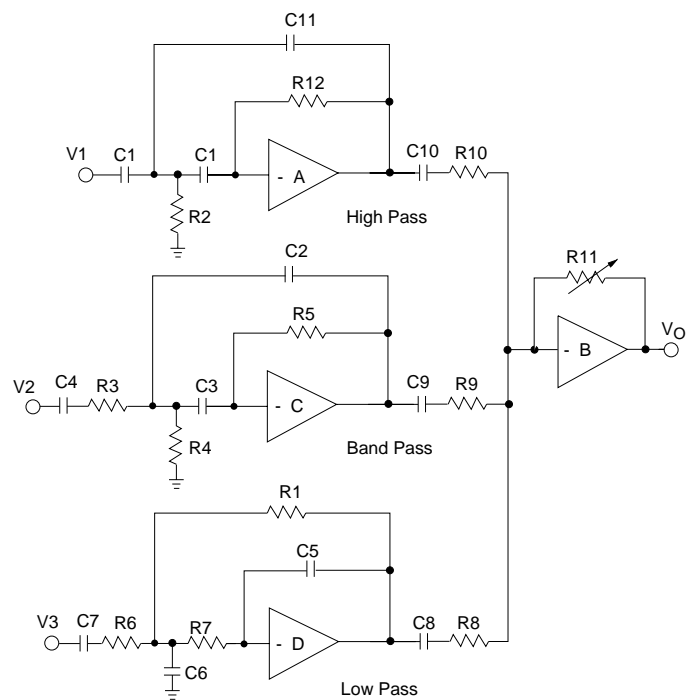

Fig. 3d Multi-Band Filtering

(for Filter Design refer to Note 600-9, Active Filtering for Hearing Aids)
All resistors in ohms, all capacitors in μF unless otherwise stated

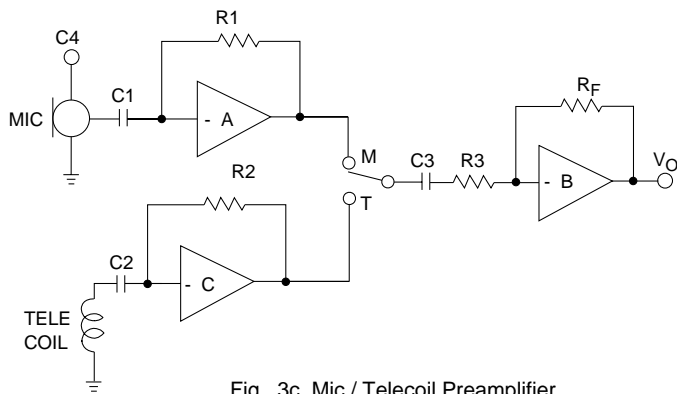

Fig. 3c Mic / Telecoil Preamplifier

Fig. 3 LX509 Application Circuits

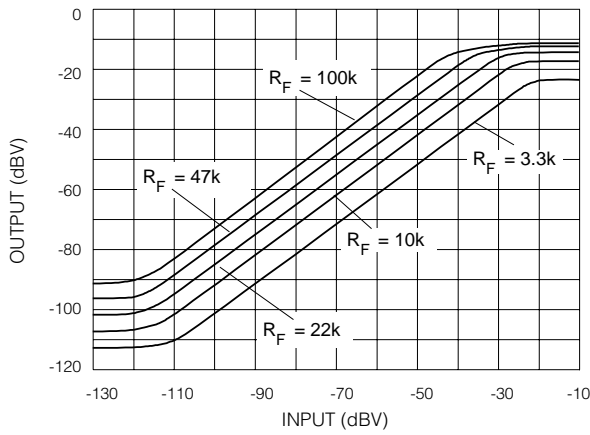

Fig. 4 I/O Characteristics for Various R_F Values

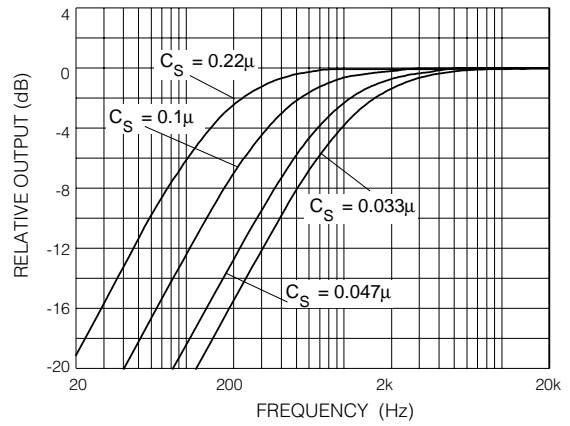

Fig. 5 Closed Loop Frequency Response for Various C_S Values

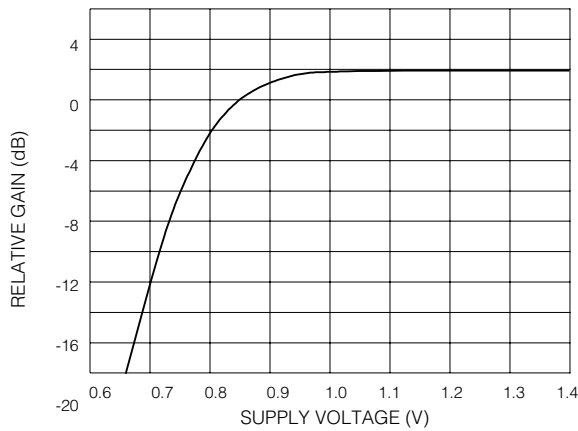

Fig. 6 Gain vs Supply Voltage

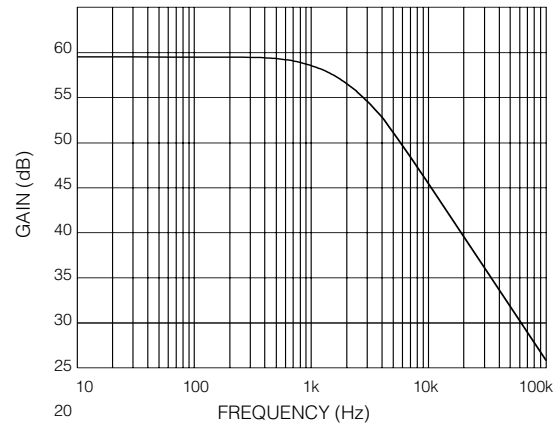

Fig. 7 Preamplifier Open Loop Frequency Response

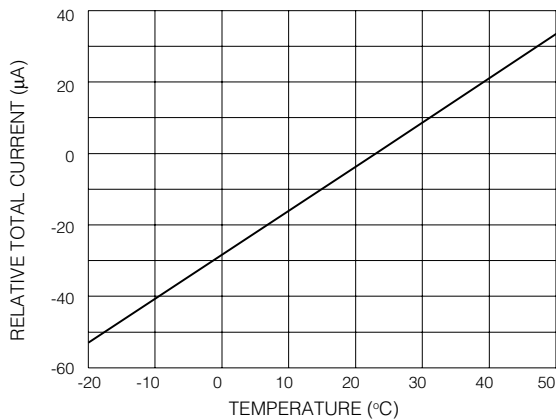

Fig.8 Total Current vs Temperature

GENNUM CORPORATION

MAILING ADDRESS:

P.O. Box 489, Stn. A, Burlington, Ontario, Canada L7R 3Y3
Tel. +1 (905) 632-2996 Fax +1 (905) 632-2814

SHIPPING ADDRESS:

970 Fraser Drive, Burlington, Ontario, Canada L7L 5P5

GENNUM JAPAN CORPORATION

C-101, Miyamae Village, 2-10-42 Miyamae, Suginami-ku, Tokyo 168-0081, Japan
Tel. +81 (3) 3334-7700 Fax: +81 (3) 3247-8839

DOCUMENT IDENTIFICATION: DATA SHEET

The product is in production. Gennum reserves the right to make changes at any time to improve reliability, function or design, in order to provide the best product possible.

REVISION NOTES:

Changes to standard packaging information.

Gennum Corporation assumes no responsibility for the use of any circuits described herein and makes no representations that they are free from patent infringement.

© Copyright July 1988 Gennum Corporation. All rights reserved.

Printed in Canada.