

L & S BAND GaAs FET [SMD non - matched]**DESCRIPTION**

The MGF0915A GaAs FET with an N-channel schottky Gate, is designed for use UHF band amplifiers.

FEATURES

- High output power
Po=36.5 dBm(TYP.) @f=1.9GHz,Pin=23dBm
- High power gain
Gp=14.5 dB(TYP.) @f=1.9GHz
- High power added efficiency
ηadd=50 %(TYP.) @f=1.9GHz,Pin=23dBm
- Hermetic Package

APPLICATION

- For UHF Band power amplifiers

QUALITY

- GG

RECOMMENDED BIAS CONDITIONS

- Vds=10V
- Ids=800 mA
- Rg=100Ω

Delivery -01:Tape & Reel(1K), -03:Trai(50pcs)

Absolute maximum ratings (Ta=25°C)

Symbol	Parameter	Ratings	Unit
VGSO	Gate to source breakdown voltage	-15	V
VGDO	Gate to drain breakdown voltage	-15	V
ID	Drain current	3000	mA
IGR	Reverse gate current	-10	mA
IGF	Forward gate current	21	mA
PT	Total power dissipation	18.7	W
Tch	Channel temperature	175	°C
Tstg	Storage temperature	-65 to +175	°C

Fig.1**Electrical characteristics** (Ta=25°C)

Symbol	Parameter	Test conditions	Limits			Unit
			Min.	Typ.	Max.	
IDSS	Saturated drain current	VDS=3V,VGS=0V	-	2400	3000	mA
VGS(off)	Gate to source cut-off voltage	VDS=3V,ID=10mA	-1	-3	-5	V
gm	Transconductance	VDS=3V,ID=800mA	-	1000	-	mS
Po	Output power	VDS=10V,ID=800mA,f=1.9GHz	35.0	36.5	-	dBm
ηadd	Power added Efficiency	Pin=23dBm	-	50	-	%
GLP	Linear Power Gain	VDS=10V,ID=800mA,f=1.9GHz	13.0	14.5	-	dB
Rth(ch-c)	Thermal Resistance *1	ΔVf Method	-	5	8	°C/W

*1:Channel to case / Above parameters, ratings, limits are subject to change.

MGF0915A TYPICAL CHARACTERISTICS

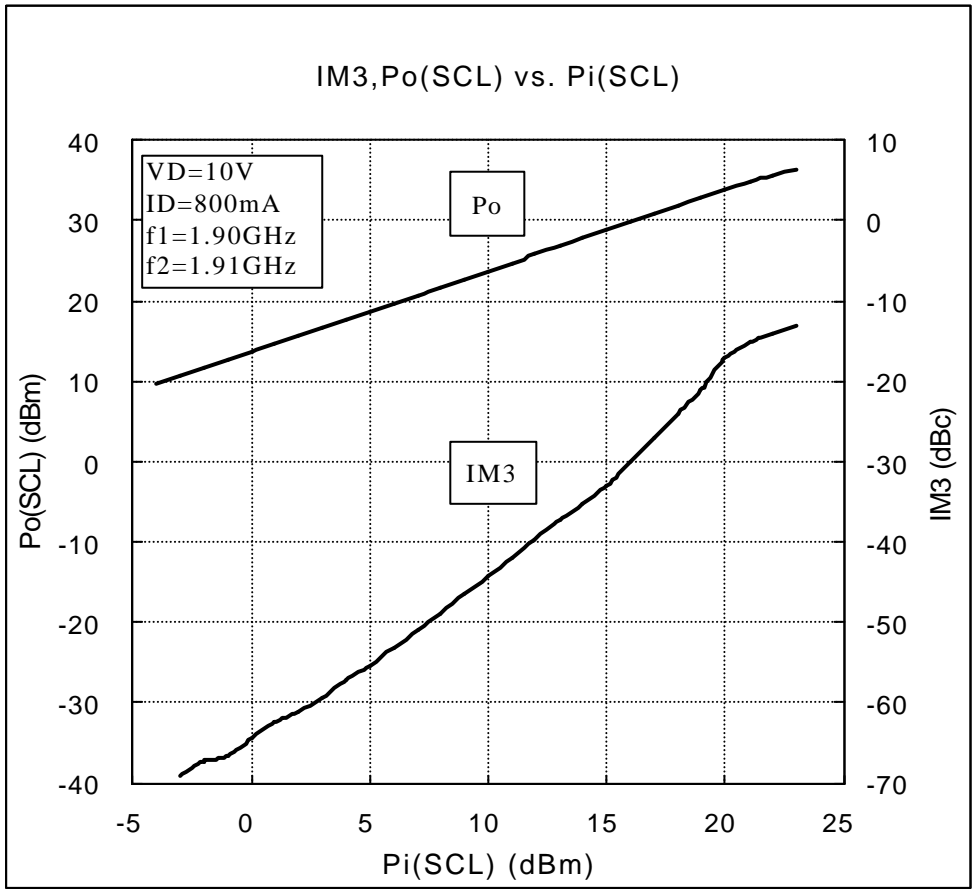
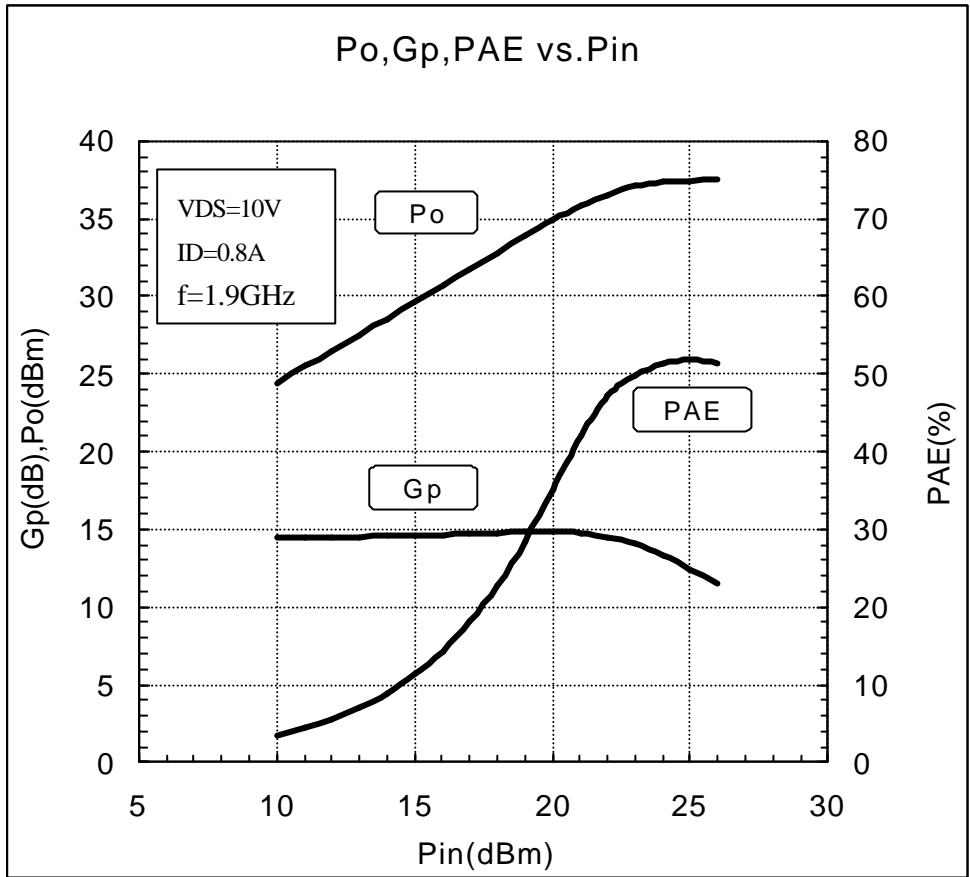

MGF0915A S PARAMETERS (Ta=25°C, VDS=10V, ID=800mA, Reference Plane see Fig.1)

freq. (MHz)	S11		S21		S12		S22		K	MAG/MSG (dB)
	(mag)	(ang)	(mag)	(ang)	(mag)	(ang)	(mag)	(ang)		
600	0.948	-145.92	4.852	99.38	0.013	24.42	0.721	-177.51	0.38	25.72
1000	0.947	-161.85	2.941	86.78	0.015	26.56	0.717	-178.09	0.63	22.92
1400	0.946	-168.94	2.144	77.11	0.015	28.76	0.719	-178.44	0.84	21.55
1800	0.946	-173.55	1.746	69.39	0.016	30.92	0.725	-178.66	0.94	20.38
2200	0.945	-176.72	1.456	62.91	0.017	32.93	0.732	-178.82	1.03	18.23
2600	0.944	-178.89	1.211	57.13	0.018	34.72	0.739	-178.94	1.14	16.00
3000	0.942	178.80	1.032	51.69	0.019	36.22	0.745	-179.06	1.27	14.25
3400	0.939	177.37	0.934	46.34	0.020	37.37	0.749	-179.19	1.34	13.19
3800	0.935	174.73	0.888	40.95	0.022	38.13	0.751	-179.32	1.34	12.59
4200	0.930	171.44	0.836	35.45	0.024	38.46	0.751	-179.44	1.38	11.75
4600	0.925	167.90	0.759	29.81	0.027	38.33	0.749	-179.56	1.43	10.58
5000	0.918	164.36	0.798	24.04	0.031	37.72	0.745	-179.67	1.27	10.96
5400	0.911	160.93	0.730	18.15	0.035	36.59	0.740	-179.78	1.33	9.76
5800	0.903	157.60	0.715	12.14	0.039	34.92	0.732	179.67	1.32	9.23
6200	0.894	154.31	0.708	6.01	0.045	32.68	0.724	177.54	1.26	8.90
6600	0.884	150.88	0.707	-0.28	0.052	29.84	0.713	175.25	1.20	8.65
7000	0.871	147.10	0.711	-6.80	0.060	26.34	0.702	172.45	1.15	8.38
7400	0.855	142.73	0.721	-13.66	0.069	22.15	0.688	169.39	1.12	8.06
7800	0.833	137.52	0.739	-20.98	0.081	17.18	0.671	166.53	1.09	7.75
8200	0.807	131.21	0.765	-28.93	0.094	11.37	0.651	164.20	1.08	7.43
8600	0.778	123.58	0.802	-37.70	0.110	4.61	0.624	162.51	1.04	7.36
9000	0.748	114.45	0.849	-47.48	0.129	-3.21	0.590	161.19	1.00	8.18
9400	0.717	103.71	0.905	-58.48	0.152	-12.23	0.545	159.72	0.96	7.75
9800	0.688	91.34	0.964	-70.88	0.179	-22.60	0.487	157.44	0.93	7.31
10200	0.671	77.41	1.023	-84.83	0.211	-34.51	0.410	153.88	0.90	6.86
10600	0.672	62.12	1.072	-100.40	0.248	-48.17	0.311	149.13	0.86	6.36
11000	0.697	45.82	1.100	-117.62	0.293	-63.82	0.184	144.37	0.81	5.75
11400	0.746	29.03	1.095	-136.37	0.326	-81.74	0.021	-179.00	0.79	5.26
11800	0.812	12.43	1.038	-156.40	0.346	-102.24	0.194	-81.10	0.79	4.77
12200	0.877	-3.09	0.913	-177.29	0.346	-125.67	0.404	-95.22	0.79	4.21

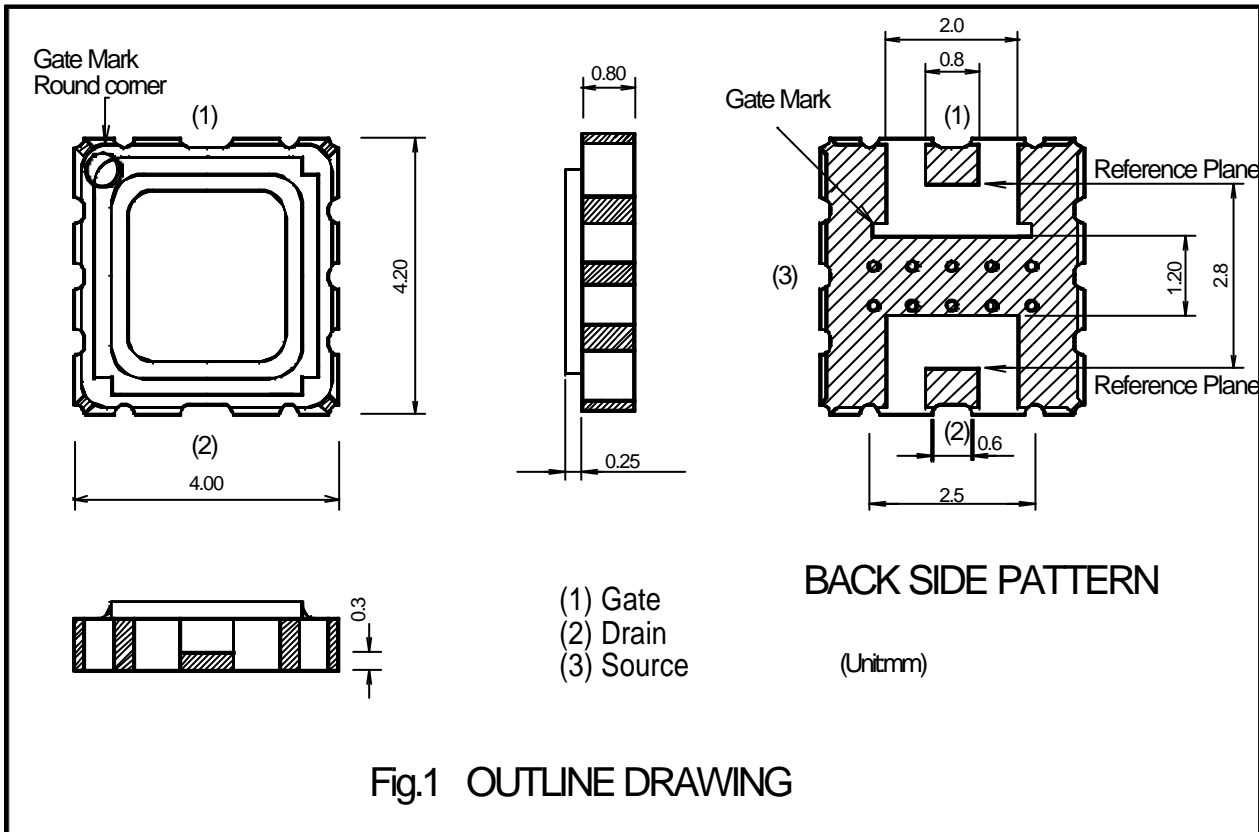

Fig.1 OUTLINE DRAWING