

General Description

The MIC2777 is a dual power supply supervisor that provides under-voltage monitoring, manual reset capability, and power-on reset generation in a compact 5-pin SOT package. Features include two under-voltage detectors, one fixed and one adjustable, and both active-high and active-low reset outputs. One under-voltage detector compares V_{DD} against a fixed threshold. Ten factory-programmed thresholds are available. The other under-voltage detector is user-adjustable.

The reset outputs are asserted for no less than 140ms at power-on and any time V_{DD} or the input voltage drops below the corresponding reference voltage. They remain asserted for the timeout period after the input voltage and V_{DD} subsequently rise back above the threshold boundaries. A reset can be generated at any time by pulling down on the adjustable input. Hysteresis is included to prevent chattering due to noise. Typical supply current is a low 3.5 μ A.

Features

- Monitors two independent power supplies for under-voltage conditions
- One fixed and one user adjustable input
- 1.5% threshold accuracy
- Choice of factory-programmed thresholds
- User-adjustable input can monitor supplies as low as 0.3V
- Generates 140ms (minimum) power-on RESET pulse
- Manual reset capability
- Both active-high and active-low RESET outputs
- Input may be pulled above V_{DD} (abs. max.)
- /RST output valid down to 1.2V
- Ultra-low supply current, 3.5 μ A typical
- Rejects brief input transients
- IttyBitty™ 5-lead SOT-23 package

Applications

- Monitoring processor, ASIC, or FPGA core and I/O voltages
- Computer systems
- PDAs, hand-held PCs
- Embedded controllers
- Telecommunications systems
- Power supplies
- Wireless / Cellular systems
- Networking hardware

Ordering Information

Part Number	Marking	Junction Temp. Range	Package
MIC2777-XXBM5	UNXX	-40°C to +85°C	SOT-23-5

Typical Application

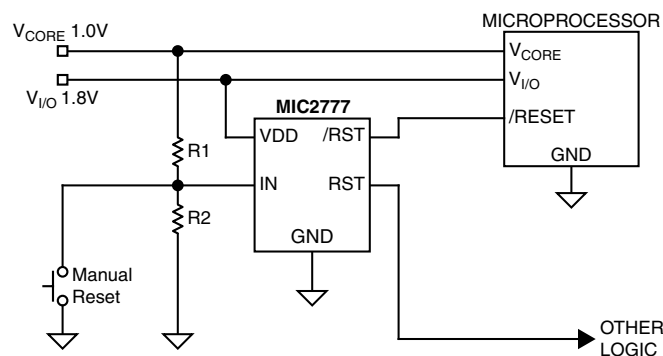

Typical Application

Standard Voltage Options*

Voltage Code	Typical Application (V_{DD})	Nominal Threshold Voltage (V_{TH})
46	5.0V \pm 5%	4.68
44	5.0V \pm 10%	4.43
31	3.3V \pm 5%	3.09
29	3.3V \pm 10%	2.93
28	3.0V \pm 5%	2.81
26	2.85V \pm 5%	2.67
25	2.70V \pm 5%	2.53
23	2.5V \pm 5%	2.34
22	2.4V \pm 5%	2.25
17	1.8V \pm 5%	1.69

*There are ten standard versions available with an order increment of 3000 pieces. Samples of standard versions are normally available from stock. Contact factory for information on non-standard versions. Available in tape-and-reel only.

Pin Configuration

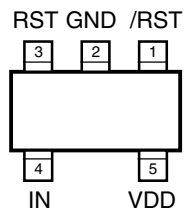

SOT-23-5 (M5)

Pin Description

Pin Number	Pin Name	Pin Function
1	/RST	Digital (Output): Asserted low whenever V_{IN} or V_{DD} falls below the reference voltage. It will remain asserted for no less than 140ms after V_{IN} and V_{DD} return above the threshold limits.
2	GND	Ground
3	RST	Digital (Output): Asserted high whenever V_{IN} or V_{DD} falls below the reference voltage. It will remain asserted for no less than 140ms after V_{IN} and V_{DD} return within above the threshold limit.
4	IN	Analog (Input): The voltage on this pin is compared to the internal 300mV reference. An undervoltage condition will trigger a reset sequence. Manual reset capability can be achieved by adding a switch between this pin and ground.
5	VDD	Analog (Input): Power supply input for internal circuitry and input to the fixed voltage monitor: The voltage on this pin is compared against the internal voltage reference. An undervoltage condition will trigger a reset sequence.

Absolute Maximum Ratings (Note 1)

Supply Voltage (V_{DD})	-0.3V to +7V
Input Voltage (V_{IN})	-0.3V to +7V
RST, (/RST) Current	20mA
Storage Temperature (T_S)	-65°C to +150°C
ESD Rating, Note 3	1.5kV

Operating Ratings (Note 2)

Supply Voltage (V_{DD})	+1.5V to +5.5V
Input Voltage (V_{IN})	-0.3V to +6.0V
Ambient Temperature Range (T_A)	-40°C to +85°C
Package Thermal Resistance (θ_{JA})	256°C/W

Electrical Characteristics

Note 5; $T_A = +25^\circ\text{C}$, **bold** values indicate $-40^\circ\text{C} \leq T_A \leq +85^\circ\text{C}$; unless noted

Symbol	Parameter	Condition	Min	Typ	Max	Units
I_{DD}	Supply Current	$V_{DD} = V_{IN}$ Note 5; /MR, RST, /RST open		3.5		μA
VDD VOLTAGE THRESHOLD						
	Under-Voltage Threshold On V_{DD}		$V_{TH-1.5\%}$	V_{TH}	$V_{TH+1.5\%}$	V
V_{HYST}	Hysteresis Voltage			1		%
IN, UNDER-VOLTAGE DETECTOR INPUT						
V_{REF}	Under-Voltage Threshold		295	300	305	mV
V_{HYST}	Hysteresis Voltage			3		mV
I_{IN}	Input Current			5		pA
		$T_{MIN} \leq T_A \leq T_{MAX}$			10	nA
RST, /RST OUTPUTS						
t_{PROP}	Propagation Delay	$V_{IN} = (V_{REF(MAX)} + 100\text{mV})$ to $V_{IN} = (V_{REF(MIN)} - 100\text{mV})$ or $V_{DD} = (V_{TH} + 2.5\%)$ to $(V_{TH} - 2.5\%)$, $V_{IN} = V_{DD}$		20		μs
t_{RST}	Reset Pulse Width		140		280	ms
V_{OL}	RST or /RST Output Voltage Low	$I_{SINK} = 1.6\text{mA}$; $V_{DD} \geq 1.6\text{V}$			0.3	V
		$I_{SINK} = 100\mu\text{A}$; $V_{DD} \geq 1.2\text{V}$, Note 4			0.3	V
V_{OH}	RST or /RST Output Voltage High	$I_{SOURCE} = 500\mu\text{A}$; $V_{DD} \geq 1.5\text{V}$	0.8	V_{DD}		V
		RST asserted, $I_{SOURCE} = 10\mu\text{A}$; $V_{DD} \geq 1.2\text{V}$, Note 4	0.8	V_{DD}		V

Note 1. Exceeding the absolute maximum rating may damage the device.

Note 2. The device is not guaranteed to function outside its operating rating.

Note 3. Devices are ESD sensitive. Handling precautions recommended. Human body model, 1.5k in series with 100pF.

Note 4. V_{DD} operating range is 1.5V to 5.5V. Output is guaranteed to be asserted down to $V_{DD} = 1.2\text{V}$.

Note 5. V_{DD} equals the nominal "Typical Application (V_{DD})" as shown in "Standard Voltage Options Table."

Timing Diagram

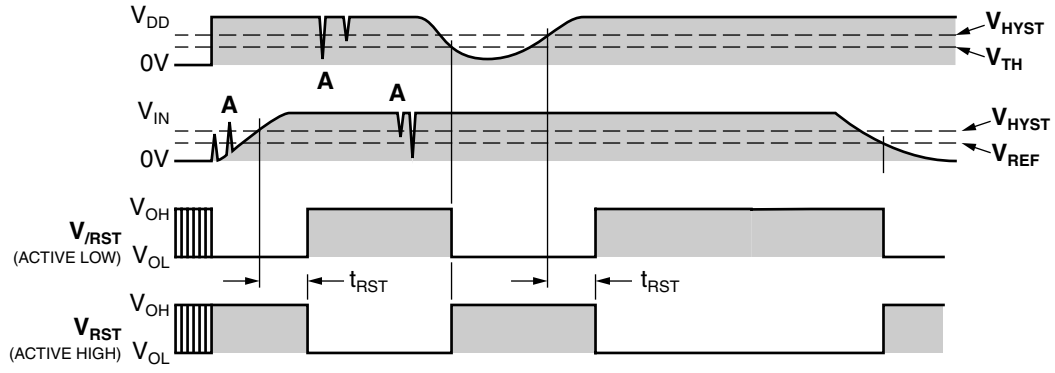

Propagation delays not shown for clarity.

Note A. The MIC2777 ignores very brief transients. See "Applications Information" for details.

Functional Diagram

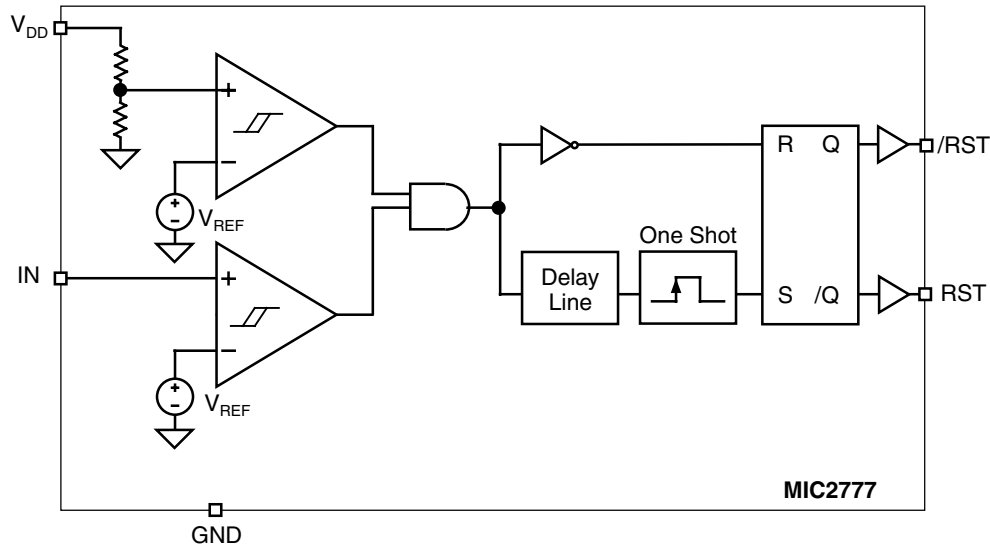

Functional Description

IN, Under-Voltage Detector Input

The voltage present at the IN pin is compared to the internal 300mV reference voltage. A reset is triggered if and when V_{IN} falls below V_{REF} . Typically, a resistor divider is used to scale the input voltage to be monitored such that V_{IN} will fall below V_{REF} as the voltage being monitored falls below the desired trip-point. Hysteresis is employed to prevent chattering due to noise. The comparator on the IN input is relatively immune to very brief negative-going transients.

V_{DD} Input

The V_{DD} pin is both the power supply terminal and a monitored input voltage. The voltage at this pin is continually compared against the internal reference. The trip-point at which a reset occurs is factory programmed. A reset is triggered if and when V_{DD} falls below the trip-point. Hysteresis is employed to prevent chattering due to noise. The comparator on the V_{DD} input is relatively immune to very brief negative-going transients.

RST, /RST Reset Output

Typically, the MIC2777 is used to monitor the power supplies of intelligent circuits such as microcontrollers and microprocessors. By connecting the appropriate reset output of a MIC2777 to the reset input of a μC or μP , the processor will be properly reset at power-on and during power-down and brown-out conditions.

The reset outputs are asserted any time V_{DD} or V_{IN} drops below the corresponding threshold voltage. The reset outputs remain asserted for $t_{RST(\text{min})}$ after V_{IN} and/or V_{DD} subsequent return above the threshold boundaries and/or /MR is released. A reset pulse is also generated at power-on.

Manual Reset

The ability to initiate a reset via external logic or a manual switch is provided in addition to the MIC2777's automatic supervisory functions. Typically, a momentary push-button switch is connected such that IN is shorted to ground when the switch contacts close. Assuming V_{DD} and V_{IN} are within tolerance when the switch is released, the reset outputs will be de-asserted no less than 140ms later. IN can also be driven by an open-drain or open-collector logic signal.

Application Information

Programming the Voltage Threshold

Referring to the “Typical Application Circuit”, the voltage threshold on the IN pin is calculated as follows:

$$V_{TH} = V_{REF} \times \frac{(R1+R2)}{R2}$$

$$\text{where } V_{REF} = 0.300V$$

In order to provide the additional criteria needed to solve for the resistor values, the resistors can be selected such that the two resistors have a given total value, that is, $R1 + R2 = R_{TOTAL}$. Imposing this condition on the resistor values provides two equations that can be solved for the two unknown resistor values. A value such as $1M\Omega$ for R_{TOTAL} is a reasonable choice since it keeps quiescent current to a generally acceptable level while not causing any measurable errors due to input bias currents. The larger the resistors, the larger the potential errors due to input bias current (I_{IN}). The maximum recommended value of R_{TOTAL} is $3M\Omega$.

Applying this criteria and rearranging the V_{TH} expression to solve for the resistor values gives:

$$R2 = \frac{(R_{TOTAL})(V_{REF})}{V_{TH}}$$

$$R1 = R_{TOTAL} - R2$$

Application Example

Figure 1 below illustrates a hypothetical MIC2777-23 application in which the MIC2777-23 is used to monitor the core and I/O supplies of a high-performance CPU or DSP. The core supply, V_{CORE} ; in this example is $1.0V \pm 5\%$. The main power rail and I/O voltage, $V_{I/O}$; is $2.5V \pm 5\%$. As shown in Figure 1, the MIC2777 is powered by $V_{I/O}$. The minimum value of $V_{I/O}$ is $2.5V - 5\% = 2.375V$; the maximum is $2.5V + 5\% = 2.625V$. This is well within the MIC2777's power supply range of 1.5V to 5.5V.

Resistors R1 and R2 must be selected to correspond to the V_{CORE} supply of 1.0V. The goal is to insure that the core supply voltage is adequate to insure proper operation, i.e., $V_{CORE} \geq (1.0V - 5\%) = 0.950V$. Because there is always a small degree of uncertainty due to the accuracy of the resistors, variations in the devices' voltage reference, etc., the threshold will be set slightly below this value. The potential variation in the MIC2777's input voltage reference (V_{REF}) is specified as $\pm 1.5\%$. The resistors chosen will have their own tolerance specification. This example will assume the use of 1% accurate resistors. The potential worst-case error contribution due to input bias current can be calculated once the resistor values are chosen. If the guidelines above regarding the maximum total value of $R1+R2$ are followed, this error contribution will be very small thanks to the MIC2777's very low input bias current.

To summarize, the various potential error sources are:

- Variation in V_{REF} : specified at $\pm 1.5\%$
- Resistor tolerance:
chosen by designer (typically $\leq \pm 1\%$)
- Input bias current, I_{IN} :
calculated once resistor values are known, typically very small

Taking the various potential error sources into account, the threshold voltage will be set slightly below the minimum V_{CORE} specification of 0.950V so that when the actual threshold voltage is at its maximum, it will not intrude into the normal operating range of V_{CORE} . The target threshold voltage will be set as follows:

Given that the total tolerance on V_{TH} for the IN pin is [V_{REF} tolerance] + [resistor tolerance]

$$= \pm 1.5\% + \pm 1\% = \pm 2.5\%,$$

$$\text{and } V_{TH(max)} = V_{CORE(min)},$$

$$\text{then } V_{CORE(min)} = V_{TH} + 2.5\% V_{TH} = 1.025 V_{TH},$$

therefore, solving for V_{TH} results in

$$V_{TH} = \frac{V_{CORE(min)}}{1.025} = \frac{0.950}{1.025} = 0.9268V$$

Solving for R1 and R2 using this value for V_{TH} and the equations above yields:

$$R1 = 676.3k\Omega \approx 673k\Omega$$

$$R2 = 323.7k\Omega \approx 324k\Omega$$

The resulting circuit is shown in Figure 1.

Input Bias Current Effects

Now that the resistor values are known, it is possible to calculate the maximum potential error due to input bias current, I_{IN} . As shown in the “Electrical Characteristics” table, the maximum value of I_{IN} is 10nA. (Note that the typical value is a much smaller 5pA!) The magnitude of the offset caused by I_{IN} is given by:

$$V_{ERROR} = I_{IN(max)} \times (R1 \parallel R2) =$$

$$V_{ERROR} = \pm 1 \times 10^{-8} A \times 2.189 \times 10^5 \Omega =$$

$$V_{ERROR} = \pm 2.189 \times 10^{-3} V =$$

$$V_{ERROR} = \pm 2.189mV$$

The typical error is about three orders of magnitude lower than this - close to one *microvolt!* Generally, the error due to input bias can be discounted. If it is to be taken into account, simply adjust the target threshold voltage downward by this amount and recalculate R1 and R2. The resulting value will be very close to optimum. If accuracy is more important than the quiescent current in the resistors, simply reduce the value of R_{TOTAL} to minimize offset errors.

Application Information

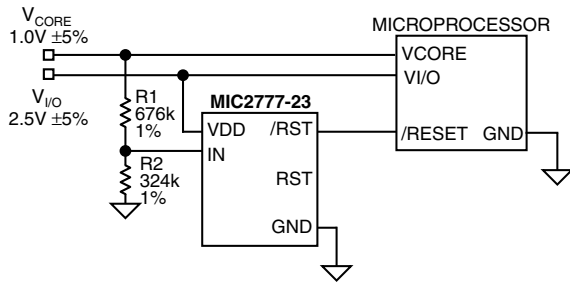

Figure 1. MIC2777 Example Design

Transient response

The MIC2777 is inherently immune to very short negative-going “glitches.” Very brief transients may exceed the voltage thresholds without tripping the output.

As shown in Figure 3a and 3b, in general the narrower the transient, the deeper the threshold overdrive that will be ignored by the MIC2777. The graph represents the typical allowable transient duration for a given amount of threshold overdrive that will not generate a reset.

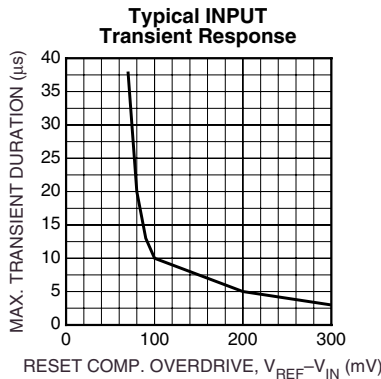

Figure 3a. Typical INPUT Transient Response

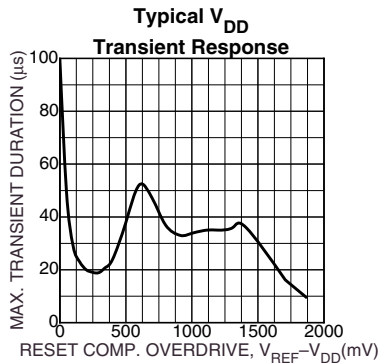

Figure 3b. Typical V_{DD} Transient Response

Ensuring Proper Operation at Low Supply

At levels of V_{DD} below 1.2V, the MIC2777's /RST output cannot turn on sufficiently to produce a valid logic-low on /RST. In this situation, other circuits driven by /RST could be allowed to float, causing undesired operation. (In most cases,

however, it is expected that the circuits driven by the MIC2777 will be similarly inoperative at V_{DD} ≤ 1.2V.)

If a given application requires that /RST be valid below V_{DD} = 1.2V, this can be accomplished by adding a pull-down resistor to the /RST output. A value of 100kΩ is recommended as this is usually an acceptable compromise of quiescent current and pull-down current. The resistor's value is not critical, however. See Figure 4.

The statements above also apply to the MIC2777's RST output. That is, to ensure valid RST signal levels at V_{DD} < 1.2V, a pull-up resistor (as opposed to a pull-down) should be added to the RST output. A value of 100kΩ is typical for this application as well. See Figure 5.

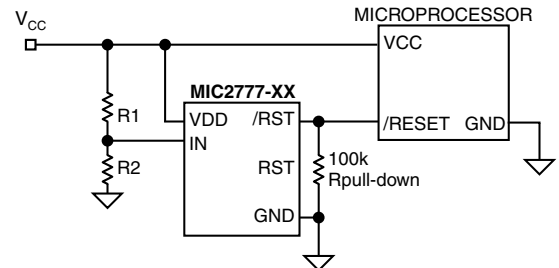

Figure 4. MIC2777 Valid /RST Below 1.2V

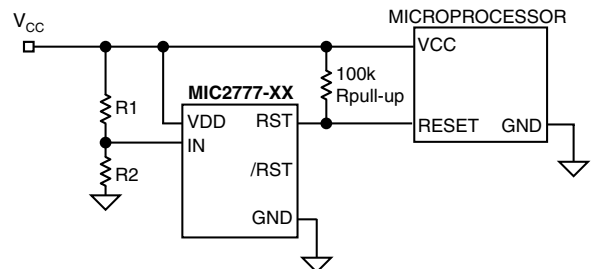
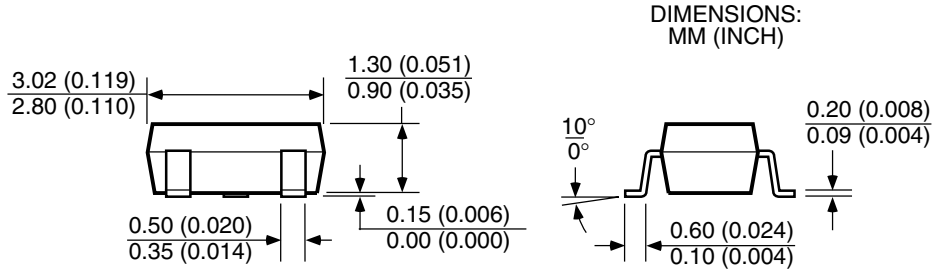
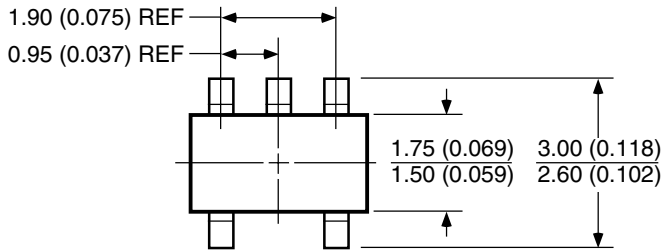

Figure 5. MIC2777 Valid RST Below 1.2V

Package Information



DIMENSIONS:
MM (INCH)

SOT-23-5 (M5)

MICREL INC. 1849 FORTUNE DRIVE SAN JOSE, CA 95131 USA

TEL + 1 (408) 944-0800 FAX + 1 (408) 944-0970 WEB <http://www.micrel.com>

This information is believed to be accurate and reliable, however no responsibility is assumed by Micrel for its use nor for any infringement of patents or other rights of third parties resulting from its use. No license is granted by implication or otherwise under any patent or patent right of Micrel Inc.

© 2000 Micrel Incorporated