

## MM54C150/MM74C150 16-Line to 1-Line Multiplexer MM72C19/MM82C19 TRI-STATE® 16-Line to 1-Line Multiplexer

### General Description

The MM54C150/MM74C150 and MM72C19/MM82C19 multiplex 16 digital lines to 1 output. A 4-bit address code determines the particular 1-of-16 inputs which is routed to the output. The data is inverted from input to output.

A strobe override places the output of MM54C150/MM74C150 in the logical "1" state and the output of MM72C19/MM82C19 in the high-impedance state.

All inputs are protected from damage due to static discharge by diode clamps to  $V_{CC}$  and GND.

### Features

- Wide supply voltage range 3.0V to 15V
- Guaranteed noise margin 1.0V
- High noise immunity 0.45  $V_{CC}$  (typ.)
- TTL compatibility Drive 1 TTL Load

### Connection Diagram

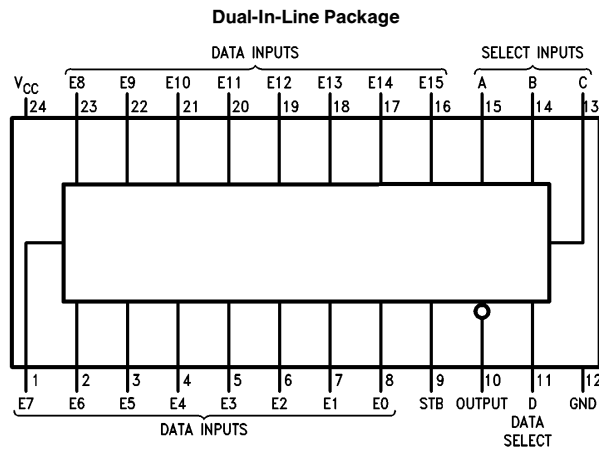

TL/F/5891-1

MM54C150/MM74C150 16-Line to 1-Line Multiplexer  
MM72C19/MM82C19 TRI-STATE 16-Line to 1-Line Multiplexer

## Absolute Maximum Ratings (Note 1)

If Military/Aerospace specified devices are required, please contact the National Semiconductor Sales Office/Distributors for availability and specifications.

Voltage at Any Pin	-0.3V to $V_{CC} + 0.3V$
Operating Temperature Range	-55°C to +125°C
MM54C150, MM72C19	-40°C to +85°C
MM74C150, MM82C19	

Storage Temperature Range	-65°C to +150°C
Power Dissipation	
Dual-In-Line	700 mW
Small Outline	500 mW
Operating $V_{CC}$ Range	3.0V to 15V
$V_{CC}$	18V
Lead Temperature (soldering, 10 seconds)	260°C

## DC Electrical Characteristics

Min/Max limits apply across temperature range unless otherwise noted.

Symbol	Parameter	Conditions	Min	Typ	Max	Units
<b>CMOS to CMOS</b>						
$V_{IN(1)}$	Logical "1" Input Voltage	$V_{CC} = 5.0V$ $V_{CC} = 10V$	3.5 8.0			V V
$V_{IN(0)}$	Logical "0" Input Voltage	$V_{CC} = 5.0V$ $V_{CC} = 10V$			1.5 2.0	V V
$V_{OUT(1)}$	Logical "1" Output Voltage	$V_{CC} = 5.0V, I_O = -10 \mu A$ $V_{CC} = 10V, I_O = -10 \mu A$	4.5 9.0			V V
$V_{OUT(0)}$	Logical "0" Output Voltage	$V_{CC} = 5.0V, I_O = +10 \mu A$ $V_{CC} = 10V, I_O = +10 \mu A$			0.5 1.0	V V
$I_{IN(1)}$	Logical "1" Input Current	$V_{CC} = 15V, V_{IN} = 15V$		0.005	1.0	V
$I_{IN(0)}$	Logical "0" Input Current	$V_{CC} = 15V, V_{IN} = 0V$	-1.0	-0.005		$\mu A$
$I_{OZ}$	Output Current in High Impedance State MM72C19/MM82C19	$V_{CC} = 15V, V_O = 15V$ $V_{CC} = 15V, V_O = 0V$	-1.0	0.005 -0.005	1.0	$\mu A$ $\mu A$
$I_{CC}$	Supply Current	$V_{CC} = 15V$		0.05	300	$\mu A$
<b>CMOS/LPTTL Interface</b>						
$V_{IN(1)}$	Logical "1" Input Voltage	54C, 72C, $V_{CC} = 4.5V$ 74C, 82C, $V_{CC} = 4.75V$	$V_{CC} - 1.5$ $V_{CC} - 1.5$			V V
$V_{IN(0)}$	Logical "0" Input Voltage	54C, 72C, $V_{CC} = 4.5V$ 74C, 82C, $V_{CC} = 4.75V$			0.8 0.8	V V
$V_{OUT(1)}$	Logical "1" Output Voltage	54C, 72C, $V_{CC} = 4.5V, I_O = -1.6 mA$ 74C, 82C, $V_{CC} = 4.75V, I_O = -1.6 mA$	2.4 2.4			V V
$V_{OUT(0)}$	Logical "0" Output Voltage	54C, 72C, $V_{CC} = 4.5V, I_O = 1.6 mA$ 74C, 82C, $V_{CC} = 4.75V, I_O = 1.6 mA$			0.4 0.4	V V
<b>Output Drive (Short Circuit Current)</b>						
$I_{SOURCE}$	Output Source Current (P-Channel)	$V_{CC} = 5.0V, V_{OUT} = 0V, T_A = 25^\circ C$	-4.35	-8		mA
$I_{SOURCE}$	Output Source Current (P-Channel)	$V_{CC} = 10V, V_{OUT} = 0V, T_A = 25^\circ C$	-20	-40		mA
$I_{SINK}$	Output Sink Current (N-Channel)	$V_{CC} = 5.0V, V_{OUT} = V_{CC}, T_A = 25^\circ C$	4.35	8		mA
$I_{SINK}$	Output Sink Current (N-Channel)	$V_{CC} = 10V, V_{OUT} = V_{CC}, T_A = 25^\circ C$	20	40		mA

**Note 1:** "Absolute Maximum Ratings" are those values beyond which the safety of the device cannot be guaranteed. Except for "Operating Temperature Range" they are not meant to imply that the devices should be operated at these limits. The table of "Electrical Characteristics" provides conditions for actual device operation.

### AC Electrical Characteristics\* $T_A = 25^\circ\text{C}$ , $C_L = 50\text{ pF}$ , unless otherwise noted

Symbol	Parameter	Conditions	Min	Typ	Max	Units
$t_{pd0}$ , $t_{pd1}$	Propagation Delay Time to a Logical "0" or Logical "1" from Data Inputs to Output	$V_{CC} = 5.0\text{V}$ $V_{CC} = 10\text{V}$ $V_{CC} = 5.0\text{V}$ , $C_L = 150\text{ pF}$ $V_{CC} = 10\text{V}$ , $C_L = 150\text{ pF}$		250 110 290 120	600 300 650 330	ns ns ns ns
$t_{pd0}$ , $t_{pd1}$	Propagation Delay Time to a Logical "0" or Logical "1" from Data Select Inputs to Output	$V_{CC} = 5.0\text{V}$ $V_{CC} = 10\text{V}$		290 120	650 330	ns ns
$t_{pd0}$ , $t_{pd1}$	Propagation Delay Time to a Logical "0" or Logical "1" from Strobe to Output MM54C150/MM74C150	$V_{CC} = 5.0\text{V}$ $V_{CC} = 10\text{V}$		120 55	300 150	ns ns
$t_{1H}$ , $t_{0H}$	Delay from Strobe to High Impedance State MM72C19/MM82C19	$V_{CC} = 5.0\text{V}$ , $R_L = 10\text{k}$ , $C_L = 5\text{ pF}$ $V_{CC} = 10\text{V}$ , $R_L = 10\text{k}$ , $C_L = 5\text{ pF}$		80 60	200 150	ns ns
$t_{H1}$ , $t_{H0}$	Delay from Strobe to Logical "1" Level or to Logical "0" Level (from High Impedance State) MM72C19/MM82C19	$V_{CC} = 5.0\text{V}$ , $R_L = 10\text{k}$ , $C_L = 5\text{ pF}$ $V_{CC} = 10\text{V}$ , $R_L = 10\text{k}$ , $C_L = 5\text{ pF}$		80 30	250 120	ns ns
$C_{IN}$	Input Capacitance	Any Input (Note 2)		5.0		pF
$C_{OUT}$	Output Capacitance MM72C19/MM82C19	(Note 2)		11.0		pF
$C_{PD}$	Power Dissipation Capacitance	(Note 3)		100		pF

\*AC Parameters are guaranteed by DC correlated testing.

**Note 1:** "Absolute Maximum Ratings" are those values beyond which the safety of the device cannot be guaranteed. Except for "Operating Temperature Range" they are not meant to imply that the devices should be operated at these limits. The table of "Electrical Characteristics" provides conditions for actual device operation.

**Note 2:** Capacitance is guaranteed by periodic testing.

**Note 3:**  $C_{PD}$  determines the no load AC power consumption of any CMOS device. For complete explanation, see 54C/74C Family Characteristics, application note AN-90.

# Truth Table

## MM54C150/MM74C150

Inputs																				Output	
D	C	B	A	STROBE	E0	E1	E2	E3	E4	E5	E6	E7	E8	E9	E10	E11	E12	E13	E14	E15	W
X	X	X	X	1	X	X	X	X	X	X	X	X	X	X	X	X	X	X	X	X	1*
0	0	0	0	0	0	X	X	X	X	X	X	X	X	X	X	X	X	X	X	X	1
0	0	0	0	0	0	1	X	X	X	X	X	X	X	X	X	X	X	X	X	X	0
0	0	0	1	0	0	X	0	X	X	X	X	X	X	X	X	X	X	X	X	X	1
0	0	0	1	0	0	X	1	X	X	X	X	X	X	X	X	X	X	X	X	X	0
0	0	1	0	0	0	X	X	0	X	X	X	X	X	X	X	X	X	X	X	X	1
0	0	1	0	0	0	X	X	1	X	X	X	X	X	X	X	X	X	X	X	X	0
0	0	1	1	0	0	X	X	X	0	X	X	X	X	X	X	X	X	X	X	X	1
0	0	1	1	0	0	X	X	X	1	X	X	X	X	X	X	X	X	X	X	X	0
0	1	0	0	0	0	X	X	X	0	X	X	X	X	X	X	X	X	X	X	X	1
0	1	0	0	0	0	X	X	X	X	1	X	X	X	X	X	X	X	X	X	X	0
0	1	0	1	0	0	X	X	X	X	0	X	X	X	X	X	X	X	X	X	X	1
0	1	0	1	0	0	X	X	X	X	1	X	X	X	X	X	X	X	X	X	X	0
0	1	1	0	0	0	X	X	X	X	X	0	X	X	X	X	X	X	X	X	X	1
0	1	1	0	0	0	X	X	X	X	X	1	X	X	X	X	X	X	X	X	X	0
0	1	1	1	0	0	X	X	X	X	X	X	0	X	X	X	X	X	X	X	X	1
0	1	1	1	0	0	X	X	X	X	X	1	X	X	X	X	X	X	X	X	X	0
1	0	0	0	0	0	X	X	X	X	X	X	0	X	X	X	X	X	X	X	X	1
1	0	0	0	0	0	X	X	X	X	X	X	1	X	X	X	X	X	X	X	X	0
1	0	0	1	0	0	X	X	X	X	X	X	0	X	X	X	X	X	X	X	X	1
1	0	0	1	0	0	X	X	X	X	X	X	1	X	X	X	X	X	X	X	X	0
1	0	1	0	0	0	X	X	X	X	X	X	X	0	X	X	X	X	X	X	X	1
1	0	1	0	0	0	X	X	X	X	X	X	1	X	X	X	X	X	X	X	X	0
1	0	1	1	0	0	X	X	X	X	X	X	X	0	X	X	X	X	X	X	X	1
1	0	1	1	0	0	X	X	X	X	X	X	1	X	X	X	X	X	X	X	X	0
1	0	1	1	0	0	X	X	X	X	X	X	X	0	X	X	X	X	X	X	X	1
1	0	1	1	0	0	X	X	X	X	X	X	1	X	X	X	X	X	X	X	X	0
1	1	0	0	0	0	X	X	X	X	X	X	X	0	X	X	X	X	X	X	X	1
1	1	0	0	0	0	X	X	X	X	X	X	X	1	X	X	X	X	X	X	X	0
1	1	0	1	0	0	X	X	X	X	X	X	X	0	X	X	X	X	X	X	X	1
1	1	0	1	0	0	X	X	X	X	X	X	X	1	X	X	X	X	X	X	X	0
1	1	1	0	0	0	X	X	X	X	X	X	X	0	X	X	X	X	X	X	X	1
1	1	1	0	0	0	X	X	X	X	X	X	X	1	X	X	X	X	X	X	X	0
1	1	1	1	0	0	X	X	X	X	X	X	X	0	X	X	X	X	X	X	X	1
1	1	1	1	0	0	X	X	X	X	X	X	X	1	X	X	X	X	X	X	X	0
1	1	1	1	1	0	X	X	X	X	X	X	X	0	X	X	X	X	X	X	X	1
1	1	1	1	1	0	X	X	X	X	X	X	X	1	X	X	X	X	X	X	X	0
1	1	1	1	1	0	X	X	X	X	X	X	X	0	X	X	X	X	X	X	X	1
1	1	1	1	1	0	X	X	X	X	X	X	X	1	X	X	X	X	X	X	X	0

\*For MM72C19/MM82C19 this would be Hi-Z, everything else is the same.

## Switching Time Waveforms

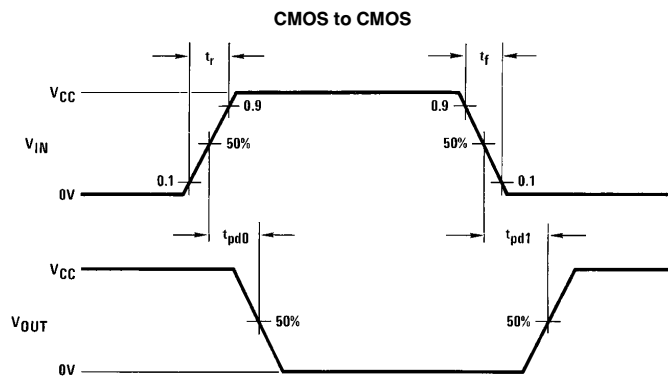

TL/F/5891-2

## Switching Time Waveforms (Continued)

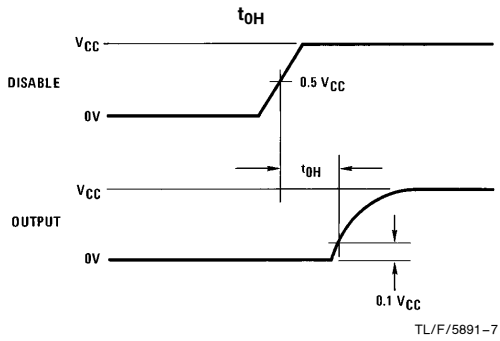
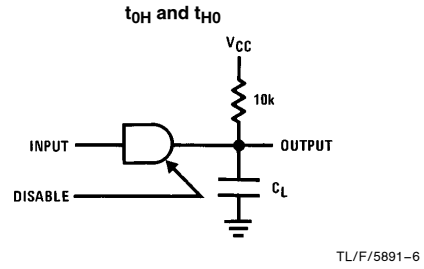
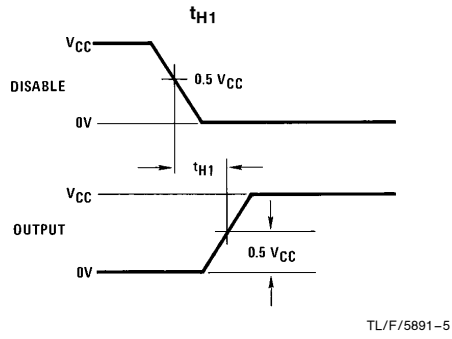
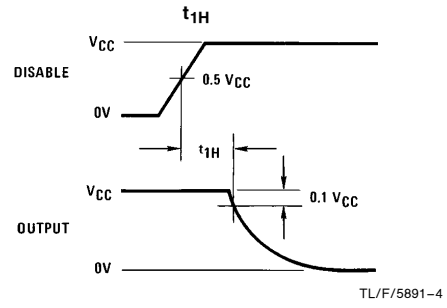
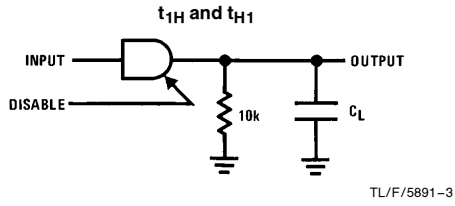

**Note:** Delays measured with input  $t_r, t_f \leq 20$  ns.

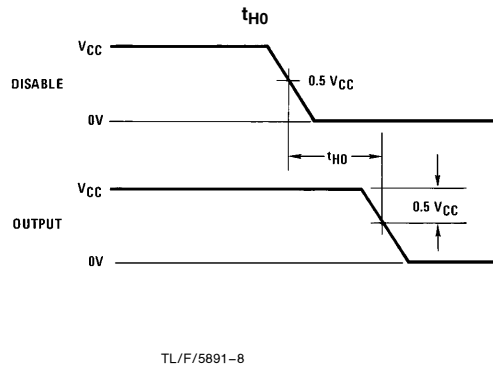

Logic Diagrams

MM54C150/MM74C150

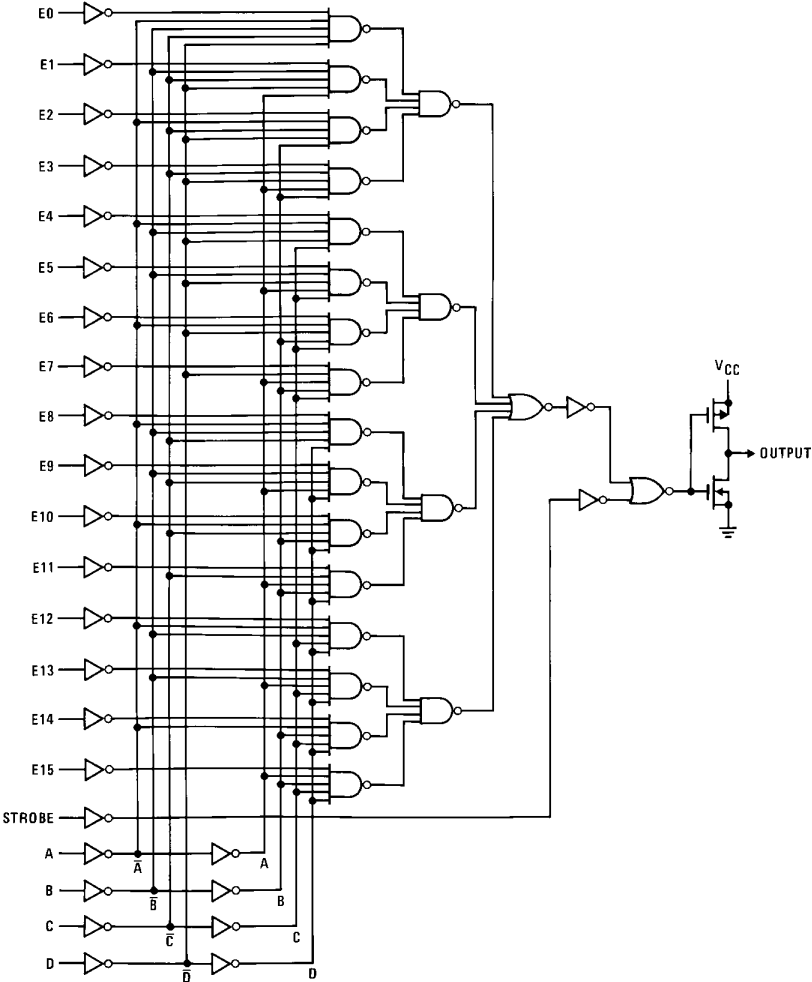

TL/F/5891-9

Logic Diagrams (Continued)

MM72C19/MM82C19

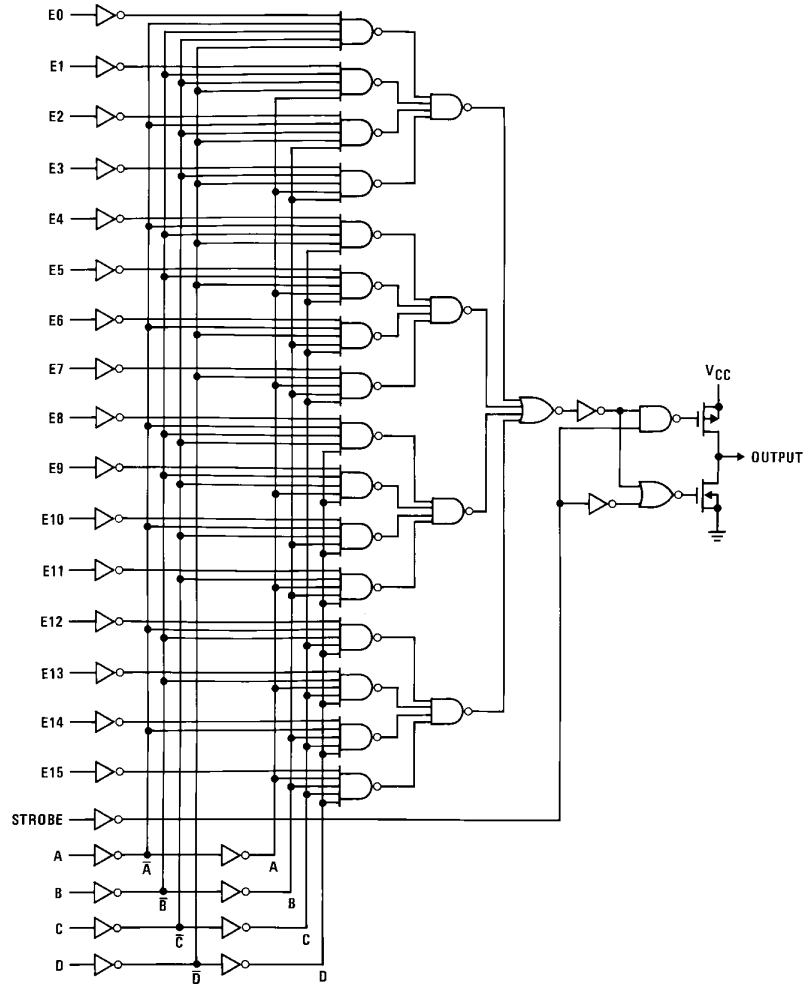

TL/F/5891-10

**MM54C150/MM74C150 16-Line to 1-Line Multiplexer**  
**MM72C19/MM82C19 TRI-STATE 16-Line to 1-Line Multiplexer**

**Physical Dimensions** inches (millimeters)

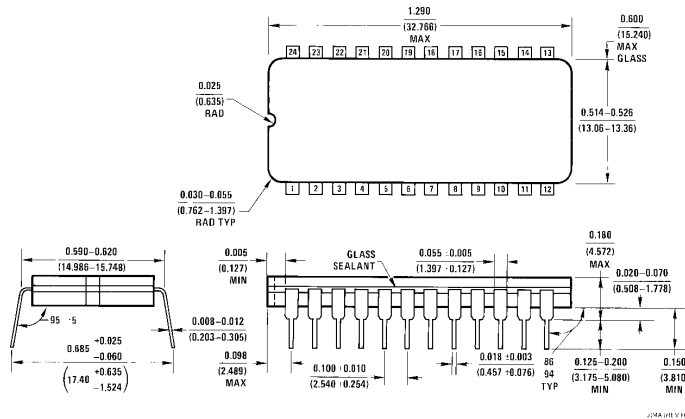

**Ceramic Dual-In-Line Package (J)**  
**Order Number MM54C150J or MM74C150J, MM72C19J or MM82C19J**  
**NS Package Number J24A**

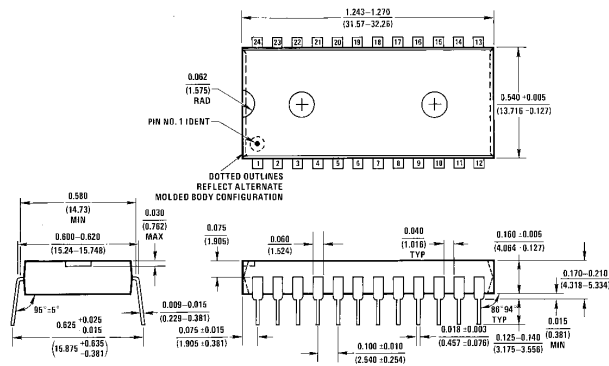

**Molded Dual-In-Line Package (N)**  
**Order Number MM54C150N, MM74C150N, MM72C19N or MM82C19N**  
**NS Package Number N24A**

**LIFE SUPPORT POLICY**

NATIONAL'S PRODUCTS ARE NOT AUTHORIZED FOR USE AS CRITICAL COMPONENTS IN LIFE SUPPORT DEVICES OR SYSTEMS WITHOUT THE EXPRESS WRITTEN APPROVAL OF THE PRESIDENT OF NATIONAL SEMICONDUCTOR CORPORATION. As used herein:

1. Life support devices or systems are devices or systems which, (a) are intended for surgical implant into the body, or (b) support or sustain life, and whose failure to perform, when properly used in accordance with instructions for use provided in the labeling, can be reasonably expected to result in a significant injury to the user.
2. A critical component is any component of a life support device or system whose failure to perform can be reasonably expected to cause the failure of the life support device or system, or to affect its safety or effectiveness.

 <p><b>National Semiconductor Corporation</b>          1111 West Bardin Road          Arlington, TX 76017          Tel: 1(800) 272-9959          Fax: 1(800) 737-7018</p>	<p><b>National Semiconductor Europe</b>          Fax: (+49) 0-180-530 85 86          Email: cnjwge@tevm2.nsc.com          Deutsch Tel: (+49) 0-180-530 85 85          English Tel: (+49) 0-180-532 78 32          Français Tel: (+49) 0-180-532 93 58          Italiano Tel: (+49) 0-180-534 16 80</p>	<p><b>National Semiconductor Hong Kong Ltd.</b>          19th Floor, Straight Block,          Ocean Centre, 5 Canton Rd.          Tsimshatsui, Kowloon          Hong Kong          Tel: (852) 2737-1600          Fax: (852) 2736-9960</p>	<p><b>National Semiconductor Japan Ltd.</b>          Tel: 81-043-299-2309          Fax: 81-043-299-2408</p>
--	--	---	---

National does not assume any responsibility for use of any circuitry described, no circuit patent licenses are implied and National reserves the right at any time without notice to change said circuitry and specifications.