

Connecting SP5301 to MPC850 PowerQUICC™

Processors in the Motorola MPC850 PowerQUICC™ family support one USB host port at a 12Mbit/sec data rate. They require an external USB transceiver, such as the [SP5301](#), to provide the analog interface to the Universal Serial Bus.

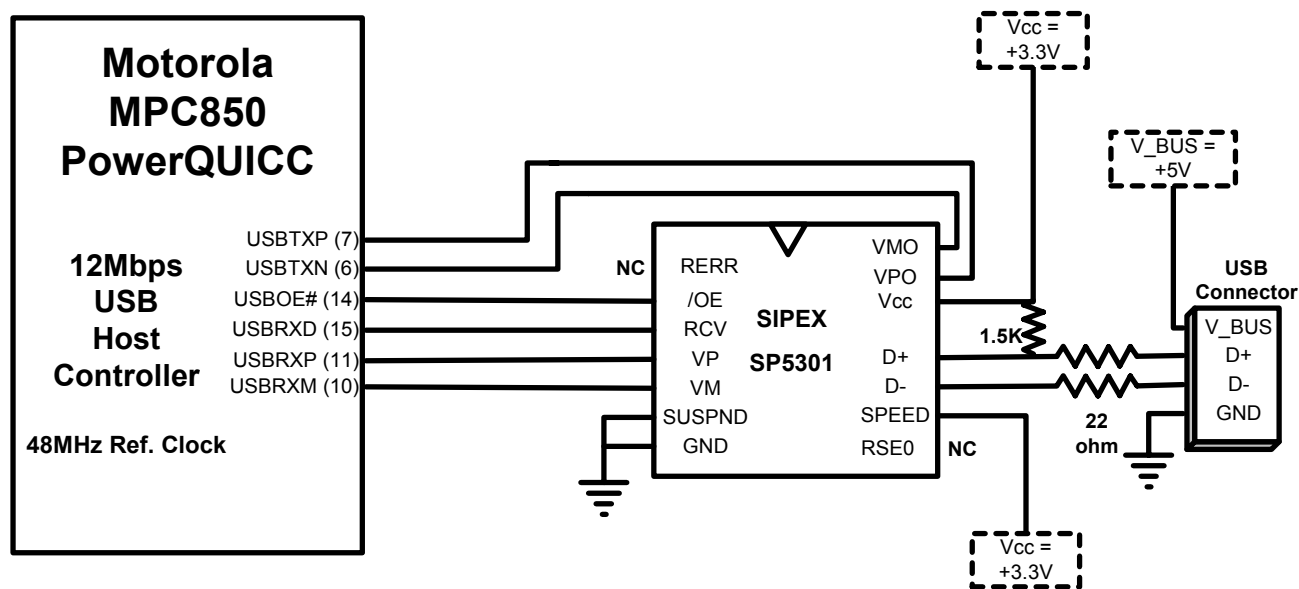

Not shown:
 0.1uF Bypass capacitor on Vcc
 Float RERR and RSE0 (No Connect)

The USB controller on the MPC850 uses six signals. Additional signals such as SUSPEND and SPEED can be driven using general purpose outputs if desired.

Signal MPC	Dir	Signal SP5301	Function
USBTXN	→	VMO	Data outputs from Host, Inputs to Transceiver,
USBTXP	→	VPO	Driven onto D- and D+
USBOE#	→	OE#	Output Enable, controls SP5301 transmit or receive
USBRXD	←	RCV	Differential Receive
USBRXP	←	VP	Single Ended Receive. Gated version of D+ and D-. Used to detect Single-ended Zero (EOF and Reset)
USBRXM	←	VM	
Optional Signals	→	SUSP	Drive high to put SP5301 into low power state
	→	SPEED	Drive low to adjust driver slew rate for Low Speed (1.5Mbps)
	←	RERR	Outputs high if D+ and D- are 11 (illegal state). Leave unconnected if not used
	←	RSE0	Outputs high if D+ and D- are 00 (SE0). Leave unconnected if not used