



PZT5401

PNP EPITAXIAL SILICON TRANSISTOR

HIGH VOLTAGE SWITCHING TRANSISTOR

■ FEATURES

*High Collector-Emitter Voltage:

$V_{CE0} = -150V$

*High current gain

APPLICATIONS

*Telephone Switching Circuit

*Amplifier

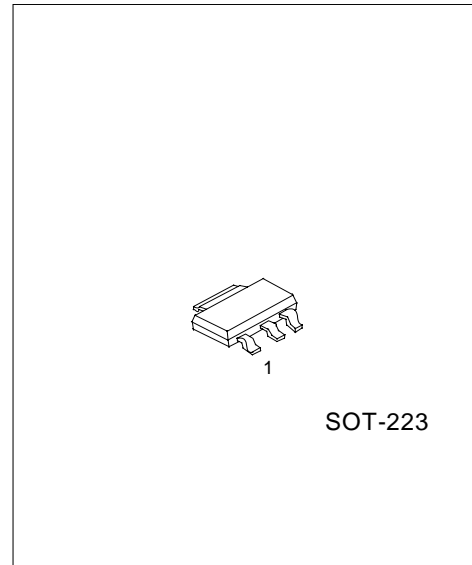

*Pb-free plating product number:PZT5401L

■ PIN CONFIGURATION

PIN NO.	PIN NAME
1	Base
2	Collector
3	Emitter

■ ORDERING INFORMATION

Order Number		Package	Packing
Normal	Lead Free Plating		
PZT5401-AA3-R	PZT5401L-AA3-R	SOT-223	Tape & Reel

■ ABSOLUTE MAXIMUM RATINGS ($T_a = 25$, unless otherwise specified)

PARAMETER	SYMBOL	RATINGS	UNIT
Collector-Base Voltage	V_{CB0}	-160	V
Collector-Emitter Voltage	V_{CEO}	-150	V
Emitter-Base Voltage	V_{EBO}	-5	V
DC Collector Current	I_C	-600	mA
Power Dissipation	P_D	2	W
Operating Junction Temperature	T_J	+150	
Storage Temperature	T_{STG}	-40 ~ +150	

■ ELECTRICAL CHARACTERISTICS ($T_a = 25$, unless otherwise specified)

PARAMETER	SYMBOL	TEST CONDITIONS	MIN	TYP	MAX	UNIT
Collector-Base Breakdown Voltage	V_{CB0}	$I_C = 100\mu A, I_E = 0$	-160			V
Collector-Emitter Breakdown Voltage	V_{CEO}	$I_C = 1mA, I_B = 0$	-150			V
Emitter-Base Breakdown Voltage	V_{EBO}	$I_E = 10\mu A, I_C = 0$	-6			V
Collector Cut-off Current	I_{CBO}	$V_{CB} = 120V, I_E = 0$			-50	nA
Emitter Cut-off Current	I_{EBO}	$V_{BE} = -3V, I_C = 0$			-50	nA
DC Current Gain(note)	h_{FE}	$V_{CE} = -5V, I_C = -1mA$	80		400	
		$V_{CE} = -5V, I_C = -10mA$	80			
		$V_{CE} = -5V, I_C = -50mA$	80			
Collector-Emitter Saturation Voltage	$V_{CE(sat)}$	$I_C = -10mA, I_B = -1mA$ $I_C = -50mA, I_B = -5mA$			-0.2 -0.5	V
Base-Emitter Saturation Voltage	$V_{BE(sat)}$	$I_C = -10mA, I_B = -1mA$ $I_C = -50mA, I_B = -5mA$			-1 -1	V
Current Gain Bandwidth Product	f_T	$V_{CE} = -10V, I_C = -10mA, f = 100MHz$	100		400	MHz
Output Capacitance	C_{ob}	$V_{CB} = -10V, I_E = 0, f = 1MHz$			6.0	pF
Noise Figure	N_F	$I_C = -0.25mA, V_{CE} = -5V$ $R_S = 1k\Omega, f = 10Hz \sim 15.7kHz$			8	dB

Note: Pulse test: $PW < 300\mu s$, Duty Cycle $< 2\%$

■ CLASSIFICATION OF h_{FE}

RANK	A	B	C
RANGE	80-170	150-240	200-400

■ TYPICAL CHARACTERISTICS

Fig.1 Collector output Capacitance

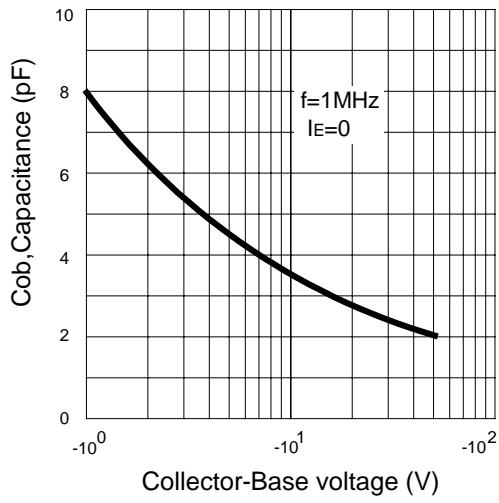

Fig.2 DC current Gain

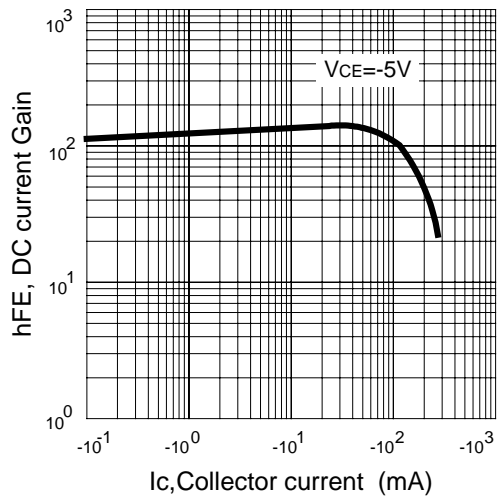

Fig.3 Base-Emitter on Voltage

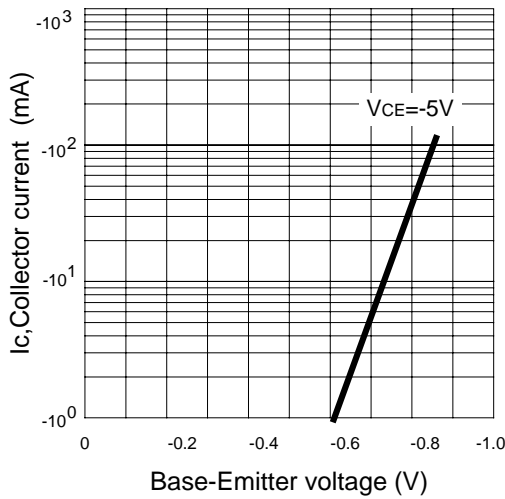

Fig.4 Saturation voltage

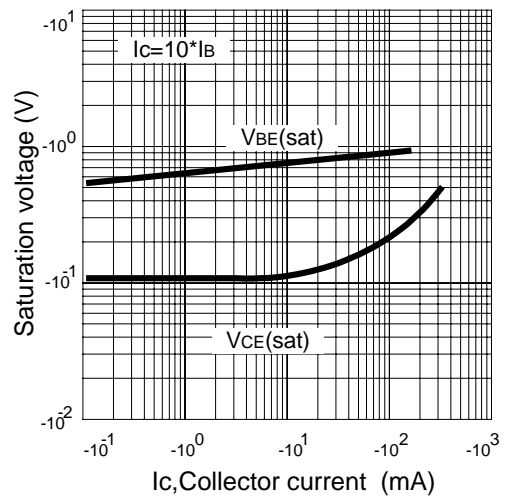
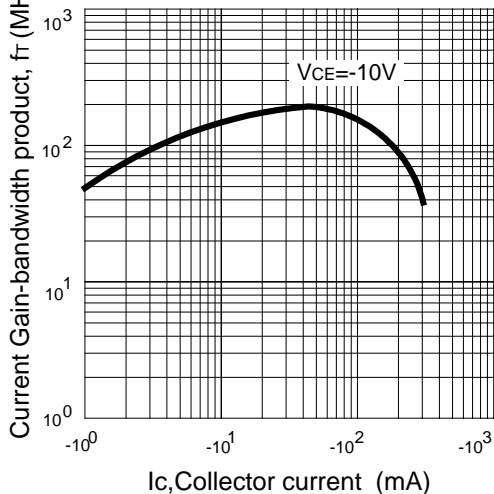

Fig.5 Current gain-bandwidth product



UTC assumes no responsibility for equipment failures that result from using products at values that exceed, even momentarily, rated values (such as maximum ratings, operating condition ranges, or other parameters) listed in products specifications of any and all UTC products described or contained herein. UTC products are not designed for use in life support appliances, devices or systems where malfunction of these products can be reasonably expected to result in personal injury. Reproduction in whole or in part is prohibited without the prior written consent of the copyright owner. The information presented in this document does not form part of any quotation or contract, is believed to be accurate and reliable and may be changed without notice.