

Smart Two Channel Highside Power Switch For Industrial Applications

Features

- Overload protection
- Current limitation
- Short circuit protection
- Thermal shutdown
- Overvoltage protection (including load dump)
- Fast demagnetization of inductive loads
- Reverse battery protection¹⁾
- Undervoltage and overvoltage shutdown with auto-restart and hysteresis
- Open drain diagnostic output
- Open load detection in OFF-state
- CMOS compatible input
- Loss of ground and loss of V_{bb} protection
- Electrostatic discharge (ESD) protection

Application

- μ C compatible power switch with diagnostic feedback for 12 V and 24 V DC grounded loads in industrial applications
- All types of resistive, inductive and capacitive loads
- Replaces electromechanical relays, fuses and discrete circuits

Product Summary

Overvoltage protection	$V_{bb(AZ)}$	43	V	
Operating voltage	$V_{bb(on)}$	5.0 ... 34	V	
Operating temperature	T_a	-30 ... +85	°C	
		channels:		
		each	both parallel	
On-state resistance	R_{ON}	200	100	m Ω
Load current (ISO)	$I_{L(ISO)}$	2.3	4.4	A
Current limitation	$I_{L(Scr)}$	4	4	A

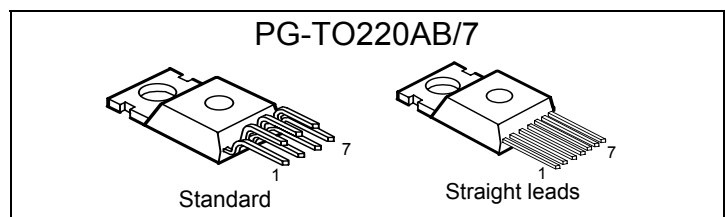

General Description

N channel vertical power FET with charge pump, ground referenced CMOS compatible input and diagnostic feedback, monolithically integrated in Smart SIPMOS® technology. Providing embedded protective functions.

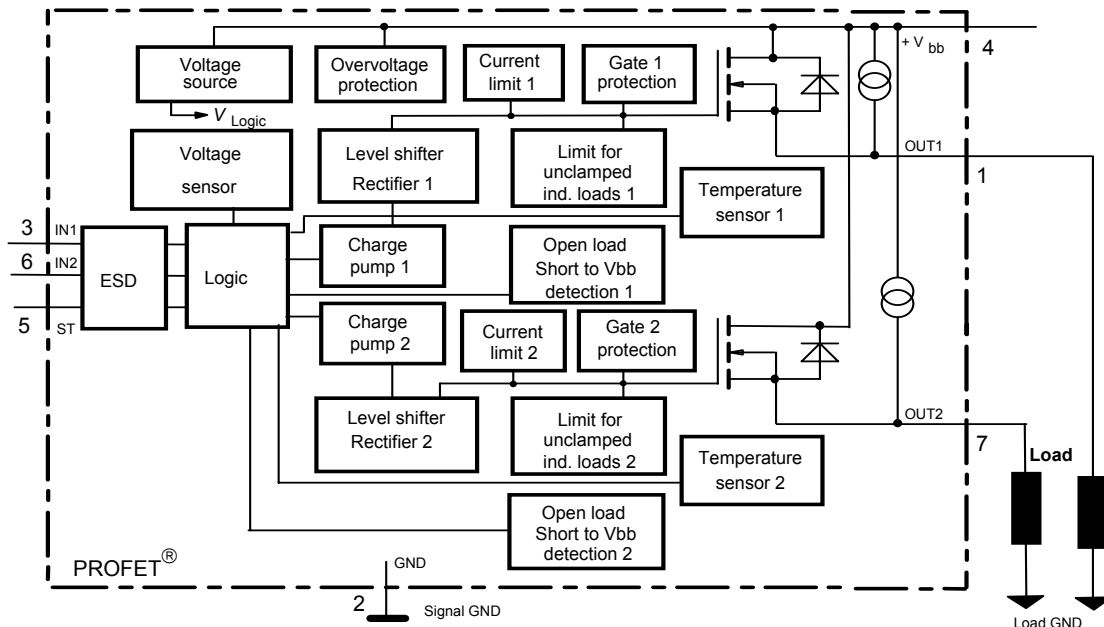

¹⁾ With external current limit (e.g. resistor $R_{GND}=150 \Omega$) in GND connection, resistor in series with ST connection, reverse load current limited by connected load.

Pin	Symbol	Function
1	OUT1 (Load, L)	Output 1, protected high-side power output of channel 1
2	GND	Logic ground
3	IN1	Input 1, activates channel 1 in case of logical high signal
4	V _{bb}	Positive power supply voltage, the tab is shorted to this pin
5	ST	Diagnostic feedback: open drain, low on failure
6	IN2	Input 2, activates channel 2 in case of logical high signal
7	OUT2 (Load, L)	Output 2, protected high-side power output of channel 2

Maximum Ratings at $T_j = 25\text{ °C}$ unless otherwise specified

Parameter	Symbol	Values	Unit
Supply voltage (overvoltage protection see page 4)	V_{bb}	43	V
Supply voltage for full short circuit protection $T_{j\text{ start}} = -40 \dots +150\text{ °C}$	V_{bb}	34	V
Load dump protection ²⁾ $V_{\text{LoadDump}} = U_A + V_s$, $U_A = 13.5\text{ V}$ $R_1^3 = 2\ \Omega$, $R_L = 5.3\ \Omega$, $t_d = 200\text{ ms}$, IN= low or high	$V_{\text{Load dump}}^4)$	60	V
Load current (Short circuit current, see page 5)	I_L	self-limited	A
Junction temperature	T_j	+150	°C
Operating temperature range	T_a	-30 ... +85	
Storage temperature range	T_{stg}	-40 ... +105	
Power dissipation (DC), $T_C \leq 25\text{ °C}$	P_{tot}	36	W
Inductive load switch-off energy dissipation, single pulse $V_{bb} = 12\text{ V}$, $T_{j,\text{start}} = 150\text{ °C}$, $T_C = 150\text{ °C}$ const. one channel, $I_L = 2.3\text{ A}$, $Z_L = 89\text{ mH}$, $0\ \Omega$: both channels parallel, $I_L = 4.4\text{ A}$, $Z_L = 47\text{ mH}$, $0\ \Omega$: see diagrams on page 9	E_{AS}	290 580	mJ
Electrostatic discharge capability (ESD) (Human Body Model) acc. MIL-STD883D, method 3015.7 and ESD assn. std. S5.1-1993	IN: V_{ESD} all other pins:	1.0 2.0	kV
Input voltage (DC)	V_{IN}	-10 ... +16	V
Current through input pin (DC)	I_{IN}	± 2.0	mA
Current through status pin (DC) see internal circuit diagrams page 7	I_{ST}	± 5.0	

²⁾ Supply voltages higher than $V_{bb(AZ)}$ require an external current limit for the GND and status pins, e.g. with a $150\ \Omega$ resistor in the GND connection and a $15\text{ k}\Omega$ resistor in series with the status pin. A resistor for the protection of the input is integrated.

³⁾ R_1 = internal resistance of the load dump test pulse generator

⁴⁾ $V_{\text{Load dump}}$ is setup without the DUT connected to the generator per ISO 7637-1 and DIN 40839

Parameter and Conditions, each channel at $T_j = 25\text{ °C}$, $V_{bb} = 12\text{ V}$ unless otherwise specified	Symbol	Values			Unit
		min	typ	max	



Thermal Characteristics

Parameter and Conditions	Symbol	Values			Unit
		min	typ	max	
Thermal resistance chip - case, both channels: each channel:	R_{thJC}	--	--	3.5	K/W
		--	--	7.0	
junction - ambient (free air):	R_{thJA}	--	--	75	

Electrical Characteristics

Parameter and Conditions, each channel at $T_j = 25\text{ °C}$, $V_{bb} = 12\text{ V}$ unless otherwise specified	Symbol	Values			Unit
		min	typ	max	

Load Switching Capabilities and Characteristics

On-state resistance (pin 4 to 1 or 7) $I_L = 1.8\text{ A}$ each channel	$T_j = 25\text{ °C}$: $T_j = 150\text{ °C}$:	R_{ON}	--	160 320	200 400	mΩ
Nominal load current, ISO Norm (pin 4 to 1 or 7) $V_{ON} = 0.5\text{ V}$, $T_C = 85\text{ °C}$	each channel: both channels parallel:	$I_{L(ISO)}$	1.8 3.5	2.3 4.4	-- --	A
Output current (pin 1 or 7) while GND disconnected or GND pulled up, $V_{bb} = 30\text{ V}$, $V_{IN} = 0$, see diagram page 8		$I_{L(GNDhigh)}$	--	--	10	mA
Turn-on time Turn-off time $R_L = 12\text{ Ω}$, $T_j = -40...+150\text{ °C}$	IN  to 90% V_{OUT} : IN  to 10% V_{OUT} :	t_{on} t_{off}	80 80	200 200	400 400	μs
Slew rate on 10 to 30% V_{OUT} , $R_L = 12\text{ Ω}$, $T_j = -40...+150\text{ °C}$		dV/dt_{on}	0.1	--	1	V/μs
Slew rate off 70 to 40% V_{OUT} , $R_L = 12\text{ Ω}$, $T_j = -40...+150\text{ °C}$		$-dV/dt_{off}$	0.1	--	1	V/μs

Parameter and Conditions, each channel at $T_j = 25\text{ °C}$, $V_{bb} = 12\text{ V}$ unless otherwise specified	Symbol	Values			Unit
		min	typ	max	

Operating Parameters

Operating voltage ⁵⁾	$T_j = -40\dots+150\text{ °C}$:	$V_{bb(\text{on})}$	5.0	--	34	V
Undervoltage shutdown	$T_j = -40\dots+150\text{ °C}$:	$V_{bb(\text{under})}$	3.5	--	5.0	V
Undervoltage restart	$T_j = -40\dots+25\text{ °C}$: $T_j = +150\text{ °C}$:	$V_{bb(\text{u rst})}$	--	--	5.0 7.0	V
Undervoltage restart of charge pump see diagram page 12		$V_{bb(\text{ucp})}$	--	5.6	7.0	V
Undervoltage hysteresis $\Delta V_{bb(\text{under})} = V_{bb(\text{u rst})} - V_{bb(\text{under})}$		$\Delta V_{bb(\text{under})}$	--	0.2	--	V
Overvoltage shutdown	$T_j = -40\dots+150\text{ °C}$:	$V_{bb(\text{over})}$	34	--	43	V
Overvoltage restart	$T_j = -40\dots+150\text{ °C}$:	$V_{bb(\text{o rst})}$	33	--	--	V
Overvoltage hysteresis	$T_j = -40\dots+150\text{ °C}$:	$\Delta V_{bb(\text{over})}$	--	0.5	--	V
Overvoltage protection ⁶⁾ $I_{bb} = 40\text{ mA}$	$T_j = -40\dots+150\text{ °C}$:	$V_{bb(\text{AZ})}$	42	47	--	V
Standby current (pin 4), $V_{IN} = 0$	$T_j = -40\dots+150\text{ °C}$:	$I_{bb(\text{off})}$	--	90	150	μA
Operating current (Pin 2) ⁷⁾ , $V_{IN} = 5\text{ V}$ both channels on, $T_j = -40\dots+150\text{ °C}$,		I_{GND}	--	0.6	1.2	mA
Operating current (Pin 2) ⁷⁾ one channel on, $T_j = -40\dots+150\text{ °C}$;		I_{GND}	--	0.4	0.7	mA

⁵⁾ At supply voltage increase up to $V_{bb} = 5.6\text{ V}$ typ without charge pump, $V_{OUT} \approx V_{bb} - 2\text{ V}$

⁶⁾ See also $V_{ON(\text{CL})}$ in table of protection functions and circuit diagram page 8.

⁷⁾ Add I_{ST} , if $I_{ST} > 0$, add I_{IN} , if $V_{IN} > 5.5\text{ V}$

Parameter and Conditions, each channel at $T_j = 25\text{ °C}$, $V_{bb} = 12\text{ V}$ unless otherwise specified	Symbol	Values			Unit
		min	typ	max	
Protection Functions⁸⁾					
Initial peak short circuit current limit (pin 4 to 1 or 7) $T_j = -40\text{ °C}$: $T_j = 25\text{ °C}$: $T_j = +150\text{ °C}$:	$I_{L(SCp)}$	5.5 4.5 2.5	9.5 7.5 4.5	13 11 7	A
Repetitive short circuit shutdown current limit $T_j = T_{jt}$ (see timing diagrams, page 11)	$I_{L(SCr)}$	--	4	--	A
Output clamp (inductive load switch off) at $V_{OUT} = V_{bb} - V_{ON(CL)}$ $I_L = 40\text{ mA}$:	$V_{ON(CL)}$	41	47	53	V
Thermal overload trip temperature	T_{jt}	150	--	--	°C
Thermal hysteresis	ΔT_{jt}	--	10	--	K
Reverse battery (pin 4 to 2) ⁹⁾	$-V_{bb}$	--	--	32	V
Reverse battery voltage drop ($V_{out} > V_{bb}$) $I_L = -1.9\text{ A}$, each channel $T_j = 150\text{ °C}$:	$-V_{ON(rev)}$	--	610	--	mV
Diagnostic Characteristics					
Open load detection current (included in standby current $I_{bb(off)}$)	$I_{L(off)}$	--	30	--	μA
Open load detection voltage $T_j = -40..150\text{ °C}$:	$V_{OUT(OL)}$	2	3	4	V

⁸⁾ Integrated protection functions are designed to prevent IC destruction under fault conditions described in the data sheet. Fault conditions are considered as "outside" normal operating range. Protection functions are not designed for continuous repetitive operation.

⁹⁾ Requires 150 Ω resistor in GND connection. The reverse load current through the intrinsic drain-source diode has to be limited by the connected load. Note that the power dissipation is higher compared to normal operating conditions due to the voltage drop across the intrinsic drain-source diode. The temperature protection is not active during reverse current operation! Input and Status currents have to be limited (see max. ratings page 2 and circuit page 8).

Parameter and Conditions, each channel at $T_j = 25^\circ\text{C}$, $V_{bb} = 12\text{ V}$ unless otherwise specified	Symbol	Values			Unit
		min	typ	max	
Input and Status Feedback¹⁰⁾					
Input resistance $T_j = -40..150^\circ\text{C}$, see circuit page 7	R_i	2.5	3.5	6	$\text{k}\Omega$
Input turn-on threshold voltage \nearrow $T_j = -40..+150^\circ\text{C}$:	$V_{IN(T+)}$	1.7	--	3.5	V
Input turn-off threshold voltage \searrow $T_j = -40..+150^\circ\text{C}$:	$V_{IN(T-)}$	1.5	--	--	V
Input threshold hysteresis	$\Delta V_{IN(T)}$	--	0.5	--	V
Off state input current (pin 3 or 6), $V_{IN} = 0.4\text{ V}$, $T_j = -40..+150^\circ\text{C}$	$I_{IN(\text{off})}$	1	--	50	μA
On state input current (pin 3 or 6), $V_{IN} = 3.5\text{ V}$, $T_j = -40..+150^\circ\text{C}$	$I_{IN(\text{on})}$	20	50	90	μA
Delay time for status with open load after Input neg. slope (see diagram page 12)	$t_{d(\text{ST OL3})}$	--	220	--	μs
Status output (open drain)					
Zener limit voltage $T_j = -40...+150^\circ\text{C}$, $I_{ST} = +1.6\text{ mA}$:	$V_{ST(\text{high})}$	5.4	6.1	--	V
ST low voltage $T_j = -40...+25^\circ\text{C}$, $I_{ST} = +1.6\text{ mA}$:	$V_{ST(\text{low})}$	--	--	0.4	
$T_j = +150^\circ\text{C}$, $I_{ST} = +1.6\text{ mA}$:		--	--	0.6	

¹⁰⁾ If a ground resistor R_{GND} is used, add the voltage drop across this resistor.

Truth Table

		IN1	IN2	OUT1	OUT2	ST
						ITS612N1
Normal operation		L	L	L	L	H
		L	H	L	H	H
		H	L	H	L	H
		H	H	H	H	H
Open load	Channel 1	L	L	Z	L	L
		L	H	Z	H	H
		H	X	H	X	H
	Channel 2	L	L	L	Z	L
		H	L	H	Z	H
		X	H	X	H	H
Short circuit to V_{bb}	Channel 1	L	L	H	L	L
		L	H	H	H	H
		H	X	H	X	H
	Channel 2	L	L	L	H	L
		H	L	H	H	H
		X	H	X	H	H
Overtemperature	both channel	L	L	L	L	H
		X	H	L	L	L
		H	X	L	L	L
	Channel 1	L	X	L	X	H
		H	X	L	X	L
	Channel 2	X	L	X	L	H
X		H	X	L	L	
Undervoltage/ Overvoltage		X	X	L	L	H

L = "Low" Level X = don't care Z = high impedance, potential depends on external circuit
H = "High" Level Status signal after the time delay shown in the diagrams (see fig 5. page 12)

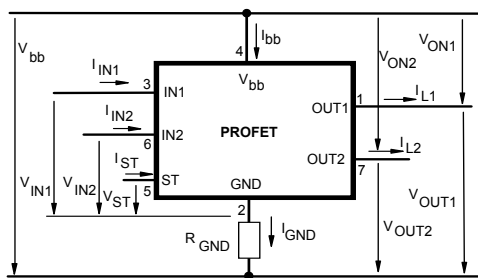
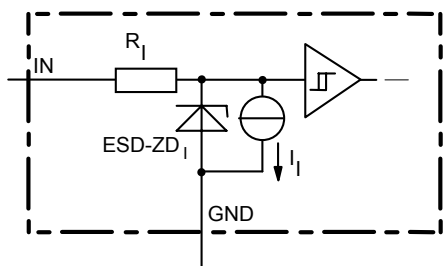
Terms

Input circuit (ESD protection)

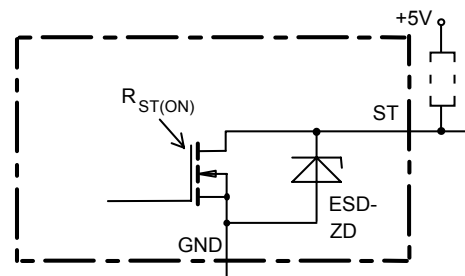
ESD zener diodes are not to be used as voltage clamp at DC conditions. Operation in this mode may result in a drift of the zener voltage (increase of up to 1 V).

Status output

ESD-Zener diode: 6.1 V typ., max 5 mA;
 $R_{ST(ON)} < 380 \Omega$ at 1.6 mA, ESD zener diodes are not to be used as voltage clamp at DC conditions.
Operation in this mode may result in a drift of the zener voltage (increase of up to 1 V).

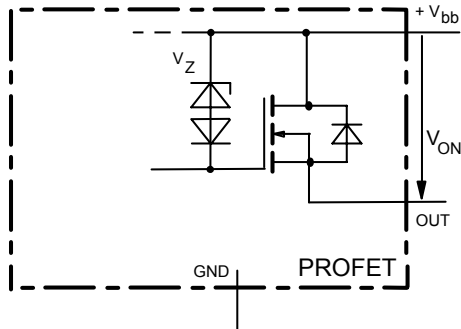
Inductive and overvoltage output clamp



V_{ON} clamped to 47 V typ.

Overvolt. and reverse batt. protection

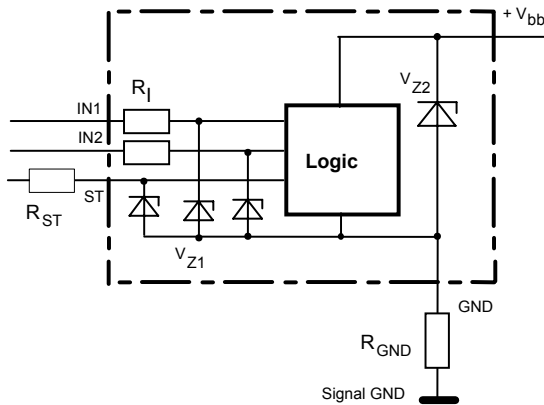

$V_{Z1} = 6.1$ V typ., $V_{Z2} = 47$ V typ., $R_1 = 3.5$ k Ω typ., $R_{GND} = 150$ Ω

Open-load detection

OFF-state diagnostic condition: $V_{OUT} > 3$ V typ.; IN low

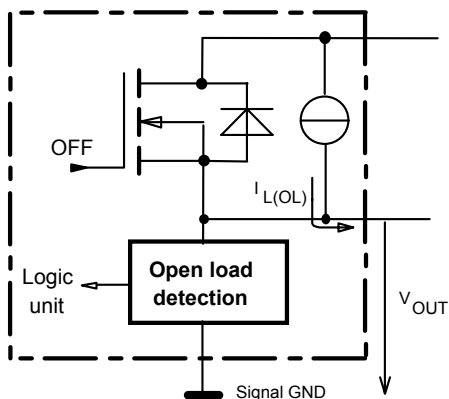

GND disconnect

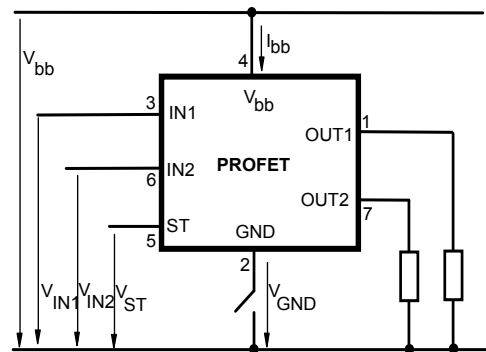

Any kind of load. In case of Input=high is $V_{OUT} \approx V_{IN} - V_{IN(T+)}$.
Due to $V_{GND} > 0$, no $V_{ST} =$ low signal available.

GND disconnect with GND pull up

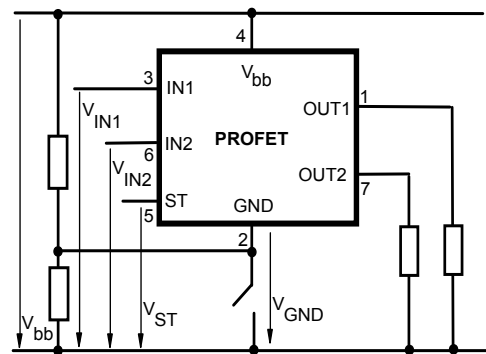

Any kind of load. If $V_{GND} > V_{IN} - V_{IN(T+)}$ device stays off
Due to $V_{GND} > 0$, no $V_{ST} =$ low signal available.

Vbb disconnect with energized inductive load

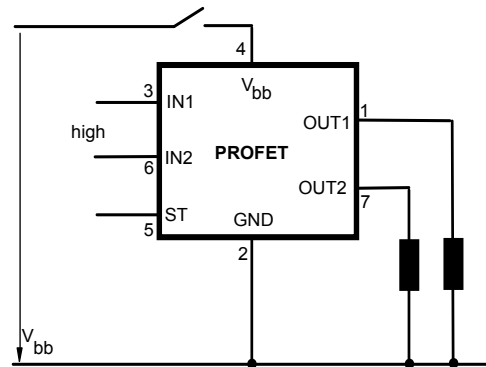

Normal load current can be handled by the PROFET itself.

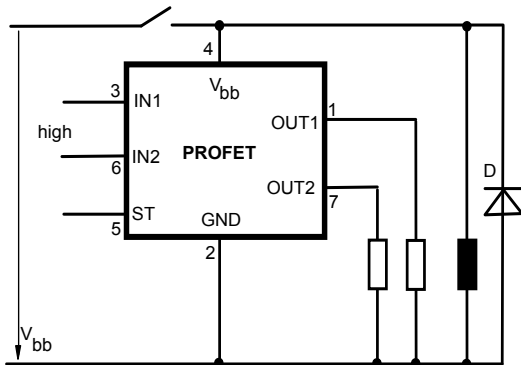
V_{bb} disconnect with charged external inductive load

If other external inductive loads L are connected to the PROFET, additional elements like D are necessary.

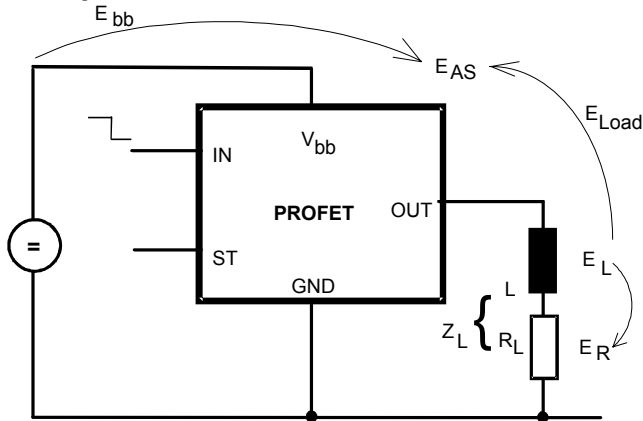
Inductive Load switch-off energy dissipation

Energy stored in load inductance:

$$E_L = \frac{1}{2} \cdot L \cdot I_L^2$$

While demagnetizing load inductance, the energy dissipated in PROFET is

$$E_{AS} = E_{bb} + E_L - E_R = \int V_{ON(CL)} \cdot i_L(t) dt,$$

with an approximate solution for $R_L > 0 \Omega$:

$$E_{AS} = \frac{I_L \cdot L}{2 \cdot R_L} \cdot (V_{bb} + |V_{OUT(CL)}|) \cdot \ln \left(1 + \frac{I_L \cdot R_L}{|V_{OUT(CL)}|} \right)$$

Maximum allowable load inductance for a single switch off (both channels parallel)

$L = f(I_L)$; $T_{j,start} = 150^\circ\text{C}$, $T_C = 150^\circ\text{C}$ const.,
 $V_{bb} = 12\text{V}$, $R_L = 0 \Omega$

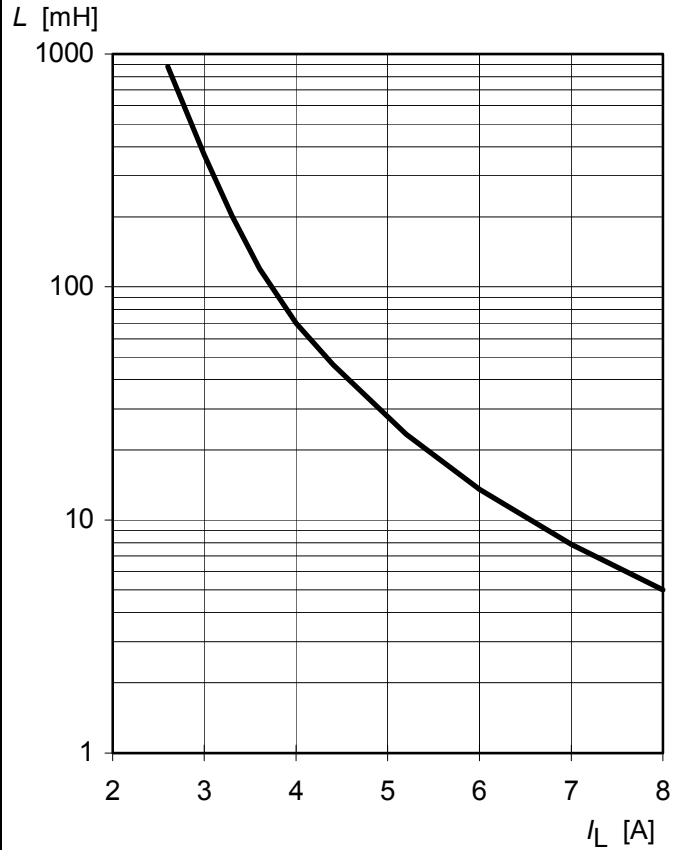

Typ. transient thermal impedance chip case

$Z_{thJC} = f(t_p)$, one Channel active

Z_{thJC} [K/W]

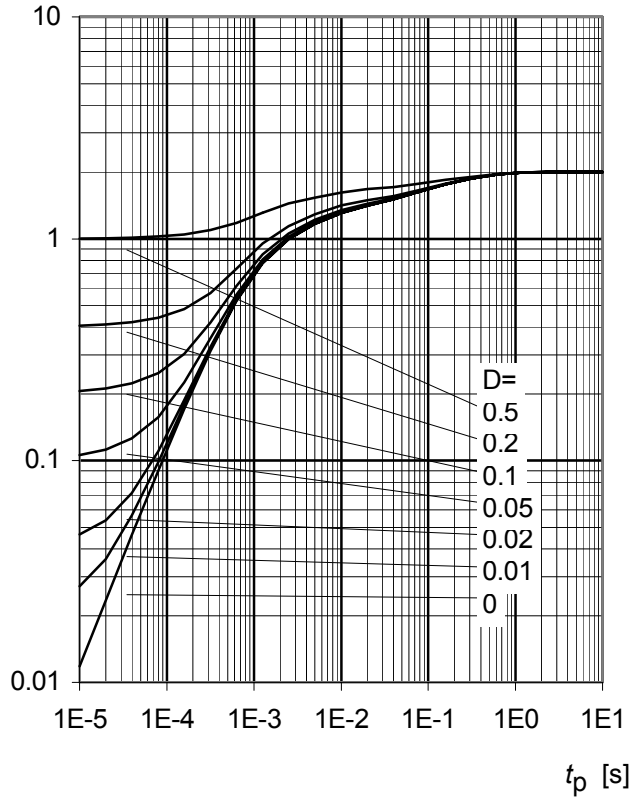

Transient thermal impedance chip case

$Z_{thJC} = f(t_p)$, both Channel active

Z_{thJC} [K/W]

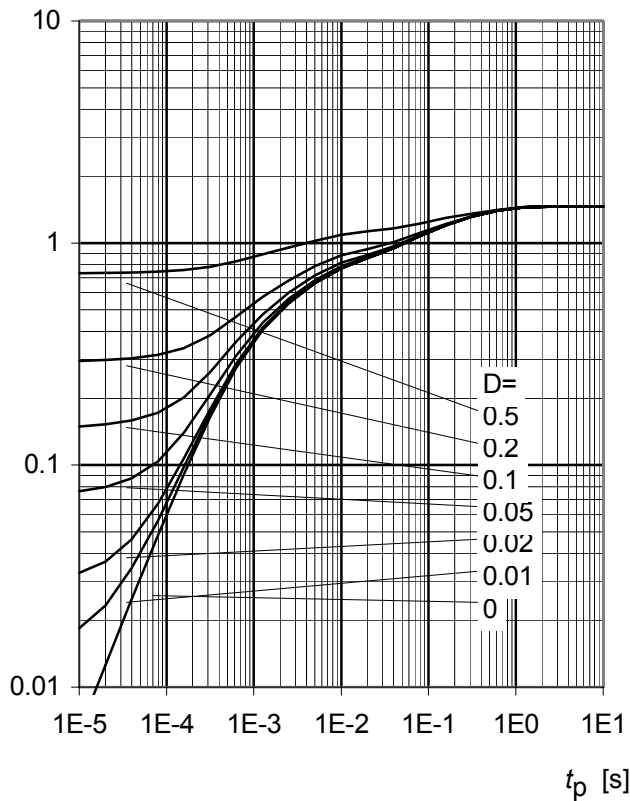

Timing diagrams

Both channels are symmetric and consequently the diagrams are valid for each channel as well as for permuted channels

Figure 1a: V_{bb} turn on:

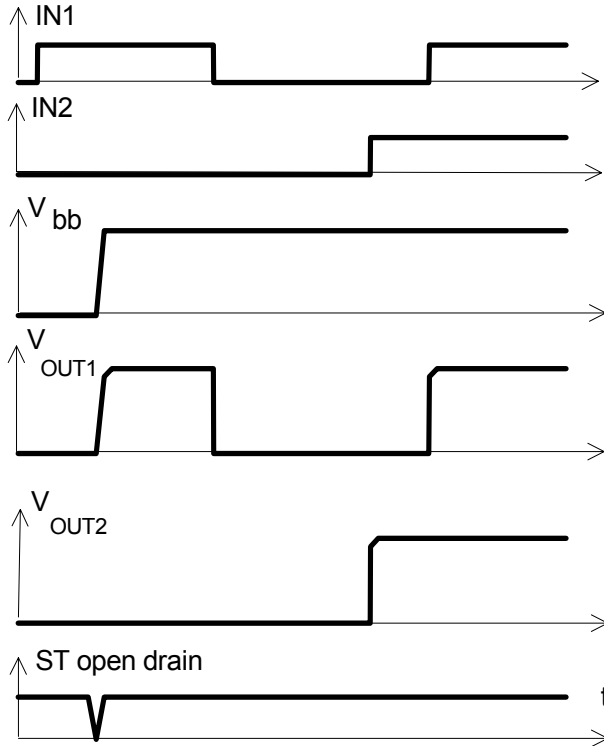

Figure 2a: Switching a lamp:

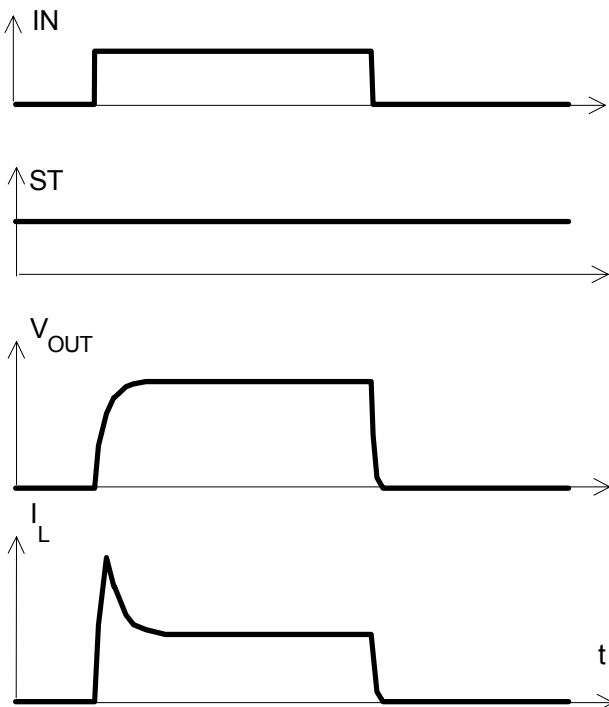

Figure 2b: Switching an inductive load

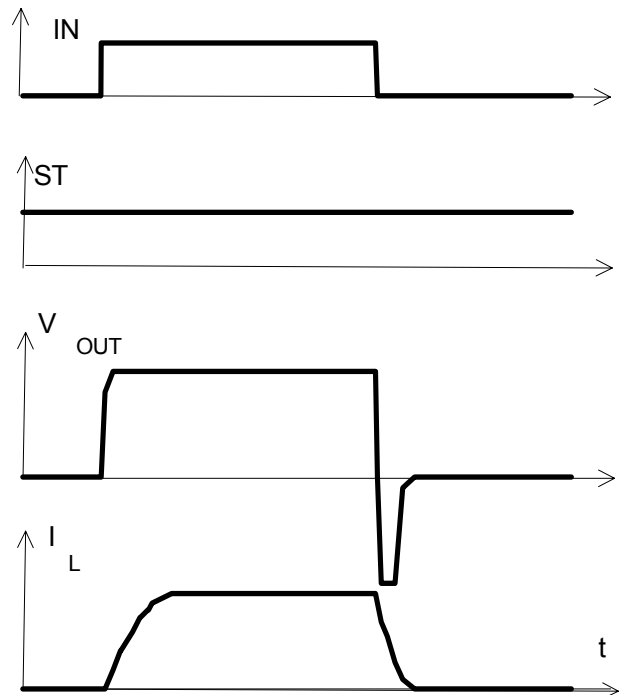

Figure 3a: Short circuit shut down by overtemperature, reset by cooling

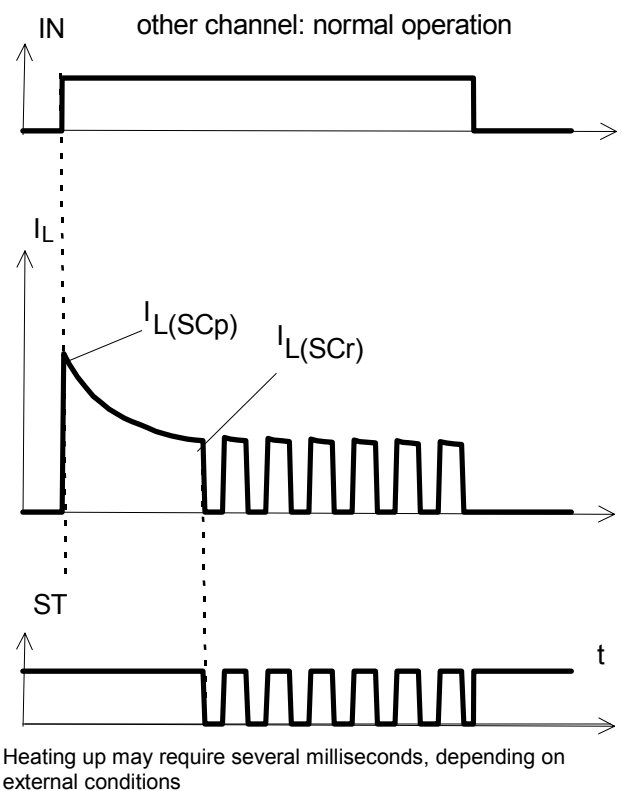

Figure 4a: Overtemperature:
Reset if $T_j < T_{jt}$

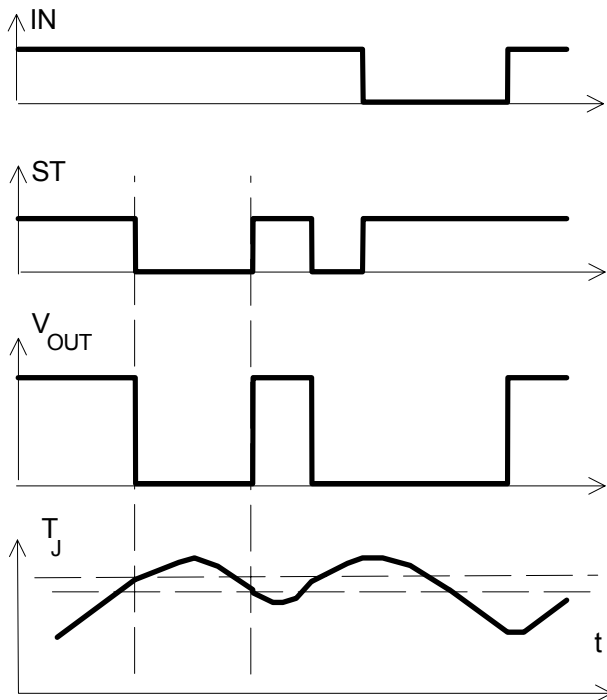
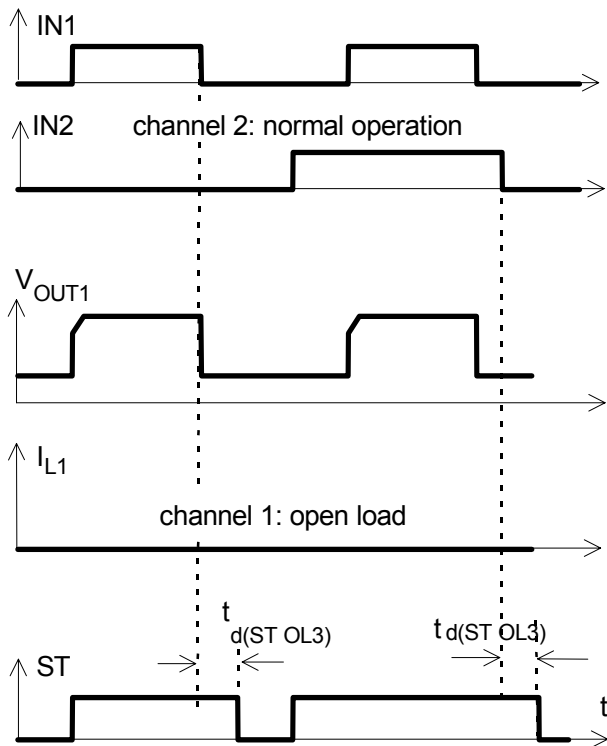

Figure 5a: Open load: detection in OFF-state, turn on/off to open load



$t_{d(ST,OL3)}$ depends on external circuitry because of high impedance
*) $I_L = 30 \mu A$ typ

Figure 6a: Undervoltage:

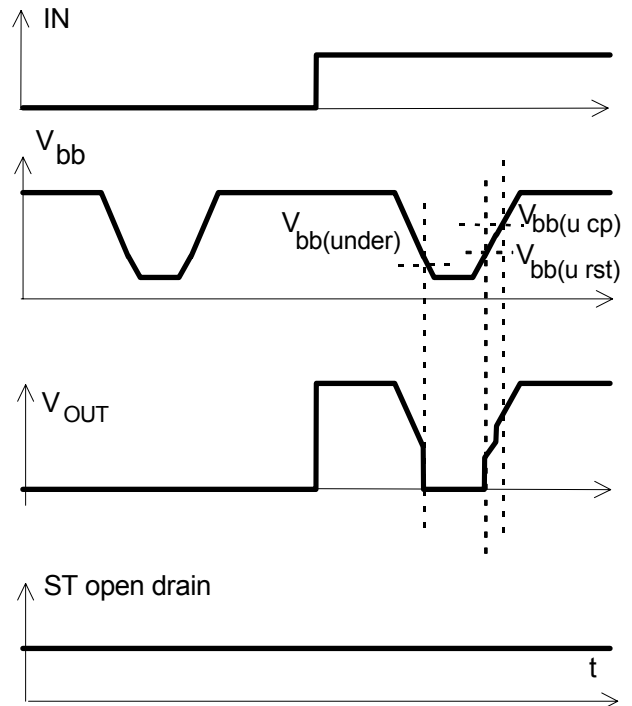
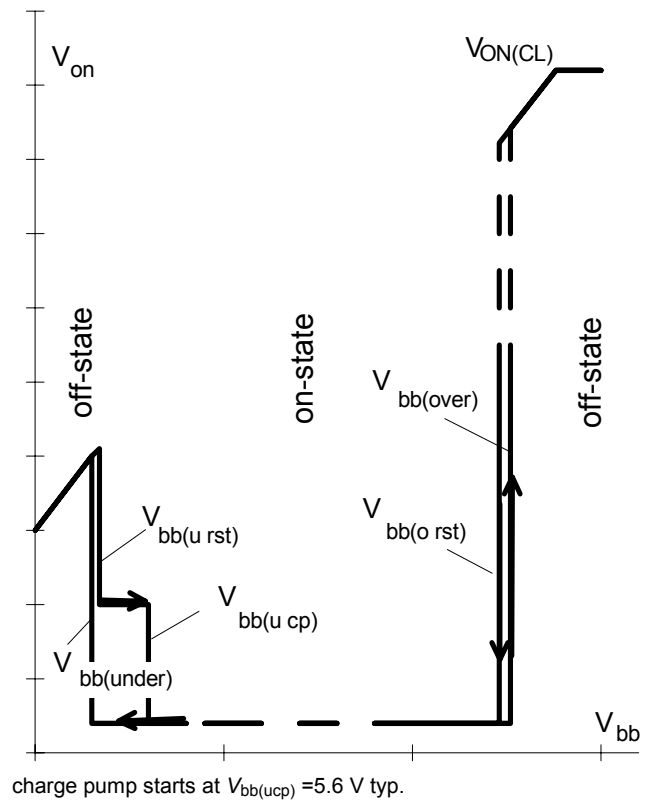
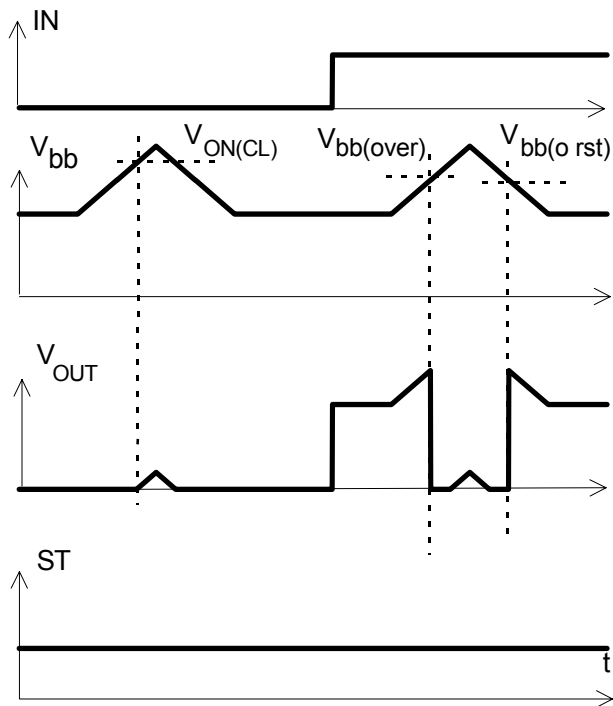

Figure 6b: Undervoltage restart of charge pump



charge pump starts at $V_{bb(ucp)} = 5.6 V$ typ.

Figure 7a: Overvoltage:



Package and Ordering Code

All dimensions in mm

Standard PG-TO220AB/7 Ordering code

ITS612N1	SP000221233
----------	-------------

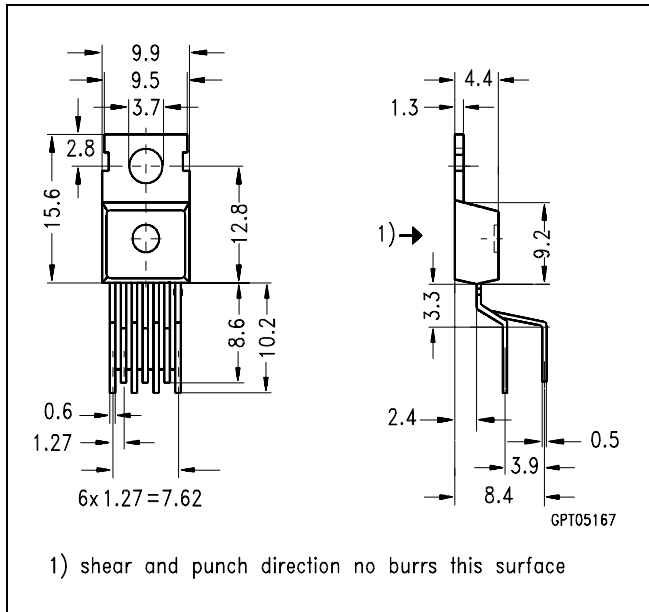

Published by
Infineon Technologies AG,
St.-Martin-Strasse 53,
D-81669 München
 © Infineon Technologies AG 2006
All Rights Reserved.

Attention please!

The information herein is given to describe certain components and shall not be considered as a guarantee of characteristics.

Terms of delivery and rights to technical change reserved.

We hereby disclaim any and all warranties, including but not limited to warranties of non-infringement, regarding circuits, descriptions and charts stated herein.

Infineon Technologies is an approved CECC manufacturer.

Information

For further information on technology, delivery terms and conditions and prices please contact your nearest Infineon Technologies Office in Germany or our Infineon Technologies Representatives worldwide (see address list).

Warnings

Due to technical requirements components may contain dangerous substances. For information on the types in question please contact your nearest Infineon Technologies Office.

Infineon Technologies Components may only be used in life-support devices or systems with the express written approval of Infineon Technologies, if a failure of such components can reasonably be expected to cause the failure of that life-support device or system, or to affect the safety or effectiveness of that device or system. Life support devices or systems are intended to be implanted in the human body, or to support and/or maintain and sustain and/or protect human life. If they fail, it is reasonable to assume that the health of the user or other persons may be endangered.

PG-TO220AB/7, Opt. E3230 Ordering code

ITS612N1 E3230	SP000221234
----------------	-------------

