

# 2955-2

T-52-17

## HIGH-CURRENT HALF-BRIDGE POWER DRIVER

The UDN2955W-2 half-bridge power driver combines a high-current, half-bridge power driver with low-level control and protection circuitry. For PWM applications there are provisions for output current sensing and an ENABLE (active low) input. The output can source or sink up to 6 A continuously. This device features a minimum break-down and sustaining voltage of 40 V. It can be used in pairs for full-bridge operation or in triplets for 3-phase brushless dc motors.

Protection is included which shuts down the device during over-temperature conditions caused by loss of cooling; internal flyback and clamp diodes are included for switching inductive loads. Internal logic lockout and delays prevent potentially destructive crossover currents. The logic inputs are compatible with TTL and 5 V CMOS logic systems.

A similar device, excluding the ENABLE and output current sensing provision, in a 5-lead TO-220 style package, is the UDN2951Z-2.

The UDN2955W-2 is supplied in a 12-lead power-tab single in-line plastic package. The tab is at ground potential, allowing multiple devices to share a common heat sink.

### FEATURES

- ± 6 A Continuous Output Current
- Output Voltage to 40 V
- Internal Thermal Shutdown
- TTL and 5 V CMOS Compatible Inputs
- Integral Transient-Suppression Diodes

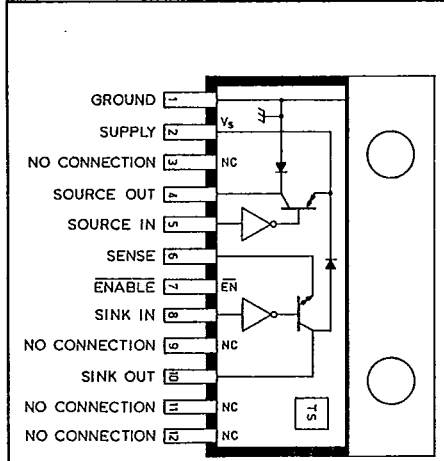

Dwg. PP-023

### ABSOLUTE MAXIMUM RATINGS at $T_j \leq 150^\circ\text{C}$

Supply Voltage, $V_S$ .....	40 V
Output Current, $I_{OUT}$ .....	±6.0 A
Input Voltage, $V_{IN}$ .....	7.0 V
Sense Voltage, $V_{SENSE}$ .....	1.5 V
Package Power Dissipation, $P_D$ .....	See Graph
Operating Temperature Range, $T_A$ .....	-20°C to + 85°C
Storage Temperature Range, $T_S$ .....	-55°C to + 150°C

Output current rating may be limited by duty cycle, ambient temperature, and heat sinking. Under any set of conditions, do not exceed the specified output current rating or a junction temperature of +150°C.

Always order by complete part number: **UDN2955W-2**.

**2955-2**  
**HIGH-CURRENT HALF-BRIDGE POWER DRIVER**

*J-52-17*

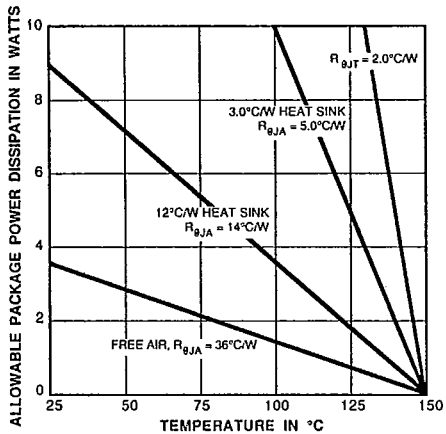

Dwg. GP-012A

**FUNCTIONAL BLOCK DIAGRAM**

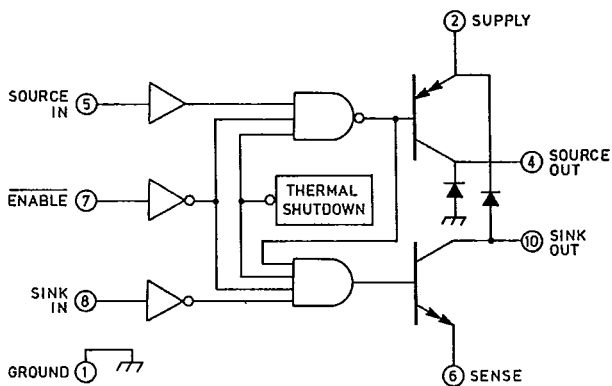

Dwg. FP-009

**TRUTH TABLE**

	INPUTS			OUTPUTS	
	ENABLE	SOURCE	SINK	SOURCE	SINK
Low	Low	Low	Low	OFF	ON
Low	Low	High	High	OFF	OFF
Low	High	X	X	ON	OFF
High	X	X	X	OFF	OFF

X = Irrelevant

**TYPICAL APPLICATION**

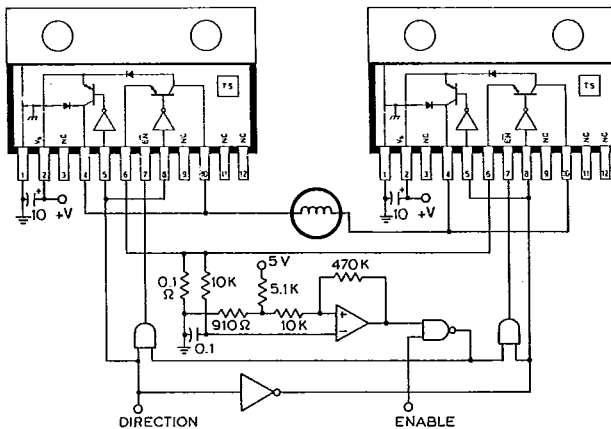

The printed wiring board should utilize a heavy ground plane. For optimum performance, the driver should be soldered directly into the board. The power supply ( $V_{CC}$ ) should be decoupled with an electrolytic capacitor ( $\geq 10 \mu\text{F}$ ) as close as possible to pin 2.

Dwg. EP-019A

2955-2

HIGH-CURRENT HALF-BRIDGE POWER DRIVER

T-52-17

ELECTRICAL CHARACTERISTICS at  $T_A = +25^\circ\text{C}$ ,  $T_J \leq +150^\circ\text{C}$ ,  $V_S = 40\text{ V}$

Characteristic	Symbol	Test Conditions	Limits			Units
			Min.	Typ.	Max.	
Functional Supply Range	$V_S$		10	—	40	V
Output Leakage Current	$I_{CEX}$	SINK <sub>OUT</sub> = 40 V, SOURCE <sub>IN</sub> = 0.8 V, SINK <sub>IN</sub> = 2.0 V	—	<1.0	50	$\mu\text{A}$
		SOURCE <sub>OUT</sub> = 0 V, SOURCE <sub>IN</sub> = 0.8 V, SINK <sub>IN</sub> = 2.0 V	—	<-1.0	-50	$\mu\text{A}$
Output Sustaining Voltage	$V_{CE(sus)}$	$I_{OUT} = \pm 6.0\text{ A}$ , L = 10 mH	40	—	—	V
Output Saturation Voltage	$V_{CE(SAT)}$	SINK <sub>OUT</sub> = 5.0 A	—	—	1.5	V
		SINK <sub>OUT</sub> = 6.0 A	—	—	2.0	V
		SOURCE <sub>OUT</sub> = -5.0 A	—	—	2.0	V
		SOURCE <sub>OUT</sub> = -6.0 A	—	—	2.5	V
Input Voltage	Logic 1	SOURCE <sub>IN</sub> or SINK <sub>IN</sub>	2.0	—	—	V
	Logic 0	SOURCE <sub>IN</sub> or SINK <sub>IN</sub>	—	—	0.8	V
Input Current	Logic 1	SOURCE <sub>IN</sub> or SINK <sub>IN</sub> = 2.0 V	—	3.0	10	$\mu\text{A}$
	Logic 0	SOURCE <sub>IN</sub> or SINK <sub>IN</sub> = 0.8 V	—	-1.0	-10	$\mu\text{A}$
Propagation Delay	$t_{PHL}$	Sink Driver (includes Turn-On Delay)	—	2.5	—	$\mu\text{s}$
		Source Driver	—	2.5	—	$\mu\text{s}$
	$t_{PLH}$	Sink Driver	—	0.2	—	$\mu\text{s}$
		Source Driver (includes Turn-On Delay)	—	2.5	—	$\mu\text{s}$
Supply Current	$I_{S(ON)}$	SOURCE <sub>IN</sub> = 2.0 V	—	10	15	mA
		SOURCE <sub>IN</sub> = SINK <sub>IN</sub> = 0.8 V	—	20	25	mA
	$I_{S(OFF)}$	SOURCE <sub>IN</sub> = 0.8 V, SINK <sub>IN</sub> = 2.0 V	—	8.0	10	mA
Flyback Diode Forward Voltage	$V_F$	$I_F = 6.0\text{ A}$	—	—	2.8	V
Clamp Diode Forward Voltage	$V_F$	$I_F = 6.0\text{ A}$	—	—	2.1	V
Diode Leakage Current	$I_R$	Each Diode, $V_R = 40\text{ V}$	—	<1.0	50	$\mu\text{A}$
Thermal Shutdown	$T_J$		—	165	—	$^\circ\text{C}$

NOTE: Typical Data is given for circuit design information only.  
 Negative current is defined as coming out of (sourcing) the specified device pin.