

Resonator THT, 3 Pin

Features:

- Low cost
- Consumer electronics
- Microprocessor systems
- Excellent for automotive applications

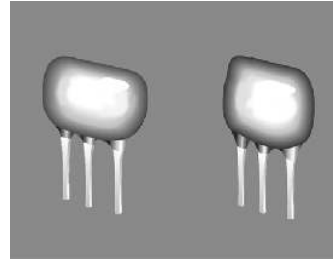

ZTT/MG
ZTT/MT
ZTT/MX

Specifications					
Part	ZTT/MG	ZTT/MT	ZTT/MX	ZTT/MX	ZTT/MX
Frequency range (MHz)	1.80 ~ 6.00	5.00 ~ 13.00	13.01 ~ 20.00	20.01 ~ 25.99	26.00 ~ 50.00
Frequency accuracy (25°C)	+/-0.5%	+/-0.5%	+/-0.5%	+/-0.5%	+/-0.5%
Temperature stability (-20°C ~ +80°C)	+/-0.3%	+/-0.3%	+/-0.3%	+/-0.3%	+/-0.3%
Aging (over 10 years)	+/-0.3%	+/-0.3%	+/-0.3%	+/-0.3%	+/-0.3%
Build-in load capacitance (pF)	C1	30	22	22	5
	C2	30	22	22	15

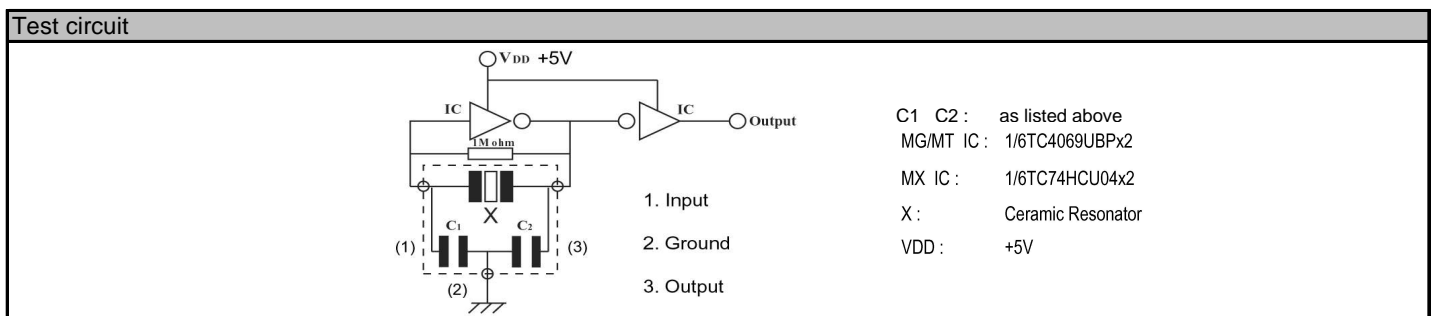
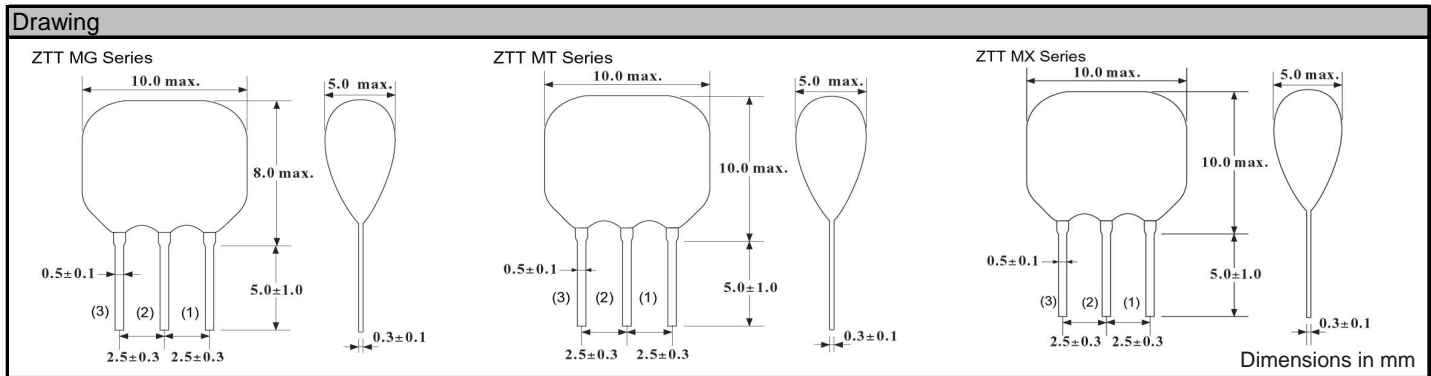

Order key						
R	- 13.000000M	- ZTT/MT	- 0.5	- 0.3	- H	- 22/22
Part	Frequency	Type/Package	Frequency tolerance	Temperature tolerance	Temperature range	Internal load capacitance
R=Resonator	K=KHz M=MHz	ZTT/MG ZTT/MT ZTT/MX	+/-% (25°C)	+/-% (Temp. range)	H=-20°C ~ +80°C	pF C1/C2