

## 256抽头、非易失、I<sup>2</sup>C接口 数字电位器

### 概述

MAX5417/MAX5418/MAX5419是非易失、线性数字电位器，与机械电位器功能相似，但可通过简单的2线数字接口控制，允许多个器件进行通信。每个器件具有分离电位器或可变电阻的功能，具有256个抽头点。

这些器件内置非易失EEPROM，用于存储滑动端的位置，上电时进行初始化处理。快速模式I<sup>2</sup>C™兼容接口允许400kbps的通信速率，在许多应用场合可有效减小电路板面积，简化电路连接。每个器件有一个工厂预置地址，有四种地址选择（见选择指南），配合地址选择输入，共提供八个唯一的地址组合。

MAX5417/MAX5418/MAX5419提供了三个标称阻值：50kΩ (MAX5417)、100kΩ (MAX5418)和200kΩ (MAX5419)。标称电阻的端到端温度系数为35ppm/°C，比率温度系数仅为5ppm/°C，非常适合低温漂可变电阻的应用，如低漂移、可编程增益放大器。

MAX5417/MAX5418/MAX5419采用3mm × 3mm、8引脚TDFN封装，工作在-40°C至+85°C扩展级温度范围。

### 应用

- 替代机械电位器
- 低漂移可编程增益放大器
- 音量控制
- 液晶显示屏 (LCD)对比度控制

### 特性

- ◆ 上电后从非易失存储器调用滑动端位置
- ◆ 微型3mm × 3mm、8引脚TDFN封装
- ◆ 端到端电阻温度系数：35ppm/°C
- ◆ 比率温度系数：5ppm/°C
- ◆ 阻值：50kΩ/100kΩ/200kΩ
- ◆ 快速I<sup>2</sup>C兼容串行接口
- ◆ 500nA (典型值)静态电流
- ◆ 单电源+2.7V至+5.25V供电
- ◆ 256抽头
- ◆ 分压模式下DNL为：±0.5 LSB
- ◆ 分压模式下INL为：±0.5 LSB

### 功能图

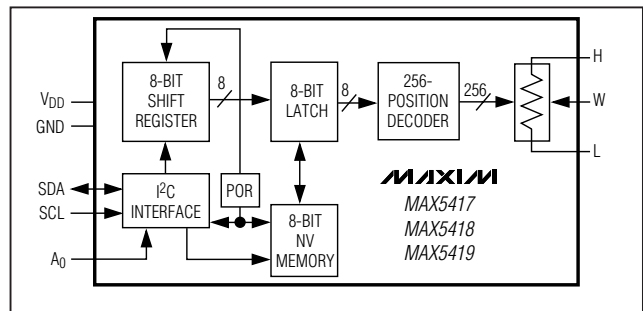

I<sup>2</sup>C是 Philips Corp.的一个商标。

购买 Maxim Integrated Products, Inc. 或其从属授权公司的 I<sup>2</sup>C 产品，即得到了 Philips I<sup>2</sup>C 的专利许可、将这些产品用于符合 Philips 定义的 I<sup>2</sup>C 标准规范的系统。

### 订购信息/选择指南

PART	TEMP RANGE	I <sup>2</sup> C ADDRESS	R (kΩ)	PIN-PACKAGE	TOP MARK
MAX5417LETA	-40°C to +85°C	010100A <sub>0</sub>	50	8 TDFN-EP**	AIB
MAX5417META*	-40°C to +85°C	010101A <sub>0</sub>	50	8 TDFN-EP**	ALS
MAX5417NETA*	-40°C to +85°C	010110A <sub>0</sub>	50	8 TDFN-EP**	ALT
MAX5417PETA*	-40°C to +85°C	010111A <sub>0</sub>	50	8 TDFN-EP**	ALU
MAX5418LETA	-40°C to +85°C	010100A <sub>0</sub>	100	8 TDFN-EP**	AIC
MAX5418META*	-40°C to +85°C	010101A <sub>0</sub>	100	8 TDFN-EP**	ALV
MAX5418NETA*	-40°C to +85°C	010110A <sub>0</sub>	100	8 TDFN-EP**	ALW
MAX5418PETA*	-40°C to +85°C	010111A <sub>0</sub>	100	8 TDFN-EP**	ALX
MAX5419LETA	-40°C to +85°C	010100A <sub>0</sub>	200	8 TDFN-EP**	AID
MAX5419META*	-40°C to +85°C	010101A <sub>0</sub>	200	8 TDFN-EP**	ALY
MAX5419NETA*	-40°C to +85°C	010110A <sub>0</sub>	200	8 TDFN-EP**	ALZ
MAX5419PETA*	-40°C to +85°C	010111A <sub>0</sub>	200	8 TDFN-EP**	AMA

\*Future product—contact factory for availability.

\*\*Exposed pad.

引脚配置见本文的最后部分。

# 256抽头、非易失、I<sup>2</sup>C接口 数字电位器

## ABSOLUTE MAXIMUM RATINGS

V <sub>DD</sub> to GND	-0.3V to +6.0V
All Other Pins to GND	-0.3V to (V <sub>DD</sub> + 0.3V)
Maximum Continuous Current into H, L, and W	
MAX5417	±1.3mA
MAX5418	±0.6mA
MAX5419	±0.3mA

Continuous Power Dissipation (T <sub>A</sub> = +70°C)	
8-Pin TDFN (derate 24.4mW/°C above +70°C)	1951mW
Operating Temperature Range	-40°C to +85°C
Junction Temperature	+150°C
Storage Temperature Range	-60°C to +150°C
Lead Temperature (soldering, 10s)	+300°C

Stresses beyond those listed under "Absolute Maximum Ratings" may cause permanent damage to the device. These are stress ratings only, and functional operation of the device at these or any other conditions beyond those indicated in the operational sections of the specifications is not implied. Exposure to absolute maximum rating conditions for extended periods may affect device reliability.

## ELECTRICAL CHARACTERISTICS

(V<sub>DD</sub> = +2.7V to +5.25V, H = V<sub>DD</sub>, L = GND, T<sub>A</sub> = -40°C to +85°C, unless otherwise noted. Typical values are at V<sub>DD</sub> = +5V, T<sub>A</sub> = +25°C.)

PARAMETER	SYMBOL	CONDITIONS	MIN	TYP	MAX	UNITS
<b>DC PERFORMANCE (VOLTAGE-DIVIDER MODE)</b>						
Resolution			256			Taps
Integral Nonlinearity	INL	(Note 1)			±0.5	LSB
Differential Nonlinearity	DNL	(Note 1)			±0.5	LSB
End-to-End Temperature Coefficient	TC <sub>R</sub>			35		ppm/°C
Ratiometric Temperature Coefficient				5		ppm/°C
Full-Scale Error		MAX5417_, 50Ω		-0.6		LSB
		MAX5418_, 100kΩ		-0.3		
		MAX5419_, 200kΩ		-0.15		
Zero-Scale Error		MAX5417_, 50kΩ		0.6		LSB
		MAX5418_, 100kΩ		0.3		
		MAX5419_, 200kΩ		0.15		
<b>DC PERFORMANCE (VARIABLE-RESISTOR MODE)</b>						
Integral Nonlinearity (Note 2)	INL	V <sub>DD</sub> = 3V			±3	LSB
		V <sub>DD</sub> = 5V			±1.5	
Differential Nonlinearity (Note 2)	DNL	V <sub>DD</sub> = 3V, MAX5417_, 50kΩ, guaranteed monotonic	-1		+2	LSB
		V <sub>DD</sub> = 3V, MAX5418_, 100kΩ			±1	
		MAX5419_, 200kΩ			±1	
		V <sub>DD</sub> = 5V			±1	
<b>DC PERFORMANCE (RESISTOR CHARACTERISTICS)</b>						
Wiper Resistance	R <sub>W</sub>	V <sub>DD</sub> = 3V to 5.25V (Note 3)		325	675	Ω
Wiper Capacitance	C <sub>W</sub>			10		pF
End-to-End Resistance	R <sub>HL</sub>	MAX5417_	37.5	50	62.5	kΩ
		MAX5418_	75	100	125	
		MAX5419_	150	200	250	

# 256抽头、非易失、I<sup>2</sup>C接口 数字电位器

MAX5417/MAX5418/MAX5419

## ELECTRICAL CHARACTERISTICS (continued)

(V<sub>DD</sub> = +2.7V to +5.25V, H = V<sub>DD</sub>, L = GND, T<sub>A</sub> = -40°C to +85°C, unless otherwise noted. Typical values are at V<sub>DD</sub> = +5V, T<sub>A</sub> = +25°C.)

PARAMETER	SYMBOL	CONDITIONS	MIN	TYP	MAX	UNITS
<b>DIGITAL INPUTS</b>						
Input High Voltage (Note 4)	V <sub>IH</sub>	V <sub>DD</sub> = 3.4V to 5.25V	2.4			V
		V <sub>DD</sub> < 3.4V	0.7 x V <sub>DD</sub>			
Input Low Voltage	V <sub>IL</sub>	V <sub>DD</sub> = 2.7V to 5.25V (Note 4)			0.8	V
Low-Level Output Voltage	V <sub>OL</sub>	3mA sink current			0.4	V
Input Leakage Current	I <sub>LEAK</sub>				±1	μA
Input Capacitance			5			pF
<b>DYNAMIC CHARACTERISTICS</b>						
Wiper -3dB Bandwidth (Note 5)		MAX5417_	100			kHz
		MAX5418_	50			
		MAX5419_	25			
<b>NONVOLATILE MEMORY</b>						
Data Retention		T <sub>A</sub> = +85°C	50			Years
Endurance		T <sub>A</sub> = +25°C	200,000			Stores
		T <sub>A</sub> = +85°C	50,000			
<b>POWER SUPPLY</b>						
Power-Supply Voltage	V <sub>DD</sub>		2.70		5.25	V
Standby Current	I <sub>DD</sub>	Digital inputs = V <sub>DD</sub> or GND, T <sub>A</sub> = +25°C		0.5	1	μA
Programming Current		During nonvolatile write; digital inputs = V <sub>DD</sub> or GND (Note 6)		200	400	μA

## TIMING CHARACTERISTICS

(V<sub>DD</sub> = +2.7V to +5.25V, H = V<sub>DD</sub>, L = GND, T<sub>A</sub> = -40°C to +85°C, unless otherwise noted. Typical values are at V<sub>DD</sub> = +5V, T<sub>A</sub> = +25°C. See Figures 1 and 2.) (Note 7)

PARAMETER	SYMBOL	CONDITIONS	MIN	TYP	MAX	UNITS
<b>ANALOG SECTION</b>						
Wiper Settling Time (Note 8)	t <sub>IL</sub>	MAX5417_	500			ns
		MAX5418_	600			
		MAX5419_	1000			
<b>DIGITAL SECTION</b>						
SCL Clock Frequency	f <sub>SCL</sub>				400	kHz
Setup Time for START Condition	t <sub>SU-STA</sub>		0.6			μs
Hold Time for START Condition	t <sub>HD-STA</sub>		0.6			μs
CLK High Time	t <sub>HIGH</sub>		0.6			μs
CLK Low Time	t <sub>LOW</sub>		1.3			μs

## 256抽头、非易失、I<sup>2</sup>C接口 数字电位器

### TIMING CHARACTERISTICS (continued)

(V<sub>DD</sub> = +2.7V to +5.25V, H = V<sub>DD</sub>, L = GND, T<sub>A</sub> = -40°C to +85°C, unless otherwise noted. Typical values are at V<sub>DD</sub> = +5V, T<sub>A</sub> = +25°C. See Figures 1 and 2.) (Note 7)

PARAMETER	SYMBOL	CONDITIONS	MIN	TYP	MAX	UNITS
Data Setup Time	t <sub>SU-DAT</sub>		100			ns
Data Hold Time	t <sub>HD-DAT</sub>		0		0.9	μs
SDA, SCL Rise Time	t <sub>R</sub>				300	ns
SDA, SCL Fall Time	t <sub>F</sub>				300	ns
Setup Time for STOP Condition	t <sub>SU-STO</sub>		0.6			μs
Bus Free Time Between STOP and START Condition	t <sub>BUF</sub>	Minimum power-up rate = 0.2V/ms	1.3			μs
Pulse Width of Spike Suppressed	t <sub>SP</sub>				50	ns
Maximum Capacitive Load for Each Bus Line	C <sub>B</sub>	(Note 9)		400		pF
Write NV Register Busy Time	t <sub>BUSY</sub>	(Note 10)			12	ms

- Note 1:** The DNL and INL are measured with the potentiometer configured as a voltage-divider with H = V<sub>DD</sub> and L = GND. The wiper terminal is unloaded and measured with a high-input-impedance voltmeter.
- Note 2:** The DNL and INL are measured with the potentiometer configured as a variable resistor. H is unconnected and L = GND. For the 5V condition, the wiper terminal is driven with a source current of 80μA for the 50kΩ configuration, 40μA for the 100kΩ configuration, and 20μA for the 200kΩ configuration. For the 3V condition, the wiper terminal is driven with a source current of 40μA for the 50kΩ configuration, 20μA for the 100kΩ configuration, and 10μA for the 200kΩ configuration.
- Note 3:** The wiper resistance is measured using the source currents given in Note 2. For operation to V<sub>DD</sub> = 2.7V, see Wiper Resistance vs. Temperature in the *Typical Operating Characteristics*.
- Note 4:** The device draws higher supply current when the digital inputs are driven with voltages between (V<sub>DD</sub> - 0.5V) and (GND + 0.5V). See Supply Current vs. Digital Input Voltage in the *Typical Operating Characteristics*.
- Note 5:** Wiper at midscale with a 10pF load (DC measurement). L = GND; an AC source is applied to H; and the W output is measured. A 3dB bandwidth occurs when the AC W/H value is 3dB lower than the DC W/H value.
- Note 6:** The programming current operates only during power-up and NV writes.
- Note 7:** SCL clock period includes rise and fall times t<sub>R</sub> and t<sub>F</sub>. All digital input signals are specified with t<sub>R</sub> = t<sub>F</sub> = 2ns and timed from a voltage level of (V<sub>IL</sub> + V<sub>IH</sub>) / 2.
- Note 8:** Wiper settling time is the worst-case 0% to 50% rise time measured between consecutive wiper positions. H = V<sub>DD</sub>, L = GND, and the wiper terminal is unloaded and measured with a 10pF oscilloscope probe (see the *Typical Operating Characteristics* for the tap-to-tap switching transient).
- Note 9:** An appropriate bus pullup resistance must be selected depending on board capacitance. Refer to the document linked to this web address: [www.semiconductors.philips.com/acrobat/literature/9398/39340011.pdf](http://www.semiconductors.philips.com/acrobat/literature/9398/39340011.pdf).
- Note 10:** The idle time begins from the initiation of the stop pulse.

# 256抽头、非易失、I<sup>2</sup>C接口 数字电位器

典型工作特性

(V<sub>DD</sub> = +5V, T<sub>A</sub> = +25°C, unless otherwise noted.)

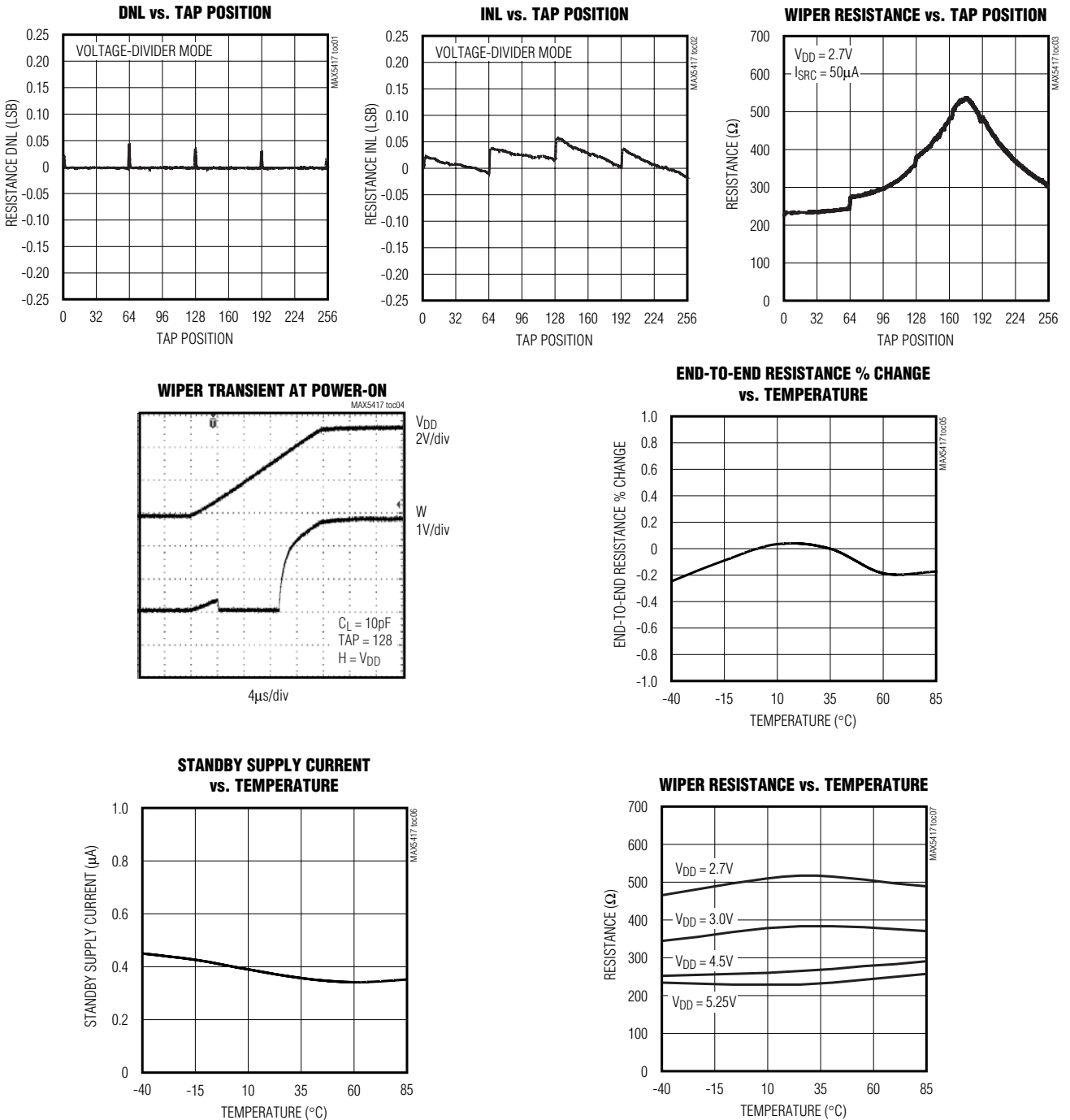

MAX5417/MAX5418/MAX5419

# 256抽头、非易失、I<sup>2</sup>C接口 数字电位器

典型工作特性 (续)

(V<sub>DD</sub> = +5V, T<sub>A</sub> = +25°C, unless otherwise noted.)

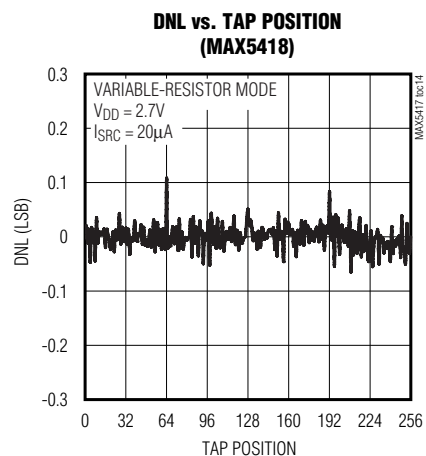
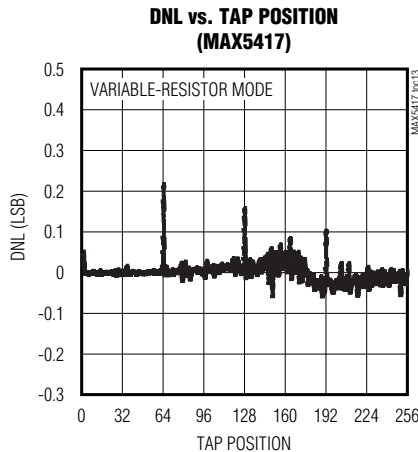
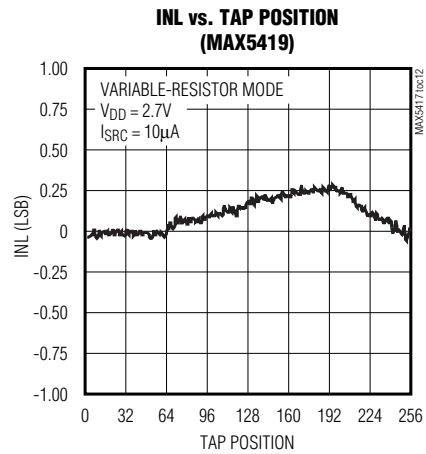
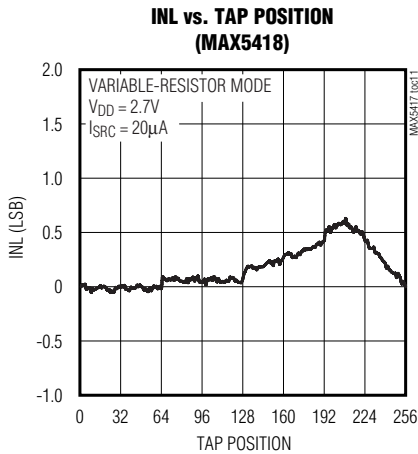
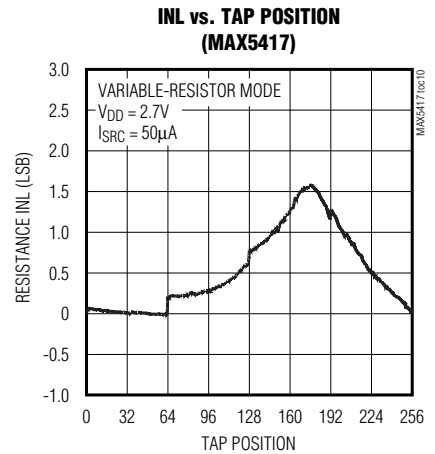
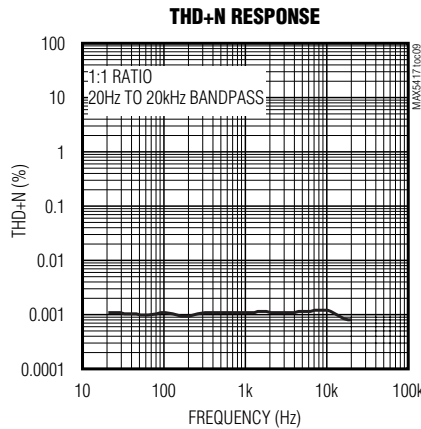
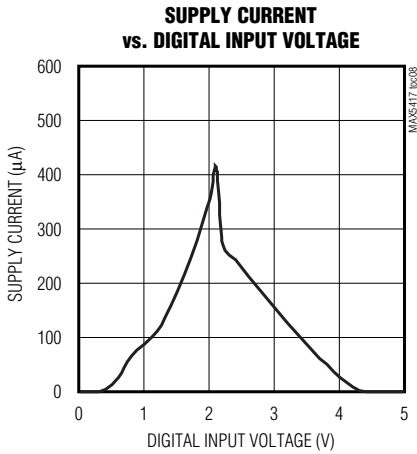

# 256抽头、非易失、I<sup>2</sup>C接口 数字电位器

典型工作特性 (续)

(V<sub>DD</sub> = +5V, T<sub>A</sub> = +25°C, unless otherwise noted.)

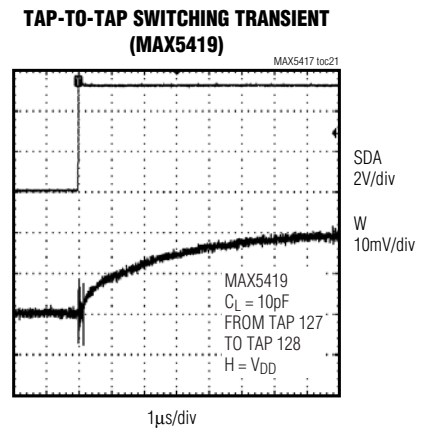
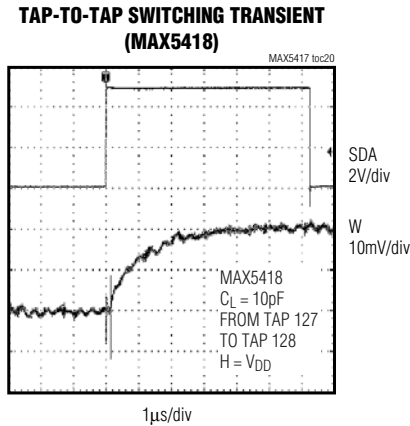
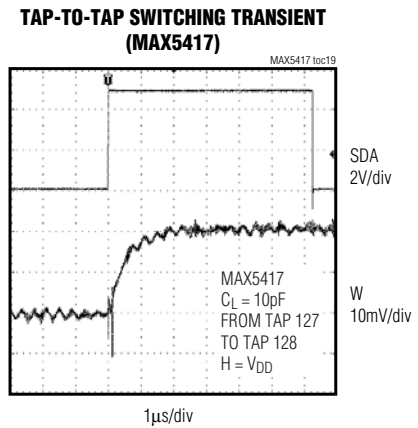
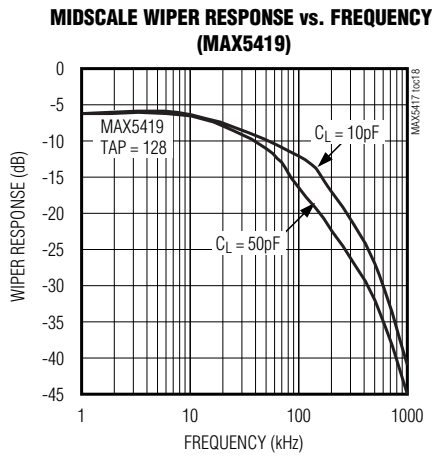
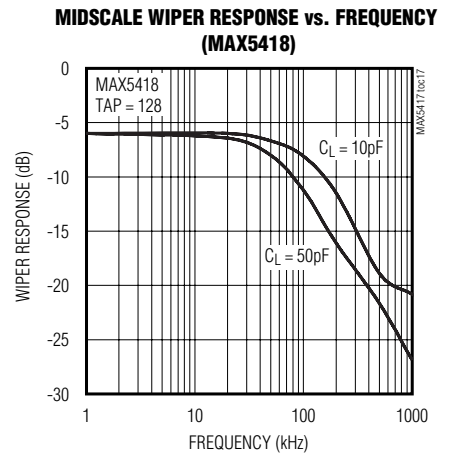
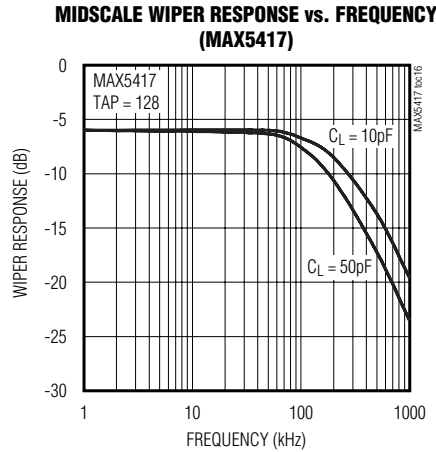
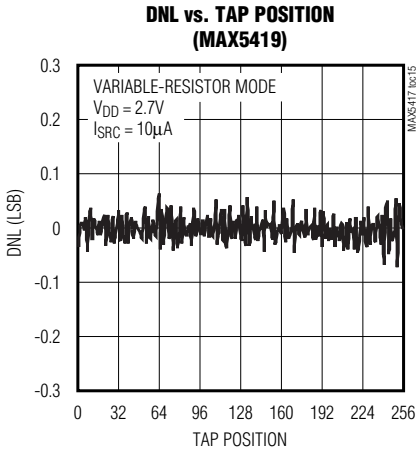

# 256抽头、非易失、I<sup>2</sup>C接口 数字电位器

引脚说明

引脚	名称	功能
1	V <sub>DD</sub>	电源输入，电压范围：2.7V至5.25V。用0.1μF电容旁路V <sub>DD</sub> 至GND。
2	SCL	I <sup>2</sup> C接口时钟输入
3	SDA	I <sup>2</sup> C接口数据输入
4	A0	地址输入端，设置器件ID的A0位。
5	GND	地
6	L	低端
7	W	滑动端
8	H	高端
—	EP	裸露焊盘

图 1. I<sup>2</sup>C 串行接口时序

图 2. 负载电路

详细说明

MAX5417/MAX5418/MAX5419内置电阻阵列，包含 256 个电阻单元。MAX5417端到端阻值为 50kΩ，MAX5418端到端阻值为 100kΩ，MAX5417端到端阻值为 200kΩ。MAX5417/MAX5418/MAX5419通过连接高端、低端和滑动端可以构成标准的分压器，H、L和W端可以任意配置，只需保证各端电压在GND和V<sub>DD</sub>之间。

简单的 2线 I<sup>2</sup>C兼容串行接口可以在 256个触点间调节滑动端。非易失存储器储存并在上电时恢复滑动端的位置。非易失存储器确保 200,000次抽头读写，寄存器数据可保持 50年。

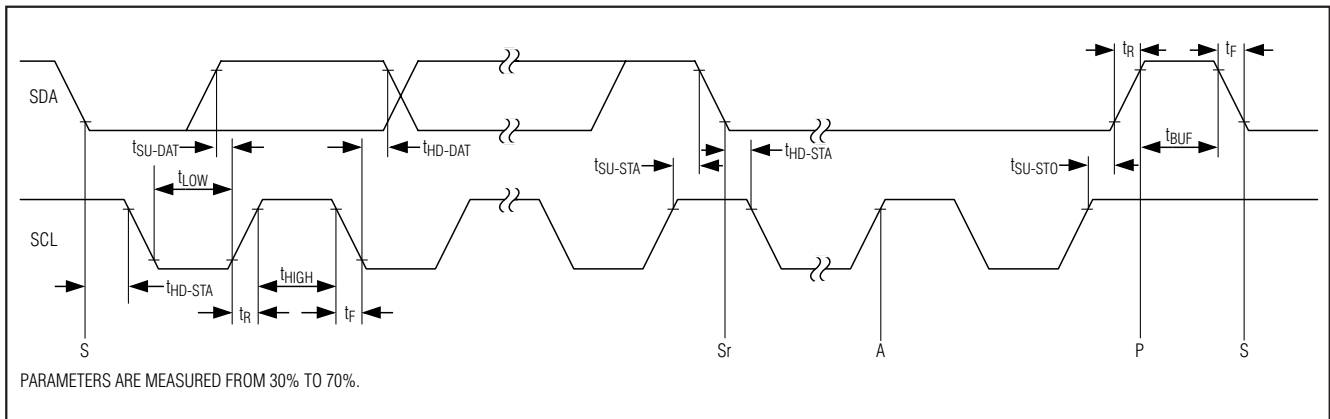
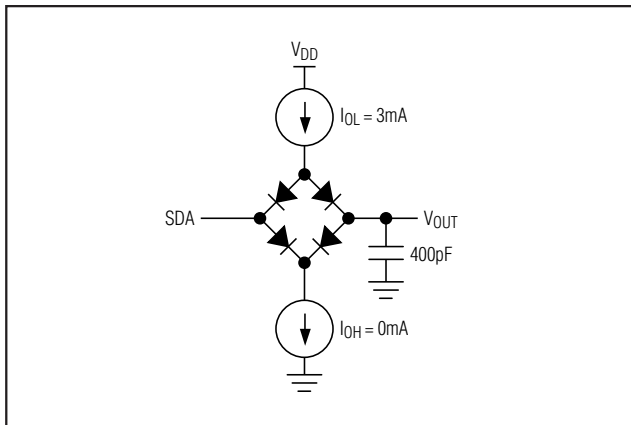

## 256抽头、非易失、I<sup>2</sup>C接口 数字电位器

### 模拟电路

MAX5417/MAX5418/MAX5419内置一个电阻阵列，包含255个电阻单元；256个抽头点可以沿着H、L之间的电阻串接至滑动端(W)。滑动端的位置选择通过2线(I<sup>2</sup>C)接口对数字电位器编程实现。8位数据，一个地址字节，和一个控制字节设置抽头位置。MAX5417/MAX5418/MAX5419的H、L端与机械电位器的两个端点相同。MAX5417/MAX5418/MAX5419带有上电复位电路，在上电时从非易失存储器自动装载滑动端的位置。

### 数字接口

MAX5417/MAX5418/MAX5419内置非易失EEPROM，用于存储滑动端的位置，以便上电时的初始化处理。移位寄存器对控制位和地址位进行解码，将数据写入适当的数据寄存器。数据可以写入易失存储寄存器，立即更新滑动端的位置，也可以写入非易失寄存器存储。

易失寄存器在系统加电期间能够保持数据。一旦系统断电，易失寄存器的内容被清除。非易失寄存器在系统断电时仍能保存数据。一旦上电，上电复位电路将非易失存储器的内容自动传送到易失寄存器中，更新滑动端的位置。



图3. 启动条件和停止条件



图4. 从地址

### 串行寻址

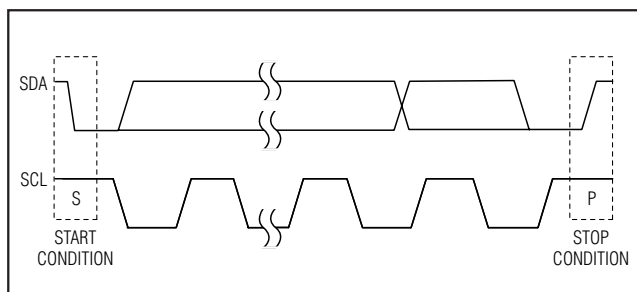
MAX5417/MAX5418/MAX5419作为从设备从I<sup>2</sup>C或SMBus™兼容的2线接口接收数据，该接口采用串行数据线(SDA)和串行时钟线(SCL)实现主、从设备之间的通信。主设备通常是微控制器，启动MAX5417/MAX5418/MAX5419的全部数据传输，并产生SCL时钟，同步数据传输(见图1)。

MAX5417/MAX5418/MAX5419的SDA可作为输入或漏极开路输出，SDA线上需要一个典型值为4.7kΩ的上拉电阻。MAX5417/MAX5418/MAX5419的SCL只能作为输入端。若2线接口挂接有多个主机，或者是具有SCL漏极开路输出的单主机系统，SCL线上需接典型值为4.7kΩ的上拉电阻。

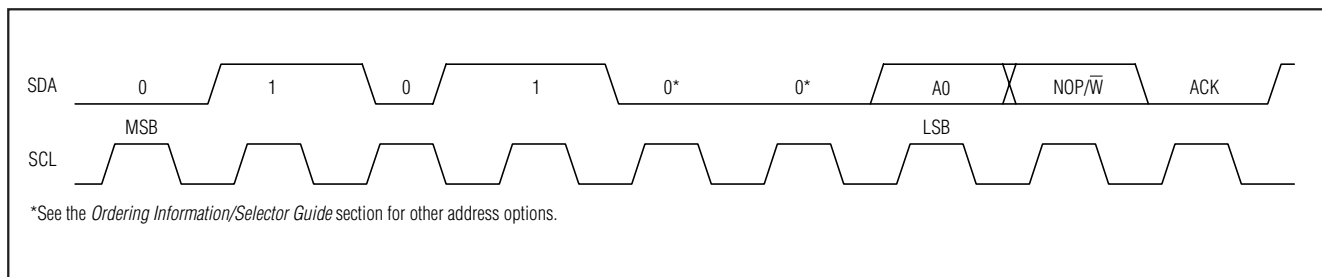
每次数据传输先由主机发送启动(START)条件(S)(图3)，然后发送MAX5417/MAX5418/MAX5419的7位从地址和第8位(图4)，1个命令字节(图7)和1个数据字节，最后是停止(STOP)条件(P)(图3)。

### 启动条件和停止条件

接口不工作时SCL和SDA均为高。主机发送启动条件开始数据传输，即SCL为高电平时SDA出现由高至低的下降沿。当主机完成与从机的通信后发送停止条件，即在SCL为高电平时SDA出现由低至高的上升沿。然后释放总线，进行另外的传输(图3)。

### 位传输

每个时钟传输一个数据位。SCL为高时，SDA上的数据必需保持稳定(图5)。

SMBus是Intel Corporation的一个商标。

## 256抽头、非易失、I<sup>2</sup>C接口 数字电位器

表 1. MAX5417/MAX5418/MAX5419的地址码

ADDRESS BYTE								
PART SUFFIX	A6	A5	A4	A3	A2	A1	A0	NOP/ $\overline{W}$
L	0	1	0	1	0	0	0	NOP/ $\overline{W}$
L	0	1	0	1	0	0	1	NOP/ $\overline{W}$
M	0	1	0	1	0	1	0	NOP/ $\overline{W}$
M	0	1	0	1	0	1	1	NOP/ $\overline{W}$
N	0	1	0	1	1	0	0	NOP/ $\overline{W}$
N	0	1	0	1	1	0	1	NOP/ $\overline{W}$
P	0	1	0	1	1	1	0	NOP/ $\overline{W}$
P	0	1	0	1	1	1	1	NOP/ $\overline{W}$

### 应答信号

应答位是第 9 个时钟位，它是收到每个数据字节的应答握手信号 (图 6)。因此，每个字节的有效传输需要 9 位。主机产生第 9 个时钟脉冲，接收端在应答时钟周期内将 SDA 拉低，所以在时钟为高电平期间 SDA 必须稳定在低电平。当主机向 MAX5417/MAX5418/MAX5419 传输数据时，MAX5417/MAX5418/MAX5419 产生应答信号，因为它们都是数据的接收者。

### 从地址

MAX5417/MAX5418/MAX5419 具有 7 位从地址 (图 4)。紧随 7 位从地址的第 8 位是 NOP/ $\overline{W}$  位，NOP/ $\overline{W}$  位置低表示写操作，置高表示空操作。

MAX5417/MAX5418/MAX5419 提供四种从地址 (表 1)。MAX5417/MAX5418/MAX5419 的高 4 位地址始终为 0101，接下来的 2 位由工厂设置 (见表 1)。将 A0 输入接 GND 或 V<sub>DD</sub>，可以在两个唯一地址中为器件选择做出选择。只有具有唯一地址的器件才能共享总线。因此，最多可以有 8 个 MAX5417/MAX5418/MAX5419 挂接在同一总线上。



图 5. 位传输



图 6. 应答信号

# 256抽头、非易失、I<sup>2</sup>C接口 数字电位器

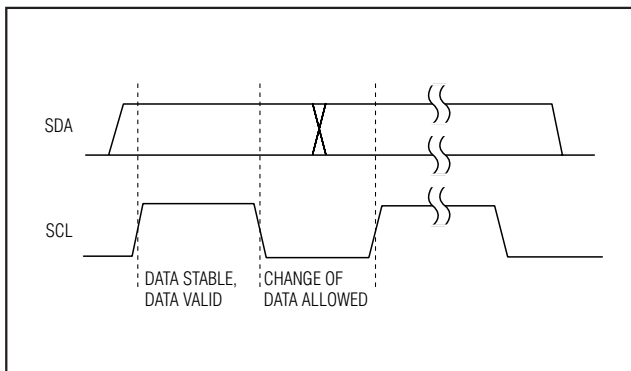

图 7. 接收到的命令字节

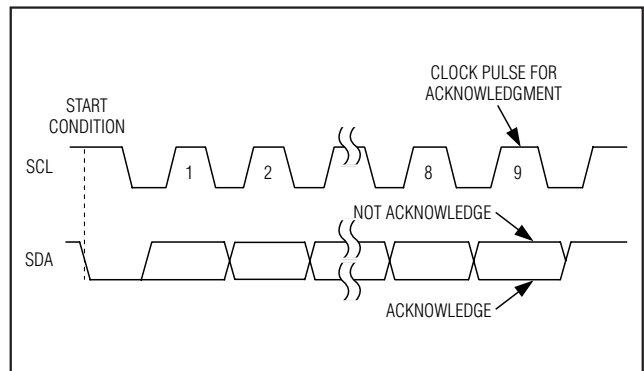

图 8. 接收到的命令和单个数据字节

## 写数据格式

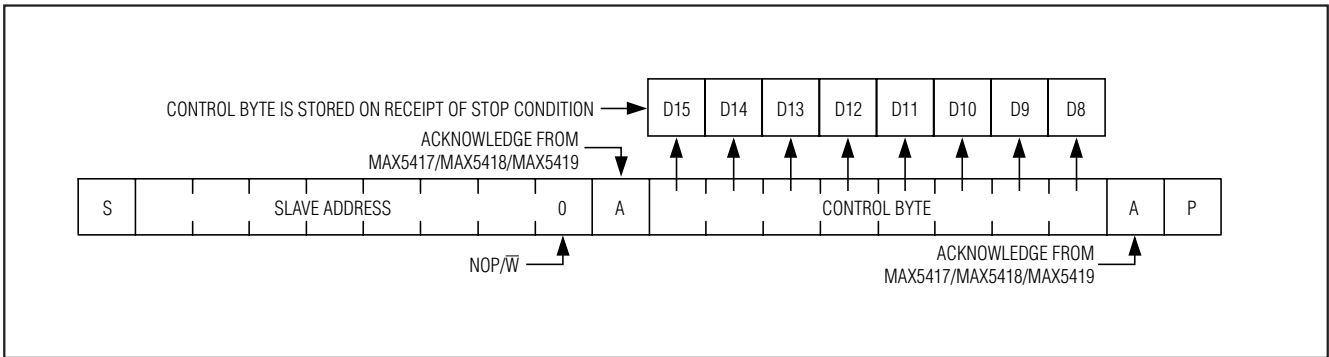
向 MAX5417/MAX5418/MAX5419 写入数据时，传输内容包括器件从地址字节 (第 8 位置零) 和至少一个字节的的信息 (图 7)。第 1 个信息字节为命令字节，命令字节之后是数据字节。第一个数据字节按照命令字节的选择写入内部寄存器 (图 8)。

## 命令字节

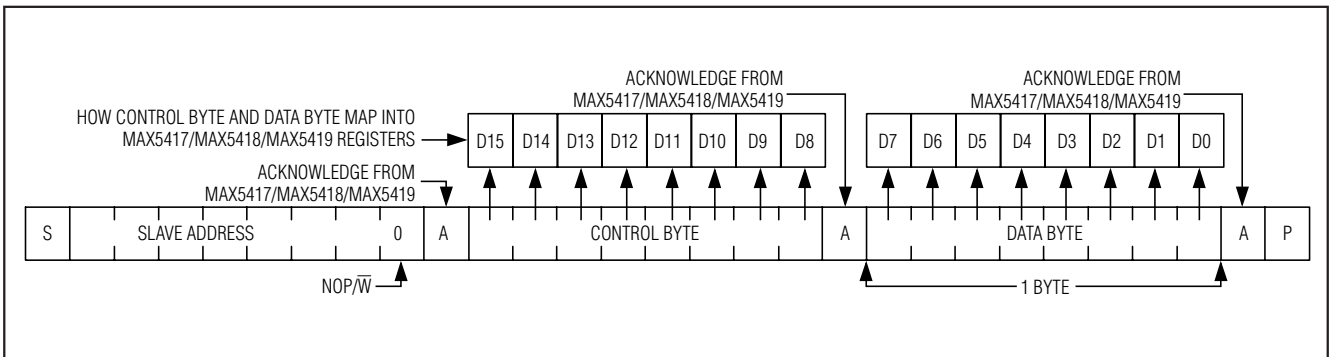
命令字节用于选择滑动端数据的源地址和目的地址 (非易失或易失存储寄存器)，或在非易失或易失存储寄存器之间交换数据 (见表 2)。

## 命令说明

**VREG:** 数据字节写入易失存储寄存器，滑动端位置更新为易失存储寄存器中的数据。

**NVREG:** 数据字节写入非易失存储寄存器，滑动端位置保持不变。

**NVREGxVREG:** 数据从非易失存储寄存器传送到易失寄存器 (滑动端位置更新)。

**VREGxNVREG:** 数据从易失寄存器传送到非易失存储寄存器。

# 256抽头、非易失、I<sup>2</sup>C接口 数字电位器

表 2. 命令字节

SCL CYCLE NUMBER	S	ADDRESS BYTE								CONTROL BYTE								DATA BYTE								P			
		1	2	3	4	5	6	7	8	9	10	11	12	13	14	15	16	17	18	19	20	21	22	23	24		25	26	27
		A6	A5	A4	A3	A2	A1	A0	ACK		TX	NV	V	R3	R2	R1	R0	ACK	D7	D6	D5	D4	D3	D2	D1	D0	ACK		
VREG		0	1	0	1	A2	A1	A0	0		0	0	0	1	0	0	0	1		D7	D6	D5	D4	D3	D2	D1	D0		
NVREG		0	1	0	1	A2	A1	A0	0		0	0	1	0	0	0	0	1		D7	D6	D5	D4	D3	D2	D1	D0		
NVREGxVREG		0	1	0	1	A2	A1	A0	0		0	1	1	0	0	0	0	1		D7	D6	D5	D4	D3	D2	D1	D0		
VREGxNVREG		0	1	0	1	A2	A1	A0	0		0	1	0	1	0	0	0	1		D7	D6	D5	D4	D3	D2	D1	D0		

### 非易失存储器

内置 EEPROM 包含一个 8 位非易失寄存器，保留断电前写入的数据。非易失寄存器在工厂预置为零值。

### 上电

上电时，MAX5417/MAX5418/MAX5419 将存储在非易失寄存器的数据装入易失寄存器内，并随之更新抽头位置。初始化过程需要 10μs。

### 待机

MAX5417/MAX5418/MAX5419 具有低功耗待机模式。器件没有编程时，进入待机模式，电流消耗典型值为 500nA。

### 应用信息

MAX5417/MAX5418/MAX5419 用于需要数控调节电阻的系统，如 LCD 对比度调节 (利用偏置电压调节显示器对比度)，可调增益和/或截止频率的可编程滤波器等。

### LCD 正偏置控制

图 9 和图 10 显示了用分压器或可变电阻调节 LCD 正向偏置电压的应用电路图。运放提供电阻分压电路的缓冲和放大，电阻分压电路可以由电位器构成 (图 9)，或由一个固定电阻串联一个可变电阻构成 (图 10)。

### 可编程滤波器

图 11 为一阶可编程滤波器电路。滤波器的增益由 R2 调节，截止频率通过 R3 调节。利用下式计算增益 (G) 和 3dB 截止频率 (f<sub>c</sub>):

$$G = 1 + \frac{R1}{R2}$$

$$f_c = \frac{1}{2\pi \times R3 \times C}$$



图 9. 用分压器实现 LCD 正偏调节



图 10. 用可变电阻实现 LCD 正偏调节

## 256抽头、非易失、I<sup>2</sup>C接口 数字电位器

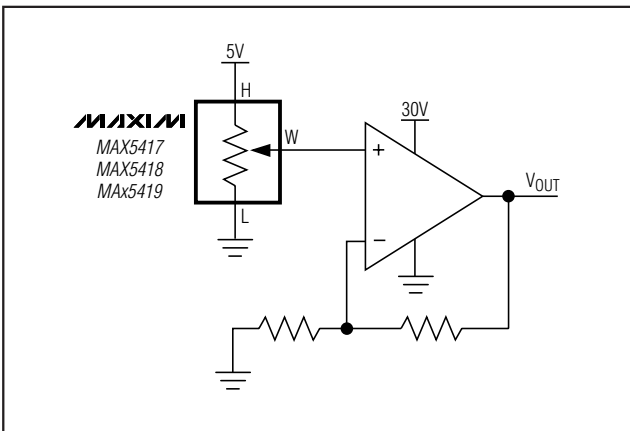

图 11. 可编程滤波器

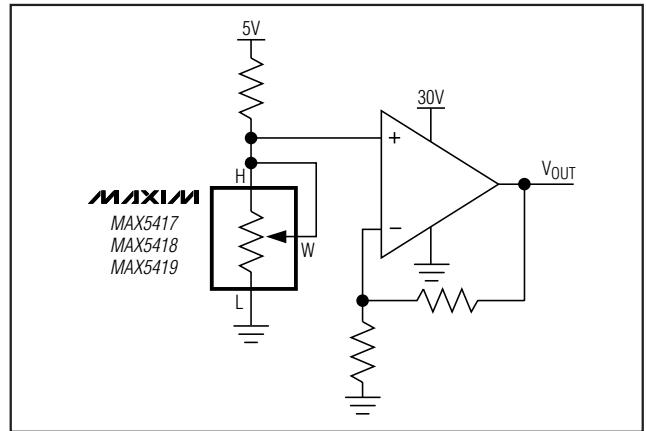

图 13. 失调电压与增益调节电路

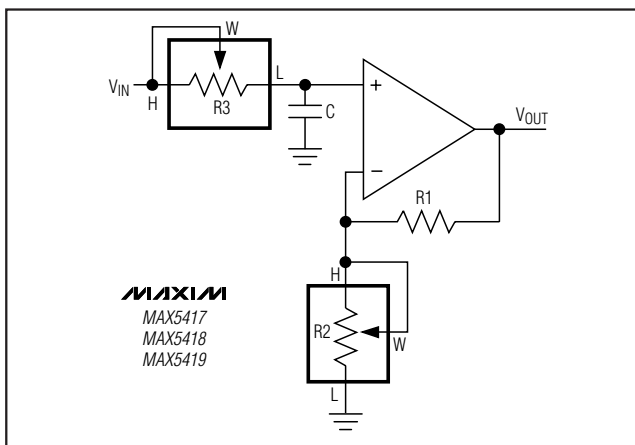

图 12. 可调电压基准

### 可调电压基准

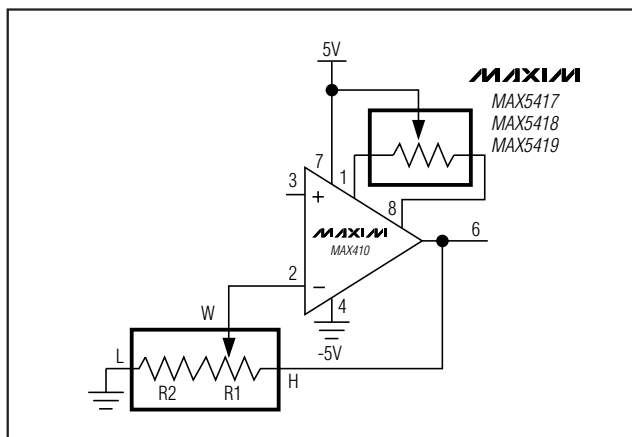
图 12 所示为使用 MAX5417/MAX5418/MAX5419 作为多级可调电压基准应用中的反馈电阻。通过改变 MAX5417/MAX5418/MAX5419 滑动端的位置，可在从 1.23V 至  $V_{IN} - 0.2V$  的范围内独立调节 MAX6160 的输出电压。

### 引脚配置

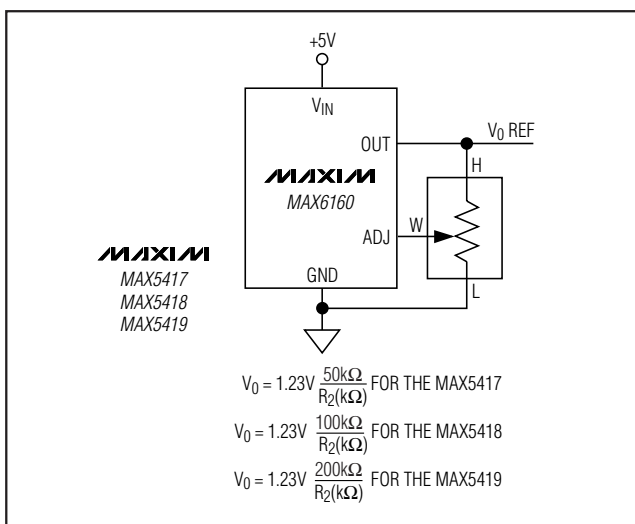
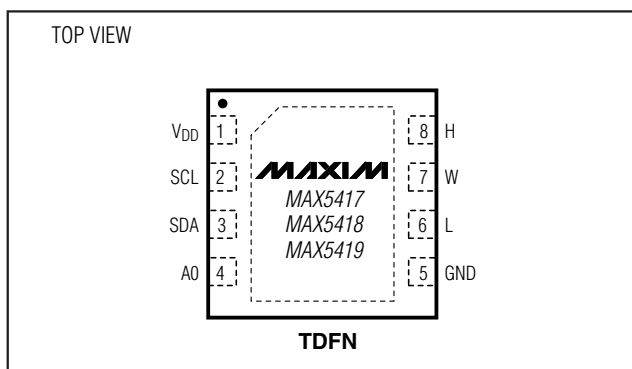

### 失调电压和增益调节

将 MAX5417 中一个电位器的高端和低端分别接 MAX410 的 NULL 输入，滑动端接运放的正电源，可在整个工作温度范围内调节失调电压。另一个电位器用在 MAX410 的反馈回路上以调节其增益。

### 芯片信息

TRANSISTOR COUNT: 4637

PROCESS: BiCMOS

# 256抽头、非易失、I<sup>2</sup>C接口 数字电位器

封装信息

(本数据资料提供的封装图可能不是最近的规格，如需最近的封装外型信息，请查询 [www.maxim-ic.com.cn/packages](http://www.maxim-ic.com.cn/packages)。)

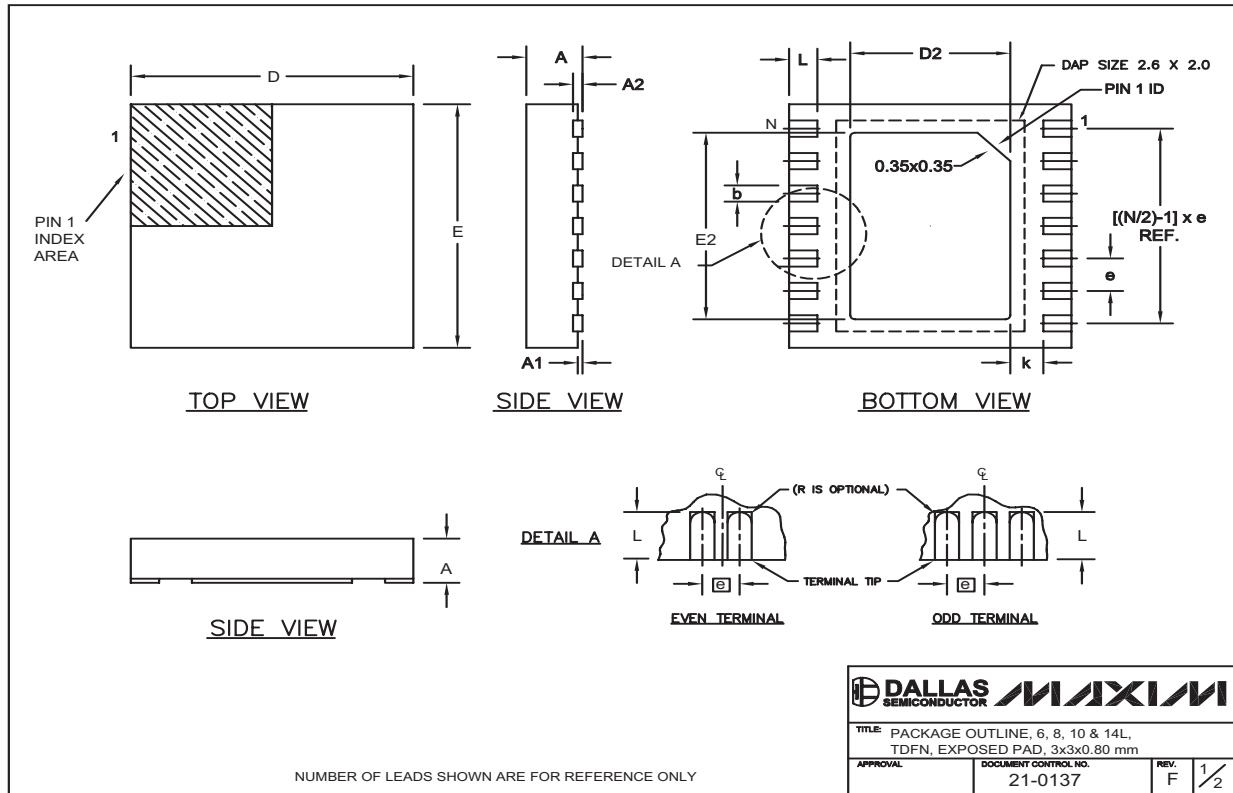

# 256抽头、非易失、I<sup>2</sup>C接口 数字电位器

封装信息 (续)

(本数据资料提供的封装图可能不是最近的规格, 如需最近的封装外型信息, 请查询 [www.maxim-ic.com.cn/packages](http://www.maxim-ic.com.cn/packages)。)

MAX5417/MAX5418/MAX5419

COMMON DIMENSIONS		
SYMBOL	MIN.	MAX.
A	0.70	0.80
D	2.90	3.10
E	2.90	3.10
A1	0.00	0.05
L	0.20	0.40
k	0.25 MIN.	
A2	0.20 REF.	

PACKAGE VARIATIONS							
PKG. CODE	N	D2	E2	e	JEDEC SPEC	b	[(N/2)-1] x e
T633-1	6	1.50±0.10	2.30±0.10	0.95 BSC	MO229 / WEEA	0.40±0.05	1.90 REF
T833-1	8	1.50±0.10	2.30±0.10	0.65 BSC	MO229 / WEEC	0.30±0.05	1.95 REF
T1033-1	10	1.50±0.10	2.30±0.10	0.50 BSC	MO229 / WEED-3	0.25±0.05	2.00 REF
T1433-1	14	1.70±0.10	2.30±0.10	0.40 BSC	----	0.20±0.03	2.40 REF
T1433-2	14	1.70±0.10	2.30±0.10	0.40 BSC	----	0.20±0.03	2.40 REF

**NOTES:**

1. ALL DIMENSIONS ARE IN mm. ANGLES IN DEGREES.
2. COPLANARITY SHALL NOT EXCEED 0.08 mm.
3. WARPAGE SHALL NOT EXCEED 0.10 mm.
4. PACKAGE LENGTH/PACKAGE WIDTH ARE CONSIDERED AS SPECIAL CHARACTERISTIC(S).
5. DRAWING CONFORMS TO JEDEC MO229, EXCEPT DIMENSIONS "D2" AND "E2", AND T1433-1 & T1433-2.
6. "N" IS THE TOTAL NUMBER OF LEADS.

			
TITLE: PACKAGE OUTLINE, 6, 8, 10 & 14L, TDFN, EXPOSED PAD, 3x3x0.80 mm			
APPROVAL	DOCUMENT CONTROL NO.	REV.	
	21-0137	F	2/2

## MAXIM北京办事处

北京 8328信箱 邮政编码 100083

免费电话: 800 810 0310

电话: 010-6201 0598

传真: 010-6201 0298

Maxim 不对 Maxim 产品以外的任何电路使用负责, 也不提供其专利许可。Maxim 保留在任何时间、没有任何通报的前提下修改产品资料和规格的权利。

Maxim Integrated Products, 120 San Gabriel Drive, Sunnyvale, CA 94086 408-737-7600 \_\_\_\_\_ 15